



# A New Approach on Improving The Operation of Over-Current Relays in 6kV Mining Grids of QuangNinh, VietNam

BUN Ho Viet<sup>1)</sup>, THANH Le Xuan<sup>2)</sup>

<sup>1)</sup> Department of Electrification; HaNoi University of Mining and Geology, HaNoi, VietNam

<sup>2)</sup> Department of Electrification; HaNoi University of Mining and Geology, HaNoi, VietNam; email: lexuanthanh@humg.edu.vn

<http://doi.org/10.29227/IM-2023-02-10>

Submission date: 18-08-2023 | Review date: 12-09-2023

## Abstract

Over-current relays (OCR) are the most popular protecting devices utilized in 6kV mining grids of open-pitch mines, QuangNinh province, VietNam. Depending on time of operation of OCR, there are many operating mode categorized as: Instantaneous OCR, Inverse time OCR, Inverse definite minimum time (IDMT) OCR, Very inverse relays, Extremely Inverse relays. Nowadays, to give protection against: Phase faults, Earth faults, Winding faults (in transformer), most of mining companies using Over-current relays with instantaneous characteristic. This characteristic has the following important features: i) Operates in a definite time when current exceed relay's pick-up/setting up values, ii) Relay's operation is mainly relied on current magnitude, iii) Operating time is constant, iv) There isn't any intentional time delay, v) The operating currents are progressively increased for the other relays when moving towards the source. Apart from many advantages, there is a significant disadvantage of the relays's operation: when there are faults at the beginning of feeders, OCR with instantaneous characteristic usually has a big-time tripping. Moreover, sometimes there are false trip of OCR because of improper set-up. In this study, an offline method is proposed with simulation in ETAP software to overcome these issues. With Gurobi-Optimizer application, an algorithm for identifying Time Multiplier Setting (TMS) will be employed to generate inverse-time characteristic/inverse definite minimum time characteristic for improving the performance of over-current relay with better discriminative tripping. The proposed method is simulated on ETAP with a 6kV sample skeleton distribution network (in QuangNinh province of VietNam). The demonstrating results are: the prevention of false trip of OCR and the operating time of OCR is reduced.

**Keywords:** over-current relays, open-pitch mines, instantaneous time characteristic, false trip, Time Multiplier Setting

## 1. General introduction of Over-Current relays in 6kV mining grid

### 1.1 The advantages of ORC in mining electric system

For supplying energy, most coal mines in Vietnam utilize 6kV skeleton grids. 6kV electricity is normally feed to distribution boxes for energized motors, pumping system, ventilating system or coal-processing system. Because of high request in energy-supplying reliability, all of 6kV feeders contain at least 2 type of protection relays, among them OCR is the key one that responsible for fast and secured isolating the faults. Like normal medium voltage grids in urban areas, ORCs of 6kV networks must contain the following requirements and advantages [1], [26–29]:

+ Simplicity with reasonable cost: The design of ORCs is relatively simple; their implementation is not so complicated when compared to more other kind of complex protection schemes. They are really cost-effective solutions for detecting and responding to excessive current levels in mining grids.

+ Wide Range of Protection Settings: The protection setting of ORCs is wide and flexible, they could offer a wide value of adjustable settings, allowing customization based on the specific requirements and characteristics of the mining grid. These flexible characters enable operators/engineers to optimize the relay's performance for different fault levels.

Versatility: The utilization of OCR is wide with various types of electrical apparatus and systems, making them versatile in mining grid applications. Some popular utilization could be: motors protection, transformers protection, feeder protection, and other components within the mining infrastructure.

High-speed tripping: ORCs could provide rapid fault detection and response. When properly coordinated and set, they can quickly isolate faulty sections and minimize downtime, reducing the risk of equipment damage and improving the reliability of the grid.

Compatibility with digital control Systems: Most new modern ORC could be integrated with digital control/monitoring systems, such as annunciators or remote monitoring devices. This integration is important and allows the operator for real-time monitoring and abnormal/fault identification, aiding in troubleshooting and maintenance activities within the mining grid. According to [1], [31] ORCs installed in 6kV feeder must be integrated with SCADA systems, providing remote monitoring and control capabilities. This integration enables real-time monitoring of relay status, fault indications, and alarms, allowing operators in mines to promptly respond to abnormal conditions or faults in the mining grid. Hence, they enhance situational alarming and facilitates efficient decision-making.

### 1.2 The problems of present ORCs system in 6kV grid of Vietnamese coal mines

Because of insufficient investment, 6kV grids of most Vietnamese coal mines are equipped ORCs with instantaneous time-characteristics. Because of the containing multi-level tripping, the operation of 6kV feeders ORCs has many disadvantages, particularly the wrong tripping could sometimes arise that lead to big economical damage caused by de-energized.

Other disadvantages of ORCs in 6kV grid of Vietnamese coal mines could be listed as follow:

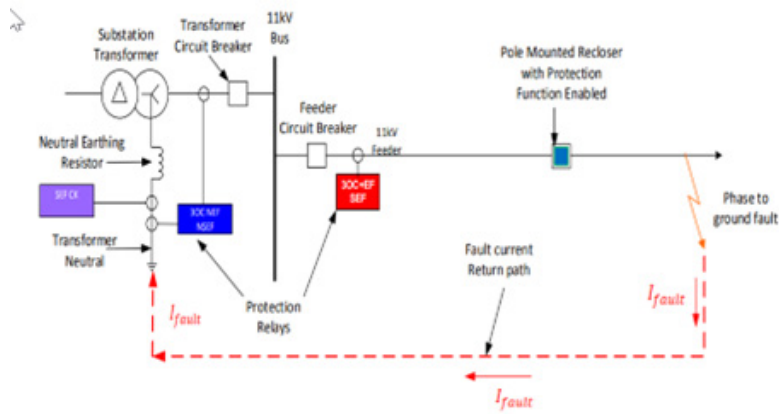

Fig. 1. Routine of earthing current in MV grids

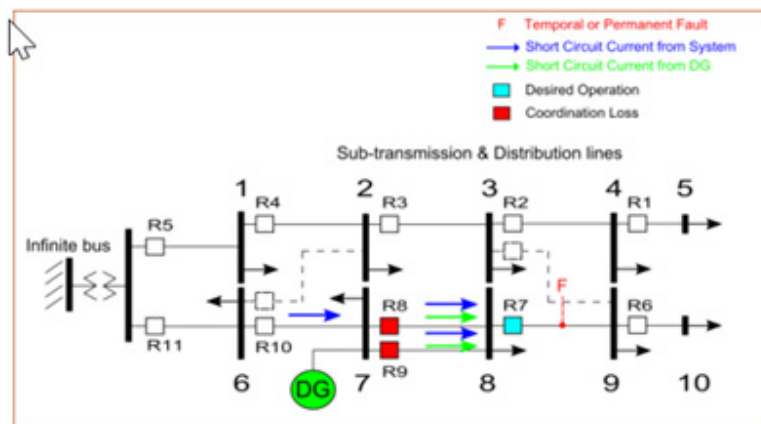

Fig. 2. Directional fault currents with distributed source

+ Delayed response time: OCRs operate based on the detection of current levels exceeding a predefined threshold [12, 13, 30]. However, depending on time-characterized [12, 30], the relay could perform a delayed response time before initiating a tripping procedure. This delay can be problematic in situations where a quick and immediate response is required, such as during fault conditions.

+ Discriminative tripping/Inaccurate coordination: Because OCRs are typically coordinated to ensure selective operation, it means that only the OCR closest to the fault must detect and send tripping signal to circuit breaker to isolate the faulty part of system. However, achieving discriminative tripping could be great challenge due to the OCRs employed different time characteristics of relays and the complexity of 6kV mining network configurations. Improper OCR coordination might result in unnecessary or wrong tripping. Consequently, the overall 6kV system reliability and performance are significantly affected.

+ Limited sensitivity: OCRs have a predefined pick-tripping-up current threshold above which they initiate the trip signal. However, the threshold may not be sensitive enough to detect low-level faults (earthing current) [2, 3, 4] or incipient faults (for instance earthing current which is over 90% of the total faults in 6kV mining grids). Consequently, these relays may not obtain adequate protection in certain scenarios. Figure 1 presents the routine of earthing current in MV [2] (11kV-similarly in 6kV of coal mines). Depending on connection diagram of 35/6kV transformer's neutral point (delta connection [1]), detecting current value could not initiate the relay located at the beginning of feeder.

The sensitivity of OCRs is also affected by direction of fault current [16,17], in Figure 2 [16], because of distributed generator, value and direction of fault currents might not be "strong" enough for initiate the OCRs. This fact is similar to the manner of 6kV surface mines, where there are dozens electric excavators operated as distributed generator [32].

+ Lack of directional sensing: OCRs typically do not have or incorporate directional sensing capabilities themselves. They cannot distinguish between fault currents flowing into or out of the protected zone. This limitation [16, 18, 19] can result the incorrect tripping during faults heppening on the non-protected side, causing to inefficient fault isolation and leading to potential damage of parts of the system.

+ Vulnerability to power system changes: OCRs are designed most relied on specific system parameters. Under certain condition, if the structure of the system is, such as the addition of new equipment or system islanding configuration, the relay settings may become inappropriate or inadequate. Consequently, OCRs' the reliability and effectiveness might be compromised.

+ Hardly detect high-impedance faults: When there is a poor connection between conductors or a short circuit containing a high resistance, OCRs could get challenges in detecting high-impedance faults. Since the rms of current in these occasions are relatively small, OCRs may not be able to identify them precisely, leading to potential safety hazards [4, 14].

Despite of above-mentioned disadvantages, in electric grids of Vietnamese mines OCRs are still widely utilized and

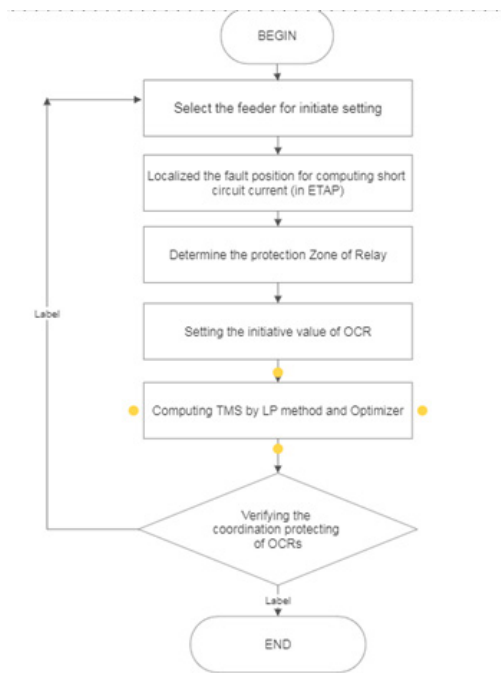

Fig. 3. Proposed Algorithm for identifying TMS of OCRs

provide essential protection in feeders, transformers, 6kV motors. Some technical weaknesses that OCRs must be improve are:

1. Discriminative tripping because of OCRs multi-ladder employed in 6kV networks;
2. Directional tripping if the impact of electric excavators is great.

There are many methodologies [5-11] to compute or optimize the operation of OCRs for logical coordination. But with skeleton grids, choosing the appropriate time curve from 4 basic type of curves [14, 29, 30] could be implemented by combination of Matlab programming and ETAP utilization. The following parts of this paper present an algorithm using Gurobi Optimizer combined with ETAP simulation to calculate the time factors for all OCRs installed in 3 or 4 layers of 6kV grids. The testing results will be simulated for obtaining time curves which is suitable for relay setting which protect both feeders and transformers of mines.

## 2. Identifying Time Multiplayer Setting (TMS) of OCRs

At present, in Vietnamese 6kV mining grids, because of many historic reasons, most of OCRs settings are difinte time characters for all protection level. Consequently, the time delayed tripping is the greatest issue that must be solved.

Other challenge is the identification of Time Multiplayer Setting (TMS) as wel as time ladding interval ( $\Delta t$ ) of OCRs. Proper TMS identification could avoid the wrong tripping (backup OCR trips before essential OCR. Many researches shown in [5-10] focus on indentifying TMS as well as finding method for optimal coordination of OCRs. Each above propose has their individual advances, however refer to the skeleton structure of 6kV mining grids this part propose Linear Programming Algorithm, it will be embeded into Gurobi Optimizer in ETAP software [21] for testifying. According to [22] tripping time of OCR installed in skeleton feeder is calculated as equation (1):

$$t = \frac{0,14}{(I_{nm} / I_s)^{0,02} - 1} TMS \quad (1)$$

Whereas:  $I_{nm}$  -3-phase short cirtcuit current  
 $I_s$  -Setting value

For identifying the value of TMS, a Linear Programme Algorithm is applied, in which an objective function  $f(x)$  (equa. (2)) is solved to obtain its minimum value, the constraint of the function is shown in equation (3) [19, 20].

$$f(x) = \sum_{j=1}^n c_j x_j \rightarrow \min \quad (2)$$

$$\sum_{j=1}^n a_{ij} x_j = b_i; \quad x_j \geq 0 \quad (3)$$

Where:

$a_{ij}$  is the element of constraint matrix A;

$b$  is the vector of freedom parameter;

$x = (x_1, x_2, \dots, x_n)$  is the optimal results of equation (2) which meet the constraint (3).

For satisfying the discriminative tripping, other constraints are considered [15, 21, 22, 23]:

Additional constraint 1: time bias between essential OCR ( $T_{iN}$ ) and back up ( $T_{jN}$ ) when there is a fault at N.

$$T_{jN} - T_{iN} \geq \Delta t \Rightarrow K_{jN} TMS_j - K_{iN} TMS_i \geq \Delta t \quad (4)$$

Additional constraint 2: TMS of each relay:

$$TMS_{\min_i} \leq TMS_i \leq TMS_{\max_i} \quad (5)$$

Additional constraint 3: TMS must be in the range of  $T_{\min_i}$  and  $T_{\max_i}$  which are listed in specification of each OCR:

$$T_{\min_i} \leq T_i \leq T_{\max_i} \quad (6)$$

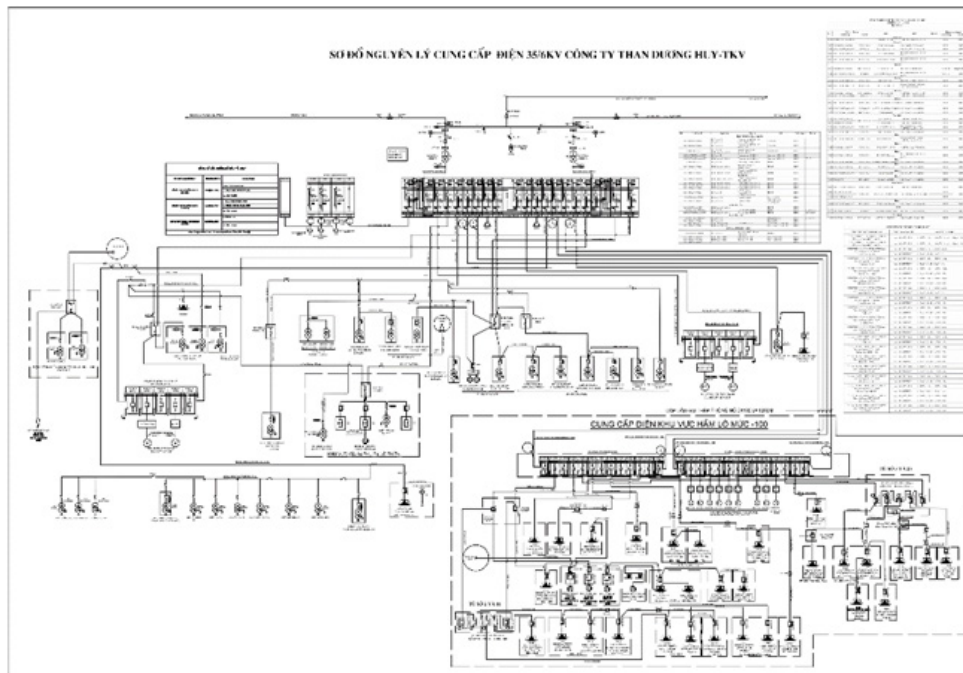

Fig. 4. Single line diagram of 6kV grid of DuongHuy coalmine (VietNam)

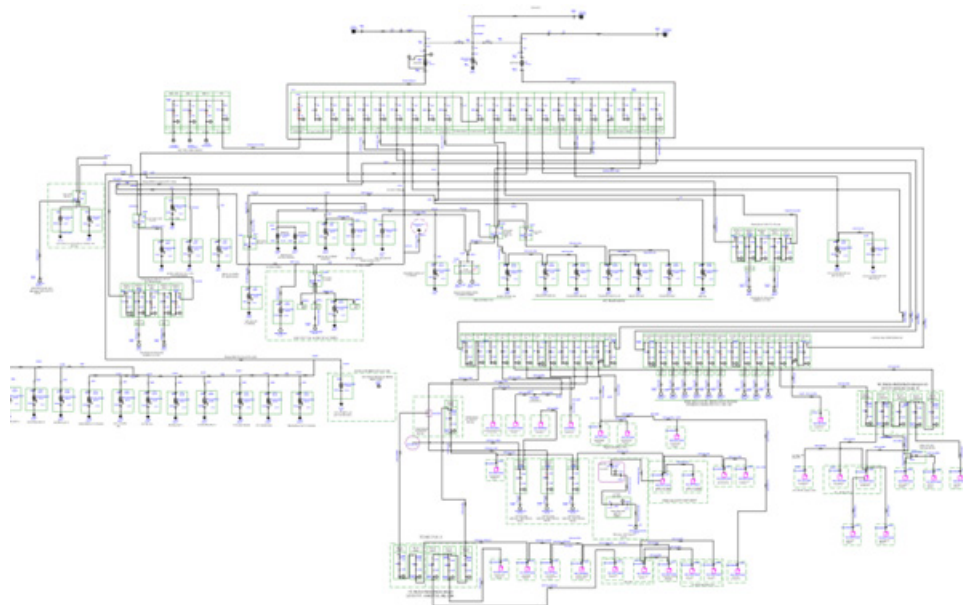

Fig. 5. Simulation diagram in ETAP of 6kV grid of DuongHuy coalmine (VietNam)

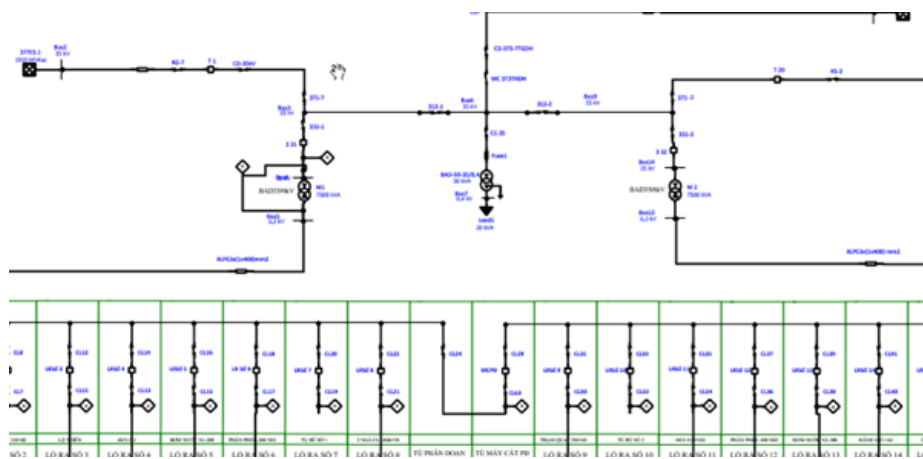

Fig. 6. The first OCRs employed in 6kV feeders



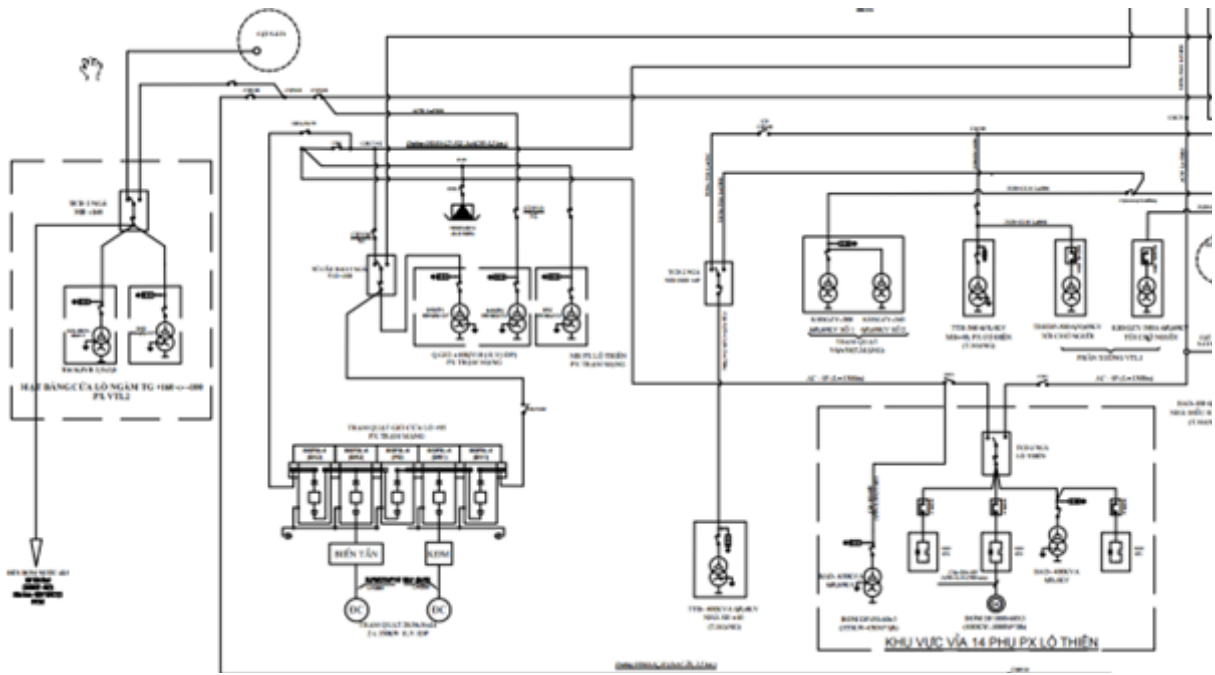

Fig. 7a. Single line diagram of 2nd OCRs layer in 6kV feeders

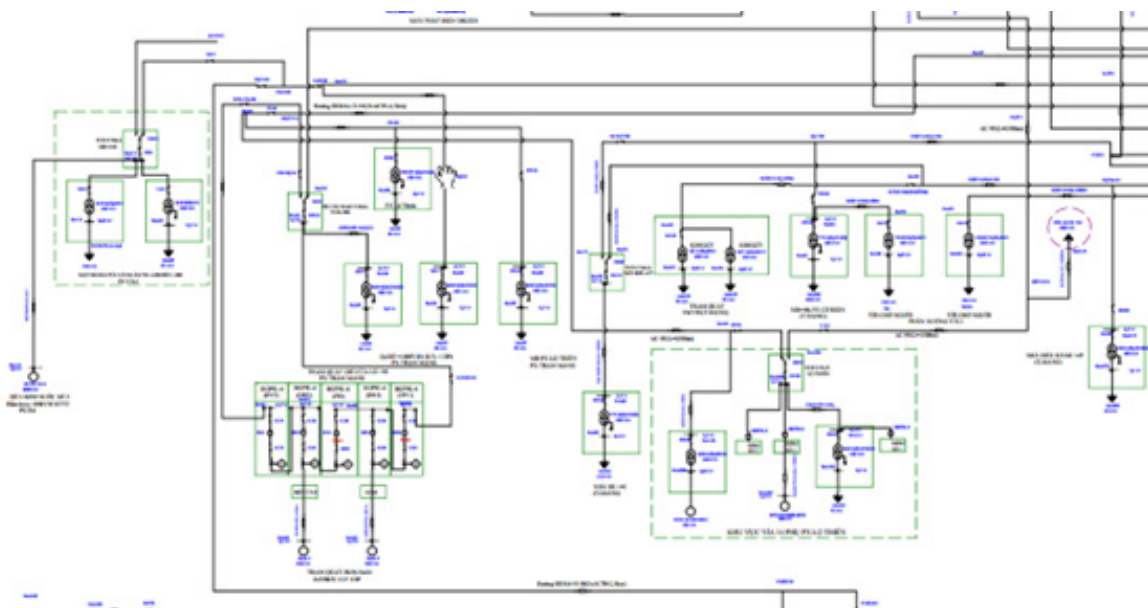

Fig. 7b. Simulation diagram of 2nd OCRs layer

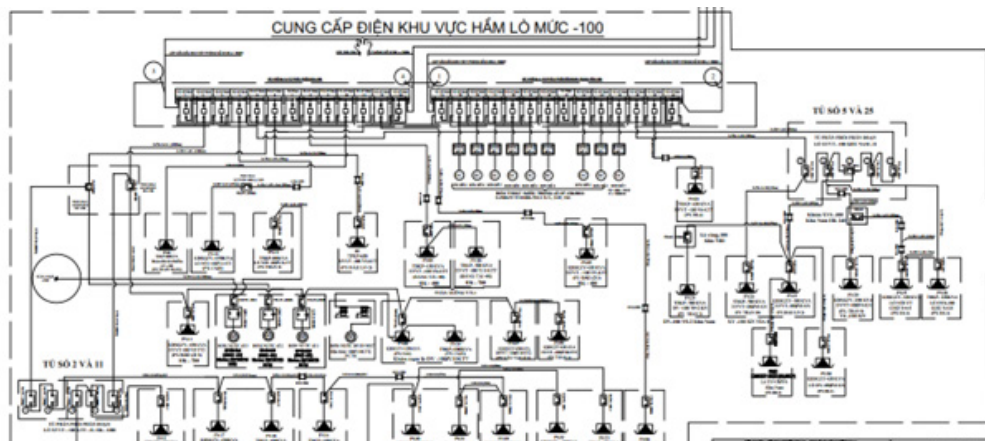

Fig. 8a. Single line diagram of 3rd OCRs layers in 6kV feeders

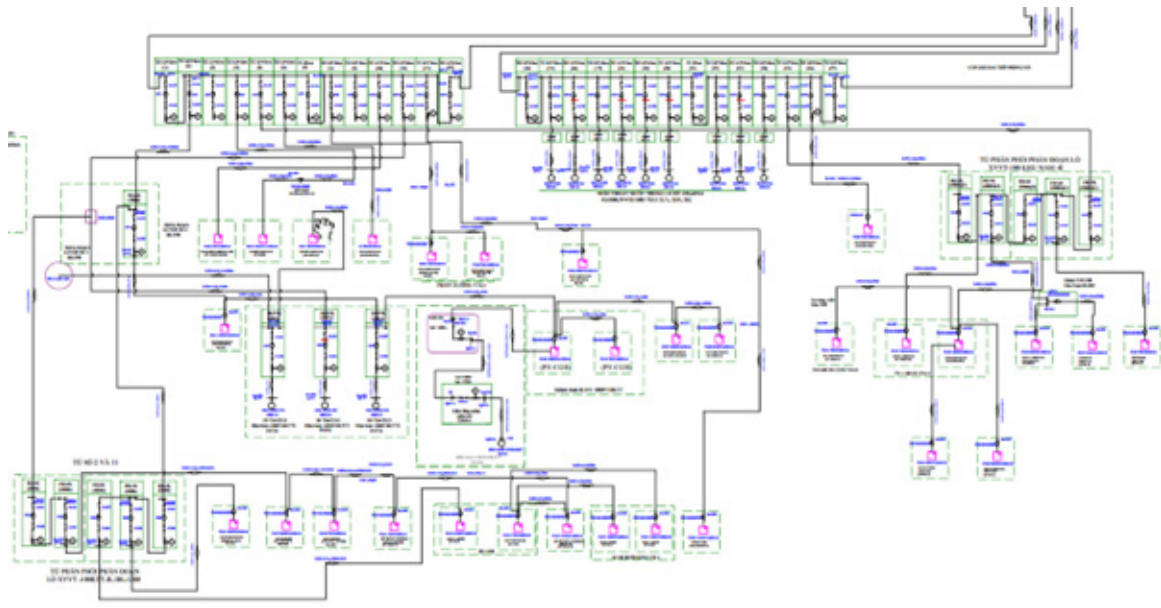

Fig. 8b. Simulation diagram of 3rd OCRs layer

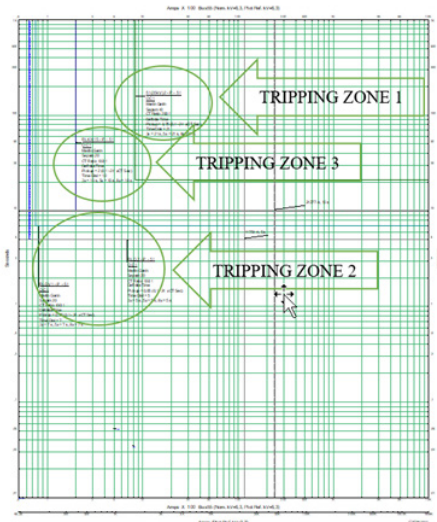

Fig. 9. The Definite Time Curve of OCR showing huge delay tripping

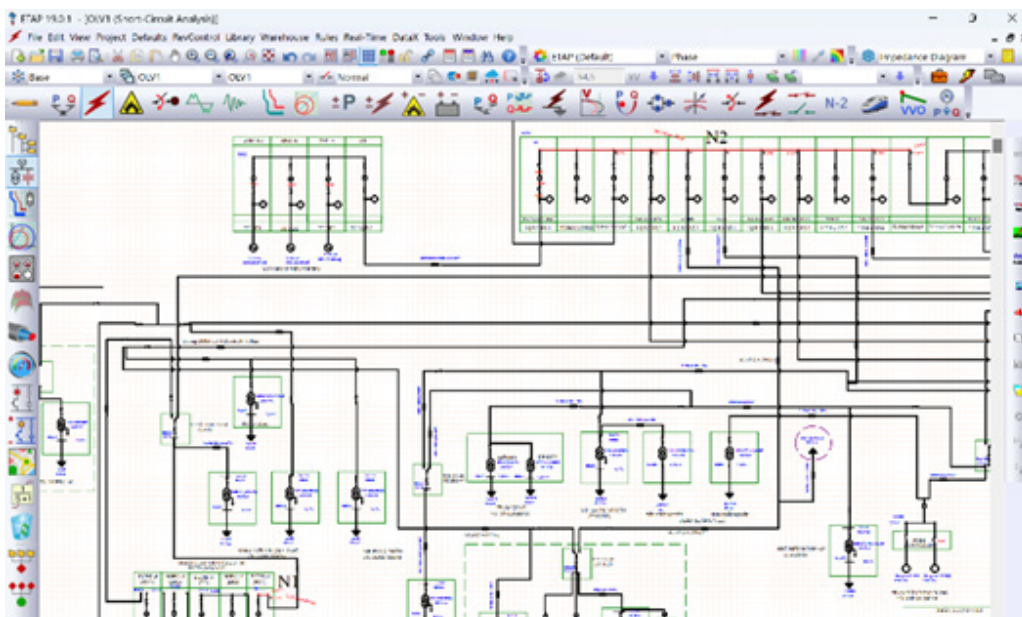

Fig. 10. Simulation of Fault currents calculation

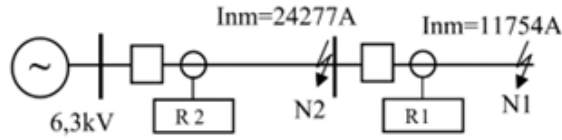

Fig. 11. Simplification of the routine and value of fault currents

Tab. 1. Value of matrix converted into simplex-method

Relay	RLQ2 (Zone 1)	RLDV1 (Zone 2)	RLKH15 (Zone 3)	51(35kV)2 (Back up at transformer substation)
TMS	0,1	0,13	0,2617	0,345
t	t <sub>1</sub> =0,1316	t <sub>2</sub> =0,4315	t <sub>3</sub> =0,7316	

Tab. 2. Values of TMS obtained from Simplex-Method

TMS1	TMS2	S1	S2	S3	P	b
-1,316	1,649	-1	0	0	0	0,3
1	0	0	-1	0	0	0,1
0	1	0	0	-1	0	0,1
1,316	1,39	0	0	0	1	0

If the time-curve characteristic is Definite Time (DT) or Inverse definite minimum time (IDMT), Objective function  $f(x)$  expressed in (1) is solved as:

$$\min C = \sum_{i=1}^n t_i = \sum_{i=1}^n K_{iN} TMS_i \quad (7)$$

Basing on above equations, an algorithm is proposed in figure 3. In the figure, if there are multi-layers OCRs in a feeder, a factor K of OCR numbered I is calculated as equation (8) [21, 23].

$$K_{iN} = \frac{0,14}{(I_{iN} / I_{si})^{0,02} - 1} \quad (8)$$

Where:  $I_{iN}$  – Fault current of OCR numbered i;  
 $I_{s,i}$  – Setting current of OCR numbered i.

### 3. Simulation and results

#### 3.1 A case study for a typical 6kV grid of DuongHuy coal mine of VietNam

Algorithm in figure 3 will be applied for 6kV of Duong-Huy coal mine. The criminative operation of relays is proved and verified with simulation in ETAP. Single line diagram of the mine is presented in figure 4. A Simulated diagram on ETAP is expressed in figure 5.

Simulation parameters of the grid are: 2 main 35/6kV transformers with each one capacity of 7,5MVA, the low voltage of transformers is 6kV, total LV load is 5MW. There are four layers of OCR which located at the beginning feeders shown in Figure 7, 8, 9 and 10.

In these figures: 7a, 8a present single line diagram of the grid, 7b 8b corresponding are Simulation diagrams in ETAP.

At present, DuongHuy coal mine company utilize Sepam S20 relay [24, 25] for over current protection. The relay exhibits DT curves [30], the tripping time at 2nd layer (figure 7b) is 10 second, consequently the tripping time at 1st layer (figure 6-6,3kV bus bar) is 21 second. Hence, when there is a short-circuit at 15-distribution box (ending of 1st layer), the OCR of second layer denies its trip. This fact leads to the fact that the eliminate time of fault current is so great that could harm to 6kV cables and transformer. The expression of curves is shown in figure 9. Other consequence is the relay discrimi-

native operation, the tripping time of zone 3/layer 3 is bigger than one of zone 2/layer 2. This fact is really very “annoyed” to operator because of wrong isolation the fault parts of the system.

To avoid this huge delay-tripping as well as criminative tripping, applying the algorithm presented in part 2, IDMT curves are employed. The task of LP method is to determine TMS values of all 3 layers. The provement rely on the following steps:

- (1) Calculate the fault currents at beginning of layer 1 and layer 2 (two biggest values of all layers);
- (2) Perform objective function and constraint matrix;
- (3) Employing the Optimizer for identifying TMS;
- (4) Simulate in ETAP for identify the series of IDMT curves for visual provement of relays in all layers.

#### 3.2 Simulation and Results

In figure 10, locations of fault currents are exhibited, N1 and N2 are the beginning point of each feeder, relays R1 and R2 are correspondingly main protection one and back up one of each routine. The the results of faults currents and simplization of the routine is shown in figure 11.

\* Step (1): Utilizing equation (8) [21], [23], when faulted at N<sub>1</sub>, K factors of main relay R<sub>1</sub> and back up relay R<sub>2</sub> are computed as:

$$K_{11} = \frac{0,14}{(I_{N1} / I_{S1})^{0,02} - 1} = \frac{0,14}{(11754 / 75)^{0,02} - 1} = 1,316$$

$$K_{21} = \frac{0,14}{(I_{N1} / I_{S2})^{0,02} - 1} = \frac{0,14}{(11754 / 200)^{0,02} - 1} = 1,649$$

When faulted at N<sub>2</sub>, K factors of main relay R<sub>2</sub>:

$$K_{22} = \frac{0,14}{(I_{N2} / I_{S2})^{0,02} - 1} = \frac{0,14}{(24277 / 200)^{0,02} - 1} = 1,39$$

\* Step (2) Forming the constraint matrix.

The Objective function is:

$$\min C = K_{11} \times TMS_1 + K_{22} \times TMS_2$$

With constraint:

$$K_{21} \times TMS_2 - K_{11} \times TMS_1 \geq 0,3$$

$$TMS_1 \geq 0,1$$

$$TMS_2 \geq 0,1$$

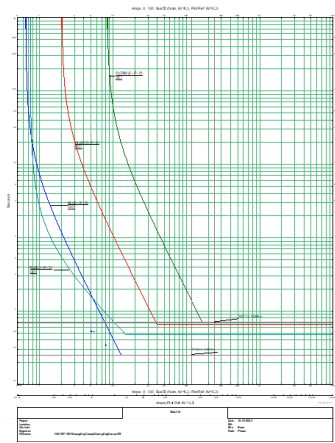

Fig. 13. The provement of criminative tripping of OCRs on 6kV grid

Tab. 3. Results of TMS identification-Algorithm (TIA) for some typical mines in VietNam

Name of coal mines In VietNam	Tripping time before applying TIA (s)	Discriminative problem	Tripping time after applying TIA	Number of protection zones	Tripping time of Zone/layer 1	Tripping time of Zone/layer r 1	Tripping time of Zone/layer r 1
HaLam	16	YES	0,862	2	0,236	0,862	-
NuiBeo	15	NO	2,063	3	0,166	0,568	2,063
ThongNhat	20	NO	0,968	2	0,663	0,968	-
CaoSon	22	YES	1,267	3	0,568	0,969	1,267
CocSau	16	YES	1,689	3	0,656	1,086	1,689
QuangHanh	18	YES	2,078	3	0,985	1,389	2,078

Adding an auxiliary variable  $P$ , and  $S_1, S_2, S_3$  (which are not negative) to transfer the above math inequality become an equality:

$$\begin{aligned} 1,316 \times TMS1 + 1,39 \times TMS2 + P &= 0 \\ 1,649 \times TMS2 - 1,316 \times TMS1 - S_1 &= 0,3 \\ TMS1 - S_2 &= 0,1 \\ TMS2 - S_3 &= 0,1 \end{aligned}$$

Four equality equations exhibit values shown in table 1 which express the simplex-method.

From Table 1 values of factors matrix could be obtained:

$$C = [1,316 \ 1,649 \ 0 \ 0 \ 0];$$

$$B = [0,3 \ 0,1 \ 0,1];$$

$$A = \begin{bmatrix} -1,316 & 1,649 & -1 & 0 & 0 \\ 1 & 0 & 0 & -1 & 0 \\ 0 & 1 & 0 & 0 & -1 \end{bmatrix}$$

\* Step (3): Finding TMS by Optimizer Linprog in Matlab:

`options=optimset('LargeScale','off','Simplex','on');`

`[TMS,FVAL,EXITFLAG,OUTPUT]=linprog(C,[],[],A,B,zeros(size(C)),[],[],options).`

$$t1 = 1,316 \cdot TMS(1)$$

$$t2 = 1,649 \cdot TMS(2)$$

$$\Delta t = t2 - t1$$

Results are deducted as:

$$TMS = [0,1 \ 0,2617]$$

$$t1 = 0,1316$$

$$t2 = 0,4315$$

$$\Delta t = 0,3$$

Those values are immersed into ETAP, curves are performed in figure 13. Values of TMS for 3 protection zones/layers are given in table 2. It is easily seen in table 2 that the delayed time is reduced significantly (only 0,7316s compared with 21s in above analysis). Corresponding to 1 value of fault current (IN) the computing process of TMS showed that the tripping times ( $t_1, t_2, t_3$ ) are logically criminative ( $t_1 < t_2 < t_3$ ).

Implementing this Algorithm to other 6kV mining grids, the effect of IDMT curves is shown in table 3.

#### 4. Conclusion

Overcurrent relays play very important role in 6kV mining grids of VietNam. Along with reforming process for replacing electromechanics relays by digital ones, the requirements of relay system smart utilization are the big matters that all mines must solved. By applying the programming in Matlab, combined with simulation in ETAP based on proposed TMS Identification Algorithm (TIA), the paper shown the following advantages on the field of improving the operation of OCRs in VietNam coal mines:

- + The proposed TIA is suitable for all skeleton 6kV mining grid despite of the complexity of protection zone;

- + TIA could help operator/technician in mine to transfer IT curves of overcurrent relay into its IDMT without any wrong operation;

- + The problem of delayed-tripping and discriminative tripping are completely cleared in all biggest coal mines in VietNam.

- + Results deducted from ETAP are visualable for operating, monitoring and designing the relay system in 6kV grids.



## Literatura – References

1. QCVN 01:2011/BCT, 2011. Vietnam National regulation on safety Mining, <http://www.kiemdinh.vn/upload/files/QCVN%2001-2011-BCT%20An%20toa%CC%80n%20trong%20khai%20tha%CC%81c%20than%20h%C3%A2%C%80m%20lo%CC%80.pdf>
2. Narayan, Sanjay (2019) Earthing Systems and Earth Fault Protection in Power System Distribution Network. Research Project report, University of Southern Queensland. [https://eprints.usq.edu.au/43125/12/Narayan\\_S\\_Quinton\\_Redacted.pdf](https://eprints.usq.edu.au/43125/12/Narayan_S_Quinton_Redacted.pdf)
3. Ghanbari, T., Samet, H., & Ghafourifard, J. (2016). New approach to improve sensitivity of differential and restricted earth fault protections for industrial transformers. *IET Generation, Transmission & Distribution*, 10(6), 1486-1494. <https://doi.org/10.1049/iet-gtd.2015.1343>
4. Topolánek, D., Toman, P., Orságová, J., Kopicčka, M., & Dvořák, J. (2014). The evaluation of overvoltage during short-time additional earthing of healthy phase for fault location in MV networks. *Developments in Power System Protection*, 48-56. <https://doi.org/10.1049/cp.2014.0160>
5. A. E. Emanuel and E. C. Lalas, "Evaluation of Overcurrent Relay Settings Using a Genetic Algorithm," *IEEE Transactions on Power Delivery*, vol. 17, no. 1, pp. 85-91, Jan. 2002.
6. Y. M. Atwa, E. F. El-Saadany, and M. M. A. Salama, "Optimal coordination of overcurrent relays using a fuzzy-based immune algorithm," *IEEE Transactions on Power Delivery*, vol. 22, no. 4, pp. 2283-2290, Oct. 2007.
7. H. R. Hedayati-Dehkordi and G. R. Yousefi, "Optimal coordination of overcurrent relays using a novel hybrid approach based on improved particle swarm optimization and harmony search algorithms," *International Journal of Electrical Power & Energy Systems*, vol. 54, pp. 94-103, May 2014.
8. M. J. Hossain and M. A. Mahmud, "Optimal coordination of overcurrent relays using particle swarm optimization," *IEEE Transactions on Power Delivery*, vol. 27, no. 2, pp. 984-992, April 2012.
9. S. K. Goswami and S. Das, "Overcurrent relay coordination using bacterial foraging optimization algorithm," *IET Generation, Transmission & Distribution*, vol. 6, no. 12, pp. 1186-1197, Dec. 2012.
10. S. G. Haghjoo and H. Lesani, "A new protection coordination algorithm for microgrids using overcurrent relays based on harmony search," *IEEE Transactions on Smart Grid*, vol. 5, no. 6, pp. 3012-3020, Nov. 2014.
11. K. S. Pandya, R. K. Saket, and V. R. Prajapati, "Optimal coordination of overcurrent relays using artificial bee colony algorithm," *International Journal of Electrical Power & Energy Systems*, vol. 70, pp. 192-200, Jan. 2015.
12. Overcurrent relay and its characteristic, Electrical concept, Internet access at <https://electricalbaba.com/over-current-relay-and-its-characteristics/>
13. Type of overcurrent relay, Electrical Deck, Internet access at:
14. <https://www.electricaldeck.com/2021/09/types-of-overcurrent-relay.html>
15. Vincent Nsed Ogar, Sajjad Hussain, Kelum A. A. Gamage, (2023), The Use of instantaneous overcurrent relay in determining the threshold current and voltage for optimal fault protection and Control in transmission line, *Signals-Volume 4 (1)*, page 137-149.
16. <https://doi.org/10.3390/signals4010007>
17. 15. Mahdi Ghotbi-Maleki, Reza Mohamadi Hamid Javadi, Method to solve false trip of Non-Directional overcurrent relays in radial networks equipped with distributed generator, *IET Generation, Transmission and Distribution* 13 (4) DOI: 10.1049/iet-gtd.2018.5610
18. <https://ietresearch.onlinelibrary.wiley.com/doi/full/10.1049/iet-gtd.2018.5610>
19. Meng Yen Shih, Arturo Conde, "An Adaptive Overcurrent Coordination Scheme to improve relay sensitivity and overcome drawbacks due to distributed generation in smart grids", *IEEE Transaction on Industry Applications*, 2016 DOI: 10.1109/TIA.2017.2717880
20. <https://ieeexplore.ieee.org/document/7954715>
21. Cheung, H., Hamlyn, A., Wang, L., et al.: 'Investigations of impacts of distributed generations on feeder protections'. Proc. IEEE Power & Energy Society General Meeting, Canada, 2009, pp. 1-5
22. Saleh, K.A., Zeineldin, H.H., Al-Hinai, A., et al.: 'Optimal coordination of directional overcurrent relays using a new time-current-voltage characteristic', *IEEE Trans. Power Deliv.*, 2015, 30, pp. 537-544
23. Sarang V. Khond and Gunwant A. Dhokane, Optimum coordination of directional overcurrent relays for combined overhead/ cable distribution system with linear programming technique, *Protection and Control of Modern Power Systems*, 2019.

24. SKeith Brown, Herminio Abcede, Farrokh Shokooh, "Interactive simulation of power system & ETAP application and Techniques" IEEE operation Technology, Irvine, California.
25. Keith Brown, Herminio Abcede, Farrokh Shokooh, "Interactive simulation of power system & ETAP application and Techniques" IEEE operation Technology, Irvine, California.
26. Nguyễn Xuân Hoàng Việt, Role bảo vệ và tự động hóa trong hệ thống điện. Nhà xuất bản Đại học Quốc Gia TP.HCM, 2005.
27. A. Akhikpemelo, M. J. E. Evbogbai and M. S. Okundamiya, Overcurrent relays coordination using MATLAB model, Journal of Engineering and Manufacture Technology JEMT 6 (2018) 8-15.
28. <https://www.se.com/vn/vi/download/document/PCRED301005EN/>
29. <https://www.se.com/vn/vi/download/document/PCRED301006EN/>
30. IEEE Standard C37.112: "IEEE Guide for the Application of Protective Relays Used for Abnormal Frequency Load Shedding and Restoration."
31. IEC 60255-151:2019: "Electrical relays - Part 151: Power system protection and control devices."
32. IEEE Standard C37.2: "IEEE Standard Electrical Power System Device Function Numbers, Acronyms, and Contact Designations."
33. IEC 60255-1:2018: "Measuring relays and protection equipment - Part 1: Common requirements."
34. R. R. Williams, G. Benmouyal, and A. D. Singh, "Understanding overcurrent coordination curves," IEEE Transactions on Power Delivery, vol. 17, no. 3, pp. 724-729, July 2002.
35. Coal Mining Safety and Health Regulation 2017, Part 4 Electrical activities, equipment and installations. <https://www.legislation.qld.gov.au/view/pdf/asmade/sl-2017-0165>
36. Thanh, L.X., & Bun, H.V. (2022). Identifying the factors influencing the voltage quality of 6kV grids when using electric excavators in surface mining. Mining of Mineral Deposits, 16(2), 73-80. <https://doi.org/10.33271/mining16.02.073>