

Analysis of the structure of the frame of a trailer for transport of bales of compressed straw in the aspect of minimalization of materials and energy consumption

Dariusz Lodwik, Jerzy Pietrzyk

*Warsaw University of Technology, Faculty of Civil Engineering, Mechanics and Petrochemistry in Płock,
Institute of Mechanical Engineering, Poland
e-mail: dariusz.lodwik@pw.edu.pl, jerzy.pietrzyk@pw.edu.pl*

Received: February 12, 2018; Accepted: March 01, 2018

Abstract. The article presents the development of a structure model and numerical analysis of the trailer frame assembly intended for transporting bales of compressed straw, which may be a potential source of cheap and ecological energy. The aim of the analysis was to minimize the use of construction materials (reduction of the total weight), simplification of manufacturing technology, and thus energy savings in the production and operation. The aforementioned aspects also play a key role in environmental protection issues.

The digital models of frame assemblies were made and subjected to static strength analysis. The structure was evaluated in terms of strength, based on the calculations made using the finite element method. The distribution of simulation parameters in the area of the tested structure made it possible to partially optimize the load-bearing system of the trailer, due to the adopted decision criterion in the form of reduction of the total weight and simplification of the structure, while meeting the limitations resulting from the values of stresses, displacements, safety factor in the admissible range.

Key words: energy minimization, environmental protection, frame, model, MES.

loading, which makes it possible to reduce transport costs in all working conditions.

The subject of deliberations in this paper is the structure model and static numerical analysis of the transport system frame assembly, in order to obtain material savings and to simplify the manufacturing technology, and thus energy savings. For the proposed structural solution, an attempt was made to assess the strength of the structure, based on stress analysis as large as the material properties and the required safety considerations allow. The model was made using a three-dimensional computer image in Autodesk Inventor [4]. Strength calculations were carried out using the finite element method, for the adopted range of decision variables, geometrical and material features of the parts used to build the frame model. In the area of the tested structure, partial optimization of the load-bearing system of the trailer was performed, due to the accepted criterion of reduction of the total weight, while meeting the limitations resulting from the values of stresses, displacements, safety factor in the admissible range.

RESEARCH METHODOLOGY

INTRODUCTION

The use of modern technologies in plant and animal production results in a significant surplus of straw, which can be used, inter alia, as an ecological fuel for energy purposes. Excess straw in Poland is estimated at around 9÷12 million tons, which is equivalent to 5÷7 million tons of hard coal. An inseparable element of the logistic chain of using straw as an ecological fuel is transport. In transporting bales of compressed straw, trailers with an increased loading space are used. The advantages of such a solution is the simplicity of use and the convenience of

The concept of trailer structure has been developed on the basis of a frame made of rectangular steel profiles, supplemented by the structure of a loading platform and supporting walls, limiting the movement of the transported load. The model was supplemented with components offered on the market, creating a full-sized and compact structure of the trailer for transporting bales. The visualization of the developed model of the trailer, in a view with a limited level of detail together with the designation of the basic assemblies subjected to simulation tests in the FEM analysis environment, is shown in the figure 1.

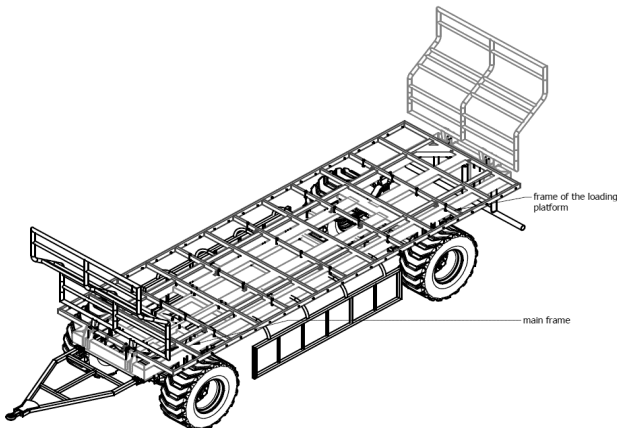

Fig. 1. Digital model of the trailer structure with marked components subjected to FEM analysis

Geometrical models of frames (Fig. 2), developed as spatial parametric 3D structures, in which standard steel profiles were used for construction with closed profile, square and rectangular sections, and sheet for the construction of: nodes and elements fastening the subassemblies of the wheel set, floor covering. The elements shaping the structure of the frames in the notation of structural features have been given appropriate geometric features based on databases of structural shapes, as well as material features. E360 structural steel was adopted in the construction of the frame model. The shaping elements were selected based on the database of standardized Content Center library profiles.

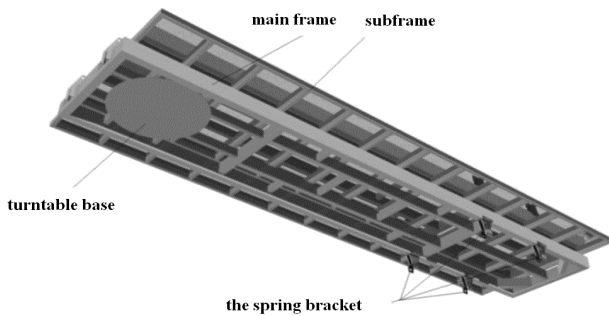

Fig. 2. Geometric model of the load bearing part of the trailer

The structure was written as N set of numbers and functions representing structural features and shaping the elements of the model. Frame models in the construction space were described by a vector [2, 3, 9, 10]:

$$X = (X_1, \dots, X_N) \in E_k. \quad (1)$$

The group of vector coordinates (1) and frame models are set parameters which values have not changed during the numerical analysis and decision variables, which were the quantities selected in the construction process. The set

of decision variables was adopted as a point in the Euclidean space of solutions E_x (2).

$$y = (y_1, \dots, y_N) \in E_x. \quad (2)$$

The assembly was performed using static assembly constraints of the model, taking the degrees of freedom of the frame structure profiles. In the geometric three-dimensional record of the trailer assembly model, a subassembly of the main frame, the frame of the loading platform were separated, which were marked in Figure 1. For these structures, a decision variable belonging to the E_x space was adopted [1, 2, 9, 10]:

$$y = (y_1) \in E_x. \quad (3)$$

where:

y_1 - thickness of the walls of the frame model sections.

For the decision variable y_1 , a discrete range of variability was determined taking into account the market availability of rectangular profiles and pipes (standard types of profiles):

$$y_{1\min} \leq y_1 \leq y_{1\max}. \quad (4)$$

An attempt was made to partially optimize the discussed components. As a function of the objective, a reduction of the total weight of the assembly (mass as a decision criterion) was assumed, while maintaining the external dimensions of steel profiles and the value of safety factor at the required level, and the permissible value of displacement and stresses generated in the analyzed structure.

A model was used for numerical static analysis of the assembly, in which the suspension construction was excluded from the simulation. The model does not take into account the rigidity of the suspension. The bonding of the contacting surfaces made by screw connections has been replaced by contact models that simulate pressures and friction in the joints. For contact pairs between the construction elements of the frame subassemblies, the surface-to-surface contact type with the "bound" attribute (no possibility of relative displacement of components) was used. The structure model was written as a vector of the decision variable $y = (y_1)$, for which a set of acceptable solutions $\emptyset(y)$ was obtained. The optimal solution is that for which the objective function reaches the minimum value, with the assumed criterion of minimum weight of the frame structure $m(y)$:

$$\begin{aligned} y &= (y_1) \in E_D, \\ \emptyset &= \emptyset(y) \subset E_D, \\ \emptyset(y) &= (m(y)), \end{aligned} \quad (5)$$

where:

$m(y)$ =minimum weight.

In order to assess the structure on the basis of the adopted criterion, the restrictions which fulfillment was considered necessary were introduced:

$$\begin{aligned} x_{min} &\geq x_{dop} \\ w_{max}(x, y, z) &\leq w_{dop} \\ \sigma_{Smax} &\leq k_{dop}, \end{aligned} \quad (6)$$

where:

x_{min} - minimum safety factor (referred to the Re yield point), $w_{max}(x,y,z)$ —maximum displacement, σ_{Smax} - maximum normal stress.

For the analyzed systems made of plastic materials, the criterion of safety was the lack of the possibility of permanent deformation. It was considered that the condition for allowing the structure to work is to obtain stresses $\sigma_{Smax} \leq k_r$ (k_r - allowable tensile stress), [2, 7].

Discretization of the analysis area was carried out for the assembly of the beam model, with coating elements and several solid models. In order to map the load locations in the form of bales to the surface of the trailer loading platform (Fig. 3), the floor plane was divided and the contact area between the log and the floor was determined.

The tested structure was subjected to forces, derived from the weight of the transported load, taking into account the force of gravity. The structure was designed for transporting up to 26 bales with a unit weight of $m = 600$ kg each. The ideological distribution of the load from the weight of the load, in relation to the designated strips of the platform floor plane, is shown in Fig. 3.

In strength calculations it was assumed that for each bale of mass m in the lower layer, there is an additional

load in the form m ($m/2 + m/2$), coming from two bales of the upper layer (Fig. 3). The remaining load in the form m ($m/2 + m/2$) coming from the upper bales, decomposes into neighboring lower bales. The entire load acts on the contact plane between the lower bale and the floor, for each bale from the lower layer. The calculation includes the total maximum load (26 bales with a mass $m = 600$ kg each), with a distribution of 92% (24 bales) of the maximum load in the area of contact between the load and the floor, and the remaining load was directed to the support wall brackets (weight of 2 bales). Maximum strength $F=142000$ N, distributed on 6 levels of the loading platform (interaction of 24 bales, stacked one above the other). The load with the value $F1=14000$ N, was applied to the support walls, imaging the interaction of 2 bales. In the construction simulation model, non-displaceable articulated supports were used to simulate a bolt connection between the bracket and the suspension components, a fixed support that reflects the geometry of the loading platform's support by the turntable.

RESEARCH RESULTS

In the calculations, the criterion of optimal frame construction was adopted as a function dependent on the value of the decision variable. The criterion was to minimize the weight of the frame for the proposed structural solution while meeting the strength limitations (6), which is in line with the main objective of the analysis, which is to minimize material consumption and reduce energy during production and operation. The structure made of assemblies was subjected to preliminary simulation tests. The selected research result in the form of a contour map of displacements are shown in the figure 4.

Maximum stresses in the most strenuous point of the structure did not exceed 148 MPa. Fig. 4 shows the local values of the displacement parameter within the examined

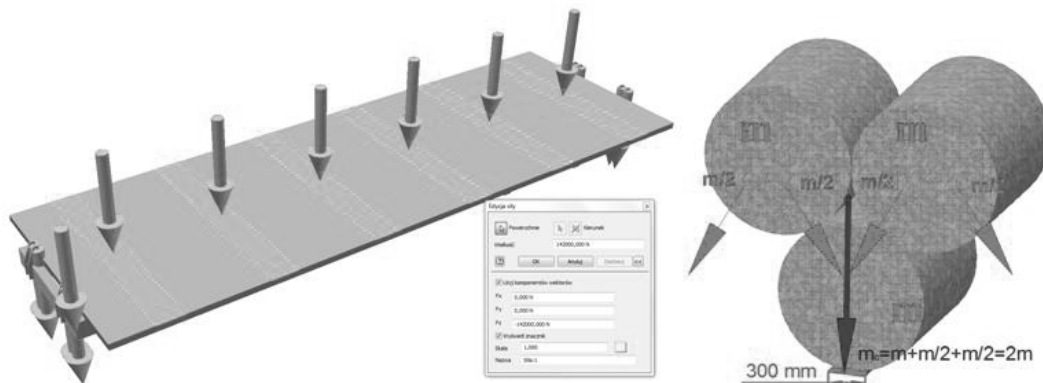

Fig. 3. Loading the transport platform with forces simulating the load weight

unit. The value of the maximum displacement in the tested object was 3.7 mm, which was recorded in the floor plating (sheet with a thickness of 2.5 mm). The reason is the significant value of the load affecting the plane with a small thickness, in the place of maximum deflection of the main frame (central part of the structure).

There was a small value (1.5 mm) deflection of the main and auxiliary frames, which indicates a significant rigidity of the structure and the possibility of introducing partial optimization of the structure.

The minimum value of the safety coefficient (2.03) of a local nature was recorded at the points where the floor

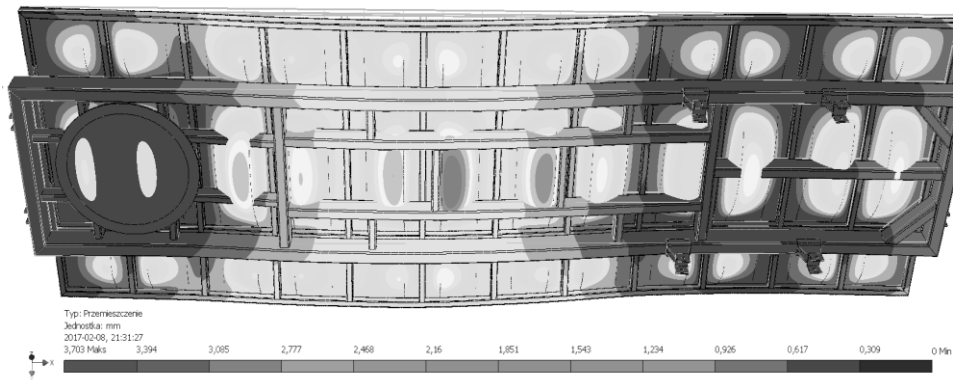

Fig. 4. Distribution of structure displacement - bottom isometric view

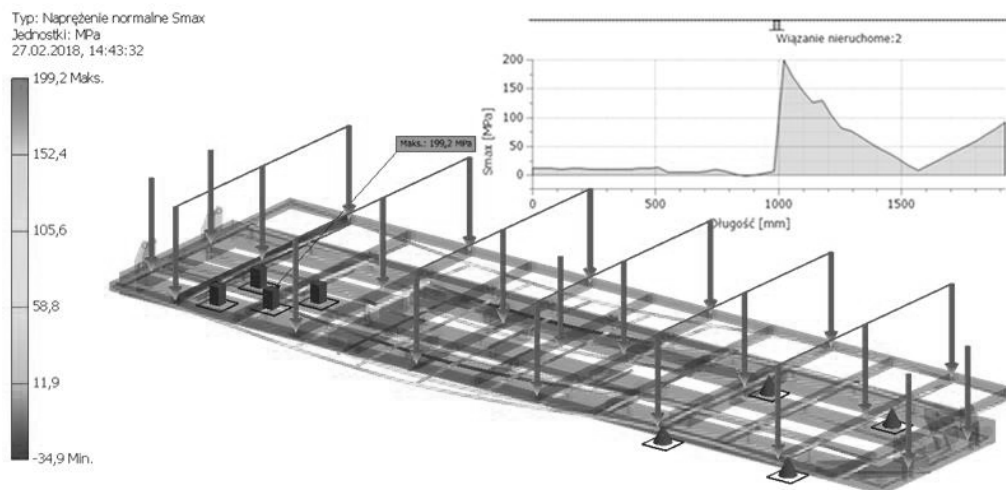

Fig. 5. Distribution of normal stresses S_{max} in the area of the tested model - variant 5

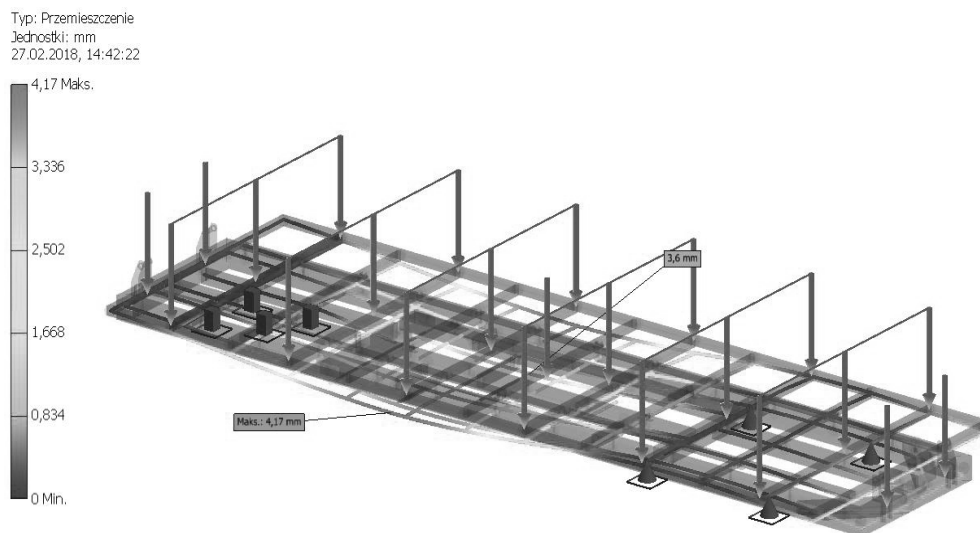

Fig. 6. Distribution of the displacement of the tested object - variant 5

meets the beams of the subframe. Large values of the safety coefficient were observed in the load-bearing elements of the structure (7÷15), which indicates the possibility of attempting to partially optimize the discussed components. The load bearing system of the trailer was transferred to the framework analysis environment.

As a result of the adaptation of the system, 40 beams, 261 nodes, and 105 rigid connections were obtained. At the place where the main frame was connected to the turntable base, a system of 4 non-displaceable supports was used, and 4 fixed pivot supports were installed in the suspension mounting points and the load distribution in the area of the tested frame system was mapped in the form of continuous load (10 N/mm), where the value of previously assumed loads was taken into account, and the length of the beams directly supporting the bales.

In the main part of simulation tests, calculations were made for various design variants. The simulation procedure was carried out for varying wall thicknesses of the profiles used in the structure, in accordance with their standard type series. The adopted assessment criterion was to obtain a

structure with the lowest possible mass, while meeting the strength limitations (6). The selected research results, a set of permissible solutions $\emptyset(y)$, meeting the strength criteria are summarized in the table 1.

The effect of partial optimization was to reduce the total weight of the tested frame system by about 187 kg (variant 5). It was considered that the construction meets all the necessary conditions, ($\sigma_{S_{max}} \leq 200$ MPa, $w_{max}(x,y,z) \leq 5$ mm, $x_{min} \geq 1,5$). Figure 5 presents the distribution of normal stresses S_{max} , for variant 5 of simulation calculations.

Maximum value $\sigma_{S_{max}} = 199,2$ MPa of normal stresses, occurs only in the area of non-sliding fixed support, which may be caused by the local stiffening of the longitudinal beam structure, for which a displacement of $w = 3.6$ mm has been recorded in the central part of the main frame structure (Fig. 6). In the remaining part of the structure, stresses not exceeding the values $\sigma_{S_{max}} = 110$ MPa were recorded. Maximum deflection with a value $w_{max} = 4,17$ mm (fig. 6), occurs only in the central part of the auxiliary structure.

Table 1. Results of simulation tests for selected construction variants

Steel E360		Re=365 MPa		Rm=690 MPa		Young's modulus G=210 GPa	
		variant 1	variant 2	variant 3	variant 4	variant 5	
No. of pieces	Length [mm]	Beams markings					
Main frame							
2	7400	200 x 100 x 5	200 x 100 x 4	200 x 100 x 4	200 x 100 x 4	200 x 100 x 4	
2	1400	200 x 100 x 5	200 x 100 x 4	200 x 100 x 4	200 x 100 x 4	200 x 100 x 4	
2	3320	160 x 80 x 5	160 x 80 x 4	160 x 80 x 4	160 x 80 x 4	160 x 80 x 4	
2	1860	160 x 80 x 5	160 x 80 x 4	160 x 80 x 4	160 x 80 x 4	160 x 80 x 4	
2	1200	160 x 80 x 5	160 x 80 x 4	160 x 80 x 4	160 x 80 x 4	160 x 80 x 4	
2	504	160 x 80 x 5	160 x 80 x 4	160 x 80 x 4	160 x 80 x 4	160 x 80 x 4	
1	1860	120 x 60 x 3	120 x 60 x 3	120 x 60 x 4	120 x 60 x 4	120 x 60 x 4	120 x 60 x 2,5
2	1200	120 x 60 x 3	120 x 60 x 3	120 x 60 x 4	120 x 60 x 4	120 x 60 x 4	120 x 60 x 2,5
2	520	100 x 60 x 3	100 x 60 x 3	100 x 60 x 3	100 x 60 x 3	100 x 60 x 3	100 x 60 x 2,5
4	260	100 x 60 x 3	100 x 60 x 3	100 x 60 x 3	100 x 60 x 3	100 x 60 x 3	100 x 60 x 2,5
Auxiliary frame							
4	7200	80 x 40 x 3	80 x 40 x 3	80 x 40 x 3	80 x 40 x 2,5	80 x 40 x 2	
2	2400	80 x 40 x 3	80 x 40 x 3	80 x 40 x 3	80 x 40 x 2,5	80 x 40 x 2	
11	2300	80 x 40 x 3	80 x 40 x 3	80 x 40 x 3	80 x 40 x 2,5	80 x 40 x 2	
Total mass		1046,5 kg	971 kg	986 kg	934 kg	859 kg	

Displacement W_{max} [mm]	Main frame	1,9	3,3	2,5	3,2	3,6
	Auxiliary frame	2,79	3,8	3,65	3,73	4,17
Normal stresses	Smax	102,8 MPa	179 MPa	153 MPa	153,9 MPa	199 MPa
	Smin	24,5 MPa	27,4 MPa	26,9 MPa	29,5 MPa	32,4 MPa
	Smax(Mx)	92,6 MPa	180,4 MPa	157,8 MPa	159,8 MPa	200 MPa
	Smax(My)	59,9 MPa	113,9 MPa	93,9 MPa	94,4 MPa	133,3 MPa
Transverse stresses	Tx	88,9 MPa	117,9 MPa	116,2 MPa	128,3 MPa	142 MPa
	Ty	17,5 MPa	41,1 MPa	32,2 MPa	32,4 MPa	48,5 MPa
Torsional stresses	T	14,7 MPa	22,8 MPa	19,9 MPa	20,2 MPa	26,3 MPa
Minimum safety factor x_{min}		3,5	2	2,4	2,4	1,8

CONCLUSIONS

Based on the analysis of the obtained results, it was found that:

- the presented variants of the trailer frame structure are included in the group of acceptable solutions. In all cases, the safety criterion expressed in the accepted strength conditions is met ($\sigma_{Smax} \leq 200$ MPa, $w_{max}(x,y,z) \leq 5$ mm, $x_{min} \geq 1,5$),
- variant 5 was considered optimal, for the assumed frame structure, the objective function has reached value $m=859$ kg, ($\sigma_{Smax}= 199,2$ MPa, $x_{min}=1,7$, $w_{max}(x,y,z)=4,17$ mm),
- the results of the calculations showed that the maximum permissible load weight should not exceed 15.6 tonnes,
- obtaining lower values ($\sigma_{Smax}=153,9$ MPa, $w_{max}(x,y,z)=3,73$ mm, $x_{min}=2,2$), with a slight increase in the value of $m = 75$ kg of frame weight, was obtained for t variant 4,
- calculations indicate the possibility of further optimization of the structure by changing the material features or changing the model structure at the place of attachment of the rear axle of the wheel set,
- considerable material savings obtained for the optimal variant 5 (about 190 kg) will result in simplification of manufacturing technology, energy savings and reduction of costs during production and operation.

REFERENCES

1. **Branowski B. 1998**, Wprowadzenie do projektowania. Wydawnictwo Naukowe PWN, (in Polish).
2. **Ditrich M.1999**, Podstawy konstrukcji maszyn, t. 1, wyd. III. Wydawnictwa Naukowe-Techniczne, (in Polish).
3. **Dziama A.1985**, Metodyka konstruowania maszyn. Wydawnictwo Naukowe PWN, Polska, (in Polish).
4. **Jaskulski A. 2011**, Autodesk Inventor-metodyka projektowania. Wydawnictwo Naukowe PWN, (in Polish).
5. **Lodwik D., Malesa W. 2014**, An analysis of selected container structures with built-in multi-layer composite sheets with the use of fem. TEKA Kom. Mot. I Eng. Roln. Vol 14. No. 3, (in Polish).
6. **Lodwik D., Jakliński L., Malesa W., [i in.]. 2012**, The test stand calculations of the research station of sub-atmospheric pressure press with implementation of the finite element method. TEKA Kom. Mot. I Eng. Roln., Vol 12. No. 2., (in Polish).
7. **Niezdodziński M., Niezdodziński T. 1996**, Wzory, wykresy i tablice wytrzymałościowe, wyd. VI. Wydawnictwa Naukowe-Techniczne, (in Polish).
8. **Osiński Z. 2012**, Podstawy konstrukcji maszyn, wyd. II. Wydawnictwo Naukowe PWN, (in Polish).
9. **Osiński Z., Wróbel J. 1995**, Teoria konstrukcji. Wydawnictwo Naukowe PWN, (in Polish).
10. **Stasiak F. 2011**: Autodesk Inventor – zbiór ćwiczeń. Wydawnictwo ExpertBooks, Łódź, (in Polish).