

THE PROTOTYPE PROJECT OF THE POSITION TO DESIGNATE THE SCREW THRUSTER LOBE SPECIFIC GRAVITY

Włodzimierz Kończewicz, Mateusz Stępkowski, Marek Skowroński

Gdynia Maritime University, Faculty of Marine Engineering
Morska Street 83, 81-225 Gdynia, Poland
tel.: 058 6901-564

e-mail: wlodek.am@gdynia.pl, mtstepkowski@gmail.com, mskowronski7@gmail.com

Lesław Iwanicki

Rolls-Royce Poland Sp. z o. o.
Kontenerowa Street 8, 81-155 Gdynia, Poland
tel.: +48 587820655, fax: +48 587820656
e-mail: leslaw.iwanicki@rolls-royce.com

Abstract

During the exploitation screw thruster, lobes are being defected in many ways. Sample types of damages are as follow: the material damages caused by cavitation, corrosion, deflection. In order to facilitate and to improve the quality of repairing activities, the idea of make the position to designate screw thruster lobes specific gravity has been initiated by Rolls-Royce Poland Company and Nautica Academic Circle. Incorrect lobes balance influences on irregular work of the screw, which results in the occurrence of adverse effects such as generation of vibration or increasing probability of mechanical elements damages during the exploitation. Screw thruster lobe specific gravity designation helps in identification of areas for treatment (welding, grinding) to achieve the desired parameters. The creation of designate screw thruster lobes specific gravity position gave the possibility of using the innovative scanning in 3D, which shows very clearly the picture of the scanning item. With Scanect and Autodesk Inventor 2014 software, we can manipulate the resulting image. This makes possibility of the lobes gabarits measurement. What is more, it designates the specific gravity exact to 10%. It increases the quality of the lobe renovation and these results in an improvement the screw thruster lobe's work efficiency. The cooperation of The Maritime University in Gdynia and Rolls-Royce Poland Company resulted in creating the prototype, which will be tested by service technics in working circumstances.

Keywords: screw thruster lobes, specific gravity, thruster, position, 3D scanning

1. Introduction

The propeller with a screw thruster is used for driving the ships. Power generated and sent by the main engine converts rotary motion of the screw shaft for vessel's thrust force. The drive is based on the Bernoulli equation and Newton's third law. The pressure difference formed on the front and backside of the blade makes the water is forced out at a higher speed for the blades. The propellers are made of anti-corrosive materials due to their destiny to work in seawater, which is accelerator of corrosion. The materials used for production are aluminum alloys and stainless steel. Other popular blanks are nickel alloys, aluminum and bronze, which are about 10-15% lighter than other materials and are more durable. Basic Characteristics of propellers are diameter of the circle defined by the rotating ends of the blades during rotation, pitch (the distance by which the screw could move during one rotation, if moving in a soft solid) and the angle of attack (the angle of the propeller blade is oriented in relative to the hub). The basic division of propellers refers to the number of patches and distinguishes three-lobe screws (Fig. 1), four-lobes (Fig. 2) and five-lobes (Fig. 3). Another one concerns the stroke of the blade: screw fixed, adjustable and folding.

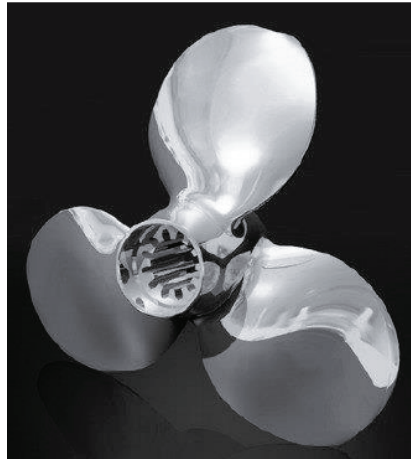

Fig. 1. Three-lobe screw



Fig. 2. Four-lobe screw



Fig . 3. Five-lobes screws

2. Basic requirements

Dimensions and weight of the test stand should not hamper his transport – the position must be mobile and ready to transport in any situation. As the maximum dimensions assumed dimensions of Ford Transit van type jail. One of the key requirements was also a simple service-oriented to be operated by only two technicians. The initial time of completion of the project was three months. The total project budget was set at 1500 euro.

3. Technical assumptions

The main task of test stand was to determine the lobe screw thruster's specific gravity. Besides the most important function had been created an alternative tasks that have influence on innovation positions:

- Define areas for sanding or surfacing and how these tasks affected the displacement of the centre of gravity, based on the determinate centre of gravity,
- Obtaining the image of lobe in three dimensions,
- Ability to suspend the test piece up to 500 kg.

4. Test stand specification

The construction was designed in Autodesk Inventor 2014 (Fig. 4). When the draw was ready strength analysis based on steel profiles St3S combined normalized welds has been made. The analysis confirmed the validity of the selection of material. The project includes steel profiles with the following parameters:

- 40x40x3 mm. St3S steel for execution by the lower structure,
- 30x30x3 mm. St3S steel intended for the upper part of the structure.

The selection of the two profiles of the listed dimensions allowed protrusion of the upper structure relative to the substructure.

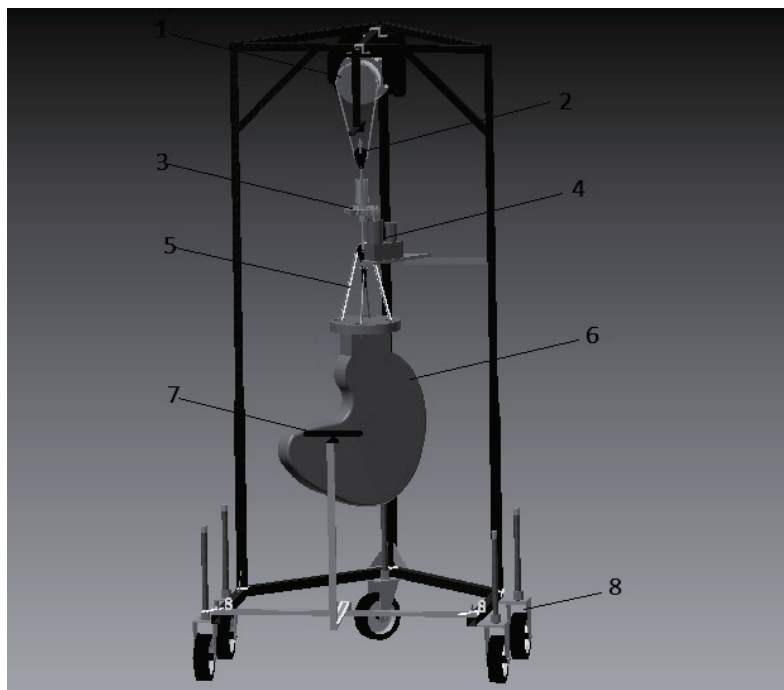

Fig. 4. Measuring position Project where: 1. Winch, 2. Drawn object lock, 3. Transmission, 4. Electric drive, 5. Four cords, 6. Lobe, 7. Kinect (3D scanner), 8. Six Wheels

The next step of the project was to mount the winch, which allows rising and lowering the lobe to the correct height and enable easy installation and dismantling of the object. Due to the maximum weight of the lobe was set to 500 kg. decided to mount a winch with 1800W power and a maximum lifting capacity of 800 kg. In order to facilitate transport and manoeuvrability steel wheels has been mounted.

It was necessary to design a connection with a panel of the winch that allows maintaining the lobe in a stationary position by four cords and subsequent closing two cords together to get the second result. Erected on a call using blocks that allow free stabilization of the lobe. To stabilize

the hanger created blockade, this will be blocked, in the special distorted sleeve. The blockade mounts in above the upper pulley, which is hauling by the winch. (Fig. 5).

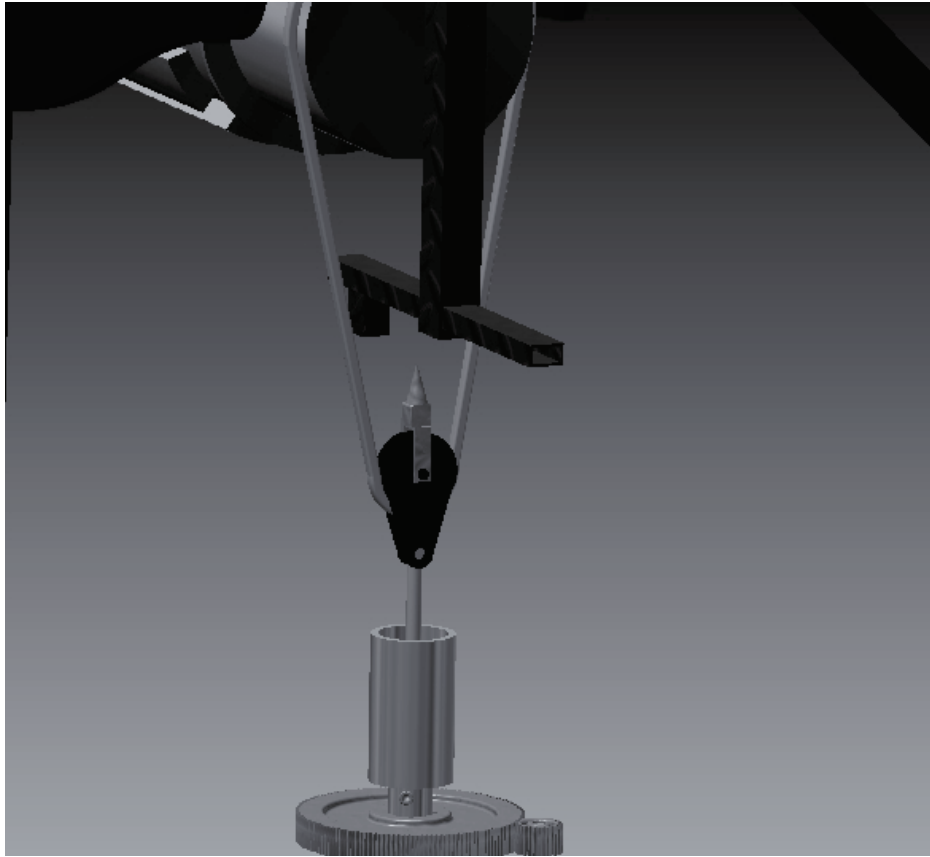

Fig. 5. Drawn object lock

A very important issue was to find a way of transferring the actual image (3D) to computer. The best device for this purpose turned out Kinect of Xbox 360, which has been used as a scanner. To capture and edit any of three-dimensional measurements the following software had to be used:

- Kinect driver for Microsoft Windows,
- a program to capture a 3D image – SKANECT (full version),
- a program for processing and editing 3D image – Autodesk Inventor 2014.

Transmission has been designed for marking the lobe, which increases the accuracy of the scanning. Transmission with an electric motor was necessary due to increasing simplicity of test stand (Fig. 6.). In this case, operator will limit the work to mount the lobe and enable rotation and scanning, which will be stopped after one minute. The next step will be to save the image, shorted together two adjacent cords and restarting rotation with scanning. Gear helps to reduce the rotation to only one revolution per minute. It is necessary to obtain an accurate 3D scan. This, in turn, is important because the higher the accuracy the more accurately we can determine specific gravity of the test object.

5. Measurement method

Gravity centre of element or system of elements is the point where is applied resultant force of gravity of the body. If the particular object is located in homogeneous gravity field then the centre of gravity and the centre of mass converge at the same point. Hanging lobe on four strings mounted on the same block stabilizes its position. Obtaining a precise 3D image is possible thanks

to Skanect and Kinect Device. With Autodesk Inventor 2014 perpendicular from the point of the cone-interlocking sleeve to the ground must be drawn. Next shorting together two adjacent strings will change the position of the object which allows obtaining a modified (relative to the first) image 3D. Based on from the same point as in the first case it second perpendicular should be drawn. The centre of gravity is located somewhere on these perpendiculars due to the fact that the lobe stabilizes its position on the loose blocks. Rotating the second image together with determined line in order mutually overlap two lobes, with each other will result with the intersection of both lines. This point is the centre of gravity of the object (Fig. 7).

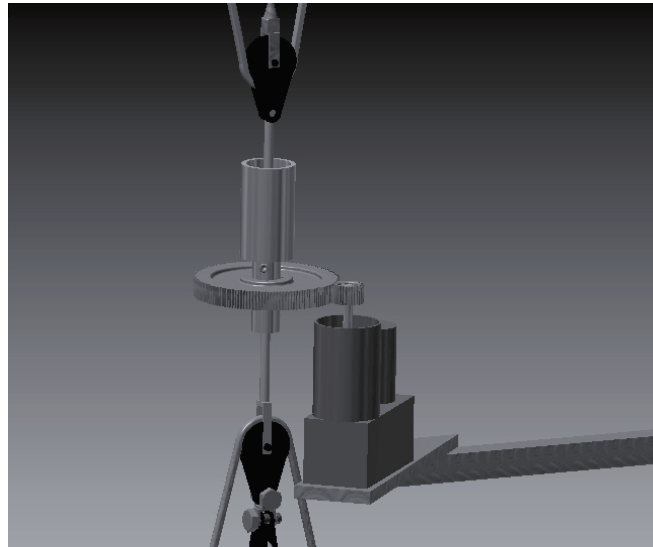

Fig. 6. Transmission

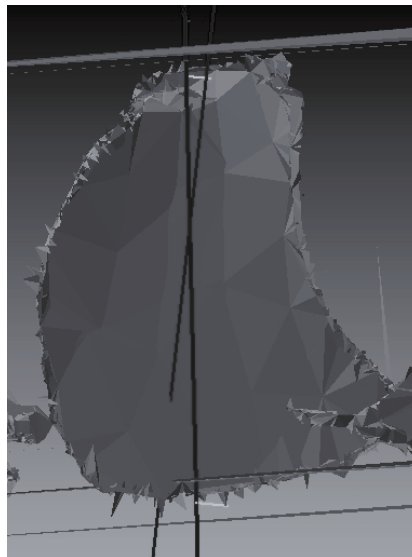

Fig. 7. The first measurement result

6. Summary

Objective of the project was the graphical possibility of designation element's specific gravity with maximum weight 500 kg. To perform the construction used steel profiles and wheels designed to work in heavy load. Moreover used the wire rope winch and the electrically driven transmission to rotate the lobe. Skanect is the software enabling scanning and then save it in a file format that allows the later treatment. To edition applied the Autodesk Inventor 2014 software.

The final designate of screw thruster lobe's specific gravity, with maximum difference 5-10% leads to more precise definition of treatment. It increases the quality of the lobe renovation. It results in improvement the screw thruster lobe's work efficiency.

References

- [1] Iwanicki, L., Ciecierski M., *Stery strumieniowe*, unpublished.
- [2] Kozak, B., *Mechanika Techniczna. Podręcznik*, published by WSiP, 2008.
- [3] Wiśniewski, S., *Termodynamika Techniczna*, published by WNT, 2012.
- [4] Rolls-Royce Sp. z o.o. documentation.