

## Use of state-of-the-art jigs of KOMAG type for a beneficiation of coking coal

Published online: 31-03-2020

Piotr Matusiak<sup>1a</sup>, Daniel Kowol<sup>1</sup>

<sup>1</sup> KOMAG Institute of Mining Technology, Pszczyńska 37, 44-101 Gliwice, Poland

<sup>a</sup> e-mail: pmatusiak@komag.eu

Keywords: coal mining, mechanical processing, pulsatory jig, jig beneficiation node

Słowa kluczowe: górnictwo, przeróbka mechaniczna, osadzarka pulsacyjna, węzeł wzbogacania osadzarkowego

Abstract:

The present beneficiation technology, used in the Mechanical Coal Preparation Plant at the Budryk Mine is assessed in the article. A description and a schematic diagram of the beneficiation node before its modernization are inserted. The industrial test results of pulsatory, medium-size-grain jigs are presented. The modernization scope of the jig node with use of new pulsatory jigs of KOMAG type is described and a new technological scheme is discussed. The effects of implementing new beneficiation systems in the modernized plant are given.

Streszczenie:

W artykule oceniono dotychczasową technologię wzbogacania stosowaną w zakładzie przeróbki mechanicznej węgla w KWK „Budryk”. Zamieszczono opis i schemat osadzarkowego węzła wzbogacania przed jego modernizacją. Przedstawiono wyniki przemysłowych badań osadzarek pulsacyjnych średnioziarnowych. Omówiono zakres modernizacji węzła osadzarkowego z zastosowaniem nowych osadzarek pulsacyjnych typu KOMAG, przedstawiono nowy schemat technologiczny. Omówiono efekty wdrożenia nowych systemów wzbogacania w zmodernizowanym zakładzie. **(Zastosowanie nowoczesnych osadzarek typu KOMAG do wzbogacania węgla koksowego)**

### 1. Introduction

For several dozen years the KOMAG Institute of Mining Technology has been designing jigs for a beneficiation of different grain classes: OM-fines jigs for grain sizes 20-0(0.5) mm, OS-medium-size-grain jigs for grain sizes 80(50)-0(0.5) mm and OZ- grain jigs for grains 120-20 mm.

Their construction is modernized permanently starting from the mechanisms generating a pulsatory motion, through the kind and way of fixing sieve decks, the shape of pulsatory chambers and ending with the ways of collecting beneficiation products [1,2,3,4,5]:

Research work, concerning gravitational beneficiation with particular attention paid to pulsatory jigs, is also conducted and it enables to improve their operation permanently, both in the scope of beneficiation efficiency as well as reliability [6,7,8,9].

Highly productive and precise control of the raw material supply, of shaping the pulsatory motion and of collecting the beneficiation product is ensured by the SSWO KOGA control system of the jig node, developed at the KOMAG Institute [10,11,12,13,14].

A modernization of the jig node in the Mechanical Coal Preparation Plant at the Budryk Mine for a beneficiation of coking coal, with use of new pulsatory jigs of KOMAG type, is presented in the article.

### 2. Technology of jig beneficiation – condition before modernization

Mechanical Coal Preparation Plant at the Budryk Mine had three pulsatory jigs for a beneficiation of coal feed, including two double-trough OS36D3E jigs and one single-trough OM24L4E jig [15,16].

Initially, all the jigs were equipped with the SSO electronic control system made by the BGG Automation Plant. In recent years, before the modernization started, the BGG control systems were gradually replaced by the KOGA system developed at the KOMAG Institute [17,18,19].

The material of grain sizes 60(80)-12(0) mm, obtained in the results of a classification on four PWE1-2,6x6 screens, was fed to the OS36D3E jig (Fig.1). The bottom product could be directed to the raw fines tank, energy mix tank or to dumps.



**Fig. 1.** OS26D3E medium-size-grain jig

The screen top product, was delivered to the OS36D3E jigs through the area sieves, playing a role of a navigable trough, in the area of which the top water sprays were installed.

A characteristic feature of the above mentioned equipment is a supply of both working troughs with pulsating air through common air collectors.

The jigs were equipped with key culverts of the “heavy” product. The culverts of this type, in contradistinction to the solutions used in fines jigs, do not possess a collecting channel and the heavy material is collected from the working chamber through a slot situated on the level close to the surface of sieves in the working trough.

Each of the above mentioned jigs, used for a three- product beneficiation, had three bucket conveyors, from which two were used for dewatering of waste product (one for each trough) and one conveyor – for dewatering of intermediate product. The waste product, after its dewatering in bucket conveyors, was directed to the collecting belt.

The intermediate product, after its dewatering in a bucket conveyor, was directed to the PWP1-2.6x5.25 screen equipped with sieves of  $\varnothing 10$  mm mesh. The top product, after having been crushed in the UP 1500x1000 crusher, combined with the bottom product of the above mentioned screen, was the feed to the OM24L4E jig. The concentrate product was directed to preliminary dewatering and a classification on the PWP1 2.6x4.65 screen, equipped with the sieves of  $\varnothing 20$  mm mesh. The bottom product of the screen was subject to dewatering on the BISO 2800 sieves and WOW 1.3 vibratory drainers.

In turn the screen top product, after having been crushed in the UP 1500x1000 crusher, could be combined with the products of centrifuges under dewatering or become a separate commercial product.

The OM24L4E jig was used for a secondary beneficiation of the crushed intermediate product obtained from the OS36D3E.

The waste product, from the first two compartments, after having been dewatered in the bucket conveyor, was directed to a collecting belt conveyor.

The “heavy” product of the last jig compartment, after its dewatering in the bucket conveyor, could be combined with the concentrate product or directed for a generation of energy mixes.

The concentrate product was subject to a two-stage dewatering on the OSO 2400 sieve and on two WOW 1.3 drainers.

A simplified scheme of the jig beneficiation node at the Budryk Mine before the Plant modernization is presented in Fig.2.

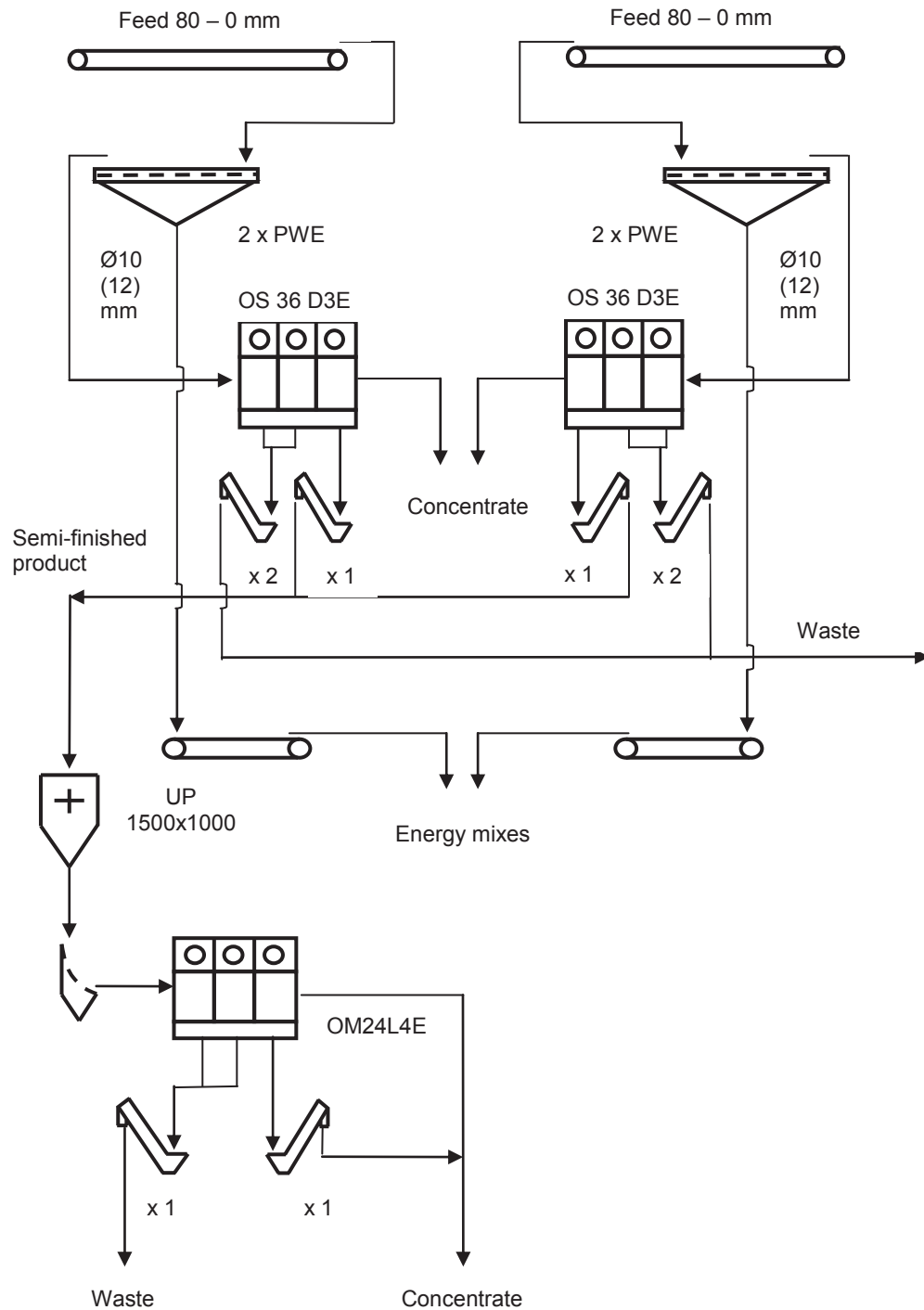

**Fig. 2.** Simplified scheme of the jig beneficiation node at the Budryk Mine before its modernization

### 3. Industrial tests of OS36D3E pulsatory, medium-size-grain jigs

One of the essential issues in the jig beneficiation process is dynamics of shaping density layers of the material under beneficiation (bed) in the jig working trough and its impact on the beneficiation process effectiveness [20,21].

The tests in this scope were conducted in the OS36D3E medium-size-grain pulsatory jig, installed at the Budryk Mine, used for a three-product beneficiation of material in the grain class 60(80)-12(0) mm. Within the framework of tests point samples of the jig bed, embracing the whole bed layer, were taken. These samples were taken in the first and second parts of each jig compartment in three layers which were next subject to density analysis in heavy liquids of density  $1.5 \text{ g/cm}^3$  and  $1.8 \text{ g/cm}^3$ .

In Table 1 the analysis results of the layer adjacent to the sieve in individual working compartments are listed.

**Table 1.** Parameters of the layer adjacent to the sieve in the jig working compartments

Fraction density, $\text{g/cm}^3$	Compartment I, %		Compartment II, %		Compartment III, %	
	Part I	Part II	Part I	Part II	Part I	Part II
> 1.5	99.0	93.9	93.4	88.2	98.5	89.4
> 1.8	96.0	86.9	89.0	75.1	88.3	69.5
1.5 – 1.8	3.0	7.0	4.4	13.1	10.2	19.9

The analysis of test results showed that in the following jig compartments, which were characterized by higher and higher threshold and heights of the layer adjacent to the sieve, an increase in the layer parameters' differences occurred.

On the contrary to a uniform gravimetric composition of the layers adjacent to the sieve in Part I of the compartment, in Part II (in which measurement points were situated close to the separation/collection sphere) the output of fraction  $>1.5 \text{ g/cm}^3$  and  $>1.8 \text{ g/cm}^3$  was significantly smaller.

During these tests the measurements of the bed density distribution, using experimental floats together with recording a location of the bottom product culvert, were taken. The test results are listed in Table 2.

A comparison of boundary densities of floats in the I and II waste compartments, whose exceeding caused their falling down towards the collecting slot, showed that the float density in Compartment I was smaller than in Compartment II despite collecting bigger and heavier grains.

Twice bigger height of the threshold in Compartment II, on the contrary to Compartment I limited the effect of "sucking in" the grains by the culvert collecting slot.

The effect, mentioned above, resulted among others from a specificity of key culverts construction used in the jigs under testing.

The conditions occurring in Compartment I required a quick reaction of control systems to bigger changes in location of the layer under separation to maintain a stable waste product as regards its quality.

**Table 2.** List of recorded parameters for the following jig compartments

Float	Compartment I, %	Compartment II, %	Compartment III, %
Limiting density, $\text{g/cm}^3$	1.525	1.825	1.425
Height (H) of separating layer, cm	42.30	33.40	27.50
Culvert	Compartment I, %	Compartment II, %	Compartment III, %
Mean opening, %	55.6	44.7	34.0
Scope of changes, %	71.1	24.2	25.9
Frequency of changes, pulsation cycles	12.0	25-50	20.0

A design solution of key culverts and of pulsatory chambers, used in the OS36D3E jig under testing, caused that the amount of collected heavy product was dependent on both the opening size of the culvert slot as well as on the intensity of pulsating water stream flowing through the slot. An impact of the second factor was the bigger, the smaller the threshold height. In this case a partial loss of control over an operation of collecting the heavy product was experienced, which could cause losses of combustible substance (coal) in the waste product.

Basing on the test results, it can be stated that it is purposeful to limit the water flow through the culvert to obtain a control increase over an operation of collecting the heavy product and in effect to increase a separation effectiveness. For the grain scope under beneficiation, it can be realized due to an application of a new design solution of the culvert for heavy products.

It is required to ensure a uniform distribution of working air in the pulsatory chambers through an application of independent feeding of jig's working troughs to increase stability of water flow in a pulsatory motion.

Besides, violent density changes, which forced a quick reaction of control systems, were demonstrated.

#### **4. Modernization of jig beneficiation node at the Mechanical Coal Preparation Plant at the Budryk Mine**

##### **4.1 OS18 medium-size-grain jigs**

In the framework of the modernization two OS36D3E double-trough jigs, used hitherto, were exchanged for six OS18 single-trough medium-size-grain jigs of KOMAG type. The rated capacity of each jig, having the working surface of 18 m<sup>2</sup>, was determined on the level of 250 t/h [15].

New, three-compartment jigs were designed for a beneficiation of the feed in grain class 80-0.5 mm and its separation into three products: concentrate, semi-product and waste.

Dewatering of beneficiation products is conducted in the way used hitherto, i.e. the concentrate product – on screens, and then the bottom product – on the OSO sieves and vibratory centrifuges, however the semi-product and the waste product – in bucket conveyors.

The pulsatory motion in the jig is generated by pneumatically controlled disk valves and an application of electronically controlled pulsation cycle, using working air supply at the pressure of 0.03-0.035 MPa and its consumption up to 110 m<sup>3</sup>/min.

A consumption of bottom water is assessed at 600 m<sup>3</sup>/h (with a possibility of its control) at the pressure of 1-1.2 bar.

The collecting system of heavy products (waste, semi-products), made of stainless steel, is hydraulically supplied at the installation required pressure on the level of 50 bar.

A new design solution of the product culvert of a damper type, was implemented in the OS18 medium-size grain jigs.

The OS18 medium-size grain jig of KOMAG type is presented in Fig. 3.

Ten bucket conveyors (Fig.4) of bucket width equal to 1000 mm were installed in the modernized jig node.

Six of them were planned for dewatering of waste products and four – for dewatering of semi-products.

The length of conveyors for dewatering waste products was 18 m, at the inclination angle of 60°. In the case of the conveyors for dewatering of the semi-product their length was 20 m, at the inclination of 65°.

The capacity of the installed bucket conveyors, both for the waste and the semi-products was 220 t/h at the power of the main driving motor equal to 30 kW.

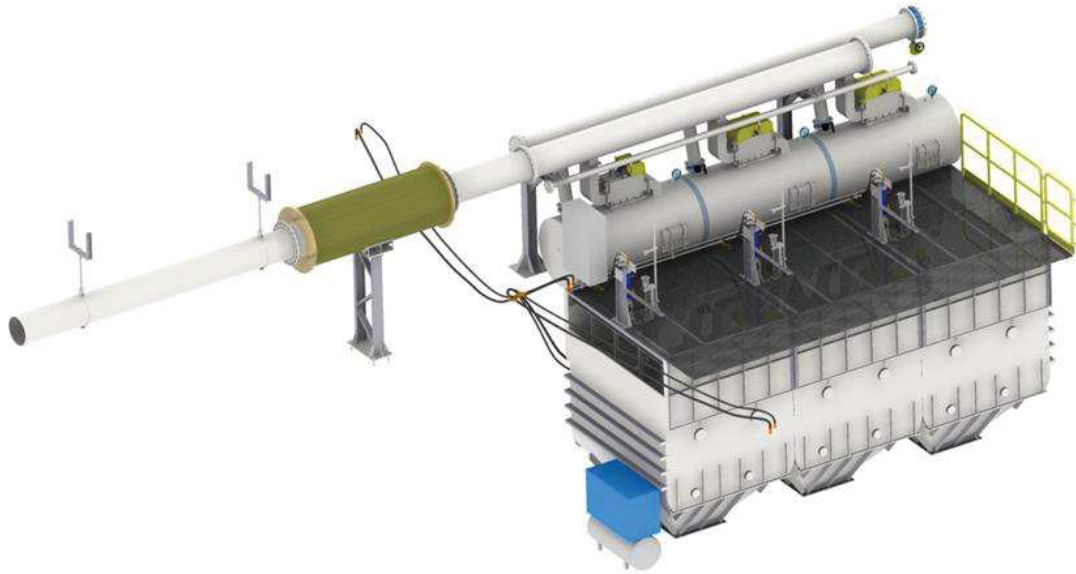

Fig. 3. OS18 medium-size grain jig of KOMAG type

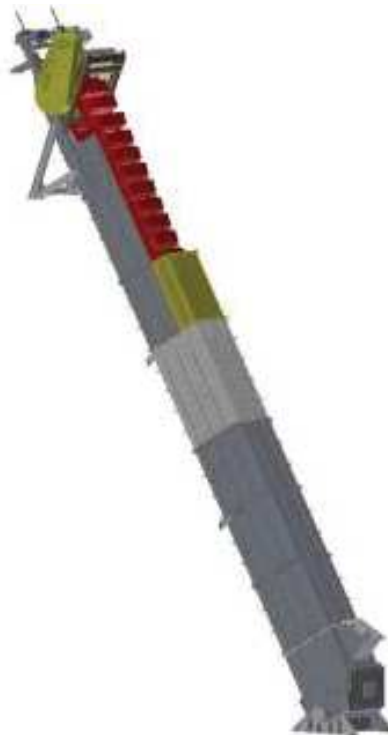

Fig. 4. B-1000 bucket conveyor

#### 4.2 OM20 fines jigs

The modernized node of fines feed jig beneficiation is composed of two secondary, single-trough OM20 fines jigs of KOMAG type. The rated capacity of each jig, of the working surface equal to 20 m<sup>2</sup>, was determined to be 250 t/h [16].

One of the OM20 jigs was installed in the place, where the OM24L4E jig used to be operated. The other one was located in the place of the FTC vacuum filters used so far for dewatering of the flotation concentrate. At present their role was taken over by sedimentation-sieve centrifuges.

New three-compartment jigs are used for a beneficiation of the feed in the grain class 12-0 mm and its separation into three products: concentrate, semi-product and waste. The semi-product from

new OS medium-size-grain jigs, crushed below 12 mm on the UPK 1500x1000 crushers, will be the feed, similarly as in the system before modernization.

Dewatering of beneficiation products is conducted in the same way as it has been done so far, i.e. the concentrate product – on OSO sieves and vibratory centrifuges, however the semi-product and waste product – in bucket conveyors.

The pulsatory motion in the jig is generated with use of pneumatically controlled disk valves and an application of electronically controlled pulsation cycle, using the working pressure supply of 0.03 MPa pressure and at its consumption up to 100 m<sup>3</sup>/min.

A consumption of bottom water is assessed for 450 m<sup>3</sup>/h (with a possibility of its control) at the pressure of 1-1.2 bar.

A system of heavy products collection (waste, semi-products), made of stainless steel, is hydraulically supplied at the required installation pressure of 50 bar.

The OM20 fines jig is presented in Fig.5

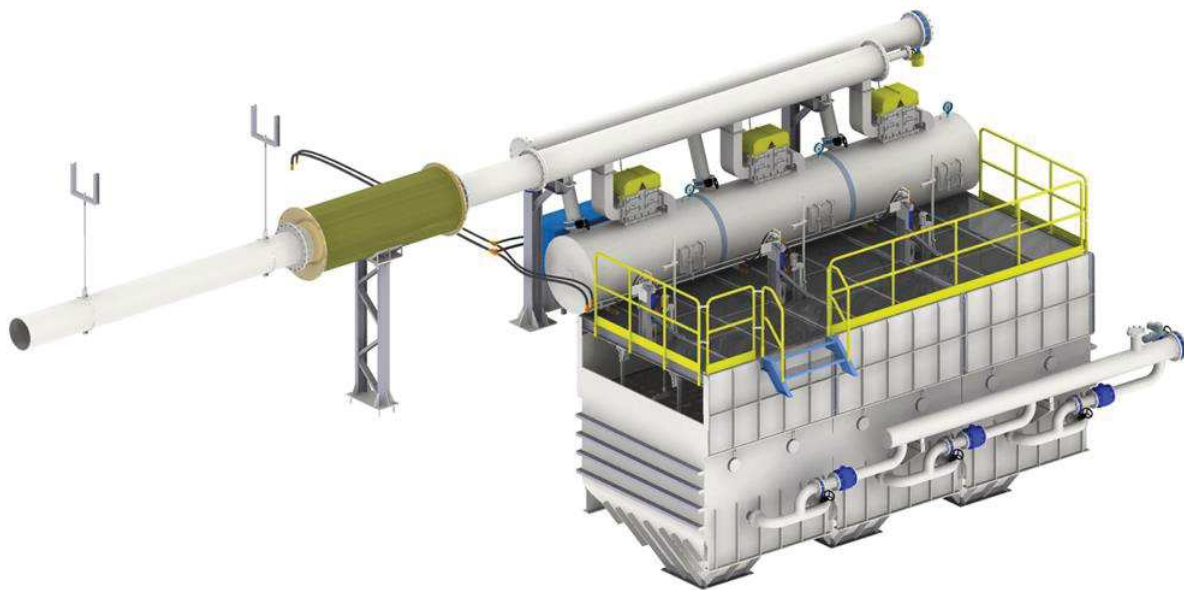

**Fig. 5.** OM20 fines secondary jig of KOMAG type

In the modernized jig node four bucket conveyors are used-two of them for one OM20 jig. The width of the buckets is 1000 mm.

Each jig is equipped with one conveyor for dewatering of the waste product and one-for dewatering of the semi-product.

The length of the conveyors for dewatering of the waste products is 21.5 m, at the inclination angle of 62°. In the case of the conveyors for dewatering of the semi-product their length is 19 m, at the inclination of 71°.

The capacity of the bucket conveyors both for the waste and for the semi-product is 220 t/h at the main drive motor power equal to 30 kW

### 4.3 Modernized jig beneficiation node

The modernized jig beneficiation node (Fig.6 and 7) was designed in 2017 and a start-up of the first system took place in 2018.

It consists of:

- 6 OS18 medium-size-grain jigs (L and R) (80-0.5 mm),
- 2 OM20 fines jig (12-0 mm),
- 14 B-1000 buckets conveyors.

The modernized node consists of two systems for beneficiating the medium-size-grain feed, which gives a possibility of independent beneficiation of different types of coal (types: 34 and 35) in each of the above mentioned systems. Both systems are composed of three OS18 jigs.

Several new design solutions are implemented in the jigs to increase a control of the beneficiation process and to increase an effectiveness of the beneficiated material separation. New medium-size-grain jigs were designed as single-trough units with independent control, feed and media (water, air) supply. This solution enables to increase a control and a stabilization of the pulsatory motion parameters, being a factor which, to a big extent, decides about beneficiation effectiveness.

The applied culverts of damper type for heavy products increase a control in the collecting zone and a stabilization of the products collecting operation. A secondary beneficiation in the OM20 jigs of the parting material from the medium-size-grain jigs, crushed in the UPK 1500x1000 crushers below 12 mm, enables to maximize production rates.

The jig beneficiation nodes, installed at the Budryk Mine are equipped with the authors' KOGA control system. It is constructed on the base of a free-programmable controller which ensures monitoring of operation and a control of the jig node operational correctness, automatic, emergency switch-off and remote, manual, sequence stop and start of the jig and of the devices operating together with it.

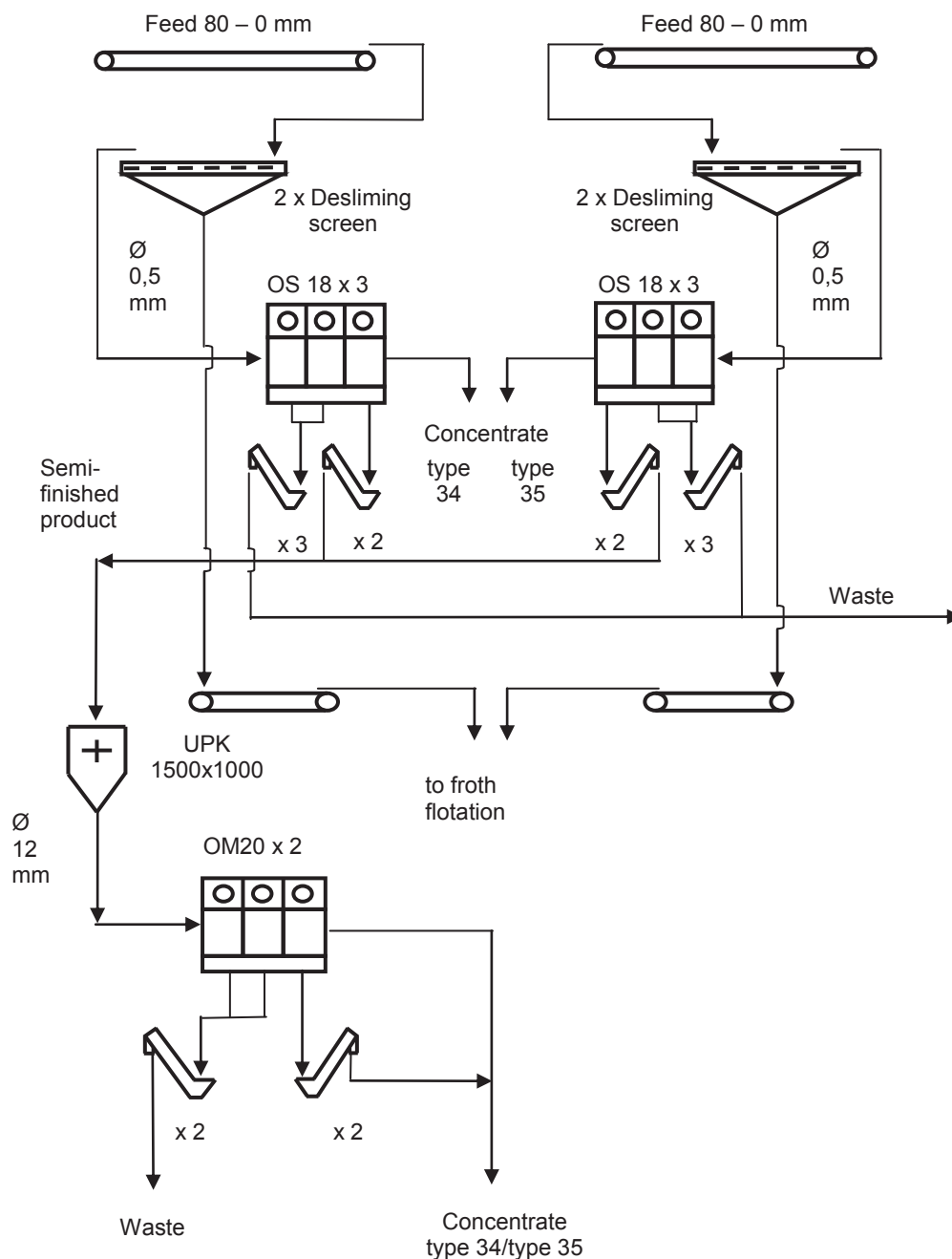

Fig. 6. Simplified scheme of the jig beneficiation node at the Budryk Mine after modernization



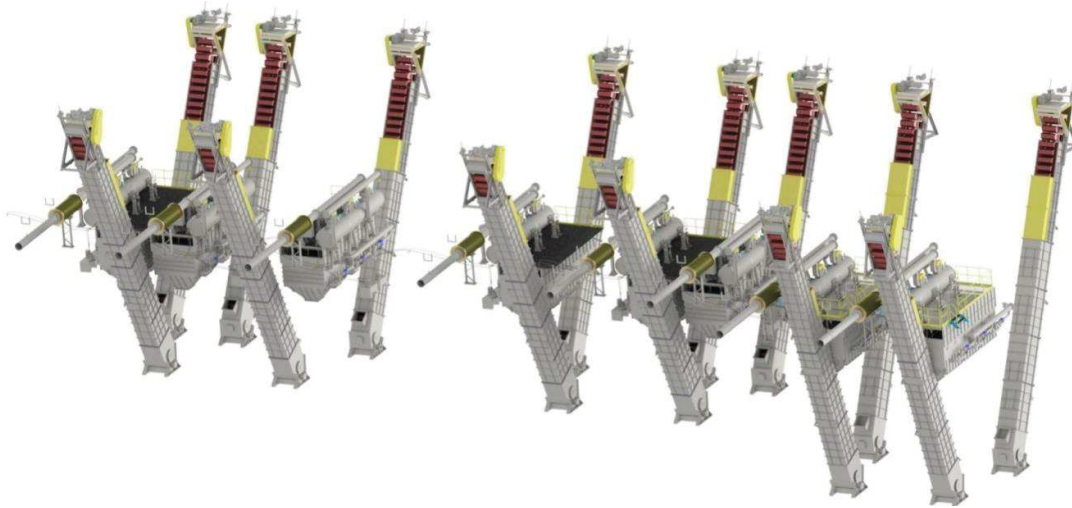

Fig. 7. Beneficiation node at the Budryk Mine after modernization

## 5. Summary

The results of technological tests, conducted by the KOMAG specialists in the Mechanical Coal Preparation Plant of the Budryk Mine in 2011, indicated a necessity of introducing technological and design changes of the beneficiation node to improve parameters of beneficiation products. Within the framework of the plant modernization, basing on the design project elaborated at the KOMAG Institute of Mining Technology, six OS18 medium-size-grain jigs and two OM20 fines jigs together with dewatering bucket conveyors in the number of fourteen, were installed. The jigs were equipped with the innovative KOGA control system developed at the KOMAG Institute.

The solution implemented in the medium-size-grain beneficiation node, consisting in a division of the jigs into two systems (three jigs in each of them), enabled a simultaneous, independent beneficiation of coal (types:34 and 35) or an operation of only one system.

An implementation of new design solutions in the modernized beneficiation node enables a more effective realization of the beneficiation process and it enables to maximize a production of high-quality coal concentrates.

An additional factor, maximizing the process capacity, is a recovery of coal grains from the parting product being beneficiated in the secondary OM20 fines jigs.

## References

- [1] Matusiak P., Kowol D.: Możliwości poprawy parametrów jakościowych i ilościowych produktów w węźle wzbogacania osadzarkowego. In: *Innowacyjne i przyjazne dla środowiska techniki i technologie przeróbki surowców mineralnych. Bezpieczeństwo - Jakość – Efektywność*. KOMEKO 2012. Instytut Techniki Górniczej KOMAG, Gliwice 2012 s. 115-124. ISBN 978-83-60708-59-0
- [2] Matusiak P., Kowol D.: Maszyny do przeróbki mechanicznej konstruowane w ITG KOMAG. *Masz. Gór.* 2013 nr 2 s. 71-76
- [3] Matusiak P., Kowol D., Łagódka M.: Nowe wdrożenia wzbogacalników pulsacyjnych typu KOMAG., In: *Innowacyjne i przyjazne dla środowiska techniki i technologie przeróbki surowców mineralnych. Bezpieczeństwo - Jakość – Efektywność*. KOMEKO 2016, Instytut Techniki Górniczej KOMAG, Gliwice 2016 s. 175-189; ISBN 978-83-60708-91-0.
- [4] Matusiak P., Kowol D.: Rozwój osadzarek pulsacyjnych typu KOMAG. *Masz. Gór.* 2018 nr 2 s. 40-52.
- [5] Matusiak P., Kowol D.: State-of-the-art pulsating jigs of KOMAG type. In: *IMTech 2019, Innovative Mining Technologies, Scientific and Technical Conference, Szczyrk, Poland, 25-27 March 2019* s. 1-10, (IOP Conference Series: Materials Science and Engineering 2019 vol. 545) ISSN 1757-899X.
- [6] Kowol D., Lenartowicz M., Łagódka M.: Badania laboratoryjne wpływu parametrów pokładu sitowego na rozdział materiału w osadzarku pulsacyjnej w zależności od charakterystyki nadawy. *Maszyny Górnicze* 1/2010 (121).

- [7] Kowol D., Łagódka M., Matusiak P.: Badania możliwości zastosowania trapezoidalnego cyklu pulsacji wody dla osadzarkowego wzbogacania nadaw średnioziarnowych w klasie 60-0,5 mm. *Masz. Gór.* 2016 nr 2 s. 33-42.
- [8] Kowol D., Matusiak P., Łagódka M.: Możliwości zwiększenia efektywności procesu produkcji miałów węgla koksowych poprzez wzrost dokładności wtórnego wzbogacania półproduktu w osadzarce pulsacyjnej. *Masz. Gór.* 2018 nr 2 s. 53-64.
- [9] Kowol D., Matusiak P.: Improving the quality of hard coal products using the state-of-the-art KOMAG solutions in a pulsating jig nod. In: *IOP Conference Series: Materials Science and Engineering, Volume 641, Mineral Engineering Conference (MEC 2019) 16–19 September 2019, Kocierz, Beskid Mały, Poland.*
- [10] Król J., Krzak Ł., Jendrysik S., Stankiewicz K., Woszczyński M.: Wdrożenie układu sterowania węzłem osadzarkowym w KWK "Sośnica". In: *Innowacyjne i przyjazne dla środowiska techniki i technologie przeróbki surowców mineralnych. Bezpieczeństwo - Jakość - Efektywność KOMEKO 2016, Instytut Techniki Górniczej KOMAG, Gliwice 2016 s. 227-237; ISBN 978-83-60708-91*
- [11] Jendrysik S., Stankiewicz K., Jasiulek D.: Innowacyjne rozwiązania ITG KOMAG w zakresie automatyzacji węzłów osadzarkowych. *Masz. Gór.* 2018 nr 2 s. 65-77.
- [12] Jendrysik S., Kost G.: Control of bucket conveyor's output. *Mechatronics 2017 - Ideas for Industrial Applications, Editors: Jerzy Świder, Sławomir Kciuk, Maciej Trojnacki, Advances in Intelligent Systems and Computing 934, Springer Nature Switzerland AG 2019 s. 192-200, ISBN 978-3-030-15857-6; ISSN 2194-5365.*
- [13] Jendrysik S., Jasiulek D., Stankiewicz K., Babczyński J.: Implementation of a jig control system at BUDRYK Coal Mine. *IOP Conference Series: Materials Science and Engineering, Volume 679, 2019.*
- [14] Rogala-Rojek J., Stankiewicz K., Jendrysik J.: SCADA class software of the KOGA control system of jig beneficiation node. *IOP Conference Series: Materials Science and Engineering, Volume 545, Innovative Mining Technologies IMTech 2019 Scientific and Technical Conference 25–27 March 2019, Szczyrk, Poland,*
- [15] Matusiak P., Kowol D., Łagódka M.: Opracowanie koncepcji osadzarki średnioziarnowej OS wraz z urządzeniami współpracującymi na przykładzie wytypowanego zakładu przerobczego, ITG KOMAG 2013, (unpublished).
- [16] Matusiak P., Kowol D., Łagódka M.: Opracowanie koncepcji osadzarki miałowej OM wraz z urządzeniami współpracującymi na przykładzie wytypowanego zakładu przerobczego, ITG KOMAG 2013, (unpublished).
- [17] Gawliński A., Jendrysik S., Kowol D., Rogala-Rojek J., Stankiewicz K., Woszczyński M.: Doświadczenia z badań i wdrożenia systemu sterowania osadzarką pulsacyjną OS36 w KWK Budryk. In: *Innowacyjne i przyjazne dla środowiska techniki i technologie przeróbki surowców mineralnych. Bezpieczeństwo - Jakość - Efektywność. KOMEKO 2011, Instytut Techniki Górniczej KOMAG, Gliwice 2011 s. 137-144. ISBN 978-83-60708-47-7*
- [18] Gawliński A., Jasiulek D., Jendrysik S., Kowol D., Łagódka M., Rogala-Rojek J., Stankiewicz K., Woszczyński M.: System sterowania osadzarką pulsacyjną KOMAG. *Masz. Gór.* 2011 nr 2 s. 26-31.
- [19] Jendrysik S., Woszczyński M., Stankiewicz K., Gawliński A.: Układ sterowania węzłem osadzarkowym. In: *Innowacyjne i przyjazne dla środowiska techniki i technologie przeróbki surowców mineralnych. Bezpieczeństwo - Jakość - Efektywność. KOMEKO 2013, Instytut Techniki Górniczej KOMAG, Gliwice 2013 s. 179-187; ISBN 978-83-60708-71-2.*
- [20] Kowol D., Łagódka M.: Badania rozkładu gęstościowego wzbogacanego materiału w strefie rozdziału/odbioru osadzarki pulsacyjnej. In: *Innowacyjne i przyjazne dla środowiska techniki i technologie przeróbki surowców mineralnych. Bezpieczeństwo - Jakość - Efektywność. KOMEKO 2012, Instytut Techniki Górniczej KOMAG, Gliwice 2012 s. 125-137. ISBN 978-83-60708-59-0.*
- [21] Kowol D.: Badania dynamiki kształtowania się warstw gęstościowych w osadzarce przemysłowej. *Masz. Gór.* 2012 nr 1 s. 32-37.