

NEW DESIGNS OF CENTRIFUGAL MAGNETIC FLUID SEALS FOR ROTATING SHAFTS IN MARINE TECHNOLOGY

Leszek Matuszewski
Gdansk University of Technology, Poland

ABSTRACT

The centrifugal magnetic fluid seals have important advantage over the conventional centrifugal seals. They maintain very good sealing capacity at static, medium and high speeds of shaft rotation, with the increased seal lifetime, and minimum torque and static friction. These seals are particularly useful in cases when the angular shaft velocity varies and sometimes decreases to nearly or exactly zero, such as in flywheel applications, ship propeller main shafts, etc. Unique properties of the magnetic fluid give rare opportunities for application in marine design, where perfect sealing together with reliable lubrication are required.

The paper presents a typical design and operation principle of a centrifugal magnetic fluid shaft seal, along with new design solutions. Not only in ocean technology and underwater robotics. Some cases of application of centrifugal magnetic fluid seals in modern sealing technology are included.

Keywords: magnetic fluids, ferrofluids, lubricants, magnetic seals, static seals, rotational seals

INTRODUCTION

At present, magnetic fluid seals are the most important industrial application of magnetic fluid (Ferro fluid) technology. The sealing technique making use of magnetic fluids offers good solutions to many difficult sealing problems in modern machinery and processing equipment, especially in gas and vacuum applications for high-speed rotating shafts [1–2]. Centrifugal magnetic fluid seals belong to a special type of seals and are used in a wide range of rotational shaft speeds, e.g. in rotary pumps, compressors, generators, and in flywheel applications [10–15]. In medicine, shaft seals for rotary blood pumps with low friction requirements are critical for micro leakage and long-lasting usage. Magnetic fluid seals seem perspective for these applications with their zero leakage, no wear, and constant density and viscosity properties [1–4]. A magnetic fluid sealing system can work together with magnetic bearings in one hybrid device being a common seal and bearing kit. Non-contact bearings are expected to give a long life without wear either [3–9].

Many researchers have attempted to apply magnetic bearings and fluid sealing to centrifugal blood pumps [24–26]. However, a totally passive magnetic bearing is not possible and thus at least one degree of freedom must be compensated by an active magnetic bearing. Then, the magnetic bearings need actuators with displacement sensors for stable operation, which increases the system complexity and consumed power. In addition, the bearing stiffness in the radial and axial directions is low for actual use in rotary blood pumps [27]. For small devices, the compromise is an axial diamond settle, which allows replacement of actuators and sensors.

Recently, magnetic fluid seals have been investigated for rotary pumps of various body fluids e.g. blood, lymph, etc., as another promising application for the shaft seal. Magnetic fluid seals were developed in the 1960s in devices controlling the rocket fuel flow, and their use has been extended to various other applications [28, 49–54]. These seals work without rubbing contact of the rotating shaft surface, and hence, there is no wear. Magnetic fluid bridges are covering a gap around the shaft and perfectly block the leakage, while still allowing the shaft to

rotate with relatively small viscous frictional loss [43–46]. In addition, the seal does not require as high-precision matching as mechanical seals. Therefore, developing a clinically proven magnetic fluid seal is extremely valuable for rotary lymph and blood pumps. Mitamura et al. [6, 31–43] developed a magnetic fluid seal with a shield mechanism. The objective of installing the shield is to minimize contact between the sealed liquid and the magnetic fluid seal. The gap between the shield and the shaft was set to 50 μm , which is the same as that between the pole piece and the shaft. The authors installed the seal system in an axial-flow pump and investigated its performance. However, the effect of contact with body liquids upon the performance of the magnetic fluid seals was not investigated. Further investigations of the seal performance during acceleration tests [47–52] have proved that the radial clearance between the pole piece and the shaft can be up to 400 μm , i.e. is much larger than the conventional setting (50 μm).

The conventional centrifugal seals employ the centrifugal forces generated at high rotary speeds to retain the sealing fluid. They work satisfactorily at high shaft speeds, while at lower speeds the sealing fluid is not kept in place and in the static condition the seal does not support any pressure at all. Other difficulties associated with conventional centrifugal seals include problems related to fluid leakage, limited lifetime due to the wear of elastomer seal, high torque, and high static friction, which result from the use of elastomeric auxiliary seals [56–59].

A centrifugal magnetic fluid seal is a completely hermetic shaft seal at static, low- and high-speed modes, with the increased seal lifetime, and the minimum torque and static friction. Patented applications are indicated in the article with their particular numbers and listed in Bibliography.

PRINCIPLE OF OPERATION

A schematic of the centrifugal magnetic fluid seal (CMFS) is shown in Fig. 1. The magnetic flux loops, which are drawn as dotted lines, are created by: a permanent magnet, a pair of

magnet covers with several concentric projections and grooves, a pair of annular rings, a sleeve, and the magnetic fluid injected into the gap. The covers protecting the magnet, the annular rings, and the sleeve are made of ferromagnetic materials.

The magnetic fluid entrapped in the gap carries the force generated by the pressure difference across the seal by means of magnetic attraction at a low shaft rotating speed or at rest, and by the centrifugal force at a higher rotating speed. The CMFS can operate without any contact between rotating and fixed parts even under large rotating vibration, because the gap ΔR in this seal can be kept very large. In addition, the CMFS differs from ordinary centrifugal seals in that it can store the sealing fluid in the gap even when the shaft is at rest.

The sealing pressure p_m generated by the magnetic attraction on each stage can be expressed by the following equation:

$$P_m = \frac{2 \mu_0 M^* H^* w}{\delta} \quad (1)$$

where:

- μ_0 – magnetic permeability of vacuum,
- M – intensity of magnetization,
- H – magnetic field intensity,
- w – width of one stage,
- δ – sealing gap.

The sealing pressure p_c caused by the centrifugal force due to one stage can be expressed as:

$$P_c = r^* \omega^2 \rho^* w \quad (2)$$

where:

- r – radial coordinate,
- ω – rotating speed,
- ρ – density of magnetic fluid.

The ratio between pressures p_c and p_m is:

$$\eta = \frac{P_c}{P_m} = \frac{r^* \omega^2 \rho^* \delta}{2 \mu_0^* M^* H} \quad (3)$$

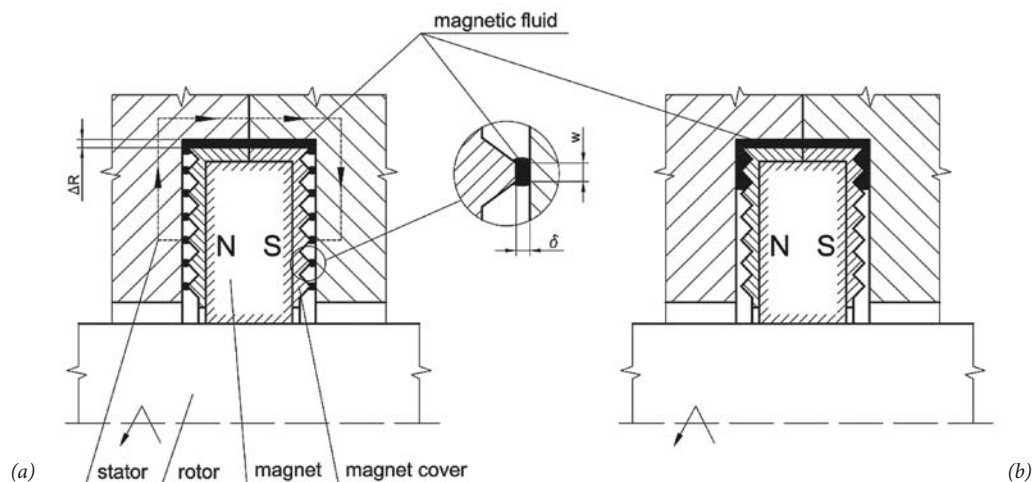

Fig. 1. Operation principle of centrifugal magnetic fluid seal (C.M.F.S.)
(a) position of magnetic fluid at low rotating speed, (b) position of magnetic fluid at high rotating speed

Thus, when the rotating speed ω is low, η will be less than unity and the sealing pressure will be governed by magnetic attraction. Conversely, when the rotating speed ω is high, η will be greater than unity and the sealing pressure will be generated by the centrifugal force. This phenomenon is illustrated in Fig. 2 [11].

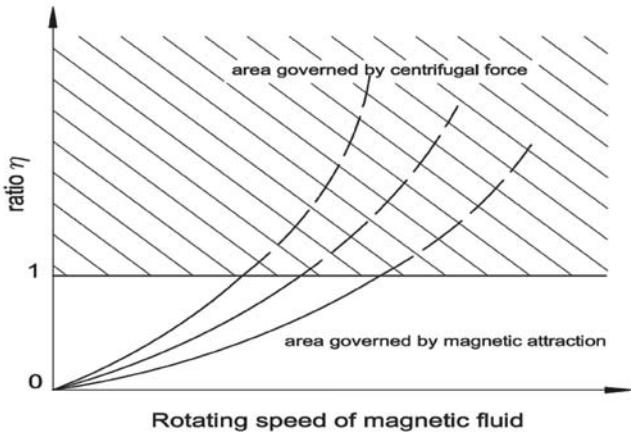

Fig. 2. Relation between the effect of magnetic attraction and centrifugal force in centrifugal magnetic fluid seal

BASIC DESIGNS OF CENTRIFUGAL MAGNETIC FLUID SEALS

Fig. 3 present the design of the centrifugal magnetic fluid seal with disc of rectangular cross-section and stationary magnetic system [16]. The seal consists of: axially polarized permanent magnets 5, two inner pole pieces 6, elements of housing 3, 4 with outer pole pieces in form of flanges 3a, 4a, and magnetic fluid 7. The pole pieces 3a, 4a have projections made on their inner cylindrical surfaces situated near shaft 1, while the pole pieces 6 have projections made on their side surfaces situated near the face of disc 2 mounted

on shaft 1. The permanent magnets 5 and the inner pole pieces 6 are placed in the elements of housing 3, 4.

At rest or at low rotary shaft speed (Fig. 3a), the magnetic fluid 7 is kept in the axial sealing gaps δ_a between the projections of inner pole pieces 6 and the face of disc 2, thus forming the sealing barriers. At high rotary shaft speed (Fig. 3b), the magnetic fluid 7 is moved from the stages toward the outer extending perimeter of the cavity formed between disc 2 and the elements of housing 3, 4, thus creating the sealing barrier.

Fig. 4 shows the centrifugal magnetic fluid seal for a rotating shaft with rotary magnetic system [17]. The seal consists of: elements of housing 2, 3, flanged sleeve 4, axially polarized permanent magnets 5, multi-edged pole pieces 6, and magnetic fluid 7. The flanged sleeve 4 is mounted on shaft 1. The permanent magnets 5 with pole pieces 6 adhere with the same N poles to two side surfaces of flange 4a. The magnets 5 and the pole pieces 6 are fastened to the outer cylindrical surfaces of sleeve 4. The multi-edged pole pieces 6 have sealing projections made on their outer side surfaces. Similar sealing projections are also made on outer cylindrical surfaces of the flanged sleeve 4, at its both ends. At rest or at low rotary speed of shaft 1 (Fig. 4a), the magnetic forces keep the magnetic fluid 7 in the axial gaps δ_a between the sealing projections of pole pieces 6 and the side surfaces of recesses in elements of housing 2, 3, as well as in the radial gaps δ_r between sealing projections of flanged sleeve 4 and inner cylindrical surfaces of elements of housing 2, 3, thus creating the sealing barriers. At high rotary speed of shaft 1 (Fig. 4b), the action of the centrifugal force, which is greater at that moment than the magnetic attraction force, moves the magnetic fluid 7 from the axial gaps δ_a to the circumferential gaps δ_o situated around the outer cylindrical surfaces of pole pieces 6. This ferrofluid, together with the magnetic fluid 7 in the radial gaps δ_r , forms a layer being the sealing barrier for the working medium.

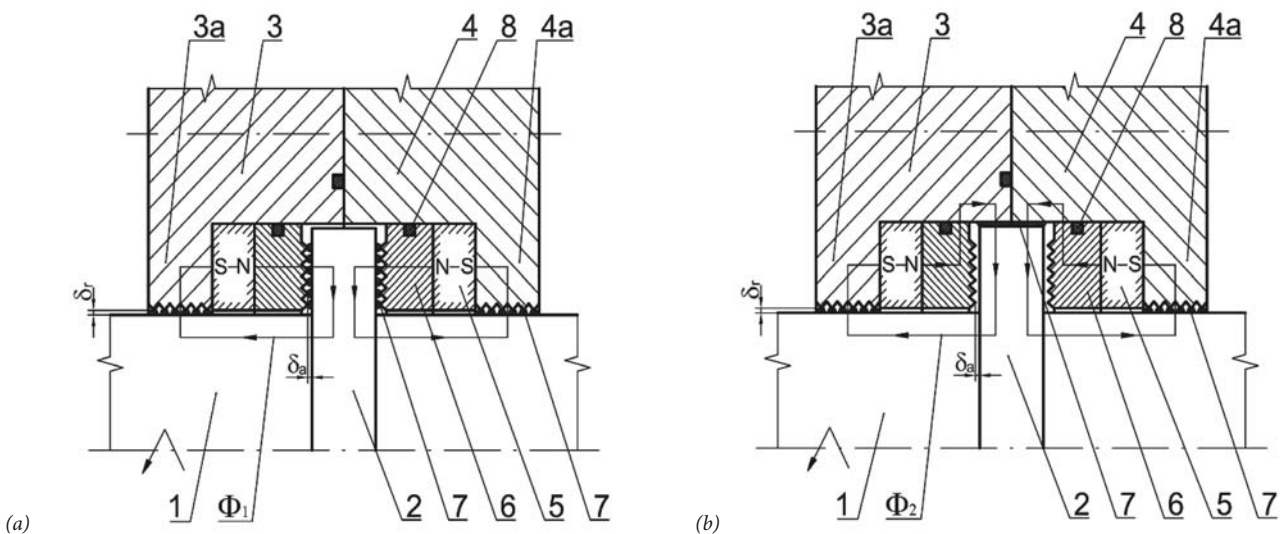

Fig. 3. Centrifugal magnetic fluid seal with disc of rectangular cross-section and stationary magnetic system (a) at low rotating shaft speed, (b) at high rotating shaft speed: 1 - shaft, 2 - disc, 3, 4 - elements of housing, 3a, 4a - outer pole pieces, 5 - permanent magnet, 6 - inner pole piece, 7 - magnetic fluid, 8 - "O"-ring seal, δ_a - axial sealing gap, δ_r - radial sealing gap, Φ_1 , Φ_2 - closed magnetic circuits

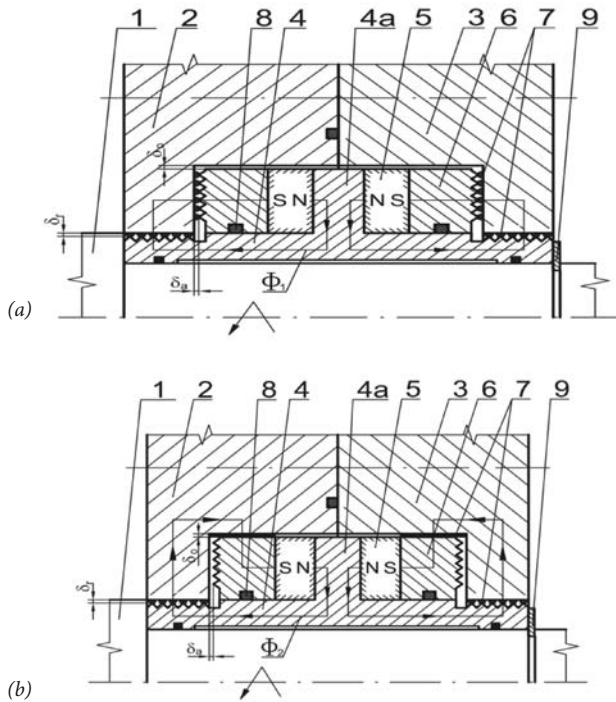

Fig. 4. Centrifugal magnetic fluid seal for rotating shaft with rotary magnetic system (a) at low rotating shaft speed, (b) at high rotating shaft speed: 1 - shaft, 2, 3 - elements of housing, 4 - flanged sleeve, 4a - flange, 5 - permanent magnet, 6 - pole piece, 7 - magnetic fluid, 8 - "O"-ring seal, 9 - snap ring, δ_a - axial sealing gap, δ_r - radial sealing gap, δ_o - circumferential sealing gap, Φ_1 , Φ_2 - closed magnetic circuits

Fig. 5 shows the design of the centrifugal magnetic fluid seal with disc of vee-shaped cross section and stationary magnetic system [18]. The seal consists of: axially polarized permanent magnet 4, two pole pieces 5, and magnetic fluid 6. The permanent magnet 4 and the pole pieces 5 are mounted in the recess of housing 2. The disc 3 with conical side surfaces is mounted on shaft 1. Projections of triangular cross-section are

made on the conical side surfaces of pole pieces 5. At rest or at low rotational speed of shaft 1 (Fig. 5a), the strong magnetic field keeps the magnetic fluid 6 in the sealing gaps δ_a between the projections of pole pieces 5 and disc 3, thus providing hermetic sealing. In this case the permanent magnet 4, the pole pieces 5, and the disc 3 form a closed magnetic circuit Φ . At high rotational speed of shaft 1 (Fig. 5b), the action of the centrifugal force, which is greater at that moment than the magnetic attraction force, moves the magnetic fluid 6 from the sealing stages towards the outer perimeter of disc 3. In this case the magnetic fluid 6 fills a small passageway between the top of disc 3 and the magnet 4, thus forming a seal which operates in the centrifugal sealing mode.

Fig. 6 shows the centrifugal magnetic fluid seal with disc of vee-shaped cross-section and rotating magnetic system [19]. The seal consists of: rotating shaft 1, multi-edged pole pieces 3, axially polarized permanent magnet 4, rings 5 of trapezoidal cross-sections, magnetic fluid 6, cover 9, and non-magnetic ring 10. The rings 5 are mounted in the recess of housing 2, while the multi-edged pole pieces 3, having the form of sleeves with flanges 3a of conical outer surfaces, are mounted on shaft 1 equipped with flange 1a. The inclination angle of the conical surfaces in pole pieces 3 is the same as that in rings 5. Sealing projections are made on conical surfaces of flanges 3a of pole pieces 3. The permanent magnet 4, with the non-magnetic ring 10 fastened onto it, is mounted on flange 1a of shaft 1, between pole pieces 3. The flanges 3a of pole pieces 3, together with permanent magnet 4 and ring 10, are mounted with some clearance between rings 5. At rest or at low rotary speed of shaft 1 (Fig. 6a), the magnetic forces keep the magnetic fluid 6 in the gaps δ between the sealing projections of pole pieces 3 and the conical surfaces of rings 5, thus creating the sealing barriers. At high rotary speed of shaft 1 (Fig. 6b), the magnetic fluid 6 is moved to the gap between the inner cylindrical surface of the housing recess and the outer moving part of the sealing, thus creating the liquid barrier for the sealed medium.

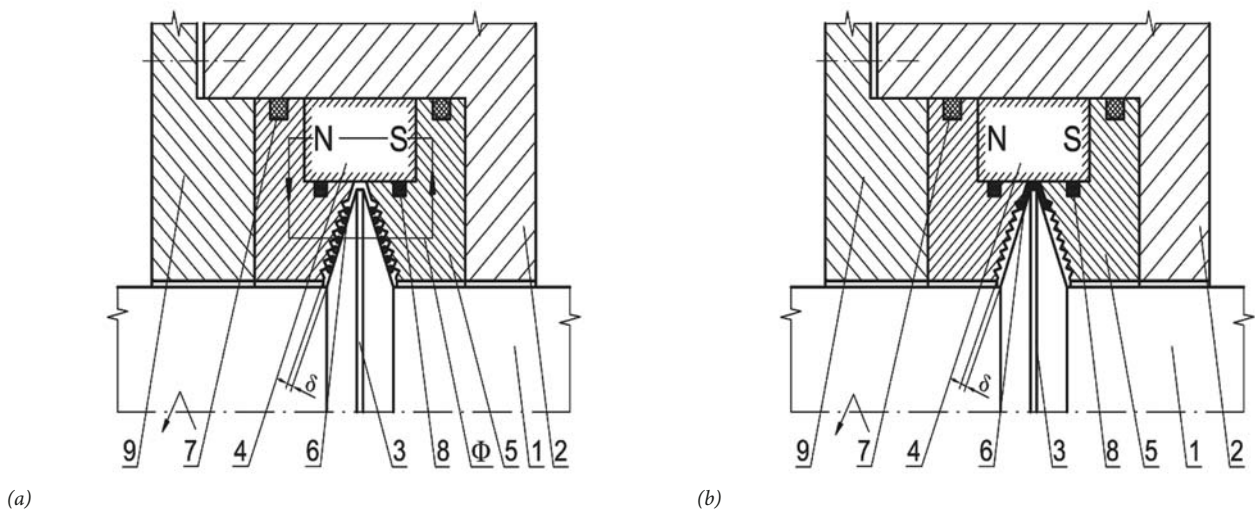

Fig. 5. Centrifugal magnetic fluid seal with disc of vee-shaped cross-section and stationary magnetic system (a) at low rotating shaft speed, (b) at high rotating shaft speed: 1 - shaft, 2 - housing, 3 - disc of vee-shaped cross-section, 4 - permanent magnet, 5 - pole piece, 6 - magnetic fluid, 7, 8 - "O"-ring seals, 9 - cover, δ - sealing gap, Φ - closed magnetic circuit

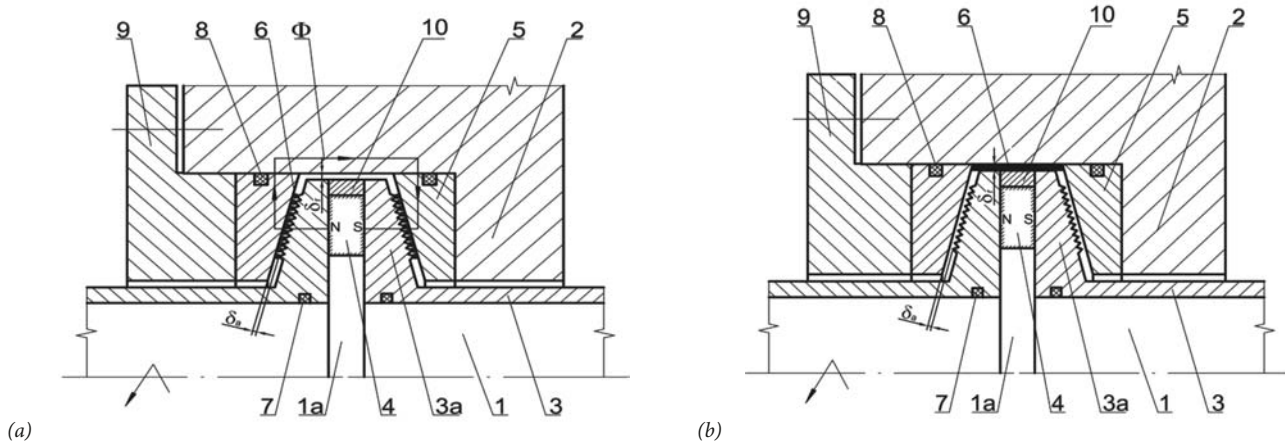

Fig. 6. Centrifugal magnetic fluid seal with disc of vee-shaped cross-section and rotary magnetic system (a) at low rotating shaft speed, (b) at high rotating shaft speed: 1 - rotating shaft, 1a - flange of shaft, 2 - housing, 3 - pole piece, 3a - flange, 4 - permanent magnet, 5 - ring of trapezoidal cross-section, 6 - magnetic fluid, 7, 8 - "O" - rings seals, 9 - cover, 10 - non-magnetic ring, δ_a - axial sealing gap, δ_r - radial sealing gap, Φ - closed magnetic circuit

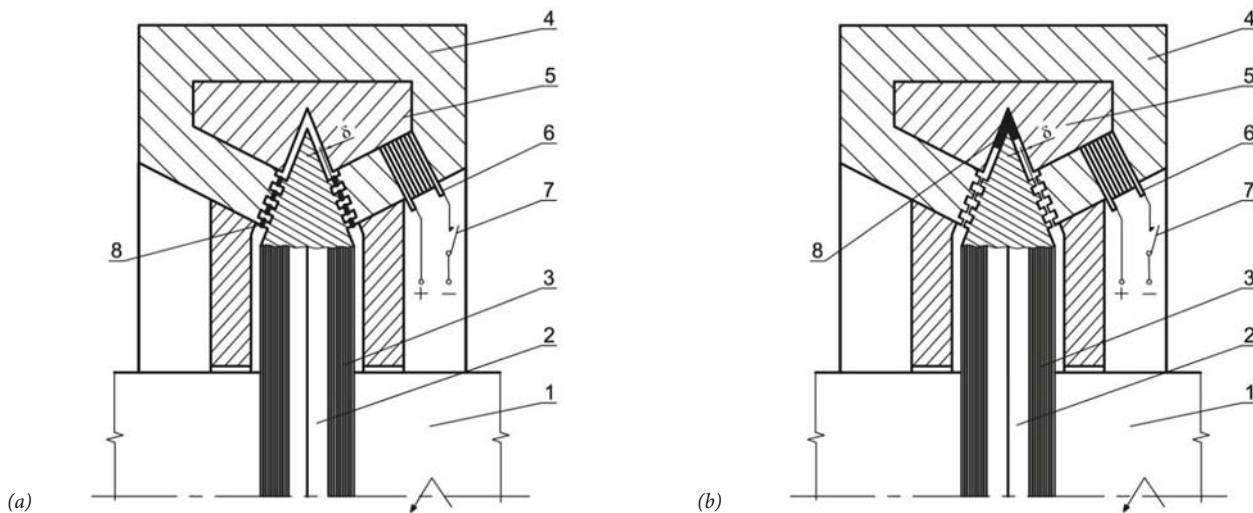

Fig. 7. Vee-shaped magnetic/centrifugal fluid seal (a) at low rotating shaft speed, (b) at high rotating shaft speed: 1 - shaft, 2 - disc of vee-shaped cross-section, 3 - projection, 4 - magnetic core, 5 - housing, 6 - electromagnetic coil, 7 - switch, 8 - magnetic fluid, δ - sealing gap

Fig. 7 presents the design of the vee-shaped magnetic/centrifugal fluid seal [20]. The seal comprises the rotating shaft 1, which is journaled within and supported by the housing 5. The circular disc 2 having an outer, peripheral vee-shaped cross-section is mounted on shaft 1. The housing 5 has a complementary vee-shaped cross-section part within which the vee-shaped disc 2 rides. Radially extending projections of rectangular cross-section are formed on disc 2 and on the magnetic core 4 of the horseshoe-shaped cross-section. The magnetic field can be generated by a permanent magnet or an electromagnet. If the permanent magnet is employed, then it would be inserted as part of the horseshoe-shaped core 4. If the electromagnet is used, it would employ an electromagnetic coil 6 energized from a DC source, via the selectively operable on-off switch 7. At rest or at low rotating shaft speed (Fig. 7a), the magnetic fluid 8 is kept in the gaps δ between the projections on disc 2 and on the horseshoe-shaped core 4, thus forming the multi-stage magnetic fluid seal. At high rotating shaft speed, the

centrifugal force acting on the ferrofluid 8 is greater than the magnetic forces keeping the ferrofluid 8 between the projections and moves the fluid into the vee-shaped part, as shown in Fig. 7b. In this case the seal operates in the centrifugal sealing mode.

Fig. 8 shows the design of the centrifugal magnetic fluid seal with stationary vane and rotating magnetic system [21]. The seal consists of the fluid cavity composed of the rotatable magnetic structure assembly 3-6 and the stationary holder 7, 8 with vane 9. The vane 9 with blade 10 and projections 11 of rectangular cross-section located on its side surfaces completes the magnetic circuit Φ . At rest or low rotating shaft speed (Fig. 8a), the strong magnetic field gradients keep the ferrofluid 13 in the gaps δ under each sealing stage, thus providing the necessary differential pressure capability. At high rotating shaft speed (Fig. 8b), the centrifugal force is greater than the magnetic attraction forces in the multistage seal and moves the ferrofluid 13 from the sealing gaps δ to the top cavity blade passageway, thus forming the ferrofluid barrier around the blade 10.

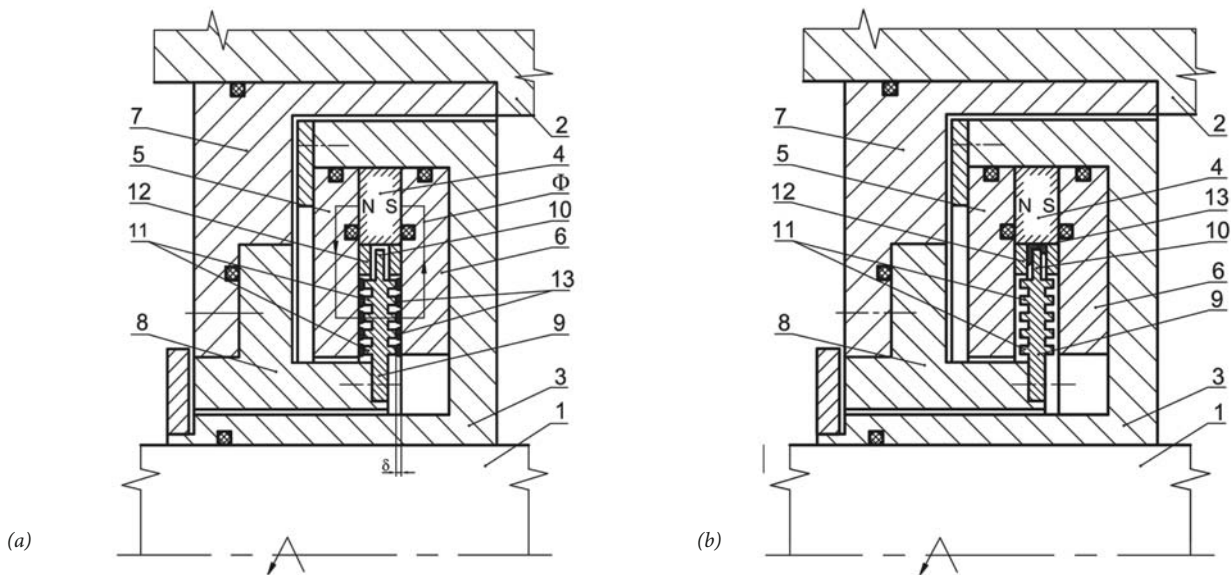

Fig. 8. Ferrofluid centrifugal seal with stationary vane and rotating magnetic system (a) at low rotating shaft speed, (b) at high rotating shaft speed: 1 – shaft, 2 – housing, 3 – movable holder, 4 – permanent magnet, 5, 6 – pole pieces, 7, 8 – elements of stationary holder, 9 – vane, 10 – blade, 11 – projections, 12 – spacing ring, 13 – ferrofluid, δ – sealing gap, Φ – closed magnetic circuit

SELECTED NEW DESIGNS OF CENTRIFUGAL MAGNETIC FLUID SEALS

Fig. 9 shows the centrifugal seal with magnetic fluid and stationary magnetic system [22]. The seal consists of: flanged sleeve 4 mounted on shaft 1, multi-edged pole pieces 5 and 6, axially polarized permanent magnets 7, non-magnetic sleeves 9, and magnetic fluid 8. The pole pieces 5, having the angle-bar cross-sections, are placed in recesses made in elements of housing 2, 3, on both sides of flange 4a of sleeve 4. In turn, the pole pieces 6, of rectangular cross-sections, are mounted in the recesses of pole pieces 5. The pole pieces 6 are separated from pole pieces 5 by permanent magnets 7 and non-magnetic sleeves 9. The pole pieces 5 have sealing

projections on inner cylindrical surfaces of their flanges and on front surfaces of their arms, while the pole pieces 6 have sealing projections on their inner cylindrical surfaces. At rest or at low rotary speed of shaft 1 (Fig. 9a), the magnetic fluid 8 fills the axial gaps δ_a between the sealing projections situated on front surfaces of pole pieces 5 and side surfaces of flange 4a of sleeve 4, and the radial gaps δ_r between the sealing projections on inner cylindrical surfaces of pole pieces 5, 6 and the outer cylindrical surfaces of flanged sleeve 4, thus creating the sealing barriers. At high rotary speed of shaft 1 (Fig. 9b), the magnetic fluid 8 is moved from the axial gaps δ_a to the gap created in elements of housing 2, 3 around the flange 4a of sleeve 4, along its perimeter, thus forming a liquid ring being an additional sealing barrier for the working medium.

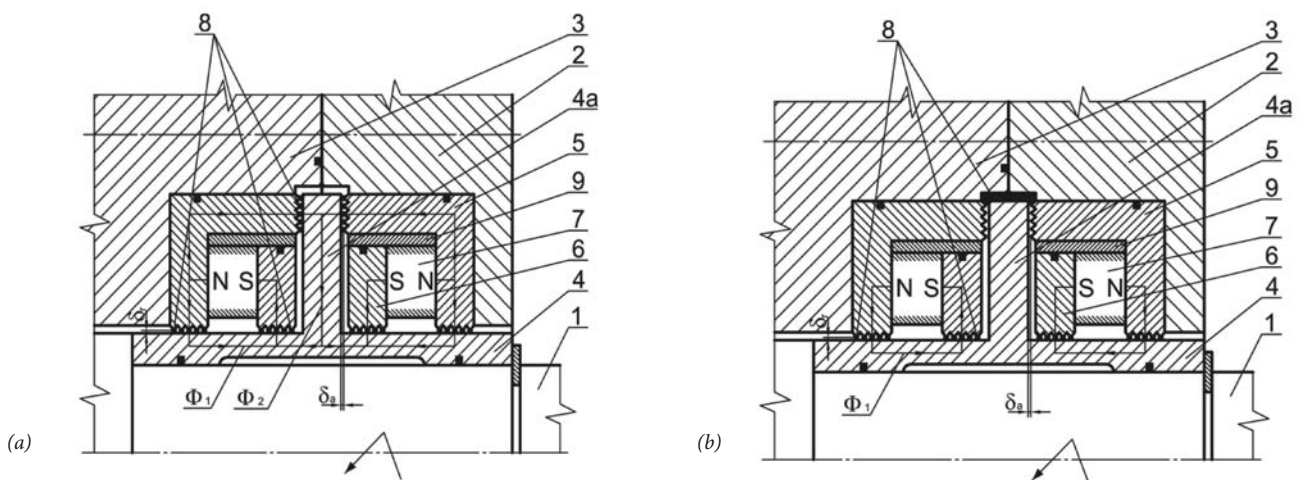

Fig. 9. Centrifugal seal with magnetic fluid and stationary magnetic system (a) position of magnetic fluid at low rotating speed, (b) position of magnetic fluid at high rotating speed; 1 – shaft, 2, 3 – elements of housing, 4 – flanged sleeve, 4a – flange, 5, 6 – multi-edged pole pieces, 7 – permanent magnet, 8 – magnetic fluid, 9 – non-magnetic sleeve, δ_a – axial sealing gap, δ_r – radial sealing gap, Φ_1 , Φ_2 – closed magnetic circuits

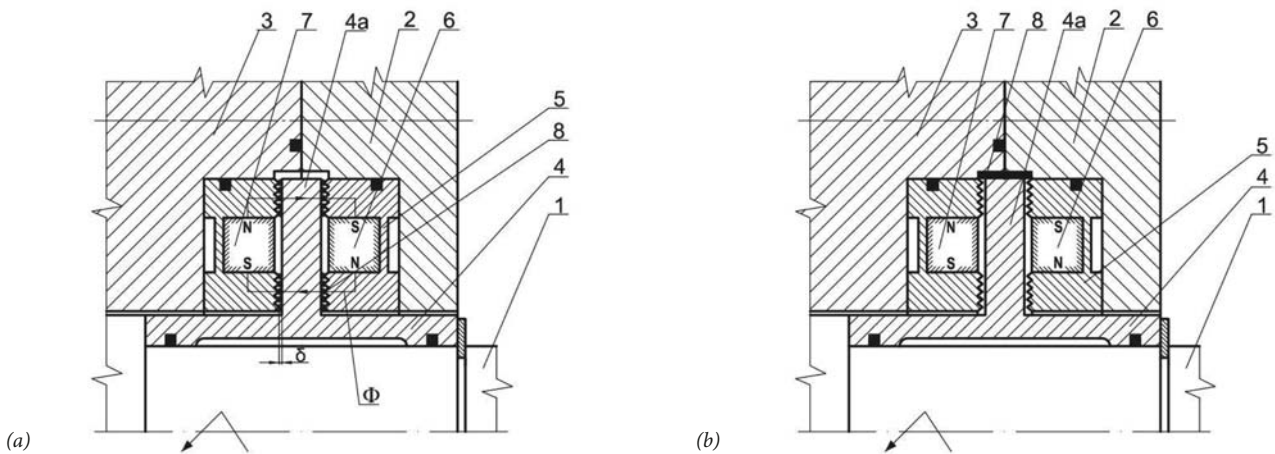

Fig. 10. Centrifugal seal with magnetic fluid (a) position of magnetic fluid at low rotating speed, (b) position of magnetic fluid at high rotating speed
 1 – shaft, 2, 3 – elements of housing, 4 – flanged sleeve, 4a – flange, 5 – multi-edged pole piece, 6, 7 – permanent magnets polarized radially, 8 – magnetic fluid, δ – sealing gap, Φ – closed magnetic circuit

Another design of the centrifugal seal with magnetic fluid and stationary magnetic system is shown in Fig. 10 [23]. This seal consists of: flanged sleeve 4 mounted on shaft 1, multi-edged pole pieces 5, permanent magnets 6, 7, and magnetic fluid 8. The pole pieces 5, having the angle-bar cross-sections, are placed in recesses made in elements of housing 2, 3, on both sides of flange 4a of sleeve 4. In turn, the radially polarized permanent magnets 6, 7 are mounted in the recesses of pole pieces 5. The magnet 6 is polarized in the N-S pole arrangement, while the magnet 7 – in the S-N arrangement with respect to shaft 1. The pole pieces 5 have sealing projections on their front surfaces directed towards the side surfaces of flange 4a of sleeve 4. At rest or at low rotary speed of shaft 1 (Fig. 10a), the magnetic fluid 8 fills the axial gaps δ between the sealing projections of pole pieces 5 and the side surfaces of flange 4a of sleeve 4, thus creating the sealing barriers. At high rotary speed of shaft 1 (Fig. 10b), the magnetic fluid 8 is moved from the axial gaps δ to the gap created in the elements of housing 2, 3 around the flange 4a, along its perimeter, thus forming a liquid ring being in this case the sealing barrier for the working medium.

Fig. 11 shows the centrifugal seal with magnetic liquid for high-speed shaft with movable magnetic system [24]. The seal consists of: flanged sleeve 3 mounted on shaft 1, axially polarized cylindrical permanent magnets 4, multi-edged pole pieces 5, magnetic fluid 6, and cover 7. The multi-edged pole pieces 5 of rectangular cross-section, with sealing projections situated on their outer side surfaces, are mounted in sockets made on the side surfaces of flange 3a of sleeve 3. The cylindrical permanent magnets 4 are placed in holes evenly distributed around the perimeter in the necking of flange 3a of sleeve 3, situated between pole pieces 5. The flange 3a of sleeve 3 with magnets 4 and pole pieces 5 is mounted, with some clearance, in the recess of housing 2 covered with cover 7. At rest or at low rotary speed of shaft 1 (Fig. 11a), the magnetic fluid 6 is kept in the axial gaps δ_a between the sealing projections of pole pieces 5 and the side surfaces of the recess in housing 2 and cover 7, thus creating the sealing barriers. At high rotary speed of shaft 1 (Fig. 11b), the magnetic fluid 6 is moved from the axial gaps δ_a to the radial gap δ_r situated around flange 3a of sleeve 3, along its perimeter, thus forming a liquid ring being in this case the sealing barrier for the working medium.

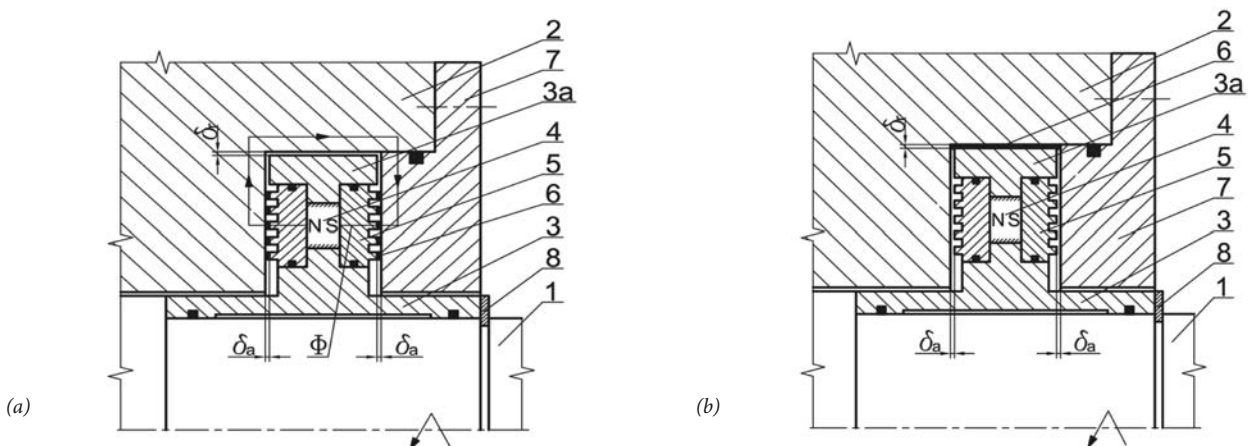

Fig. 11. Centrifugal seal with magnetic fluid for high-speed shaft and movable magnetic system (a) position of magnetic fluid at low rotating speed, (b) position of magnetic fluid at high rotating speed
 1 – shaft, 2 – housing, 3 – flanged sleeve, 3a – flange, 4 – cylindrical permanent magnet, 5 – multi-edged pole piece, 6 – magnetic fluid, 7 – cover, 8 – snap ring, δ_a – axial sealing gap, δ_r – radial sealing gap, Φ – closed magnetic circuit

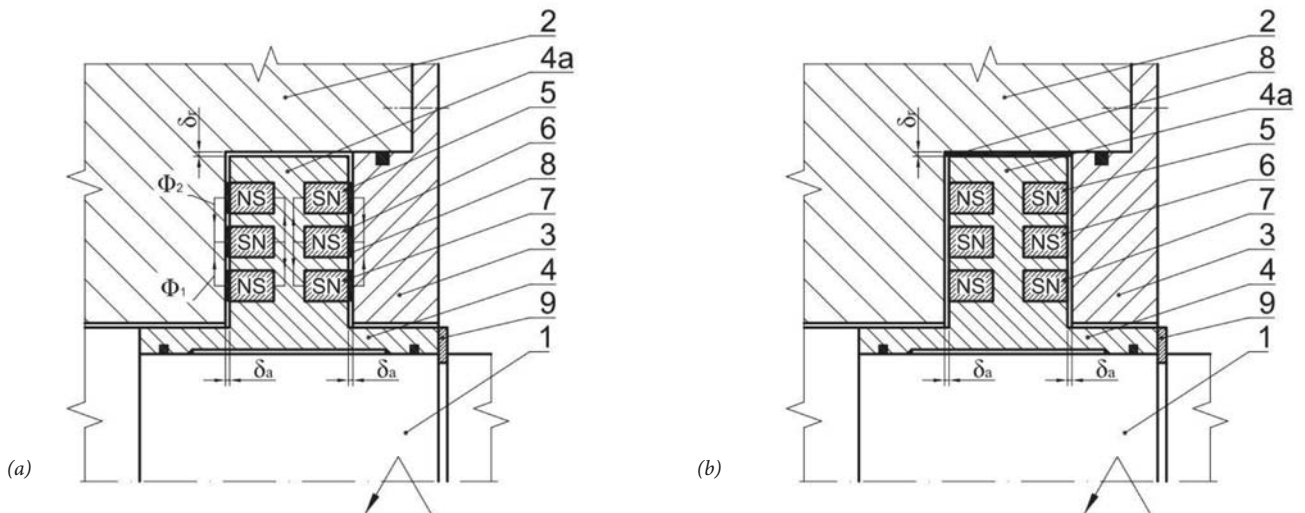

Fig. 12. Centrifugal seal with magnetic fluid for rotating shaft and movable magnetic system (a) position of magnetic fluid at low rotating speed, (b) position of magnetic fluid at high rotating speed 1 - shaft, 2 - housing, 3 - cover, 4 - flanged sleeve, 4a - flange, 5, 6, 7 - annular permanent magnets, 8 - magnetic fluid, 9 - snap ring, δ_a - axial sealing gap, δ_r - radial sealing gap, Φ_1 , Φ_2 - closed magnetic circuits

Another design of the centrifugal seal with magnetic fluid for rotating shaft and movable magnetic system is shown in Fig. 12 [25]. This seal consists of: flanged sleeve 4, axially polarized annular permanent magnets 5, 6, 7, magnetic fluid 8, and cover 3. The flange 4a of sleeve 4 mounted on shaft 1 is placed with some clearance in the recess of housing 2 covered with cover 3. The annular permanent magnets 5, 6, 7 are placed in sockets symmetrically distributed on side surfaces of flange 4a of sleeve 4. The poles of these magnets are arranged in turns, N-S-N, with respect to the side surfaces of flange 4a. At rest or at low rotary speed of shaft 1 (Fig. 12a), the magnetic fluid 8 is kept in the axial gaps δ_a between the end surfaces of permanent magnets 5, 6, 7, being the N or S poles, and the corresponding side surfaces of the recess in housing 2 and cover 3, thus creating the sealing barriers. At high rotary speed of shaft 1 (Fig. 12b), the magnetic fluid 8 is moved from the axial gaps δ_a to the radial gap δ_r situated between flange 4a of sleeve 4, along its perimeter, and the

inner cylindrical surface of the recess in housing 2, thus forming a liquid ring being in this case the sealing barrier for the working medium.

SELECTED APPLICATIONS OF CENTRIFUGAL MAGNETIC FLUID SEALS IN MODERN SEALING TECHNOLOGY

Fig. 13 shows an example of application of the compact, centrifugal seal with magnetic fluid for rolling bearing [26]. The seal consists of: the outer pole piece 7, of L-shaped cross-section, mounted in housing 2, the inner pole piece 6, also of L-shaped cross-section, placed by overlapping in the outer pole piece 7, and the axially polarized annular permanent magnet 5 placed in the non-magnetic sleeve 4 mounted on shaft 1. At rest

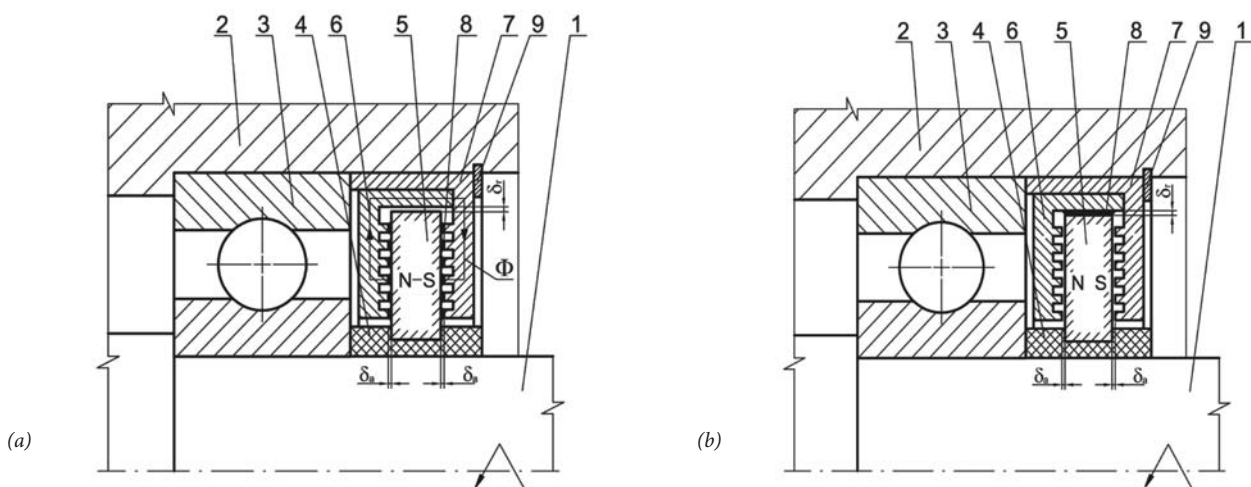

Fig. 13. Compact centrifugal seal with magnetic fluid for rolling bearing (a) position of magnetic fluid at low rotating speed, (b) position of magnetic fluid at high rotating speed 1 - shaft, 2 - housing, 3 - rolling bearing, 4 - sleeve, 5 - annular permanent magnet, 6 - inner pole piece, 7 - outer pole piece, 8 - magnetic fluid, δ_a - axial sealing gap, δ_r - radial sealing gap, Φ - closed magnetic circuit

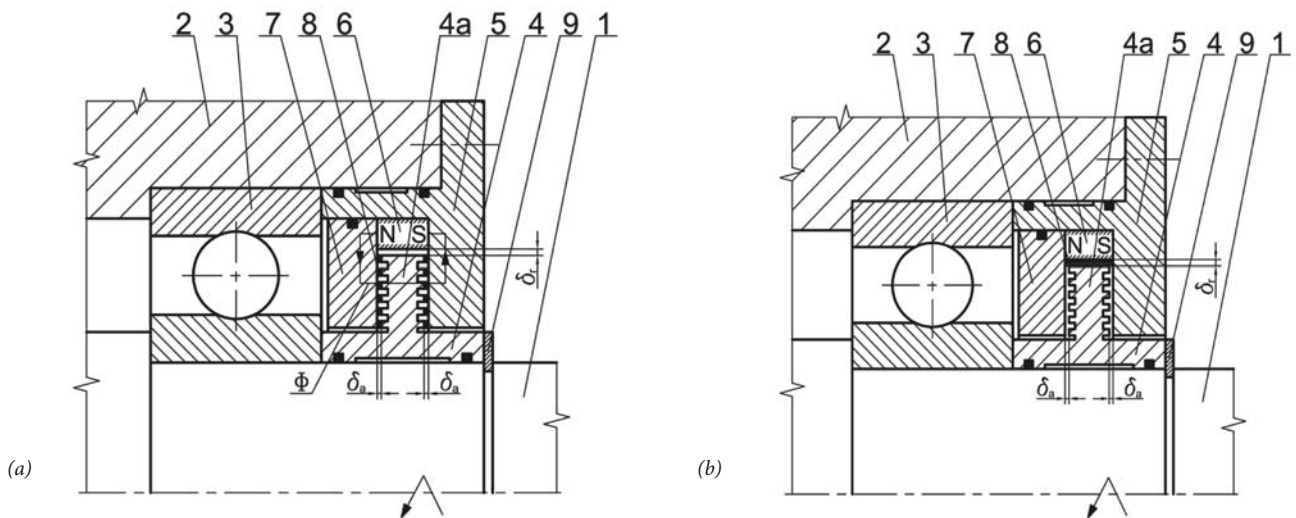

Fig. 14. Hybrid protective seal with magnetic fluid for rolling bearing (a) position of magnetic fluid at low rotating speed, (b) position of magnetic fluid at high rotating speed 1 – shaft, 2 – housing, 3 – rolling bearing, 4 – flanged sleeve, 4a – flange, 5 – cover, 6 – permanent magnet, 7 – pole piece, 8 – magnetic fluid, 9 – snap ring, δ_a – axial sealing gap, δ_r – radial sealing gap, Φ – closed magnetic circuit

or at low rotary speed of shaft 1 (Fig. 13a), the magnetic fluid 8 fills the axial gaps δ_a between the sealing projections on side surfaces of the arms of pole pieces 6, 7 and the side surfaces of permanent magnet 5, thus creating the sealing barriers. At high rotary speed of shaft 1 (Fig. 13b), the magnetic fluid 8 is moved to the radial gap δ_r situated between the permanent magnet 5 and the inner pole piece 6, thus forming the layer of liquid being in this case the sealing barrier for the working medium.

Fig. 14 shows the hybrid protective seal with magnetic fluid for rolling bearing [27]. The seal consists of: flanged sleeve 4, cover 5, axially polarized permanent magnet 6, pole piece 7 of rectangular cross-section, and magnetic fluid 8. The flanged sleeve 4 mounted on shaft 1 adheres to the inner ring of rolling bearing 3 and has flange 4a directed towards housing 2. Sealing projections are made on side surfaces of flange 4a of sleeve 4. The permanent magnet 6 and the pole piece 7 are mounted in recesses made in cover 5, while the flange 4a of sleeve 4 is mounted with some clearance, in the

chamber created by cover 5, permanent magnet 6, and pole piece 7. At rest or at low rotary speed of shaft 1 (Fig. 14a), the magnetic forces keep the magnetic fluid 8 in the axial gaps δ_a between the sealing projections on flange 4a of sleeve 4 and the side surfaces of pole piece 7 and cover 5, thus creating the sealing barriers. At high rotary speed of shaft 1 (Fig. 14b), the magnetic fluid 8 is moved from the axial gaps δ_a to the radial gap δ_r around the flange 4a, along its perimeter, and forms a liquid ring being in this case the sealing barrier, which protects the rolling bearing 3 against penetration of impurities into it. Moreover, the axial-radial labyrinth seal created by the flanged sleeve 4 and cover 5 with magnet 6 and pole piece 7 acts as an additional sealing barrier.

Fig. 15 shows the double sealing system for shaft in vertical arrangement. The seal consists of the centrifugal seal with magnetic fluid, situated over the rolling bearing 3, and the outer axial labyrinth seal. The labyrinth seal consists of the stationary flanged sleeve 4 fixed to housing 2 and the movable

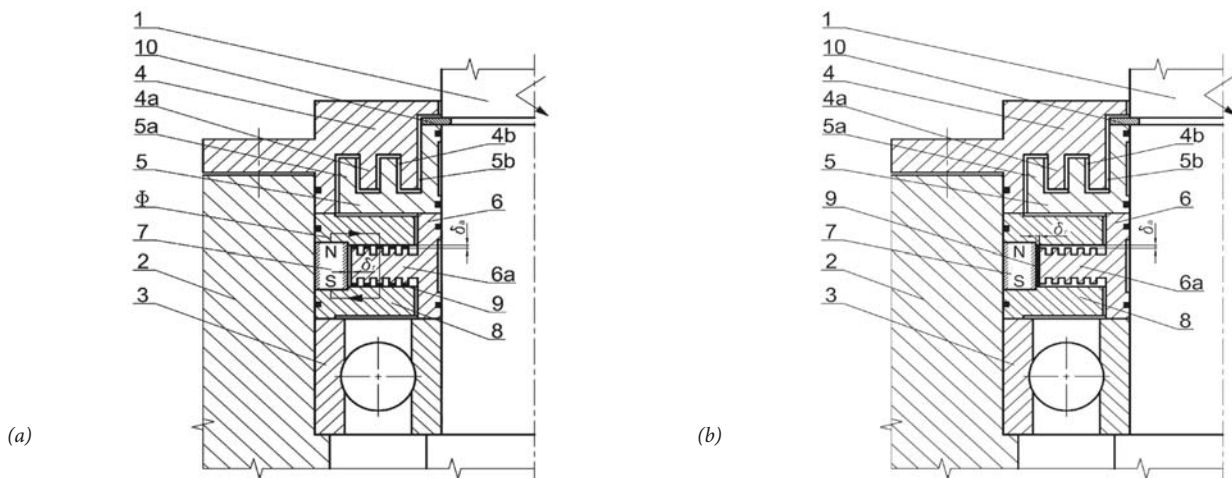

Fig. 15. Double sealing system for shaft in vertical arrangement (a) position of magnetic fluid at low rotating speed, (b) position of magnetic fluid at high rotating speed 1 – vertical shaft, 2 – housing, 3 – rolling bearing, 4 – stationary flanged sleeve, 4a – annular projection, 4b – annular cavity, 5 – movable flanged sleeve, 5a – annular projection, 5b – annular cavity, 6 – bushing, 6a – flange with sealing projections, 7 – permanent magnet, 8 – pole piece, 9 – magnetic fluid, 10 – snap ring, δ_a – axial sealing gap, δ_r – radial sealing gap, Φ – closed magnetic circuit

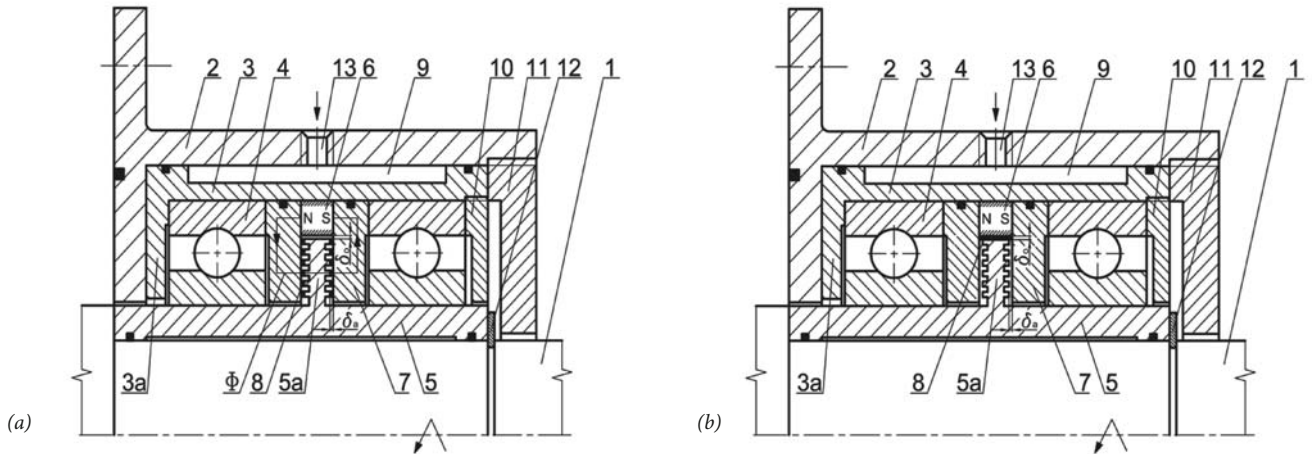

Fig. 16. Feedthrough of high-speed shaft with magnetic fluid centrifugal seal (a) position of magnetic fluid at low rotating speed, (b) position of magnetic fluid at high rotating speed 1 – shaft, 2 – housing, 3 – stationary flanged sleeve, 3a – flange, 4 – rolling bearing, 5 – movable flanged sleeve, 5a – flange with sealing projections, 6 – cylindrical permanent magnet, 7 – pole piece, 8 – magnetic fluid, 9 – cooling chamber, 10, 11 – setting nuts, 12 – snap ring, 13 – hole for cooling medium, δ_a – axial sealing gap, δ_r – circumferential sealing gap, Φ – closed magnetic circuit

flanged sleeve 5 with suitable recesses and projections mounted on shaft 1. The centrifugal seal consists of the bushing 6 with flange 6a directed towards housing 2 mounted on shaft 1, and two pole pieces 8 of rectangular cross-section separated by the axially polarized permanent magnet 7 mounted in housing 2. The flange 6a of bushing 6 has sealing projections on its side surfaces. At rest or at low rotary speed of shaft 1 (Fig. 15a), the magnetic forces keep the magnetic fluid 9 in the axial gaps δ_a between the sealing projections on flange 6a of sleeve 6 and the inner side surfaces of pole pieces 8, thus creating the sealing barriers. At high rotary speed of shaft 1 (Fig. 15b), the magnetic fluid 9 is moved from the axial gaps δ_a to the radial gap δ_r situated around the flange 6a, along its perimeter, thus forming a liquid ring being an additional sealing barrier which protects the rolling bearing 3 against penetration of impurities.

Fig. 16 presents the design of the feedthrough of high-speed shaft with centrifugal magnetic fluid seal, used in low-pressure and vacuum applications [28]. The feedthrough

of shaft 1 consists of: housing 2, stationary flanged sleeve 3 with flange 3a, movable flanged sleeve 5 with flange 5a, rolling bearings 4, axially polarized permanent magnet 6, pole pieces 7, and magnetic fluid 8. The stationary flanged sleeve 3 with flange 3a directed towards shaft 1 is mounted in the housing 2, while the movable flanged sleeve 5 with flange 5a directed towards the housing 2 and equipped with sealing projections is mounted on the rotating shaft 1. The pole pieces 7 of rectangular cross-section, separated by the permanent magnet 6, are mounted in the chamber between the rolling bearings 4 fastened in sleeves 3, 5, while the flange 5a of sleeve 5a is mounted with some clearance between the side surfaces of pole pieces 7. The outer cylindrical surface of the stationary flanged sleeve 3 has a circumferential recess which, together with the inner cylindrical surface of housing 2, creates the cooling chamber 9. The hole 13 in housing 2 is used for delivering the cooling medium to chamber 9. At rest or at low rotary speed of shaft 1 (Fig. 16a),

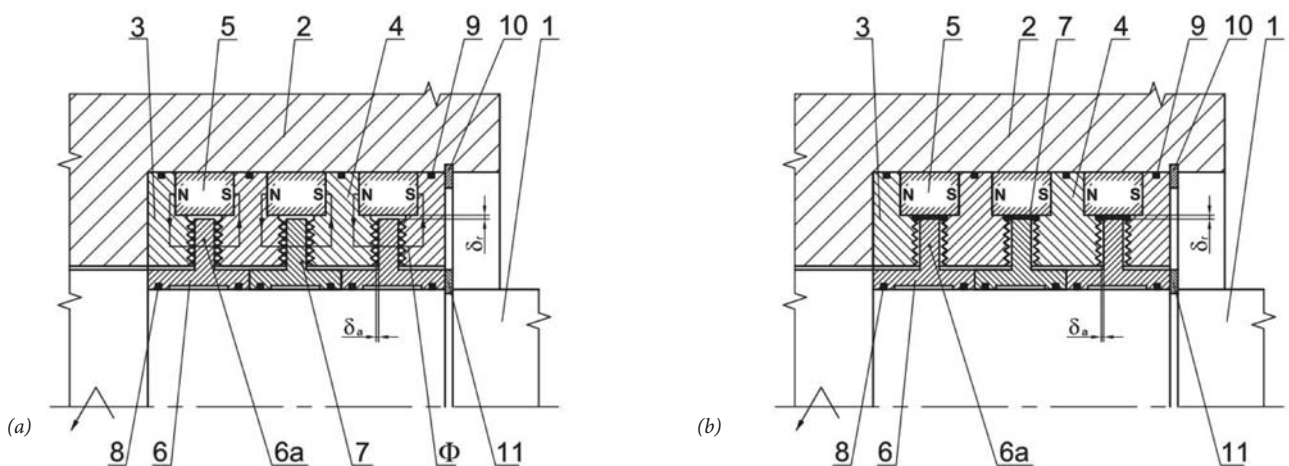

Fig. 17. Multi-staged ferromagnetic seal for rotating shaft (a) position of magnetic fluid at low rotating speed, (b) position of magnetic fluid at high rotating speed, 1 – shaft, 2 – housing, 3, 4 – multi-edged pole pieces, 5 – permanent magnet, 6 – flanged sleeve, 6a – flange, 7 – ferromagnetic fluid, 8, 9 – “O” – ring seals, 10, 11 – snap rings, δ_a – axial sealing gap, δ_r – radial sealing gap, Φ – closed magnetic circuit

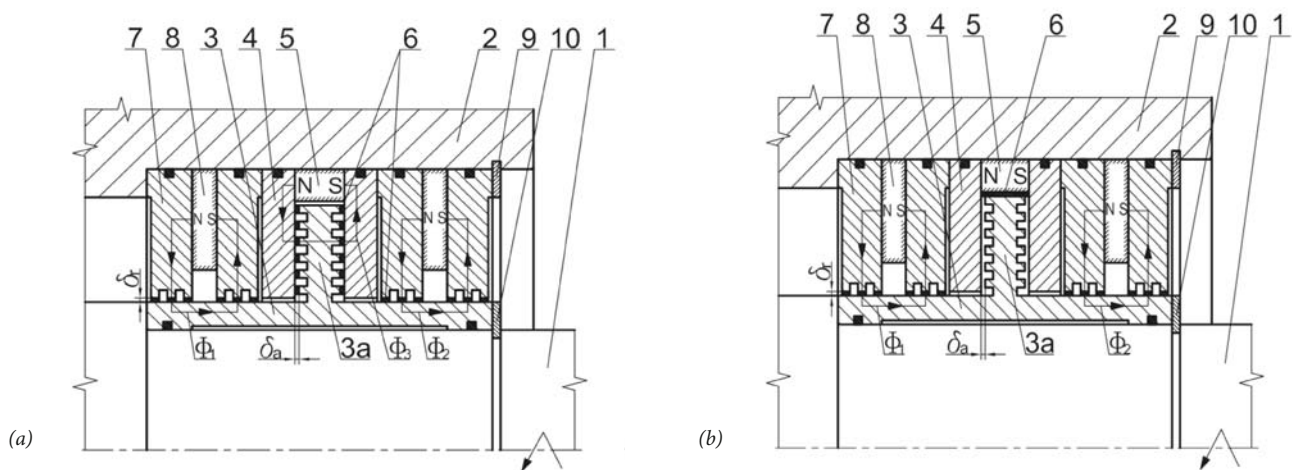

Fig. 18. Hybrid seal with magnetic fluid for high-speed shaft (a) position of magnetic fluid at low rotating speed, (b) position of magnetic fluid at high rotating speed, 1 – shaft, 2 – housing, 3 – flanged sleeve, 3a – flange with sealing projections, 4 – rectangular cross-section pole piece, 5, 8 – permanent magnets, 6 – magnetic fluid, 7 – multi-edged pole piece, 9, 10 – snap rings, δ_a – axial sealing gap, δ_r – radial sealing gap, Φ_1, Φ_2, Φ_3 – closed magnetic circuits

the magnetic fluid 8 fills the axial gaps δ_a between the sealing projections of flange 5a of movable sleeve 5 and the inner side surfaces of pole pieces 7, thus creating the sealing barriers. At high rotary speed of shaft 1 (Fig. 16b), the magnetic fluid 8 is moved to the circumferential gap δ_o between the cylindrical surface of flange 5a of movable sleeve 5 and the inner cylindrical surface of permanent magnet 6, thus forming a liquid ring being an additional sealing barrier for the working medium. Moreover, at high rotary speed of the shaft, the applied cooling system ensures maintaining the appropriate operating temperature of the seal, which increases its durability.

Fig. 17 presents the multi-staged ferromagnetic fluid seal for rotating shaft [29]. The seal consists of: multi-edged pole pieces 3 and 4, separated by axially polarized annual permanent magnets 5 and placed in the packing chamber in housing 2, and flanged sleeves 6 mounted on shaft 1. The side surfaces of pole pieces 3, 4 have sealing projections. The flanges 6a of sleeves 6 are placed, with some clearance, in the annular chambers created between pole pieces 3, 4 and permanent magnets 5. At rest or at low rotary speed of shaft 1 (Fig. 17a), the magnetic forces keep the ferromagnetic fluid 7 in the axial gaps δ_a between the sealing projections on pole pieces 3, 4 and the side surfaces of flanges 6a of sleeves 6, thus creating the sealing barriers. At high rotary speed of shaft 1 (Fig. 17b), the ferromagnetic fluid 7 is moved from the axial gaps δ_a to the radial gaps δ_r situated around flanges 6a of sleeves 6, along their perimeter, thus forming liquid rings being additional sealing barriers for the working medium.

Fig. 18 shows the hybrid seal with magnetic fluid which is especially applicable for high-speed shaft [30]. The seal consists of: flanged sleeve 3, axially polarized permanent magnets 5, 8, pole pieces 4 of rectangular cross-section, multi-edged pole pieces 7, and magnetic fluid 6. The flanged sleeve 3 is mounted on shaft 1 and has the flange 3a directed towards housing 2. Sealing projections are made on side

surfaces of flange 3a of sleeve 3 and on inner cylindrical surfaces of multi-edged pole pieces 7. The flange 3a of sleeve 3 is mounted with some clearance in the chamber created between the rectangular cross-section pole pieces 4 separated by the permanent magnet 5 and fastened in housing 2. Moreover, pairs of multi-edged pole pieces 7 separated by permanent magnets 8 are mounted in housing 2, on both sides of rectangular cross-section pole pieces 4. When the shaft 1 is at rest or rotates with low speed (Fig. 18a), the magnetic fluid 6 is kept in the radial gaps δ_r of two outer magnetic fluid seals and in the axial gaps δ_a of the centrifugal seal, thus creating the sealing barriers. At high rotary speed of shaft 1 (Fig. 18b), the magnetic fluid 6 is moved from the axial gaps δ_a of the centrifugal seal to the annular gap situated between the outer perimeter of flange 3a of sleeve 3 and the permanent magnet 5, thus forming an additional sealing barrier for the working medium.

CONCLUDING REMARKS

The centrifugal magnetic fluid seals have important advantage over the conventional centrifugal seals, as they maintain very good sealing capacity at static, medium and high speeds of the shaft, with the increased seal lifetime, and minimum torque and static friction. These seals are particularly useful in cases when the angular shaft velocity varies and may decrease to nearly or exactly zero, such as in flywheel applications for instance.

Compared to the ordinary magnetic fluid seal, the centrifugal magnetic fluid seal (CMFS) has the following three distinguishing features:

- 1) at stationary conditions and at low shaft rotating speed, the force caused by the effect of magnetic attraction is used for sealing, while at higher speed, it is the centrifugal force which provides the effective sealing action;

- 2) the CMFS operates well even in the presence of large rotational vibration amplitudes;
- 3) the centrifugal magnetic fluid seals ensure completely hermetic sealing of the shaft at static, low- and high-speed modes, with the increased seal lifetime, and minimum torque and static friction.

REFERENCES

1. Y. Mitamura, S. Takahashi, S. Amari, E. Okamoto, S. Murabayashi, I. Nishimura, *A magnetic fluid seal for rotary blood pumps: effects of seal structure on long-term performance in liquid*, J Artif Organs 14 (2011) 23–30.
2. J. Lee, C. Ahn, J. Choi, J. Park, S. Song, K. Sun, *Development of magnetic bearing system for a new third-generation blood pump*, Artif Organs 35 (11) (2011) 1082–1094.
3. Huang W, Wang X. *Ferrofluids lubrication: a status report*. Lubric Sci 2016;28:3–26.
4. Wang Z, Hu Z, Huang W, Wang X. *Elastic support of magnetic fluids bearing*. J Phys Appl Phys 2017;50:435004.
5. Li D, Xu H, He X, Lan H. *Study on the magnetic fluid sealing for dry Roots pump*. J Magn Magn Mater 2005;289:419–22.
6. Y. Mitamura et al., “A hydrodynamically suspended, magnetically sealed mechanically noncontact axial flow blood pump: Design of a hydrodynamic bearing,” Artif. Organs, 2007.
7. L. Matuszewski and Z. Szydło, “The application of magnetic fluids in sealing nodes designed for operation in difficult conditions and in machines used in sea environment,” Polish Marit. Res., 2008.
8. T. Kanno, Y. Kouda, Y. Takeishi, T. Minagawa, and Y. Yamamoto, “Preparation of magnetic fluid having active-gas resistance and ultra-low vapor pressure for magnetic fluid vacuum seals,” Tribol. Int., 1997.
9. T. Liu, Y. Cheng, and Z. Yang, “Design optimization of seal structure for sealing liquid by magnetic fluids,” in Journal of Magnetism and Magnetic Materials, 2005.
10. Raj K., Stahl P., Bottenberg W.: *Magnetic fluid seals for special applications*, LE Transactions, vol.23, no 4, 1980.
11. Mizumoto M., Imai M., Inoue H.: *Development of a centrifugal magnetic liquid seal for superconducting generators*, Proc. of the 9th Int. Conference on Fluid Sealing, Noordwijkerhout, Netherlands, 1981.
12. Wilcock D.F, Gay S.: *The role of magnetic fluid seal in modern machinery*, Lubrication Engineering, vol.40, no 6, 1984.
13. Ochoński W.: *Dynamic sealing with magnetic fluids*, Wear, vol. 130, no 1, 1989
14. Ochoński W.: *High technology of sealing solved by ferrofluids*, Industrial Lubrication and Tribology, vol. 45, no 4, 1993.
15. Ochoński W.: *New designs of magnetic fluid exclusion seals for rolling bearings*, Industrial Lubrication and Tribology, vol. 57, no 3, 2005.
16. Patent PL, Int.Cl. F16J15/43, no 202542, Centrifugal magnetic fluid shaft seal (in Polish).
17. Patent application PL, no P-420053 Centrifugal seal with magnetic fluid for high-speed shaft (in Polish).
18. Patent PL, Int.Cl. F16J15/453, no 174460, Ferromagnetic fluid centrifugal seal (in Polish).
19. Patent PL, Int.Cl.F16J15/53, no 202306, Centrifugal magnetic fluid seal for high -speed shaft (in Polish).
20. Patent USA, Int.Cl. F16J15/42, no 4455026, Vee-shaped magnetic/centrifugal seal and method of operation.
21. Patent USA, Int.Cl. F16J15/42, no 4200296, Ferrofluid centrifugal seal.
22. Patent PL, Int.Cl. F16J15/453, no 218345, Centrifugal seal with magnetic fluid (in Polish).
23. Patent PL, Int.Cl.F16J15/42, no 220279, Centrifugal seal with magnetic fluid (in Polish).
24. Patent application PL, no P-418800, Centrifugal seal with magnetic liquid for a high-speed shaft (in Polish).
25. Patent application PL, no P-423513, Centrifugal seal with magnetic fluid for rotating shaft (in Polish).
26. Patent PL, Int.Cl.F16J15-53, no 206282, Compact, centrifugal seal with magnetic fluid (in Polish).
27. Patent application PL, no P-419854, Hybrid protective seal with magnetic fluid for rotating bearing (in Polish).
28. Patent application PL, no P-418797, Feedthrough of high-speed shaft with centrifugal magnetic fluid seal (in Polish).
29. Patent PL, Int.Cl.F16J15/40, no 1`163174, Multistage ferromagnetic fluid seal (in Polish).
30. Patent application PL, no P-423713, Hybrid seal with magnetic fluid, especially for high-speed shaft (in Polish).
31. Y. Mitamura and C. A. Durst, “Miniature magnetic fluid seal working in liquid environments,” *J. Magn. Magn. Mater.*, 2017.

32. M. Cong and H. Shi, "A study of magnetic fluid rotary seals for wafer handling robot," in *15th International Conference on Mechatronics and Machine Vision in Practice, M2VIP'08*, 2008.
33. D. Li, H. Xu, X. He, and H. Lan, "Theoretical and experimental study on the magnetic fluid seal of reciprocating shaft," in *Journal of Magnetism and Magnetic Materials*, 2005.
34. M. Szczech and W. Horak, "Tightness testing of rotary ferromagnetic fluid seal working in water environment," *Ind. Lubr. Tribol.*, 2015.
35. H. Urreta, G. Aguirre, P. Kuzhir, and L. N. Lopez de Lacalle, "Seals Based on Magnetic Fluids for High Precision Spindles of Machine Tools," *Int. J. Precis. Eng. Manuf.*, 2018.
36. Y. Mitamura, S. Arioka, D. Sakota, K. Sekine, and M. Azegami, "Application of a magnetic fluid seal to rotary blood pumps," *J. Phys. Condens. Matter*, 2008.
37. Y. Mitamura, T. Yano, W. Nakamura, and E. Okamoto, "A magnetic fluid seal for rotary blood pumps: Behaviors of magnetic fluids in a magnetic fluid seal with a shield," *Magnetohydrodynamics*, 2013.
38. T. Dimond, R. D. Rockwell, P. N. Sheth, and P. E. Allaire, "A New Fluid Film Bearing Test Rig for Oil and Water Bearings," *Proc. ASME Turbo Expo 2008 Power Land, Sea Air*, 2008.
39. K. Sekine, Y. Mitamura, S. Murabayashi, I. Nishimura, R. Yozu, and D. W. Kim, "Development of a Magnetic Fluid Shaft Seal for an Axial-Flow Blood Pump," in *Artificial Organs*, 2003.
40. M. S. Krakov and I. V. Nikiforov, "Effect of diffusion of magnetic particles on the parameters of the magnetic fluid seal: A numerical simulation," *Magnetohydrodynamics*, 2014.
41. Y. Mitamura et al., "Sealing Performance of a Magnetic Fluid Seal for Rotary Blood Pumps," *Artif. Organs*, 2009.
42. S. Chen and D. Li, "Influence of particle size distribution of magnetic fluid on the resistance torque of magnetic fluid seal," *J. Magn.*, 2017.
43. A. Radionov, A. Podoltsev, and A. Zahorulko, "Finite-element analysis of magnetic field and the flow of magnetic fluid in the core of magnetic-fluid seal for rotational shaft," in *Procedia Engineering*, 2012.
44. Y. Mizutani, H. Sawano, H. Yoshioka, and H. Shinno, "Magnetic fluid seal for linear motion system with gravity compensator," in *Procedia CIRP*, 2015.
45. M. S. Krakov and I. V. Nikiforov, "Regarding the influence of heating and the Soret effect on a magnetic fluid seal," *J. Magn. Mater.*, 2017.
46. Z. Meng, Z. Jibin, and H. Jianhui, "An analysis on the magnetic fluid seal capacity," *J. Magn. Mater.*, 2006.
47. J. Salwiński and W. Horak, "Measurement of Normal Force in Magnetorheological and Ferrofluid Lubricated Bearings," *Key Eng. Mater.*, 2011.
48. D. A. Bompos and P. G. Nikolakopoulos, "Experimental and Analytical Investigations of Dynamic Characteristics of Magnetorheological and Nanomagnetorheological Fluid Film Journal Bearing," *J. Vib. Acoust.*, 2016.
49. I. F. Santos, "On the future of controllable fluid film bearings," in *9th EDF/Pprime (LMS) Poitiers Workshop*, 2010.
50. S. E. Mushi, Z. Lin, and P. E. Allaire, "Design, construction, and modeling of a flexible rotor active magnetic bearing test rig," *IEEE/ASME Trans. Mechatronics*, 2012.
51. H. Montazeri, "Numerical analysis of hydrodynamic journal bearings lubricated with ferrofluid," *Proc. Inst. Mech. Eng. Part JJ. Eng. Tribol.*, 2008.
52. D. A. Bompos and P. G. Nikolakopoulos, "Journal Bearing Stiffness and Damping Coefficients Using Nanomagnetorheological Fluids and Stability Analysis," *J. Tribol.*, 2014.
53. Z. Huang, J. Fang, X. Liu, and B. Han, "Loss Calculation and Thermal Analysis of Rotors Supported by Active Magnetic Bearings for High-Speed Permanent-Magnet Electrical Machines," *IEEE Trans. Ind. Electron.*, 2016.
54. M. L. Chan et al., "Design and characterization of MEMS micromotor supported on low friction liquid bearing," *Sensors Actuators, A Phys.*, 2012.
55. X. Song and H. G. Wood, "Application of CFX to Implantable Rotary Blood Pumps Suspended by Magnetic Bearings," in *International ANSYS Conference*, 2004.
56. D. A. Bompos and P. G. Nikolakopoulos, "CFD simulation of magnetorheological fluid journal bearings," *Simul. Model. Pract. Theory*, 2011.
57. S. Jahanmir et al., "Design of a small centrifugal blood pump with magnetic bearings," *Artif. Organs*, 2009.
58. W. Ochoński, "Sliding bearings lubricated with magnetic fluids," *Industrial Lubrication and Tribology*. 2007.
59. T. M. Lim, S. Cheng, and L. P. Chua, "Parameter estimation and actuator characteristics of hybrid magnetic bearings for axial flow blood pump applications," *Artificial Organs*. 2009.

CONTACT WITH THE AUTHOR

Leszek Matuszewski
e-mail: leszekma@pg.gda.pl

Gdansk University of Technology
Narutowicza 11/12
80-233 Gdansk
POLAND