

Andrzej CIŃCIO¹
Jan FEDOROWICZ²

ANALYSIS OF WALL STRUCTURES SUBJECTED TO MINING DISCONTINUOUS DEFORMATIONS

The paper presents a simplified methodology for the analysis of static building construction longwall when within the horizontal projection of the foundation can find a local threshold or a fault area. It shows the formulation of the basic assumptions of work and provides theoretical considerations leading to the determination of additional load rigid structure located above the gap. Then formulated a way that the separation of the designated load spatial body of the building on each side of the building. The results were confronted with the results of the analyzes of numerical aspects of behavior of buildings on the emerging facet of land in the form of a threshold. Analyzed the structures of rigid construction, constructed in accordance with the principles set out in the guidelines. The analysis was performed by MES with the program Abaqus and the Robot program. It adopted with the assumption that the fault coverage will not exceed the defined work called. critical distance. In the construction of the model surface mining in addition to the model of linear-elastic and model Winkler's used for substrates simplest models of the material elastic-plastic - model of the surface of plasticity in the form of a condition Coulomb-Mohr and Drucker-Prager, and model the mechanics of the critical state of Modified-Cam-Clay.

Keywords: Influences mining, buildings in mining area, numerical analysis, constitutive models of soil, Modified Cam-Clay

1. Introduction

Mining, irrespectively of the pace and depth, always exerts negative impact on the land development. Loads of buildings caused with such impacts differ in character, direction, range of action and frequency of occurrence from loads to which buildings are designed in steady areas. Deforming ground base generally causes creation of additional internal forces in the building, resulting mainly from ground friction against the foundations or its pressure onto vertical elements of the building plunged into soil, influence of various vertical and hori-

¹ Autor do korespondencji/corresponding author: Andrzej Cińcio, Politechnika Śląska, Katedra Teorii Konstrukcji Budowlanych, ul. Akademicka 5, 44-100 Gliwice; andrzej.cincio@polsl.pl

² Jan Fedorowicz, Wyższa Szkoła Techniczna, Wydział Architektury, Budownictwa i Sztuk Stosowanych, ul. Rolna 43, 40-555 Katowice; jankfedorowicz@gmail.com

zontal displacements of the soil and inclination of the land. While considering the problems of housing construction on mining areas one mainly thinks of designing new buildings and adapting such buildings to the expected land deformations already in the designing phase. However, the impact of mining onto the existing buildings is an equally important and broad issue concerning the housing construction on mining areas. Mining of shallowly-seated deposits or intensive mining may cause occurrence of local disorders of land surface continuity in a form of for example thresholds, slits, stepped parts or craters (Fig. 1). Such phenomena affect mainly all land which is unfavourably "geologically conditioned" for example areas of outcrops and natural tectonic subsidence when there is threat that subsequent exploitation will naturally start processes of rock layers sliding or cause flow of underground waters to old excavation sites.

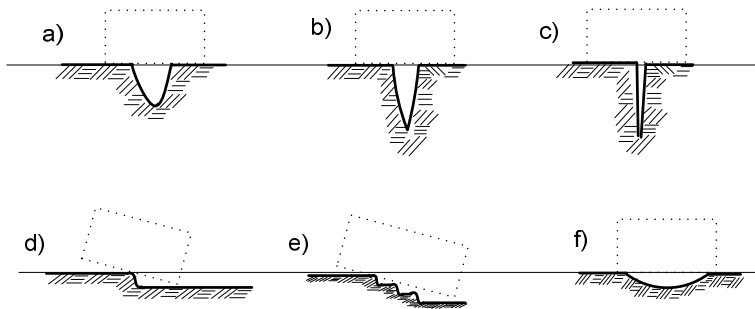

Fig. 1. Types of deformation of the discontinuous surface a) sink hole, b) funnel, c) gap, d) and e) ground braces, f) local sink

Rys. 1. Rodzaje deformacji nieciągłych powierzchni terenu, a) zapadlisko, b) lej, c) szczelina, d) i e) progi, f) zapadlisko lokalne

Taking into account the possibility of protecting the building object against the occurrence of a state threatening the safety of users we have to eliminate catastrophic-like deformations such as craters or landslides of several meters depths. Nevertheless, it seems that such cases were always connected with erroneous exploitation and overexploitation of deposits.

Still, there are some areas where thresholds and stepped parts are the only form of local deformations. They are usually the consequence of subsequent exploitation which as a result of the existing, appropriate geological conditions starts the processes of for example removal of affected rock formations or flow of underground water to old goafs. Then, if there is a risk of creation of stepped parts or thresholds on the surface, running within the reach of buildings location, one must consider the manner of their protection. In Polish literature there are no elaborations dealing with such issue. Some special cases of the impact of discontinuous deformations on specially protected masonry buildings are considered in works [1-5]. Short elaborations appearing from time to time in technical litera-

ture usually refer to the existing specific situations of threat to buildings with land discontinuity and handle the analysis of possibilities to save the endangered building structure and its repair. As an example, work published in 1990 by Sachs [8] mentions only the problem of forecasting possible landslide deformations in the mining areas. The indications concerning the manner of assessing internal forces in buildings founded on areas with discontinuous deformations are included only in Russian [10] and Ukrainian [11] publications.

This work includes a certain, simplified methodology, previously presented in works [1-5], of conducting static analysis of wall-structure buildings in situation when a local threshold or stepped parts can be found within the horizontal projection of their foundations [6] - as shown in Fig. 2. The formulation of basic work assumptions was presented as well as some theoretical considerations were given that allow defining additional loads of a rigid building to be found over the stepped part. Next, the manner of distributing the specified load of building's spatial block onto particular walls of the building was presented.

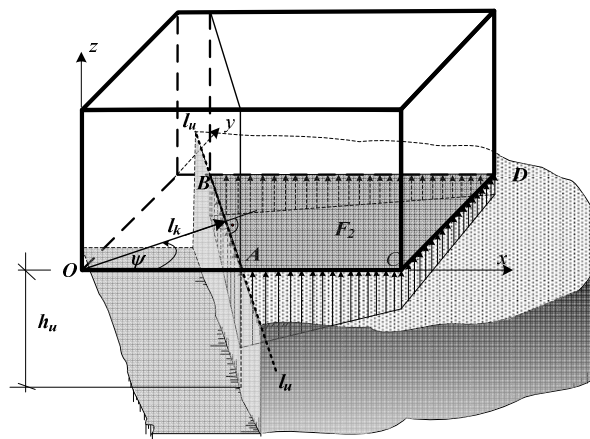

Fig. 2. Scheme of the analyzed case of the building's position on the stepped

Rys. 2. Schemat analizowanego przypadku położenia budynku nad uskokiem

The final part of the work was devoted to the presentation of numeric calculations on FEM models of the structure-subsoil system, both the simplest ones defined with linear and elastic model (e) or with the use of parametric Winkler's base, as well as the advanced ones - physically non-linear where the base was modelled with the use of the following models: Coulomb-Mohr (C-M), Drucker-Prager (D-P) and Modified Cam-Clay (MCC). The received results of numerical calculations in the form of stress diagrams for the structure were compared with values reached on the basis of the presented models. Finally, conclusions were

formed allowing to the use of information included herein when designing the wall structure in conditions of possible occurrence of discontinuous area deformations.

2. Analysis assumptions

The following initial assumptions were considered herein:

- analysis is performed of wall-structure buildings, designed as rigid according to designing guidelines [7,9],
- buildings threatened with occurrence of discontinuous deformations within the horizontal projection such as threshold or stepped part may be protected in a manner enabling to users safe transfer of loads by the structure,
- the direction of edges of possible stepped part (threshold) is defined within the permitted error as a result for example of geological conditions. Real parallel position of stepped part edges has a random character, though. Moreover, it is expected, that the position shall not exceed the so called critical position of the stepped part,
- the subsoil model shall be linear elastic one parameterized with the vertical elasticity coefficient C_o [7, 9].

Numerical analysis herein was conducted with the following assumptions:

- the length of the stepped part edge l_u (Fig. 2) is large enough to analyse the behaviour of subsoil as in the task of the state of the plain strain (PSO),
- the range of the stepped part l_k (Fig. 2) does not exceed the so called "critical value" adopted herein, and the height of the stepped part h_u is sufficient for the part of the building, with the specific value l_k , to "hang" over the stepped part, without the contact with subsoil,
- the structure is modelled as a substitute full block made of linear elastic material (e) in flatwise of the state tensile strength (PSN) or the state of the plain strain (PSO) with specified stiffness defined with the elastic material parameter E_b ,
- in the structure there is analysis of extreme generalized crosscutting forces (bending moments M_{zg} and lateral forces Q_b) indicated on the basis of distribution of horizontal stress state σ_{11} and shear stress σ_{12} (and their change over the structure length) as well as deformation of the structure,
- load of the structure constitutes dead weight and payload (eg. shown in Fig. 2) and in all analyzed cases is assumed as unchanged,
- the appearance of the stepped part in non-linear tasks is modelled through gradual removal of particular finite elements or finite elements groups) in the calculation model during the analysis, in separate incremental step, upon completion of the process of its loading,
- in order to eliminate the impact on internal forces of minor subsoil thrust forces during deformation of the structure in the initial phase of numerical

analysis, firstly, finite elements are removed along vertical sides of the deepened structure.

The applied term: "critical position of the stepped part" shall be understood as the final possible position of the stepped part edge, where the building shall "hang" over the stepped part, without the occurrence of rotation as a rigid block (Fig. 2).

3. Formulation of the problem and its analytical solution

Let's analyze any horizontal projection of the building, described in a global coordinate system (x,y,z) – Fig. 3. Let's assume that the resultant Q of building loads - dead weight and payload is located in point $\Gamma(\Delta_x, \Delta_y)$. Let's assume position of the stepped part edge l_u described with distance l_k from the beginning of the coordinate system (x,y,z) and angle ψ , included between line l_k perpendicular to line l_u and axis Ox . Let the stepped part edge l_u divide the building's horizontal projection area into two parts: F_1 – part deprived of contact with subsoil and F_2 – intermediating in transferring load Q to subsoil.

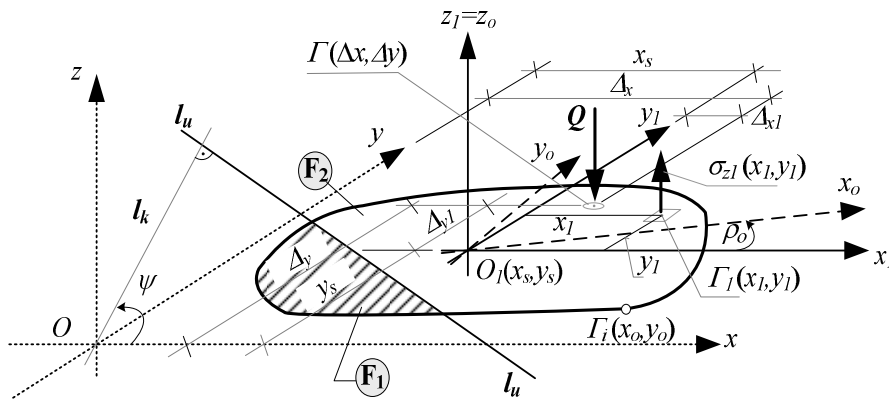

Fig. 3. System of forces load and load balancing operation structure Q

Rys. 3. Układ sił obciążenia i równoważących działanie obciążenia budowli Q

Let's choose any point $O_1(x_s, y_s)$ in part F_2 as the beginning of new coordinate system (x_1, y_1, z_1) parallel to system (x, y, z) . Assuming that the building is a rigid block, the linear elastic impact of subsoil may be approximately described in system (x_1, y_1, z_1) with equation:

$$\sigma_{z_1}(x_1, y_1) = a \cdot x_1 + b \cdot y_1 + c \tag{1}$$

Assuming that the rotation of the building in the placement plane (round axis Oz_l) is marginal and does not have an impact on changing additional building forces, the general conditions of the building - subsoil system balance may be written (Fig. 3):

$$\left. \begin{aligned} \sum M_{x_l} = 0 &\Rightarrow \int_{F_2} y_1 \cdot \sigma_{z_l}(x_1, y_1) \cdot dF_2 = Q \cdot (\Delta_y - y_s) \\ \sum M_{y_l} = 0 &\Rightarrow \int_{F_2} x_1 \cdot \sigma_{z_l}(x_1, y_1) \cdot dF_2 = Q \cdot (\Delta_x - x_s) \\ \sum P_{z_l} = 0 &\Rightarrow \int_{F_2} \sigma_{z_l}(x_1, y_1) \cdot dF_2 = Q \end{aligned} \right\} \quad (2)$$

Based on the analysis of system solution form (2) it results that if point $O_l(x_s, y_s)$ is the centre of gravity of field F_2 , and the coordinate system (x_l, y_l, z_l) covers the main central coordinate system (x_o, y_o, z_o) for the part of foundation projection of field F_2 then solution (2) shall have the following form:

$$\begin{aligned} a &= \frac{Q \cdot \Delta_{x_o}}{J_{y_o}^{(2)}}, \\ b &= \frac{Q \cdot \Delta_{y_o}}{J_{x_o}^{(2)}}, \\ c &= \frac{Q}{F_2} \end{aligned} \quad (3)$$

where:

$J_{x_o}^{(2)}, J_{y_o}^{(2)}$ – the moments of inertia of field F_2 with respect to the main central axis of the coordinate system (x_o, O_l, y_o) ,

$\Delta_{x_o}, \Delta_{y_o}$ – coordinates defining the position of the resultant load Q in the main central coordinate system (x_o, O_l, y_o) .

Then, the equation of the subsoil resistance (1) written in the main central coordinate system (x_o, O_l, y_o) shall have the following form:

$$\sigma_{z_o}(x_o, y_o) = \frac{Q}{F_2} \cdot \left(\frac{x_o}{\left(\frac{J_{y_o}^{(2)}}{F_2 \cdot \Delta_{x_o}} \right)} + \frac{y_o}{\left(\frac{J_{x_o}^{(2)}}{F_2 \cdot \Delta_{y_o}} \right)} + 1 \right) \quad (4)$$

It can be observed that expression (4) has an analogous form to the expression describing the distribution of stress in the cross section of the bar compressed eccentrically. Thus, the expression in the formula bracket (4) defines in the main central coordinate system (x_o, O_I, y_o) the equation of line along which the elastic subsoil resistance $\sigma_{z_o}(x_o, y_o)$ is equal zero.

From the presented solution we reckon that for the set direction ψ of the stepped part, a maximum distance l_k of the stepped part may be defined that corresponds to critical position of the stepped part at which under the building "hanging" over the stepped part the foundation is not detaching from the subsoil yet. Having settled the critical location of the stepped part on the basis of dependencies (4), though, the full load may be indicated of a building treated as a rigid block, resulting from the appearance of the stepped part. Distributing, on the basis of balance conditions, the indicated load of the building onto particular walls we can define load of each wall independently.

4. Example illustrating indication of forces in the building located over the stepped part

Let's analyze any horizontal projection of the building, described in a global coordinate system (x, y, z) – Fig. 3. Let's assume that the resultant Q of building loads - dead weight and payload is located in point $\Gamma(\Delta_x, \Delta_y)$. Let's assume position of the stepped part edge l_u described with distance l_k from the beginning of the coordinate system (x, y, z) and angle ψ , included between line l_k perpendicular to line l_u and axis Ox . Let the stepped part edge l_u divide the building's horizontal projection area into two parts: F_1 – part deprived of contact with subsoil and F_2 – intermediating in transferring load Q to subsoil.

We indicate load of building created of four walls with geometry shown in Fig. 4 at occurrence of the stepped part of value l_k critical at angle $\psi=0^\circ$. For calculations, the average pressure of building's foundations onto ground was assumed at the level $\sigma_z=100 \text{ kPa}$. With the given foundations projection geometry the vertical elasticity coefficient in acc. with [7, 9] is constant and amounts to $C_o=0.72E_o$ where E_o – primary ground deformation module, and the corrected horizontal projection of foundations is identical to the actual projection.

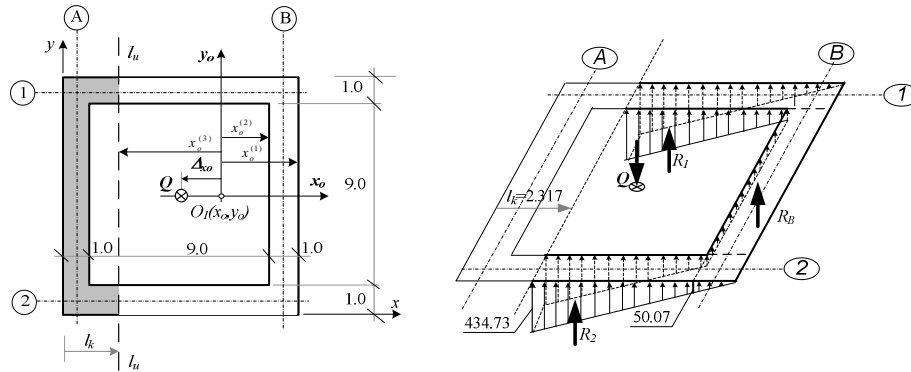

Fig. 4. Scheme of horizontal projection and calculated load of the building

Rys. 4. Schemat rzutu poziomego i wyznaczone obciążenie budynku

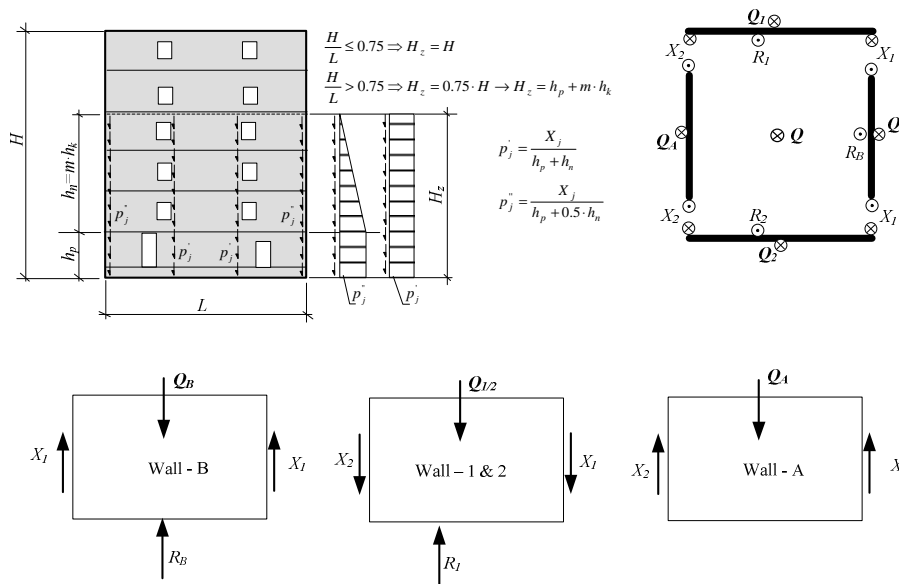

Fig. 5. Distribution of mining load on individual walls of a building

Rys. 5. Rozdział obciążenia górniczego na poszczególne ściany budynku

Next, having divided the analysed 3D spatial arrangement into particular walls (Fig. 5), from the balance conditions we receive loads of particular walls amounting to: $Q_1 = Q_2 = 1100 \text{ kN}$, $Q_A = Q_B = 900 \text{ kN}$, $X_1 = 337.34 \text{ kN}$, $X_2 = 450 \text{ kN}$. In the detailed analysis of particular building walls the indicated loads X_i , depending on the particular walls measurements proportions and intensity of perforation with window or door openings, may be distributed in height for example in a manner suggested in [7, 9]. The details of such distribution are shown in Fig. 5.

5. Numerical model of the structure - subsoil and chosen analysis results

The building loads indicated in the previous chapter were compared with values achieved in numerical analysis with the use of FEM and elastic and non-elastic subsoil models.

The geometry of the calculation model was shown in Fig. 6. The calculation model was built through placing a discrete FEM grid composed of square and triangular elements, concentrated in areas of expected increased component gradients of the stress condition.

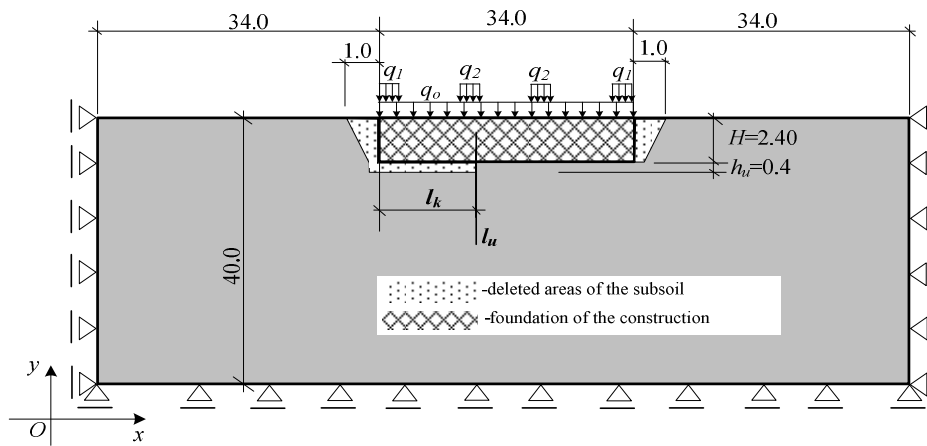

Fig. 6. The geometry of the numerical model of the construction-subsoil

Rys. 6. Geometria modelu obliczeniowego układu budowla-podłoże gruntowe

The character of the discrete grid was shown in Fig. 7. There, on subsequent model fragments: s-1, s-2, s-3, s-4 the simulation course was schematically shown how the landslide appears under the structure in the calculation model. The building was modelled as uniform block of height $H=2.0m$, described with elastic material of parameters $E_b=3.4 \cdot 10^7 \text{ kPa}$ and $\nu=0.167$. The structure model load was assumed on the basis of actual engineering design equal to: $q_0=158 \text{ kN/m}^2$, $q_1=140.1 \text{ kN/m}^2$, $q_2=62.3 \text{ kN/m}^2$ and the specific gravity of the structure material was assumed $\gamma=25 \text{ kN/m}^3$.

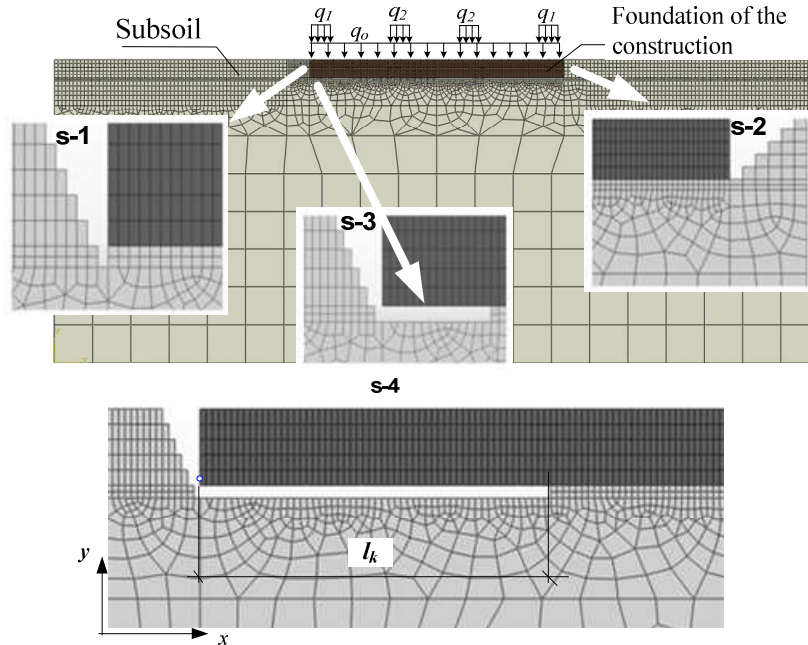

Fig. 7. Discrete mesh and the order of the removal of finite element in the simulation of the formation of landslides

Rys. 7. Siatka modelu obliczeniowego oraz kolejność usuwania elementów skończonych w symulacji powstawania usuwiska

As mentioned in the introduction, the subsoil was modelled with the use of different constitutive models, apart from the linear elastic one (e), also non-linear: Coulomb-Mohr (C-M), Drucker-Prager (D-P) and Modified Cam-Clay (MCC). The values of material parameters adopted in the analysis as well as designations of particular model are included in table 1. In calculations it was assumed that the mining area stepped part will take place in the distance $l_k=11.2m$ – Fig. 6.

In the following Figures 8 to 10, the distribution of horizontal stress was presented achieved in numerical calculations in the upper extreme horizontal cross-section of the building for particular variants of the model differing in the adopted material models, in comparison to the analytical solution. Designations identifying particular curves of diagrams are included in tab. 1

On the basis of achieved results of numerical analyses it may be assumed that the building stress may be estimated on the basis of the suggested analytical method to solve the problem if the achieved results based on (4) are reduced by about 15-25% which corresponds to values of all internal forces, displacements and deformations multiplied by the reduction coefficient $\alpha=(0.75\div 0.85)$ – as shown in Fig. 8 to 10.

Table 1. Accepted material parameters used for constitutive models of the subsoil

Tabela 1. Przyjęte parametry materiałowe dla zastosowanych modeli konstytutywnych podłoża gruntowego

Marking on fig. 8-10	Subsoil model	$\phi [^\circ]$	$c [kPa]$	$l_k [m]$	ν	$E_{bud} [kPa]$	$E_{gr} [MPa]$
(e)-a	(e)	Solution of the cantilever length $l_k=8.60 m$ or $l_k=11.20 m$ subjected to distributed load q_0, q_1 i q_2 from fig. 6.					
(e)-b	(e)	Solution of the rigid beam loaded of subsoil reactions according to (4) for $l_k=11.20 m$ and distributed load: q_0, q_1 i q_2 from fig. 6.					
(e)-1	(e)	-	-	11.20	0.30	$3.24 \cdot 10^7$	20
(e)-2	(e)	-	-				50
(e)-3	(e)	-	-				100
(D-P)-1	(D-P)	30	5				50
(D-P)-2	(D-P)	40	5				50
(D-P)-3	(D-P)	30	5				100
(D-P)-4	(D-P)	40	5				100
(C-M)-18	(C-M)	20	50				20
(C-M)-19	(C-M)	20	100				20
(C-M)-20	(C-M)	40	5				50
(C-M)-21	(C-M)	20	50	60			
(C-M)-22	(C-M)	20	100	60			
(C-M)-23	(C-M)	40	5	100			
(mcc)-5	(MCC)	30	$e_{cs}=1.788, \kappa=0.0074, \lambda=0.066, M=1.2, K_o^{(NC)}=1-\sin(\phi^i),$	11.20	0.30	$q^*=50 kPa, K_o^{(OC)}$ - according to Wroth's eq. , $\gamma=20 kN/m^3,$	

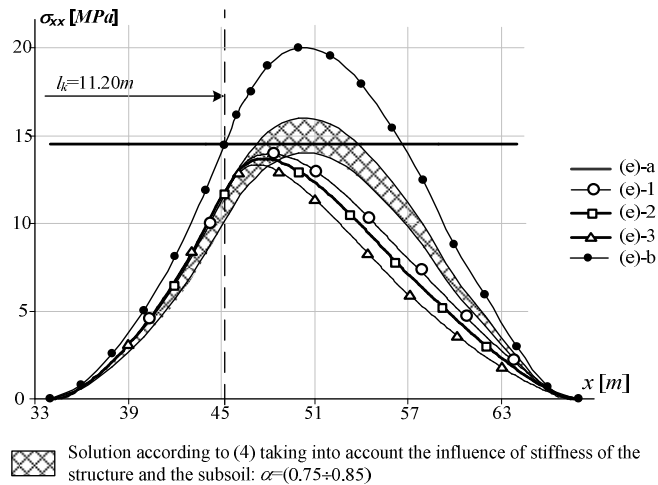

Fig. 8. Subsoil model (e), $l_k=11.2m$ – change the horizontal normal stress in the upper end horizontal section through the building

Rys. 8. Model podłoża (e), $l_k = 11.2m$ – zmiana poziomego naprężenia normalnego w górnym skrajnym poziomym przekroju przez budowlę

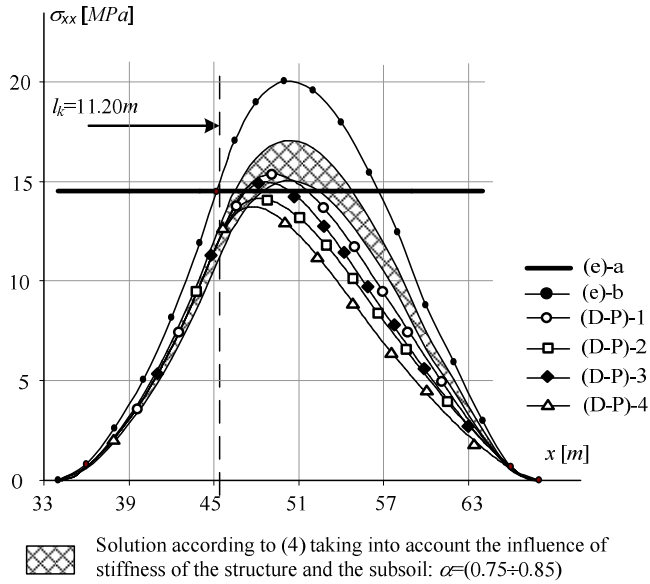

Fig. 9. Subsoil model (D-P), $l_k = 11.2m$ – change the horizontal normal stress in the upper end horizontal section through the building

Rys. 9. Model (D-P), $l_k = 11.2m$ – zmiana poziomego naprężenia normalnego w górnym skrajnym poziomym przekroju przez budowlę

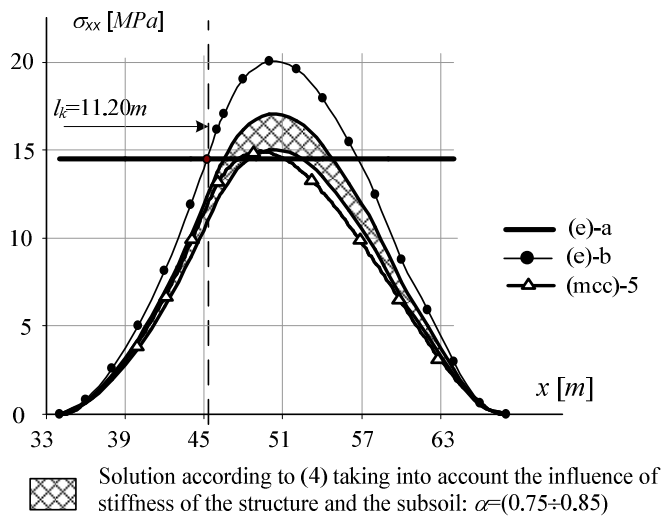

Fig. 10. Subsoil model (MCC), $l_k = 11.2m$ – change the horizontal normal stress in the upper end horizontal section through the building

Rys. 10. Model (MCC), $l_k = 11.2m$ – zmiana poziomego naprężenia normalnego w górnym skrajnym poziomym przekroju przez budowlę

6. Numerical model of the structure on elastic parametric subsoil and chosen analysis results

The last model presented in the work is a simplified, engineering model of the analysed structure in which the subsoil is represented with a parametric linear elastic Winkler's model (Fig. 11) of several different stiffnesses resulting from the adopted ground deformation modules specified in Fig. 12. The calculations were made in FEM with the use of program Robot.

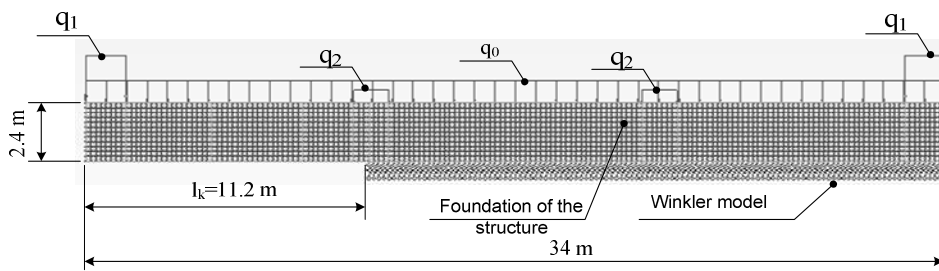

Fig. 11. Diagram of a simplified FEM model in the program ROBOT
 Rys. 11. Schemat uproszczonego modelu MES w programie ROBOT

Figure 12 presents the numerical calculation-based distribution of horizontal stress in upper fibres of the analyzed wall for length of the stepped part $l_k=11.2m$ and for different parameters of subsoil stiffness.

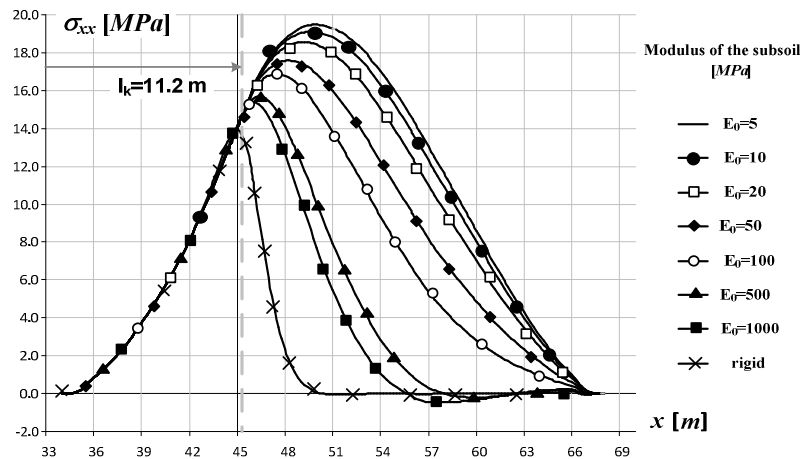

Fig. 12. Winkler subsoil model - change the horizontal normal stress in the upper end horizontal section through the building

Rys. 12. Model podłoża Winklera – zmiana poziomego naprężenia normalnego w górnym skrajnym poziomym przekroju przez budowlę

7. Summary

Following the analysis of achieved results, it stems out that the values of horizontal normal stress received on the basis of a solution of the building treated as a rigid block (analytical solution) are greater than the values received on the basis of numerical solutions by about 10-25%. Nevertheless, the values of horizontal normal stress indicated on the basis of elementary support diagram of the building are lower from the proper values resulting from the numerical calculations.

On the basis of the analysis of values of internal forces for the elastic solution it results that the stiffness adopted in the calculations of the elements representing the building, compared to the ground stiffness is so large that its further increasing does not significantly change the solution (Fig. 8). It may also be observed that stress of the building changes for the adopted subsoil model depending on the value of its material parameters only in the defined, slight scope.

Lower values of normal stress achieved in numerical analyses may be interpreted as a result of more accurate model both of the structure as well as the ground model, additionally considering in the second case the inelastic properties of the subsoil.

Acknowledgement

Numerical analyses were performed at ACK CYFRONET AGH Kraków, based on grant MNiSW/SGI3700/PŚląska/054/2010 and MNiSW/SGI3-700/PŚląska/056/2010.

References

- [1] Cińcio A., Fedorowicz J., Ruszel B.: Wall-buildings in mining areas of the discontinuous deformations. Part I – theoretical discussion, Proceedings of the 10th International Conference on New Trends in Statics and Dynamics of Buildings, 3-5 October 2012, Bratislava, p. 17-20.
- [2] Cińcio A., Fedorowicz J., Ruszel B.: Wall-buildings in mining areas of the discontinuous deformations. Part II – numerical analyses, Proceedings of the 10th International Conference on New Trends in Statics and Dynamics of Buildings, 3-5 October 2012, Bratislava, p. 21-24.
- [3] Fedorowicz L., Fedorowicz J., Cińcio A.: Metoda analizy statycznej ścian budynków mieszkalnych na terenach górniczych o deformacjach nieciągłych. Bezpieczeństwo Pracy i Ochrona Środowiska w Górnictwie nr 1, 1995, s. 36-40.
- [4] Fedorowicz L., Fedorowicz J.: Analiza wyężenia wzmocnienia gorsetowego budynków murowanych na terenach górniczych o deformacjach nieciągłych. Zeszyty Naukowe Pol. Śl. Gliwice, seria Budownictwo, z. 84, 1997.
- [5] Fedorowicz L., Fedorowicz J.: Obliczanie budynków mieszkalnych zagrożonych awarią na terenach górniczych o deformacjach nieciągłych. Materiały Naukowo – Technicznej Konferencji „Awarie Budowlane”, Szczecin-Międzyzdroje, maj 1994, t. 2, s. 455÷461.

- [6] Ledwoń J. A.: Budownictwo na terenach górniczych. Arkady, Warszawa 1983.
- [7] Projektowanie budynków na terenach górniczych. Instrukcje, Wytyczne, Poradniki, 416/2006. Wydawnictwo ITB, Warszawa 2006.
- [8] Sachs J.: Prognozowanie deformacji zapadliskowych na terenach górniczych z uwzględnieniem badań geofizycznych. Wydawnictwo ITB, Warszawa 1990.
- [9] Wytyczne projektowania budynków o ścianowym układzie nośnym podlegających wpływowi eksploatacji górniczej. Instrukcja 286. Wydawnictwo ITB, Warszawa 1988.
- [10] Методические указания по проектированию мер защиты эксплуатируемых зданий и сооружений в районах залегания крутопадающих пластов. ВНУМУ, Ленинград 1973.
- [11] Указания по проектированию бескаркасных зданий в центральном районе донбаса на площадях залегания крутопадающих угловых пластов. РСН-227-71. ГКСМ УССР по делам строительства, Донецк 1071.

ANALIZA KONSTRUKCJI ŚCIANOWYCH NARAŻONYCH NA WPŁYW NIECIĄGŁYCH DEFORMACJI GÓRNICZYCH

Streszczenie

W pracy przedstawiono uproszczoną metodykę przeprowadzania analizy statycznej budynków o konstrukcji ścianowej w sytuacji, gdy w obrębie rzutu poziomego ich fundamentów może znaleźć się lokalny próg lub uskok terenu. Przedstawiono sformułowanie podstawowych założeń pracy oraz podano rozważania teoretyczne prowadzące do określania dodatkowego obciążenia budowli sztywnej znajdującej się nad uskokiem. Następnie sformułowano sposób pozwalający na rozdzielenie wyznaczonego obciążenia przestrzennej bryły budynku na poszczególne ściany budynku. Uzyskane rezultaty skonfrontowano z wynikami przeprowadzonych analiz numerycznych zagadnienia zachowania się budowli nad powstającym uskokiem terenu w postaci progu. Analizie poddano budowlę o konstrukcji sztywnej, skonstruowane zgodnie z zasadami podanymi w wytycznych. Analizę przeprowadzono metodą MES przy pomocy programu Abaqus oraz programu Robot. Przyjęto przy tym założenie, że zasięg uskoku nie przekroczy zdefiniowanej w pracy tzw. odległości krytycznej. W budowie modelu podłoża górniczego oprócz modelu liniowo-sprężystego oraz modelu Winklera wykorzystano dla podłoża najprostsze modele materiału sprężysto-plastycznego – model z powierzchnią plastyczności w postaci warunku Coulomba-Mohra oraz Druckera-Pragera, a także model mechaniki stanu krytycznego Modified-Cam-Clay.

Słowa kluczowe: wpływy górnicze, budynki na terenie górniczym, analizy numeryczne, modele konstytutywne gruntu, Modified Cam-Clay

Przesłano do redakcji: 20.02.2017 r

Przyjęto do druku: 28.04.2017 r.

