

PIOTR CHELUSZKA*#

EXCAVATION OF A LAYERED ROCK MASS WITH THE USE OF TRANSVERSE CUTTING HEADS OF A ROADHEADER IN THE LIGHT OF COMPUTER STUDIES**URABIANIE GÓROTWORU O BUDOWIE WARSTWOWEJ GŁOWICAMI POPRZECZNYMI KOMBAJNU CHODNIKOWEGO W ŚWIETLE BADAŃ SYMULACYJNYCH**

Rock excavation is a basic technological operation during tunnelling and drilling roadways in underground mines. Tunnels and roadways in underground mines are driven into a rock mass, which in the particular case of sedimentary rocks, often have a layered structure and complicated tectonics. For this reason, rock strata often have highly differentiated mechanical properties, diverse deposition patterns and varied thicknesses in the cross sections of such headings. In the field of roadheader technology applied to drilling headings, the structure of a rock mass is highly relevant when selecting the appropriate cutting method for the heading face. Decidedly differentiated values of the parameters which describe the mechanical properties of a particular rock layer deposited in the cross section of the drilled tunnel heading will influence the value and character of the load on the cutting system, generated by the cutting process, power demand, efficiency and energy consumption of the cutting process. The article presents a mathematical modelling process for cutting a layered structure rock mass with the transverse head of a boom-type roadheader. The assumption was made that the rock mass being cut consists of a certain number of rock layers with predefined mechanical properties, a specific thickness and deposition pattern. The mathematical model created was executed through a computer programme. It was used for analysing the impact deposition patterns of rock layers with varied mechanical properties, have on the amount of cutting power consumed and load placed on a roadheader cutting system. The article presents an example of the results attained from computer simulations. They indicate that variations in the properties of the rock cut – as cutting heads are moving along the surface of the heading face – may have, apart from multiple other factors, a significant impact on the value of the power consumed by the cutting process.

Keywords: mathematical modelling, computer simulations, roadheader, excavation, rock mass with layered structure

Urabianie skał jest podstawową operacją technologiczną podczas drążenia tuneli oraz wyrobisk korytarzowych w kopalniach podziemnych. Tunele w budownictwie inżynieryjnym oraz wyrobiska korytarzowe w kopalniach podziemnych drążone są w górotworze, który szczególnie w przypadku skał osadowych ma

* SILESIA UNIVERSITY OF TECHNOLOGY, FACULTY OF MINING AND GEOLOGY, DEPARTMENT OF MINING MECHANISATION AND ROBOTISATION, 2 AKADEMICKA STR., 44-100 GLIWICE, POLAND

Corresponding author:

budowę warstwową o niejednokrotnie tektonice. Stąd, w przekroju poprzecznym tego rodzaju wyrobisk występują warstwy skalne o niejednokrotnie silnie zróżnicowanych własnościach mechanicznych, różnym sposobie zalegania oraz miąższości. W technologii kombajnowej budowa górotworu ma istotne znaczenie ze względu na odpowiedni dobór sposobu urabiania powierzchni czoła przodku. Duże zróżnicowanie wartości parametrów opisujących własności mechaniczne poszczególnych warstw skalnych zalegających w przekroju poprzecznym drążonego tunelu czy wyrobiska korytarzowego wpływać będzie przy tym istotnie na wielkość i charakter obciążenia dynamicznego układu urabiania generowanego procesem urabiania, zapotrzebowanie mocy, wydajność i energochłonność urabiania. W artykule omówiono sposób modelowania matematycznego procesu urabiania górotworu o budowie warstwowej głowicą poprzeczną wysięgnikowego kombajnu chodnikowego. Założono, iż urabiany masyw skalny złożony jest z pewnej liczby warstw skalnych o zadanych własnościach mechanicznych, określonej miąższości oraz sposobie zalegania. Utworzony model matematyczny zaimplementowany został w programie komputerowym. Wykorzystany on został do analizy wpływu sposobu zalegania warstw skalnych o zróżnicowanych własnościach mechanicznych na przebieg obciążenia układu urabiania kombajnu chodnikowego oraz moc zużywaną na urabianie. W artykule zaprezentowano przykładowe wyniki symulacji komputerowych. Wskazują one na to, iż zmienność własności urabianych skał w miarę przemieszczania się głowic urabiających po powierzchni czoła przodku, obok wielu innych czynników może mieć silny wpływ na wielkość mocy zużywanej do realizacji procesu urabiania.

Słowa kluczowe: modelowanie matematyczne, kombajn chodnikowy, proces urabiania, górotwór o budowie warstwowej, symulacje komputerowe

1. Introduction

Rock excavation is the principal operation in tunneling in underground mining and civil engineering. Due to this reason, the geological structure of the rock mass including the type of rock, its physiochemical properties, and deposition pattern are critical in selecting the driving technology and machinery for tunneling. Civil engineering tunnels and tunnels for underground mines – driven to open up and prepare a deposit for extraction – are made up of rocks of varying origin (magmatic, sedimentary, or metamorphic rocks). Rock mass, especially in case of sedimentary rock, has a layered structure with complicated tectonics, and the layers have different, often variable thicknesses, diverse deposition patterns, and highly differentiated mechanical properties; for example, layers of rocks with high workability are separated by layers of rocks with low workability (workability of rocks is defined as the resistance to break (Galperin et al., 1993)). Relative to the roof surface of a driven tunnel, the layers of rock may either run parallel or diagonal (Fig. 1).

In underground mining and tunneling projects, rock, for designing a tunnel construction or for selecting a driving technology, can be classified based on its geomechanical properties. The uniaxial compressive strength of rock is one of the key criteria in such classifications (Chen & Liu, 2007). This parameter, apart from abrasivity, characterizes its workability for the selected rock excavation method (mechanical excavation or blasting technology). Roadheaders are excavation machines that can excavate soft to medium strength rocks of sedimentary type. In roadheader technology, the values of the parameters characterizing a rock's workability sets the basis for predicting the energy required by the roadheader, its efficiency, and the energy consumed by the excavation process, which is a performance indicator (Ebrahimabadi et al., 2011; Avunduk et al., 2014).

The earth's crust is made up of rocks with disparate workability, even in the same petrographic group. In relation to mechanical processes, rocks with a uniaxial compressive strength of up to 50 MPa can be classified as weak to medium strong (Peng & Zhang, 2007). Among the

a)

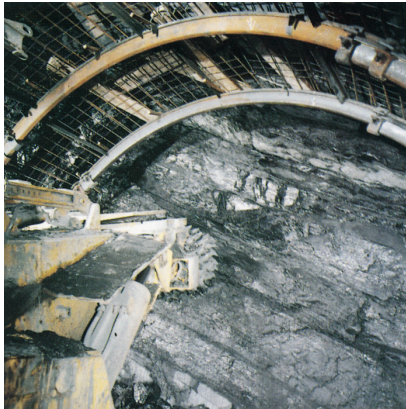

b)



c)

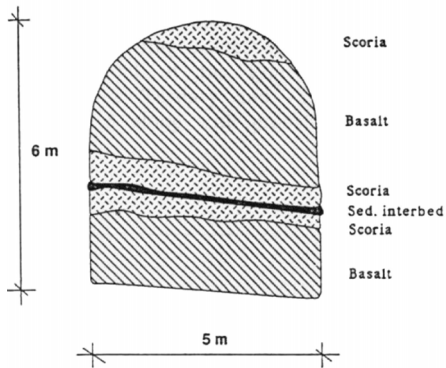

Properties	Basalt	Scoria	Sed. Rock Fine grained	Sed. Rock Coarse grained	Fault Breccias
UCS [MPa]	100–300	10–50	5–30	5–80	1–20
Q-value [NGI]	5–15	3–10	0.1–3	0.5–4	0.01
Drillability [DRI]	Very low – med.	High	High	Med.	High
Abrasiveness [BW]	Low – med.	Low	Low	Low	Low
Young's moduluj, E [GPa]	20–60	2–20	2–10	2–15	–
Typical strata thickness [m]	4–15	0.5–4	0.2–5	1–10	0.1–2

Fig. 1. Examples of layered structure of rock mass within the heading of the excavated tunnels in underground mining and tunneling: (a) in a coal mine (Weber Mining, 2015), (b) basalt layers with sediment interbed (Hjálmarsson, 2011), and (c) mixed heading from Faskrudsfjordur tunnel (Gunnarsson, 2008)

sedimentary rocks, useful minerals are also found such as hard coal, rock salt and potash, gypsum or chalk, and waste rocks with different petrography: claystones, shales, mudstones, and some siltstones can be classified as such rocks. Sandstones, limestones, or dolomites can be considered as stones with low workability though. Compressive strength of such types of rocks may reach, and even exceed, 150 MPa (they are classified as strong to very strong (Peng & Zhang, 2007)). Compressive strength for magmatic and metamorphic rocks may exceed 200, even up to 300 MPa (basalt, granite, gabbro, gneiss, marble, or quartzite). Therefore, rock is considered as having low workability (designated as very strong to extremely strong (Peng & Zhang, 2007)). Therefore, tunneling of such rocks is, usually, conducted with the help of blasting technology because the efficiency of mechanical excavation would be low, making it economically impractical, and even technically impossible. Due to their geologic structure, workability of rock mass in the area of the heading of a tunnel being driven is often strongly diversified (see Table in Fig. 1c). This depends on the type and proportion of the rocks that are deposited in the cross section of the heading and

on the variability of the mechanical properties of rocks throughout its length. In such situations, a driving process can be performed through mixed technology – rocks with high workability can be excavated with a roadheader and those with low workability can be excavated with blasting technology. This allows for the careful selection of rocks from layers of useful minerals and waste rock during the mining process.

Roadheaders (Fig. 2) are widely used machines intended for the mechanized excavation of tunnels in underground mining as well as to a certain extent in civil engineering. In case of excavation to form the heading, the cutting process is performed with picks mounted in holders arranged along the side of the cutting head. A drive incorporated in the boom creates the rotary motion of the cutting head. Such roadheaders may be equipped with two transverse heads (Fig. 2a), or optionally, with a longitudinal head (Fig. 2b). The axis of rotation of the transverse cutting heads is perpendicular to the longitudinal axis of the boom they are mounted on. In turn, the axis of rotation of the longitudinal cutting head coincides with the longitudinal axis of the boom. Because of the small dimensions of the cutting heads relative to the cross section of the excavated tunnel, the heads move along the surface of the heading because of the deflection of the boom. The boom deflection takes place on a plane parallel or perpendicular to the floor. Thus, the range of the boom deflection determines the shape and dimension of the tunnel's cross section. In case of the referred roadheaders, a layered structure of rock mass and the workability of the rocks making up these layers have an effect on the excavation technology for the heading, as well as on the values of the parameters resulting from the process being performed: the web z , the height of cut h , the angular speed of cutting heads $\dot{\varphi}_G$, and the movement speed of cutting heads v_{OW} (Fig. 3). Web z (section \overline{AB}) is equal to the distance from the tip vertex of pick distributed on the largest diameter of the cutting head (D_{\max}) from the surface of the heading, measured along the AT straight line.

This straight line is at the same time the intersection line:

- of a plane defined by the longitudinal axis of the boom and its axis of rotation (this plane is deviated from the floor by angle α_V) and
- a plane perpendicular to the floor, passing through point A and axis of rotation of the turntable (axis Z_K).

a)



b)



Fig. 2. Roadheaders equipped with: (a) transverse cutting heads (Famur, 2015) and (b) longitudinal cutting heads (Sanyhe, 2015)

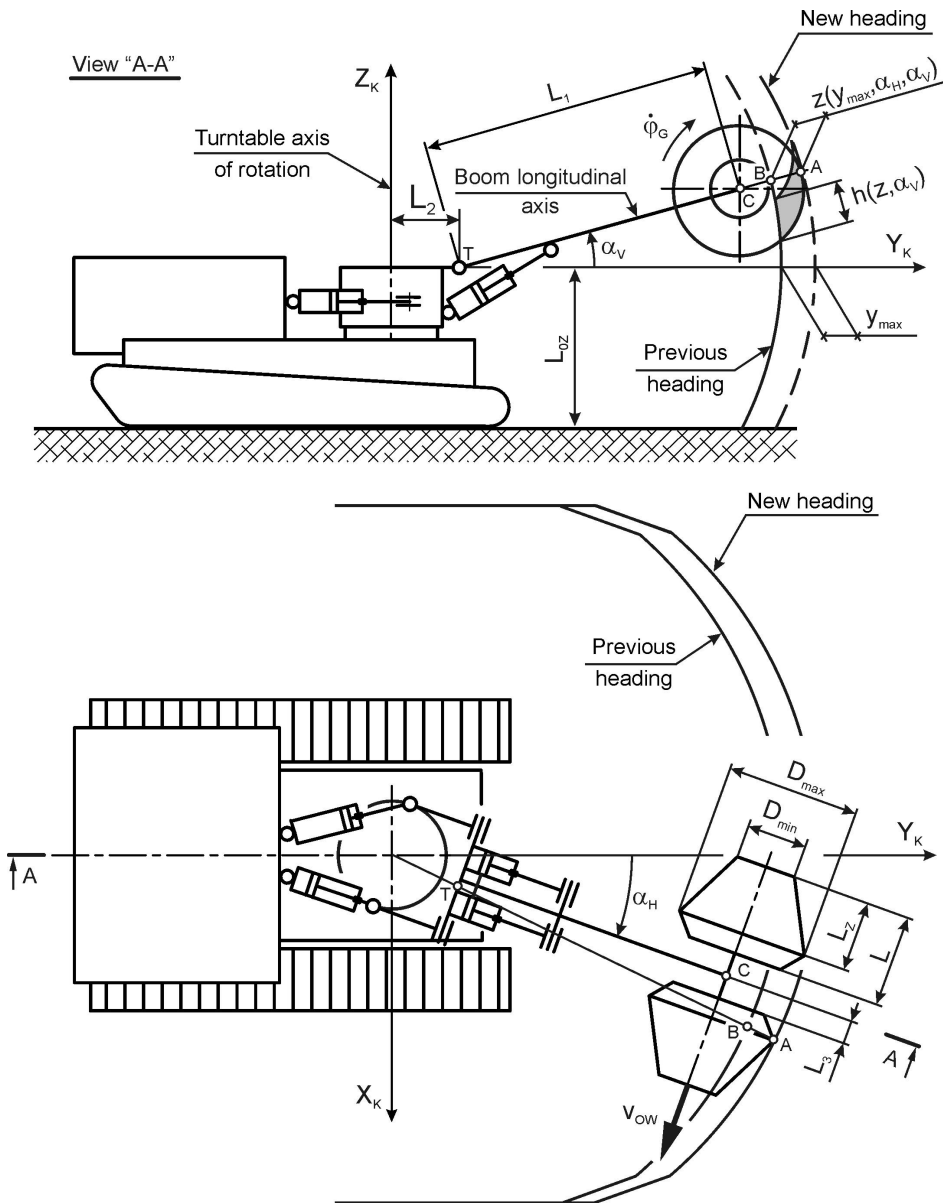

Fig. 3. Operational parameters and basic geometric parameters of the cutting system of the roadheader equipped with transverse cutting heads

The height of cut h is equal to the movement of the cutting heads in a plane perpendicular to the floor at the transition to performing the subsequent cut parallel to the floor. This height is measured in the plane determined by the axis of rotation of the turntable (axis Z_K) and point A, in the direction perpendicular to straight line AT. Whereas the velocity of the cutting heads'

movement v_{OW} is the circumferential speed of the boom swing at the point of intersection of the longitudinal axis of the boom with the axis of rotation of the cutting heads (point C). Such parameters, in conjunction with the mechanical properties of the rock cut, are the basic factors that impact the dynamic load value on the roadheader cutting system, the cutting efficiency achieved, and the energy consumed during the excavation process (Dolipski & Cheluszka, 1999; Fries et al., 2014). In more commonly used roadheader cutting technology, this process is carried out on cuts parallel to the floor (Heiniö, 1999; Jonak & Rogala-Rojek, 2012; Knissel & Wiese, 1981; Sikora, 2000) (Fig. 4). When the cross section of rock layers from the heading are not deposited parallel to the floor, the cutting heads pass through layers with varying workability. Consequently, the picks in contact with the workable rock are subject to variable loads, caused by the changing mechanical properties of the excavated rock being cut. When a cutting head is being moved from one tunnel sidewall to another, varying properties of the excavated rock may, additionally, be a significant factor of influence on the level and character of load applied to the cutting heads of the roadheader, their drive, and boom.

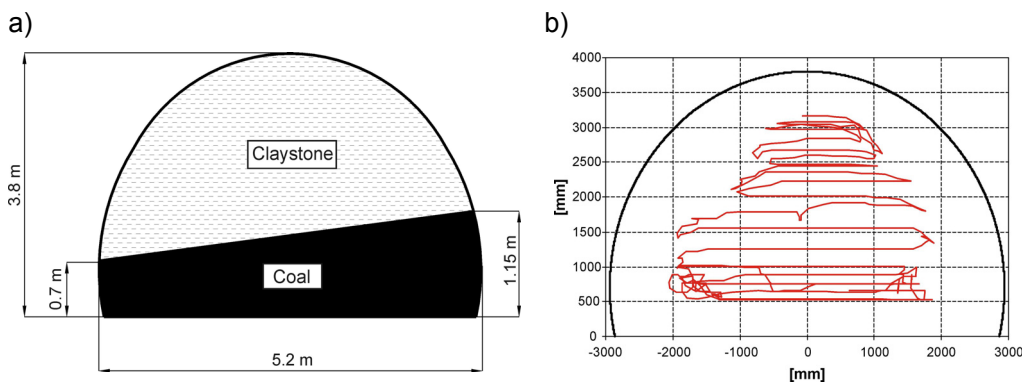

Fig. 4. Example of geological structure of rock mass in the cross section of the driven tunnel (a) and the actual movement trajectory of transverse cutting heads during heading excavation (b) (Sikora, 2000)

The excavation of isotropic or anisotropic rocks with determined constant properties was examined in the simulations undertaken to date (e.g., Jamie, 2011; Knissel & Wiese, 1981; Li et al., 2012; Rojek, 2007; Sun & Li, 2014; Wiese, 1982). In this article, we address the issue of mathematically modeling an excavation process which utilizes the transverse cutting head of a roadheader – applied to a rock mass with a layered structure, consisting of a certain number of rock layers with predefined mechanical properties, a specific thickness, and deposition pattern. At this point cutting rock in the time of boom movement parallel to the floor is considered. It is the main working movement in the classic heading being cut with the use of a roadheader with transverse cutting heads. The developed mathematical model was executed in a computer program which enabled the simulation of the excavation of a rock mass with a layered structure. Through this model, it is possible to obtain inter alia, the load patterns of the cutting heads and the boom of the roadheader. This load is treated as forcing vibrations in the dynamic model of the roadheader, developed specially for examining the dynamics of such machines. The simulation of the cutting process is performed for a full rotation of the cutting heads at fixed (set) parameter

values of this process, at a given rotation of the cutting heads. Changes in the values of the cutting process parameters resulting from the reaction of the roadheader resulting from its dynamic properties (in particular, the elasticity of the elements of the cutting heads' drive, the boom, and its swinging mechanisms) are taken into consideration in the subsequent rotations of the cutting heads. Values of the parameters for which the subsequent simulation is made are corrected accordingly. Thus, the simulation created helps to analyze the impact of the deposition pattern of rock layers with varied mechanical properties on loads of the roadheader cutting system and energy consumption during excavation. The selected results of the numerical analysis have been presented in this work.

2. Modeling of a layered structure of rock mass for simulating the heading surface excavation process

For modeling an excavation process of rock mass with a layered structure, we assumed that n_{WS} rock layers are deposited in the cross section of the tunnel being excavated with a height of h_j^{WS} measured along the symmetrical axis of the heading cross section (axis Z_{WS} – Fig. 5) (for $j = 1, 2, \dots, n_{WS}$). The planes separating the individual layers are inclined toward the intersecting edge of the floor surface with the heading (axis X_{WS}) at an angle of α_j^{WS} . The value of this angle can be either positive or negative. A positive value means the lifting of the plane limiting the given layer from the top toward the right tunnel sidewall and a negative value means the dip of a layer toward this sidewall. Depending on the assumed values of the angle α_j^{WS} , the planes separating the particular rock layers can either be parallel or not. In this the variability of (or the lack of) thickness of particular rock layers within the heading surface of the excavated tunnel is modeled. Types of rocks forming particular layers and the mechanical properties of the rock within the area of each of the separated layers is characterized by a number of parameters. Following should be considered as basic parameters describing the mechanical properties of rocks, which are significant in terms of the course of the excavation process (Frenyo & Lange, 1993; Wiese, 1982):

- uniaxial compressive strength σ_{Cj}^{WS} ;
- the brittleness factor K_{Pj}^{WS} – defined as a ratio of uniaxial compressive strength of rock to uniaxial tensile strength (σ_C/σ_T);
- rib breaking factor f_{Rj}^{WS} – decisive for the possibility of performing relieved cuts (defined as a ratio of maximum spacing between the adjoining cuts at which the self-detachment of the rock occurs between cuts to the depth of the considered cut);
- the breakout angle θ_j^{WS} – determining the inclination of the side surfaces of the cut created as a result of self-detachment of rock grains;

for $j = 1, 2, \dots, n_{WS}$.

As the cutting head moves parallel to the floor, the pick vertexes move along the helixes referred to along the surface of the side of the torus. While observing movement of the vertex of the i -th pick (point S_i) on the plane $X_{WS}Z_{WS}$, it is possible to observe the variations in the values of the coordinates $x_{S_i}^W$ and $z_{S_i}^W$ which describe its position (Fig. 5). The values of these coordinates are expressed using the following equations for the set value of the boom deflection angles on

the planes parallel and perpendicular to the floor: α_H and α_V and the current value of the cutting head rotation angle φ_G (Figs. 6 and 7):

$$\begin{cases} x_{Si}^W = [L_1 \cdot \cos \alpha_V + L_2 + r_i \cdot \cos(\varphi_G - \gamma_i)] \cdot \sin \alpha_H \pm (L_3 + l_i) \cdot \cos \alpha_H \pm \varphi_G \cdot \frac{v_{OW}}{\dot{\varphi}_G} \\ z_{Si}^W = L_{0Z} + L_1 \cdot \sin \alpha_V - r_i \cdot \sin(\varphi_G - \gamma_i) \end{cases} \quad (1)$$

where,

- r_i, l_i, γ_i — coordinates of the vertex of the i -th pick (point S) in the cylindrical system (Figs. 6 and 7);
- L_{0Z}, L_1, L_2, L_3 — geometrical parameters of the roadheader boom and turntable (Fig. 3);
- φ_G — current value of the cutting head rotation angle;
- $\dot{\varphi}_G, v_{OW}$ — respectively, cutting heads angular speed and cutting heads movement speed parallel to the floor;
- α_H — boom deflection angle on the plane parallel to the floor;
- α_V — boom deflection angle on the plane perpendicular to the floor, determined by the height measured from the floor at which the excavation process is carried out.

The “+” sign in equation (1) refers to the right cutting head during cutting toward the right, and the “-” sign refers to the left cutting head during cutting toward the left.

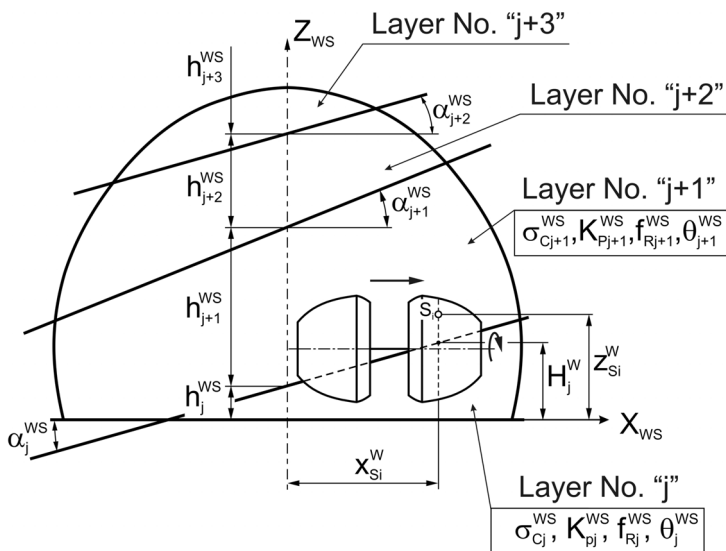

Fig. 5. Method of defining the geotechnical parameters of rock mass with layered structure with superimposed contour of roadheader cutting heads

In the current model, the arching movement of the cutting heads was replaced by a straight-line movement toward axis X (axis of rotation of the cutting heads), parallel to axis X_{WS} , at

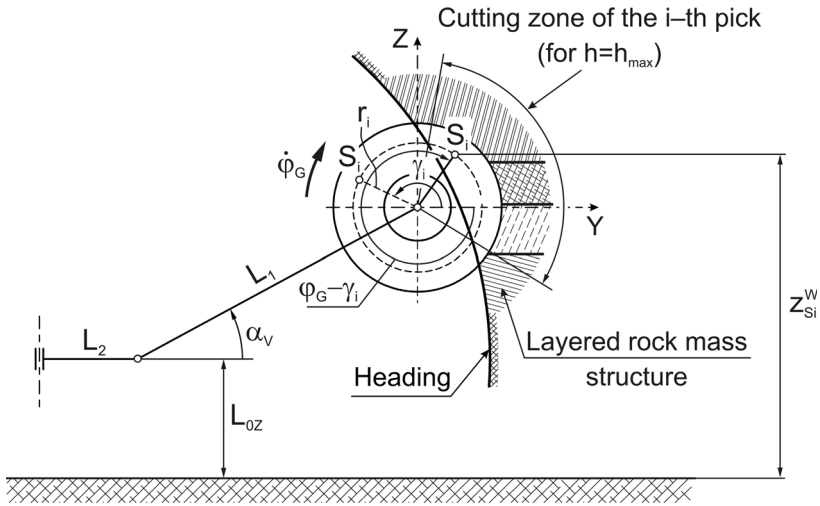

Fig. 6. Position of the tip vertex of the i -th pick (point S_i) with view to the plane perpendicular to the floor depending on the values of angle: of cutting head rotation ϕ_G and boom deflection in the plane perpendicular to the floor α_V

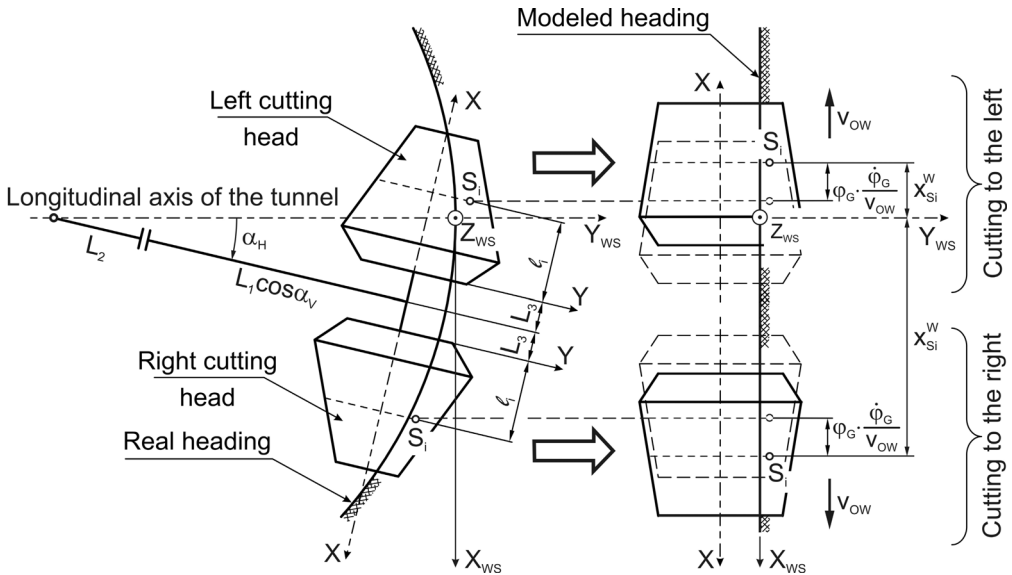

Fig. 7. Position of the tip vertex of the i -th pick (point S_i) with view to the plane parallel to the floor depending on the values of angle: of the rotation of the cutting head ϕ_G and deflection of the boom α_H and α_V

a velocity of v_{OW} along the flat surface of the heading (Fig. 7). In order to ensure adequacy of the results obtained in this way (pattern of the cut depth) with the reality, a transformation of the cutting head shape is performed. It consists of determining the r_i coordinates of the tips of the

individual picks at which the depths of the cuts performed by the picks of the cutting head in a straight-line movement will be equal to the cut depths made by the picks during the movement of the cutting head along an arc, along the heading surface of spherical shape (Sobota, 2015; Dolipski et al., 2017).

The load generated by the picks during the excavation process is the starting point for predicting the cutting head load and the energy consumed in carrying out this process. In order to determine this load it is necessary to find in which rock layer a given pick is located. The following equation is used to identify a rock layer for the i -th pick and further for ascribing the mechanical parameter values of the rock being cut by the pick in a given position:

$$z_{S_i}^W(\varphi_G, \alpha_H, \alpha_V) \geq H_{j-1}^W \cap z_{S_i}^W(\varphi_G, \alpha_H, \alpha_V) < H_j^W \quad \text{for } j = 2, 3, \dots, n_{WS} \quad (2)$$

whereas

$$H_j^W = \sum_{k=1}^j h_k^{WS} + x_{S_i}^W(\varphi_G, \alpha_H, \alpha_V) \cdot \operatorname{tg} \alpha_j^{WS} \quad (3)$$

Index “ i ” stands for the pick number for which the mechanical parameter values of the excavated rock are determined, whereas index “ j ” stands for the rock layer number with which i -th pick is in momentary contact (for the current value of the cutting head rotation angle φ_G).

When simulating a cutting head rotation around its own axis with the angular speed $\dot{\varphi}_G$, while it is simultaneously moving parallel to the floor with the speed v_{OW} , for each pick engaged in the excavation process, a rock layer is searched with which it is in contact at that moment. For the current rotation angle of the cutting head φ_G , the current value of the cutting head movement, and for the value of the angle of boom deflection α_V , a rock layer is identified for which the condition (2) is met. The values characterizing the properties of the particular rock layer found by this method are ascribed to the given (i -th) pick being considered:

$$\begin{bmatrix} \sigma_{C_i}(\varphi_G) \\ K_{P_i}(\varphi_G) \\ f_{R_i}(\varphi_G) \\ \theta_i(\varphi_G) \end{bmatrix} = \begin{bmatrix} \sigma_{C_j}^{WS} \\ K_{P_j}^{WS} \\ f_{R_j}^{WS} \\ \theta_j^{WS} \end{bmatrix} \quad (4)$$

Based on the values of the mechanical parameters of the rock cut, instantaneous values of the picks' load components can be determined for the current position of the vertexes of the picks which are active in the cutting process at that moment. Furthermore, values for the load components of the cutting head, its load-carrying structure, the boom deflection mechanism, and average values of the energy consumed by this process can be determined as well. Computer simulations may include cutting head movement, toward the right or left tunnel sidewall and across the surface of the heading within the variable range of the boom deflection angle α_H . As the heading surface will not be flat but spherical, variations in the values of the parameters of the cuts can be considered – the web z and the height h (in the case where simulations include cutting with the maximum height possible for the given size of the web $h = h_{\max}$). The web value z can be determined from the value representing the movement of the cutting heads toward the heading during sumping y_{\max} (measured in the longitudinal axis of the tunnel) for the current boom

deflection angle values on the planes parallel and perpendicular to the floor: $z = f(y_{\max}, \alpha_H, \alpha_V)$ (Fig. 3). In turn, the height of the cut depends on the current value of web and the angle of the boom deflection at a plane perpendicular to the floor: $h = f(z, \alpha_V)$. The web, together with the height of the cut, has an effect on the size of its cross section, which determines cutting efficiency (in association with the cutting heads movement speed v_{OW}) as well as the load on the cutting head (resulting, particularly, from the number of picks currently in contact with the rock).

3. Computer simulations

One object involved in this study was a transverse cutting head fitted with 54 conical picks. It was equipped with 45 picks arranged on the main part of the cutting head along three helixes with a large angle of rotation and an additional 12 helixes with a small angle of rotation along its trunk (Fig. 8). Other 9 picks were arranged on the gear side of the cutting head. The maximum diameter of the head, measured along the sleeve of the picks, was $D_{\max} = 800$ mm, and the minimum diameter was $D_{\min} = 300$ mm. The length of this cutting head (measured along its axis of rotation at the tip vertex of picks) was $L = 466$ mm, and the length of its trunk (taking part in cutting during the execution of the work movement) was $L_Z = 331$ mm (see Fig. 3).

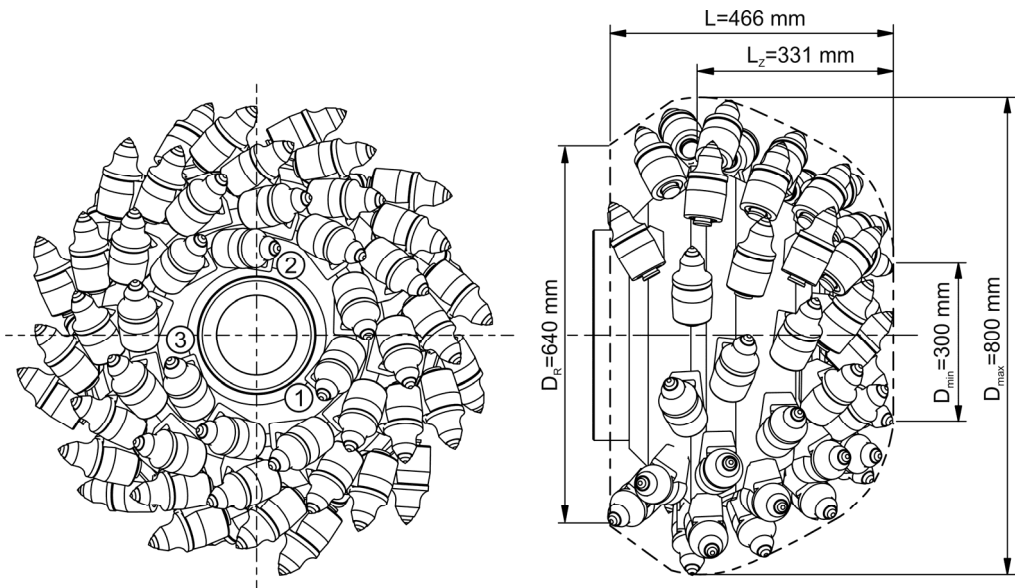

Fig. 8. Transverse cutting head equipped with 54 picks used in simulation tests

The simulation included cutting through a three layered rock mass with variable thicknesses and compressive strengths with a set lateral inclination (Table 1). Growing number of layers corresponds to the arrangement in the cross section of the heading from the floor to the roof. Computer simulations consisted of executing the excavation process of a rock mass with a layered structure with a shifting web, in variable locations of the heading, determined by the

boom deflection angular values α_H and α_V . For the purpose of computer simulations, original software written in Embarcadero RAD Studio was used. The method of computer simulation of the cutting process of the roadheader is described among others in (Dolipski et al., 2017). The algorithm has been extended with the ability to simulate the excavation of a rock mass with a layered structure, described in this article.

TABLE 1

Assumed values of parameters of rock layers in a cross section of the tunnel

Layer number	h^{WS}	α^{WS}	σ_C^{WS}	$K_P^{WS} = \sigma_C^{WS} / \sigma_T^{WS}$	f_R^{WS}	θ^{WS}
	[mm]	[deg]	[MPa]	—	—	[deg]
1	1485	-10	80.0	15.0	2.0	70.0
2	325	-10	25.0	20.0		
3	3000	-10	60.0	15.0		

Position of a pick on the side of the cutting head and its current position on the heading surface have an effect on the structure of the excavated rock mass in the cutting zones of the particular picks during cutting (see Fig. 6). In the example of the simulation where excavation to the right examined a layer with a web of $z = 0.15$ m and a maximum height of $h = h_{\max} = 0.65$ m, the cutting head picks (no. 7÷9) situated closest to the heading surface ($r = 220$ mm) were excavating rock with a uniaxial compressive strength (σ_C) of 25 MPa (Fig. 9a).

The portion of the excavated layer with a compressive strength of 60 MPa was growing as the distance was increasing between the vertexes of the picks and the axis of rotation of the cutting head. For example, in case of picks no. 13÷15 ($r = 270$ mm), for over 1/4 of the path in which the picks were in contact with the excavated solid, a rock was cut with a compressive strength of 60 MPa, and for the remaining distance – a layer for which $\sigma_C = 25$ MPa (Fig. 9b). The average compressive strength value of the rock cut in this case was 36 MPa. An additional layer with a compressive strength of 80 MPa (Fig. 9c) was situated in the cutting zone of the picks on their largest radii. The portion of particular rock layers excavated by the picks no. 37÷39 was 46% ($\sigma_C = 25$ MPa), 34% ($\sigma_C = 60$ MPa), and 20% ($\sigma_C = 80$ MPa); the average value of compressive strength of the excavated rock mass resulted in 48 MPa. The portion of particular rock layers excavated depends, first of all, on the values of the boom deflection angle on the planes parallel and perpendicular to the floor. While simulating the cutting of a layer parallel to the floor for a specific web, with the set angle value α_V , the structure of the rock mass being cut by specific head picks will change as the boom deflects toward one of the sidewalls of the tunnel. In the case analyzed here ($\alpha_H = 0^\circ$), where every pick is involved in the excavation of the heading surface, with set parameter values for the process simulated, the excavation of a rock layer with a compressive strength of 25 MPa had the largest share (59%) (Fig. 10). The portion of rock with the highest compressive strength ($\sigma_C = 80$ MPa) was the smallest position considered for the cutting head (10%).

When simulating the excavation parallel to the floor in scope of the boom deflection angle α_H from -36° to $+36^\circ$ (the boom deflected to the right) for the layered structure of rock mass discussed, a highly variable average compressive strength value of the rock mass was noticeable. The average compressive strength of the excavated solid changed between 41 and 71 MPa, therefore, by a range of 75% (Fig. 11, purple line). The minimum value of this parameter corresponded to a boom deflection angle value α_H of 0° . The maximum value, however, was noticed

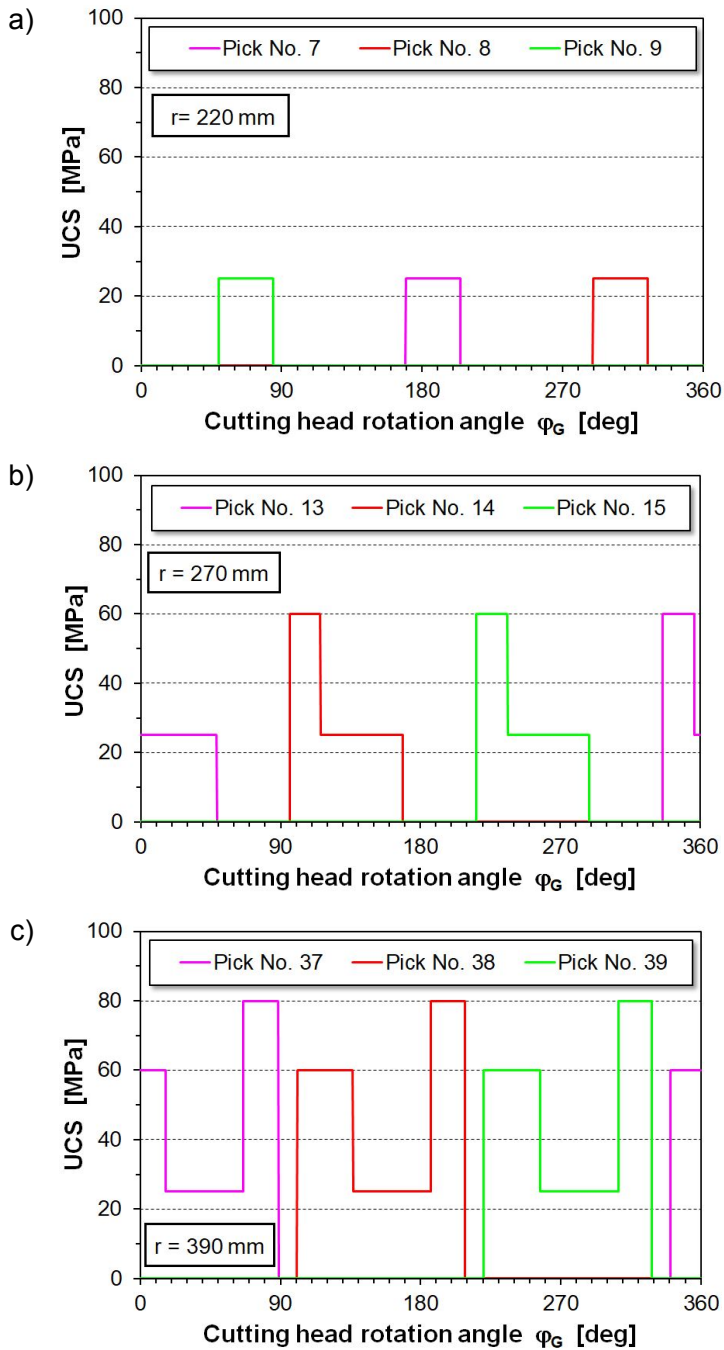

Fig. 9. Curve of variability of compressive strength of the rock cut by the selected picks obtained during computer simulation of cutting the rock mass with layered structure for $\alpha_H = 0^\circ$ and $\alpha_V = -2^\circ$ ($v_{OW} = 0.05 \text{ m/s}$; $\dot{\varphi}_G = 9.24 \text{ rad/s}$; $z = 0.15 \text{ m}$; $h = h_{\max} = 0.65 \text{ m}$)

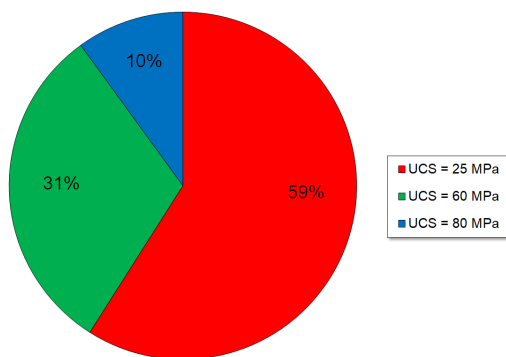

Fig. 10. Rate of cutting the rocks with specific compressive strength by the picks of the studied cutting head for $\alpha_H = 0^\circ$ and $\alpha_V = -2^\circ$ ($v_{OW} = 0.05$ m/s; $\dot{\varphi}_G = 9.24$ rad/s; $z = 0.15$ m; $h = h_{\max} = 0.65$ m)

by the maximum deflection of the boom to the left ($\alpha_H = -36^\circ$). The curve of the average value of compressive strength of a rock mass depends, apart from the value of uniaxial compression strength of particular rock layers, on their portion. The portion of three rock layers considered here, due to their assumed transverse inclination, varied as the cutting head moved to the right (red, green, and blue lines in Fig. 11). For example, for the maximum boom deflection to the right ($\alpha_H = +36^\circ$), the average compressive strength of the rock mass, for which an excavation process was simulated, was higher than the value obtained for $\alpha_H = 0^\circ$, although in this area the picks were not touching a layer with the highest assumed compressive strength (80 MPa). In case of extreme boom deflection to the left ($\alpha_H = -36^\circ$), almost only a layer with $\sigma_C = 80$ MPa was cut. For the values of the angle α_H smaller than -18° , the picks were not in contact with the layer with a compressive strength of 60 MPa.

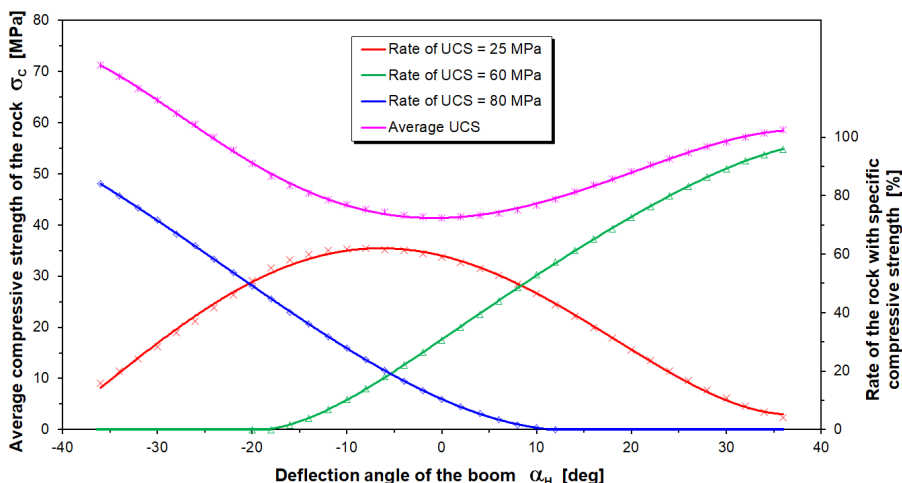

Fig. 11. Variations in the average value of compressive strength and proportion of particular rock layers according to the deflection angle of the boom with plane parallel to the floor to the right ($v_{OW} = 0.05$ m/s; $\dot{\varphi}_G = 9.24$ rad/s; $\alpha = -2^\circ$; $y_{\max} = 0.15$ m; $h = h_{\max} = 0.65$ m)

Layered rock mass structures, the deposition pattern of rock layers, and the differing values of their strength parameters (in association with other factors) influence the size and character of the load on the cutting picks. Variations in rock strength along the cutting path of the individual picks are visible in the curves of their load components. Figure 12 shows, for example, the curves of the cutting force (F_C) for the selected picks of a transverse cutting head. In case of picks 7÷9, the size and character of the load is a straightforward result from variations in the depth of the cuts performed and the shape of the force curve on the pick in the subsequent detachment cycles of rock grains (Fig. 12a). The form of the curve was identified on the basis of measurements carried out directly on the roadheader. The compressive strength of the rock for this group of picks was constant (Fig. 9a).

In case of picks 13÷15 and 37÷39 (Fig. 12b and c), the value of the load on the picks is significantly dependent on variations in the compressive strength of the excavated rock in the path where the picks contact the excavated solid. This load, however, is dependent not only on the mechanical properties of the excavated rock but also on the geometry of the cut performed by the pick (cutting force depends on the depth of the cut).

Figure 13 shows the influence of the web size on the movement of the cutting heads toward the heading (y_{\max}), and by the boom deflection angle value on the plane parallel to the floor (α_H) with the average energy consumed during excavation (P). The energy consumption is calculated as the product of the average torque on the shaft of the cutting head (calculated for each rotation of the cutting head) and its speed, taking into account the efficiency of the drive. The torque value results from the load (mainly cutting forces) of the picks being in contact with the cut rock at that moment. The cutting of a stratum with the maximum height for the particular web was simulated here ($h = h_{\max}$). The cutting head, by moving toward one of the sidewalls of the tunnel, went through rock layers with various compressive strengths. Consequently, the load on the cutting system fluctuated. A curve showing the variability of the average energy consumed in the cutting process represented as cutting power P (determined by the subsequent rotations of the cutting head) results from:

- the mechanical properties of the rock excavated by picks in relation to the particular cutting head position, characterized by an average compressive strength;
- the value of the cross section of the cut dependent on the current value of the web and height of the cut.

The first of the factors mentioned above results from the structure of the rock mass carried out by computer simulations and from the position of the cutting head on the heading surface, determined by the values of the boom deflection angles α_H and α_V . The size of the cross section of the cut results from the value of the head movement toward the heading y_{\max} , and from the values of boom deflection angles, that is, α_H and α_V .

The intensity of the above factors has a different influence. For instance, when analyzing cutting head movement from the left sidewall of the tunnel toward the right sidewall (the angle value α_H changes from -36° to $+36^\circ$, the black line), apparently excavation power in the initial phase decreased, despite the systematic increase in the web z and in the height of the cut h . This resulted from a decrease in the average value of compressive strength of the excavated rocks (Fig. 14, the black lines). The minimum of the function $P = f(\alpha_H)$ corresponds, approximately, to the minimum value of the average compressive strength of the rocks ($\alpha_H \approx -2^\circ$) – compare Fig. 13 with Fig. 14. A further increase in the value of the angle α_H was accompanied by an increased average compressive strength value of excavated rocks. This effect, accompanied at

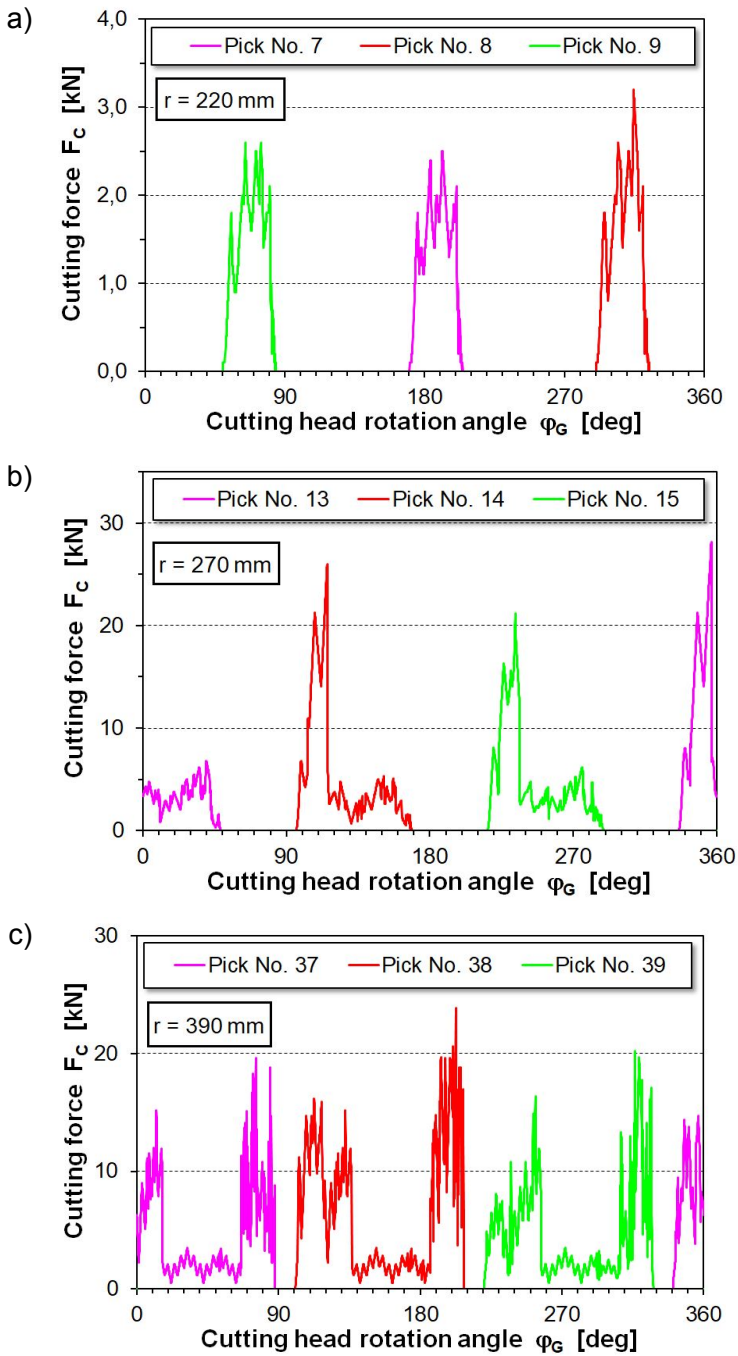

Fig. 12. Curve of variability of cutting force on the pick obtained during computer simulation of cutting the rock mass with layered structure for $\alpha_H = 0^\circ$ and $\alpha_V = -2^\circ$ ($v_{DW} = 0.05$ m/s; $\dot{\varphi}_G = 9.24$ rad/s; $z = 0.15$ m; $h = h_{\max} = 0.65$ m)

the same time by an decreased cross sectional field of the cut (due to the decreased web value and height of the cut) led to a increase in the energy consumed in the cutting process (Fig. 13). Therefore, rock workability had a dominant effect. After reaching the maximum, despite further growth in the average compressive strength of the rocks, the function $P = (\alpha_H)$ decreased again.

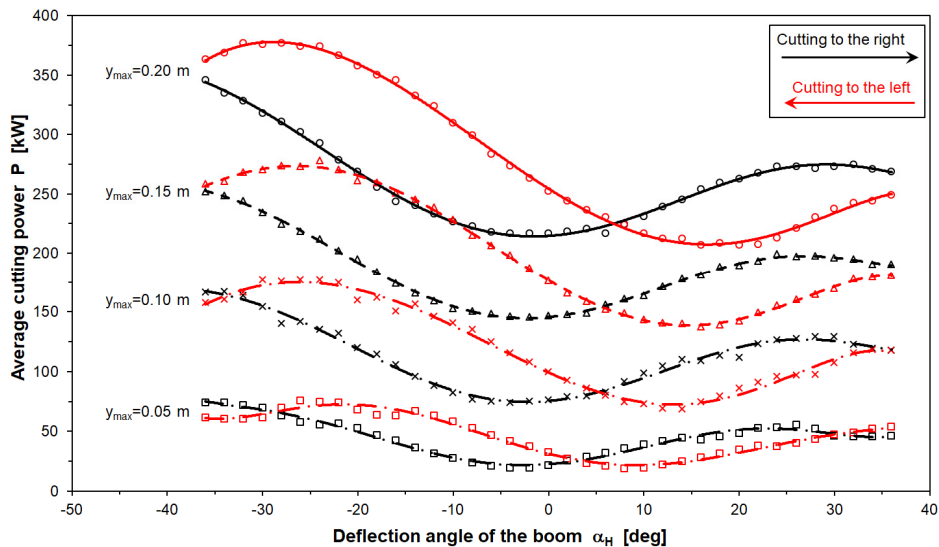

Fig. 13. The effect of cutting head movement direction on cutting power when cutting the rock mass with layered structure (for $v_{OW} = 0.05$ m/s; $\dot{\varphi}_G = 9.24$ rad/s; $h = h_{max} = 0.65$ m; $\alpha_V = -2^\circ$)

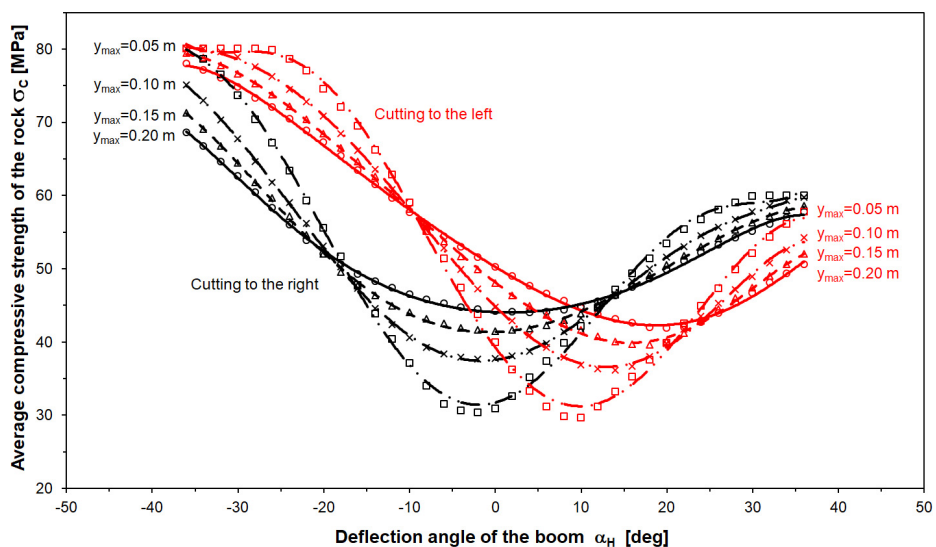

Fig. 14. The effect of cutting head movement direction on average compressive strength value of rock mass with layered structure (for $v_{OW} = 0.05$ m/s; $\dot{\varphi}_G = 9.24$ rad/s; $h = h_{max} = 0.65$ m; $\alpha_V = -2^\circ$)

This resulted from an decrease in the size of the field of the cross section of the cut, accompanied by the maximum boom deflection toward the sidewall of the tunnel.

The direction of excavation of a rock mass with a layered structure influences the load curve of the cutting heads and energy required to execute the process. In case of simulating the excavation of a layer parallel to the floor of the rock mass made of the three considered rock layers, the curves of dependency $P = f(\alpha_H)$ for boom deflection to the left (red lines) clearly differ from the curves of this function for boom deflection to the right (black lines). The examined characteristics obtained for excavation directed to the right and left intersect. The position of the intersection point for the four analyzed values of cutting head movement toward the heading y_{\max} corresponds to the value of the angle of boom deflection on the plane parallel to the floor α_H within a range of $+3^\circ$ to $+7^\circ$ (Fig. 13). The points are quite similar to the intersection points of the curves of the average compressive strength of the rock cut for cutting directed to the right or left (Fig. 14). For example, when $y_{\max} = 0.2$ m, for the value of the angle of boom deflection on the plane parallel to the floor of the range of -36° to $+7^\circ$, the average compressive strength of the rock for cutting directed to the left was higher by as much as 30% than that of the average σ_C values during the process of cutting directed to the right. But, for the boom deflection angle value (α_H) more than $+7^\circ$, the average compressive strength of the rock mass during cutting directed to the left was up to 20% smaller than that of the values corresponding to cutting directed to the right. Differences in shapes of the curves shown in Figures 13 and 14, illustrating the patterns of energy and average compressive strength of the mined rock as a function of angle α_H result from a different position of the right cutting head pick tips on the surface of the heading – when cutting to the right and of the left cutting head – when cutting to the left. The transverse cutting heads were away from the longitudinal axis of the boom by the distance L_3 (Fig. 3) as a result of the width of the gearbox in the drivetrain. Therefore, the right cutting head is moved away from the boom axis by this value to the right, whereas the left cutting head to the left. In addition, coordinate l_i of the right cutting head pick tips is measured along its axis of rotation to the right, whereas for the left cutting head – to the left (the left cutting head is a mirror image of the right cutting head) (Fig. 7). Consequently, for the given values of the deflection angle of the boom α_H and α_V , values of coordinates $x_{S_i}^W$ describing the position of the tips of individual picks on the surface of the heading in case of cutting to the right with the right cutting head are larger than that of the value for the left cutting head during cutting to the left (see equation (1)).

The curve and the energy consumed for excavation by the cutting head depends on the relationship between the stereometry parameters of the cutting heads, the values of the roadheader's operational parameters (the parameters of the cutting process), and the geotechnical parameters of the rock mass.

4. Summary

In this article, a mathematical model enabling computer simulation of the cutting process with roadheader's transverse cutting heads on the heading surface of a tunnel driven into a layered rock mass is presented. This model represents a significant development of the basic working process of roadheaders used in numerical studies of mathematical models to date, that is, mechanical rock excavation. This model allows the actual geological structure of excavated tunnels, and variations as the heading gradually advances, to be considered. It also enables the load of the roadheader cutting system to be associated with the position of the cutting heads on

the surface of the heading. This allows a computer simulation to be performed which accounts for the curve of the entire heading surface cutting cycle corresponding to the cut performed by a roadheader with a predefined web. The load on the cutting head during mining constitutes forcing vibrations in the cutting system, the boom, and its swinging mechanisms in the body of the roadheader. Determining its pattern by way of a computer simulation constitutes, therefore, a starting point for determining the dynamic state of the roadheader with the use of appropriate dynamic models.

The examples of computer simulations presented in this study clearly indicate that variations in the properties of the rock excavated as the cutting heads move along the heading surface, apart from other factors, may have a strong influence on the curve of the load of a roadheader cutting system, and thus on the performance and efficiency of the excavation process being conducted. The intensity of this influence depends on the configuration of rock layers in the cross section of the heading, the differentiation in the values of the parameters describing their mechanical properties (workability), and on the cutting technology applied.

The developed mathematical model, and its implementation in a computer program, represents a tool which allows the identification of the size and character of a load, the drive of cutting heads, and their load-carrying structure (boom), for the actual driving conditions of tunnels found in the underground mining of mineral resources and civil engineering. In addition, it allows numerical investigations to be performed for the optimization of a heading cutting technology in a layered rock mass for the selection of roadheader operational parameters at which this process is carried out. The developed mathematical model will be used in studies whose purpose is to develop an effective algorithm for the adjustment of cutting process parameters in a roadheader in the context of reducing dynamic loads and energy consumption in the conditions found in roadheader driven tunnels.

Acknowledgements

This work has been implemented under the research project titled “*Control of roadheader cutting heads movement for reduction of energy consumption of mining and dynamic loads*” co-financed by the Polish National Center for Research and Development under the Applied Research Projects (agreement no. PBS3/B2/15/2015).

References

- Avunduk E., Tumac D., Atala A.K., 2014. *Prediction of roadheader performance by artificial neural network*. Tunnelling and Underground Space Technology **44**, 3-9.
- Chen C.-S., Liu Y.-C., 2007. *Methodology for evaluation and classification of rock mass quality on tunnel engineering*. Tunnelling and Underground Space Technology **22**, 377-387.
- Dolipiski M., Cheluszka P., 1999. *Dynamic model of a roadheader's cutting system which incorporates transverse cutter heads*. Archives of Mining Sciences **44**, 1, 113-146.
- Dolipiski M., Cheluszka P., Sobota P., Reimorz E., 2017. *New computer simulation procedure of heading face mining process with transverse cutting heads for roadheader automation*. Archives of Mining Sciences **62**, 1, 83-104.
- Ebrahimabadi A., Goshtasbi K., Shahriar K., Cheraghi Seifabad M., 2011. *A model to predict the performance of road-headers based on the Rock Mass Brittleness Index*. The Journal of The Southern African Institute of Mining and Metallurgy **111** (5), 355-364.

- Famur, 2015. [http://famur.com.pl/oferta/kompleksy-chodnikowe/kombajny-chodnikowe /fr-250-954.html](http://famur.com.pl/oferta/kompleksy-chodnikowe/kombajny-chodnikowe/fr-250-954.html).
- Frenyo P., Lange W., 1993. *The design of cutter heads for optimum cutting powers*. Glückauf **129** (7), 524-531.
- Fries J., Hapla T., Neumann T., 2014. *Optimum parameters of mining machines for specific conditions*. In proceedings of SGEM 2014 GeoConference on Ecology, Economics, Education and Legislation, Volume III – Exploration and mining mineral processing. STEF92 Technology Ltd., Sofia, 435-442. DOI: 10.5593/SGEM2014/B13/S3.057.
- Galperin A.M., Zaytsev V.S., Norvatov Yu.A., 1993. *Hydrogeology and engineering geology*. A.A. Balkema Publishers, 377.
- Gunnarsson G.A., 2008. *Rock mass characterization and reinforcement strategies for tunnels in Iceland*. Master's thesis, Technical University of Denmark, 230.
- Heiniö M. (ed.), 1999. *Rock excavation handbook*. Sandvik Tamrock Corp., 364.
- Hjálmarsson E.H., 2011. *Tunnel Support*. Use of Lattice Girders in Sedimentary Rock. University of Iceland, 94.
- Jamie M.C., 2011. *Numerical modeling of rock cutting and its associated fragmentation process using the finite element method*. Doctoral thesis, University of Pittsburgh, pp. 260.
- Jonak J., Rogala-Rojek, J., 2012. *Advisory system supporting roadheader operator*. KOMAG, Prace Naukowe – Monografie, No 38, pp. 132.
- Knissel W., Wiese, H.-F., 1981. *Improving the extractive action of selective roadheaders*. Glückauf **117** (20), 1360-1366.
- Li X., Huang B., Li C., Jiang S., 2012. *Dynamics Analysis on Roadheader Cutting Head Based on LS-DYNA*. Journal of Convergence Information Technology **7** (23), 333-340.
- Peng S., Zhang J., 2007. *Engineering geology for underground rocks*. Springer-Verlag, 315.
- Rojek J., 2007. *Discrete element modeling of rock cutting*. Computer Methods in Material Science **7** (2), 224-230.
- Sanyhe, 2015. <http://sanyhe.com/company/zz/en-us/products/EBZ260HRoadheader.htm>.
- Sikora W. (ed.), 2000. *Determination of forces and energy consumption of excavation with conical picks*. Silesian University of Technology Publishing House, 331.
- Sobota P., 2015. *The impact of the roadheader boom settings and pics position on the cutting depth*. 34th International Conference "Technical diagnostics of machines and manufacturing equipment DIAGO 2015", 249-257.
- Sun Y., Li X.S., 2014. *Ineffective Rock Breaking and its Impacts on Pick Failures*. The 31st International Symposium on Automation and Robotics in Construction and Mining (ISARC 2014), Sydney, 754-760.
- Weber Mining, 2015. <http://www.weber-mining.com/page146-wzmacnianie-przodkow-chodnikowych-i-przekopow.html>.
- Wiese H.-F., 1982. *Basic research to optimize the cutting process of the transverse cutter head of roadheaders*. Doctoral thesis, TU Clausthal, 125.