

SLIDING MODE CONTROL FOR LONGITUDINAL AIRCRAFT DYNAMICS

Submitted: 20th July 2018; accepted: 18th September 2018

Olivera Iskrenovic-Momcilovic

DOI: 10.14313/JAMRIS_3-2018/18

Abstract:

The control of the longitudinal aircraft dynamics is challenging because the mathematical model of aircraft is highly nonlinear. This paper considers a sliding mode control design based on linearization of the aircraft, with the pitch angle and elevator deflection as the trim variables. The design further exploits the decomposition of the aircraft dynamics into its short-period and phugoid approximations. The discrete-time variable structure system synthesis is performed on the base of the elevator transfer function short-period approximation. This control system contains a sliding mode controller, an observer, based on nominal aircraft model without finite zero and two additional control channels for the aircraft and for the aircraft model. The realised system is stable and robust for parameter and external disturbances.

Keywords: aircraft dynamics, control, elevator, longitudinal, sliding mode

1. Introduction

Aircraft dynamics characterizes the motion of an aircraft in the atmosphere. The response of the aircraft to aerodynamic, propulsive and gravitational forces, and to control inputs from the pilot determine the attitude of the aircraft and its resulting flight path [1]. In the past literature the special attention is dedicated the aircraft dynamics stability. The concept of aircraft dynamic stability studies what is doing with the aircraft in one time period, when it took out the balanced position. The longitudinal aircraft motion is the aircraft response on the disturbances [2].

To date, flight control widely uses linear control techniques. One of the reasons is the existence of numerous tools for assessing the robustness of the linear feedback controller [3]. Another reason is that flight control techniques are developed primarily for commercial aircrafts that are designed and optimized for flying along very specific trajectories [4]. However, in recent years, PID controllers have been used to improve the dynamic characteristics of the aircraft flight [5–7]. PID controllers are widely used, partly because they are effective and partly because of their simple structure and robust performance in a wide range of operating conditions [8]. Often, the fuzzy logic controller is used alone or to optimize the design of the PID controller [9–12].

Sliding mode control (SMC) is a nonlinear approach which is inherently robust against matched uncertainty [13]. The application of SMC to flight control has been pursued by several others authors [13–19]. The most commonly designed non-linear controller, which is designed based on the linearization of the aircraft. The design exploits the short-period approximation of the linearized flight dynamics [14]. Today, a controller is created based on combination of the traditionally PD controller and a sliding mode controller [18, 19]. All that control systems are obtained for continual time domen, while there is little attempt at this realization in a discrete domain [20, 21].

2. Longitudinal Aircraft Dynamics

The aircraft is a dynamic system influenced by control and external disturbance. The control is realized by correcting the position and path of the aircraft. In this way allows the aircraft motion in the desired direction.

The transfer function of the aircraft can be obtained by using the equations of aircraft motion. The equations of aircraft motion for the aircraft can be derived by applying Newton's laws of motion, After that linearization, the equations of aircraft motion are obtained the following form [22]:

$$\begin{aligned}
 \Sigma F_x &= m(\ddot{U} + WQ) \\
 \Sigma F_y &= m(\ddot{V} + UR - WP) \\
 \Sigma F_z &= m(\ddot{W} - UQ) \\
 \Sigma M_x &= \tilde{P} I_x - \tilde{R} J_{xz} \\
 \Sigma M_y &= \tilde{Q} I_y \\
 \Sigma M_z &= \tilde{R} I_z - \tilde{P} J_{xz}
 \end{aligned} \tag{1}$$

where:

m – mass of aircraft,
 F_x – external forces in x direction,
 F_y – external forces in y direction,
 F_z – external forces in z direction,
 M_x – rolling moment,
 M_y – pitching moment,
 M_z – yawing moment,
 u – linear velocity v_T in x direction,
 v – linear velocity v_T in y direction,

w – linear velocity v_T in z direction,
 P – angular velocity ω in x direction,
 Q – angular velocity ω in y direction,
 R – angular velocity ω in z direction,
 I_x – moment of inertia in x direction,
 I_y – moment of inertia in y direction,
 I_z – moments of inertia in z direction,
 J_{xz} – product of I_x and I_z .

The aircraft motion (1) can be divided into two parts:

- aircraft longitudinal motion,
- aircraft lateral motion.

The aircraft should have a straight and balanced flight, which can be distributed by deflection of the elevator. This deflection changes M_y , causes rotation about y axis and changes F_x and F_z , but does not change M_x , M_z , and F_y . Therefore, the following relations apply $P = R = V = 0$ so ΣF_y , ΣM_x and ΣM_z equations can be eliminated. This leaves equations of aircraft longitudinal motion:

$$\begin{aligned}
 \Sigma F_x &= m(\ddot{U} + WQ), \\
 \Sigma F_z &= m(\ddot{W} - UQ), \\
 \Sigma M_y &= \ddot{Q} I_y
 \end{aligned} \quad (2)$$

Let the axes x_E, y_E and z_E are earth reference axes. The axes x_0, y_0 and z_0 are equilibrium aircraft axes and the axes x, y and z are the distributed aircraft axes. Let us:

- γ is the flight path angle, that is the angle, measured in the vertical plane, between the horizontal and the velocity vector of the aircraft,
- α is the angle of attack, that is the angle between the velocity vector and the wing chord
- Θ is the angle between axes x_E and x in the vertical plane,
- θ is the pitch angle, that is the angle between the equilibrium vector U_0 and the vector of velocity change u .

The axis x is could be aligned with the longitudinal axis of the aircraft. Making these substitutions the equations (2) become:

$$\begin{aligned}
 \Sigma F_x &= m(\dot{u} + wq), \\
 \Sigma F_z &= m(\dot{w} - U_0 q - uq), \\
 \Sigma M_y &= \dot{q} I_y,
 \end{aligned} \quad (3)$$

Let's assume that there are negligible perturbations of disturbances about the equilibrium state and negligible angles between the equilibrium and disturbed axes. These assumptions allow for linearization of aircraft longitudinal motion. Thus the equations (3) can be written as follows:

$$\begin{aligned}
 \Sigma F_x &= m\dot{u}, \\
 \Sigma F_z &= m(\dot{w} - U_0 \dot{\theta}), \\
 \Sigma M_y &= \ddot{\theta} I_y,
 \end{aligned} \quad (4)$$

If the aerodynamic constants of the aircraft C_{**} will be defined and be applied Laplace transform, the longitudinal equations of motion for the aircraft (4) can be obtained as:

$$\begin{aligned}
 \left(\frac{mU}{Sq} s - C_{xu} \right) u_n(s) - C_{z\alpha} \alpha_n(s) - C_w \cos \theta \theta(s) &= 0 \\
 -c_{zu} u_n(s) + \left[\left(\frac{mU}{q} - \frac{c}{2U} C_{z\alpha} \right) s - C_{z\beta} \right] \alpha_n(s) + \\
 \left[\left(\frac{mU}{Sq} - \frac{c}{2U} C_{z\alpha} \right) s - C_w \sin \theta \right] \theta(s) &= 0 \quad (5)
 \end{aligned}$$

$$\left(\frac{c}{2U} C_{m\alpha} s - C_{m\epsilon} \right) \alpha_n(s) + \left(\frac{I_y}{Sq} s^2 - \frac{c}{2U} C_{mq} s \right) \theta(s) = 0$$

The characteristic equation of the system (5) is:

$$(s^2 + 2\varepsilon_p \omega_{np} s + \omega_{np}^2)(s^2 + 2\varepsilon_s \omega_{ns} s + \omega_{ns}^2) = 0$$

where:

ω_{np}, ω_{ns} – natural frequencies,

$\varepsilon_p, \varepsilon_s$ – damping factors.

There are two types of oscillations:

- the short-period oscillations with (Fig. 1),
- the phugoid oscillations (Fig. 2).

The periods and the damping of these oscillations varies from aircraft to aircraft because they depend on flight conditions' oscillations.

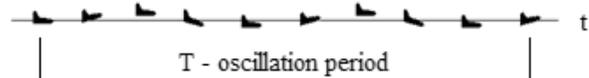

Fig. 1. Short-period oscillations

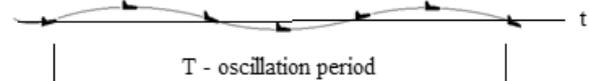

Fig. 2. Long-period oscillations

The short-period oscillations cause a change in the α_n and θ with negligible change u_n and the phugoid oscillations cause a change in the θ and u_n with negligible change α_n . Phugoid oscillations represent an change of potential and kinetic energy.

In the beginning, the aircraft has a sinusoidal flight path in vertical plane. When an aircraft flying from the highest point of the path down, it increases the speed to the lowest point, and when it flies up to the highest point of the path, it reduces the speed. This is repeated until an even flight is established. The phugoid oscillations period is very large so the flight of the aircraft can be successfully carried out.

3. Aircraft Elevator Control

Longitudinal aircraft dynamics is controlled by elevators. They are flight control surfaces, usually at the rear of an aircraft, which control the aircraft's pitch, and therefore the angle of attack and the lift of the wing. The aircraft is considered to be in straight and level non-accelerated flight and then to be distributed by deflection of the elevator. By aircraft longitudinal motion (Fig. 3) the control magnitudes are: α – angle of attack, θ – pitch angle, u – variation of flight velocity

along the longitudinal axis x , and control input is: δ_e – elevator deflection.

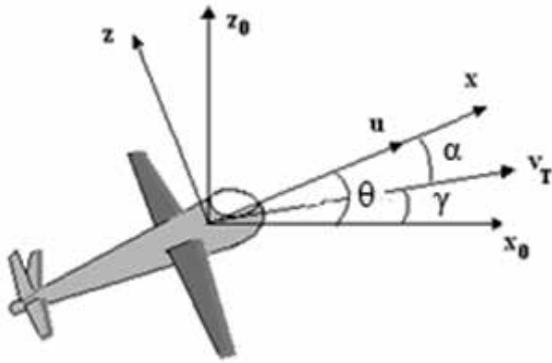

Fig. 3. Longitudinal aircraft motion

Based on the aircraft aerodynamic constants values [22] is obtained the transfer function of the aircraft elevator:

$$\frac{\theta(s)}{\delta_e(s)} = \frac{-1.31(s + 0.16)(s + 0.3)}{(s^2 + 0.0466s + 0.0053)(s^2 + 0.806s + 1.311)} \quad (6)$$

The transfer function (6) can be approximated with the function:

$$\frac{\theta(s)}{\delta_e(s)} = \frac{-1.39(s + 0.306)}{(s^2 + 0.805s + 1.325)} \quad (7)$$

The short-period approximation (7) is particularly good in the vicinity of the natural frequency of short-term oscillations. All this allows us to use this function for the realization of aircraft elevator control.

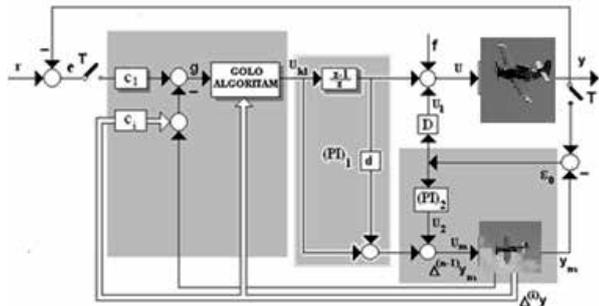

Fig. 4. Aircraft elevator control

In Fig. 4. given a block diagram of the system for aircraft elevator control, which will be analyzed. The discrete-time variable structure system synthesis is performed on the base of the elevator transfer function short-period approximation (7), which has stable finite zero. This control system contains a sliding mode controller; an observer, based on nominal aircraft model without finite zero and two additional control channels for the aircraft and for the aircraft model.

In the aircraft control channel is introduced the integrated (I) action, and in the observer control channel proportional-integral $(PI)_1$ action. The parameters of the action in the observer control channel are chosen so that the total nominal transfer function of the

control signal to the output of the aircraft and the observer, without feedback the observation error, identical. In addition, in order to achieve better robustness to external disturbance in the observation error channel is introduced also linear $(PI)_2$ action.

More specifically, $(PI)_2$ action is introduced for increasing the ability of the observer to observed changes slowly disturbances $f(t)$. Except that, in addition to acting on the observer is carried out and further action on the input of the plant from the observation error channel. Without this action, the system is very slow to release external disturbances or may occur oscillation. In fact, the introduction $(PI)_2$ action in the observer control channel and I action in the plant control channel was increased the equivalent plant order in $n + 1$.

Sliding mode is organized in order subspace and the design process VSC introduced PI action is not essential [15]. In the considered system, due to the presence and activities in front of the plant is irrelevant the discontinuity of the control signal. Breaking control is integral and it becomes constant at the input of the plant, and all the problems associated with stable zero and breaking control therefore are not relevant.

It is assumed that the aircraft parameters are non-stationary, but with the speed of change is much smaller than the dynamics of the process that takes place in a control system. In order to validate the proposed combination of variable structure control law with flexible working regimes of linear control law and PI-type discrete-time VSC is designed and simulated on the PC to control aircraft as a third order plant with stable finite stable zero (6):

$$W_{air}(s) = \frac{k(s + d)}{s^3 + a_3 s^2 + a_2 s} \quad (8)$$

$$0.605 \leq a_3 \leq 1.005, 1.125 \leq a_2 \leq 1.525$$

$$1.19 \leq k \leq 1.590, 1.06 \leq d \leq 0.506$$

$$f(t) = 0.1 h(t - 15) \sin \pi t$$

At the input of the plant is introduced I action, so that the extended transfer function of the plant becomes:

$$W_{air}^P(s) = \frac{s + d}{s} \frac{k}{s^3 + a_3 s^2 + a_2 s} = \left(1 + \frac{d}{s}\right) \frac{k}{s^3 + a_3 s^2 + a_2 s}$$

The extended aircraft can be seen as a plant without stable finite zero, which is added to PI action with constant parameters. In addition the expanded aircraft is introduced as the reduced transfer function of aircraft with nominal values of the parameters without finite zero. This reduced aircraft describes the transfer function:

$$W_{air}^R(s) = \frac{k_m}{s^3 + a_3 s^2 + a_2 s} k_m = 1.39 \quad (9)$$

Continuous model of reduced aircraft (9) in the canonical controllable form:

$$\dot{\mathbf{x}}(t) = \mathbf{A}\mathbf{x}(t) + \mathbf{b}u(t) \quad (10)$$

where:

$$\mathbf{A} = \begin{bmatrix} 0 & 1 & 0 \\ 0 & 0 & 1 \\ 0 & -1.325 & -0.805 \end{bmatrix} \quad \mathbf{b} = \begin{bmatrix} 0 \\ 0 \\ 1.39 \end{bmatrix}$$

This reduced model of the plant can be realized by computer (discretely). According to the theorem on selection, was chosen sampling time $T = 0.4$ ms. By δ applying the transformation for the selected sampling time, a discrete-time model of the system (10) becomes [23]:

$$\delta\mathbf{x}(k) = \mathbf{A}_\delta\mathbf{x}(k) + \mathbf{b}_\delta u(k) \quad (11)$$

where:

$$\mathbf{A}_\delta = \begin{bmatrix} 0 & 1 & 0.002 \\ 0 & 0 & 0.9996 \\ 0 & -1.3249 & -0.7999 \end{bmatrix} \quad \mathbf{b}_\delta = \begin{bmatrix} 0 \\ 0.002 \\ 1.3899 \end{bmatrix}$$

Let the sliding hyperplane defined by [24]:

$$g(k) = \mathbf{c}_\delta\mathbf{x}(k) \quad (12)$$

where:

$$\delta_i = \frac{e^{-\alpha_i T} - 1}{T} \alpha_i > 0 \quad i = 1, 2, \dots$$

$$\mathbf{c}_\delta = [\mathbf{c}_1 \quad \mathbf{c}_2 \quad \mathbf{1}]\mathbf{P}^{-1}$$

$$\mathbf{P} = [\mathbf{b}_\delta \quad \mathbf{A}_\delta^1 \mathbf{b}_\delta \quad \mathbf{A}_\delta^2 \mathbf{b}_\delta] \begin{bmatrix} \bar{a}_1 & \bar{a}_2 & 1 \\ \bar{a}_2 & 1 & 0 \\ 1 & 0 & 0 \end{bmatrix}$$

\bar{a}_1, \bar{a}_2 - coefficients of the characteristic polynomial $\det(z\mathbf{I} - \mathbf{A}_\delta) = z^3 + \bar{a}_2 z^2 + \bar{a}_1 z + \bar{a}_0$.

If $\alpha_1 = 1$ and $\alpha_2 = 1$ are chosen, the elements of the vector \mathbf{c}_δ (12) become:

$$\mathbf{c}_\delta = [-0.20008 \quad -0.40008 \quad -0.09996]$$

For the discrete-time model of reduced aircraft (11) can be synthesized control in the form:

$$u_{kl}(k) = -\mathbf{c}_\delta \mathbf{A}_\delta \mathbf{x}(k) - \min\left(\frac{|g(k)|}{T}, \alpha + \beta |g(k)|\right) \text{sgn}(g(k)) \quad (13)$$

where: α, β - real numbers such that $0 \leq \beta T < 1$ and $\alpha < 0$. Let $\alpha < 50$ and $\beta < 50$. Control (15) is:

$$u(k) = -0.208 x_2(k) - 0.20048 x_3(k) + \min(25000 |g(k)|, 50 + 20 |g(k)|)$$

$$g(k) = -20008 e(k) + 0.40008 x_2 + 0.09996 x_1(k)$$

4. An Illustrative Example

To ensure the robustness of the system to parameter changes of the plant and the external disturbance, is introduced by the feedback signal observation errors between the outputs of the plant and the model, as shown in Fig. 5. $(PI)_2$ and D activities were chosen in the following form:

$$W_{PI2}(z) = 200 \frac{2z-1}{z} \quad W_D(z) = 5 \frac{z-1}{z}$$

For the selected sampling time $T = 0.4$ ms, the transfer function $W_{air}(z)$ (8) and $W_{air}^R(z)$ (9) are:

$$W_{air}(z) = \frac{1.6 \cdot 10^{-6} (z-1)}{z^3 - 2.9992 z^2 + 2.9984 z - 0.9992}$$

$$W_{air}^R(z) = \frac{6.4 \cdot 10^{-11}}{z^3 - 2.9992 z^2 + 2.9984 z - 0.9992}$$

The system would be stable, it is necessary and sufficient that the characteristic equation of the system:

$$P(z) = 1 + W_{air}(z)W_D(z) - W_{air}^R(z)W_{PI2}(z) \quad (14)$$

has all its roots inside the unit circle $|z| = 1$ in the z - plane. Checking the root of the characteristic equation (14) can be done by applying some of the criteria of stability, for example by applying Jury stability test. The characteristic equation (14) can be written in the form:

$$P(z) = p_n z^n + p_{n-1} z^{n-1} + \dots + p_1 z + p_0 \quad (15)$$

Now it gets Jury's scheme coefficients in the form [25]:

$$q_i = \begin{vmatrix} p_0 & p_{n-1} \\ p_n & p_i \end{vmatrix}, i = 0, \dots, n-1$$

$$r_j = \begin{vmatrix} q_0 & q_{n-i-j} \\ q_{n-1} & q_j \end{vmatrix}, j = 0, \dots, n-2 \quad (16)$$

$$s_k = \begin{vmatrix} r_0 & r_{n-2-k} \\ r_{n-2} & r_k \end{vmatrix}, k = 0, \dots, n-3$$

$$t_0 = \begin{vmatrix} u_0 & u_3 \\ u_3 & u_0 \end{vmatrix}, t_1 = \begin{vmatrix} u_0 & u_2 \\ u_3 & u_1 \end{vmatrix}, t_2 = \begin{vmatrix} u_0 & u_1 \\ u_3 & u_2 \end{vmatrix}$$

The necessary and sufficient conditions that equation (15) has all roots modulo less than one and that the system is stable are:

$$P(1) > 0, (-1)^n P(-1) > 0$$

$$|p_0| < |p_1|, |q_0| > |q_{n-1}| \quad (17)$$

$$|r_0| > |r_{n-2}|, |t_0| > |t_2|$$

The characteristic equation errors of this system (15) is

$$z^4 - 2.9992z^3 + 2.998408z^2 - 0.999216256z + 0.00000128 = 0 \quad (18)$$

Based on the relation (16) is obtained Jury's scheme coefficients and conditions (17) are

$$0.007192 > 0 \quad 7.996824 > 0$$

$$|0.000000128| < 1 \quad (19)$$

Since all the conditions (19) are met and the characteristic equation (18) has all roots modulo less than one, was the stability of the circuit of observation error.

Simulation results are presented in the form of a diagram step response of the aircraft (Fig. 6 and Fig. 7), control (Fig. 8) and switching functions (Fig. 9). Computer simulation shows that the system is robust when changing the values of the parameters of the aircraft in the given boundaries (Fig. 7). It also has good properties of eliminating external disturbances (Fig. 6).

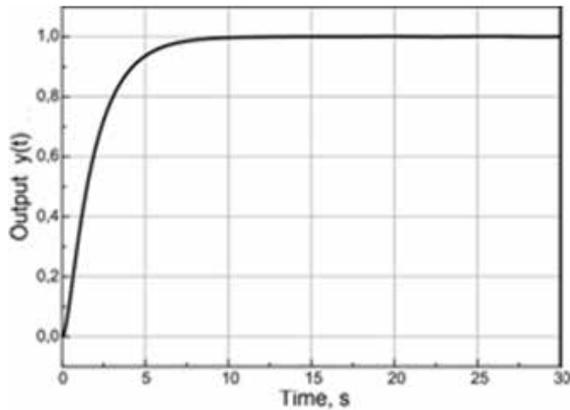

Fig. 5. Step response of nominal aircraft with load disturbance

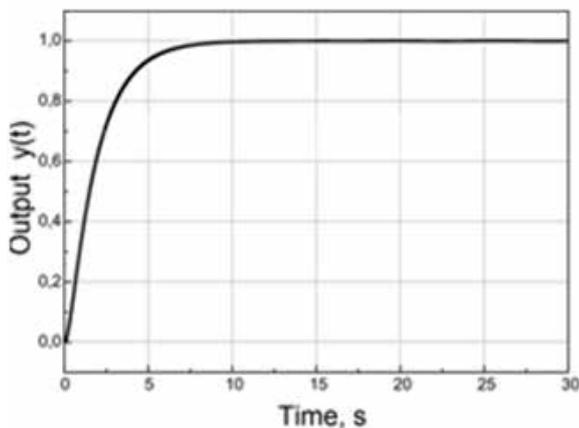

Fig. 6. Step response of aircraft for different values of parameters

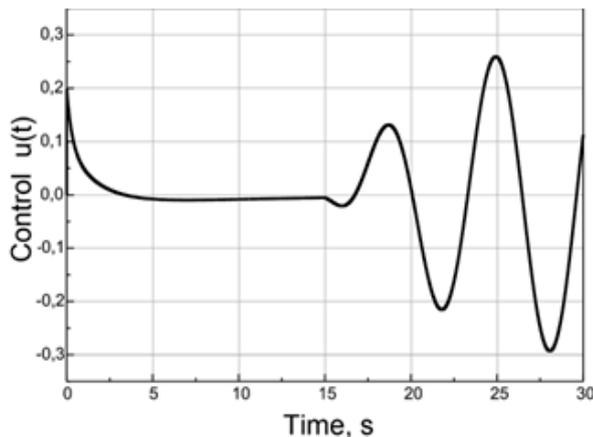

Fig. 7. Control of the nominal aircraft with load disturbance

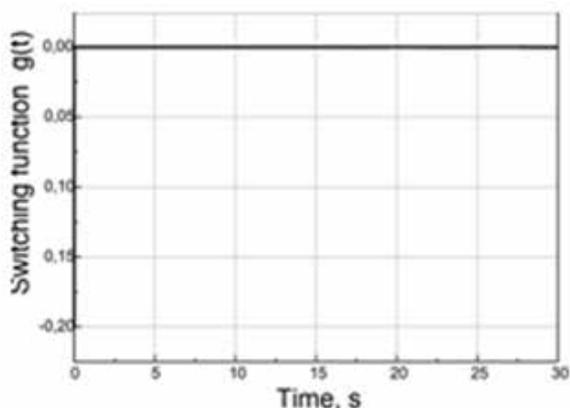

Fig. 8. Switching function of the nominal aircraft with load disturbance

5. Conclusions

It presented a new sliding mode control design for longitudinal aircraft dynamics. The design exploits the short-period approximation of the linearized aircraft dynamics. The control has a very simple structure: a sliding mode controller, an observer, based on nominal aircraft model without finite zero and two additional control channels for the aircraft and for the aircraft model. The robustness of the method to modeling uncertainty and disturbances, was demonstrated through extensive simulation, and the simulation results showed that the method outperforms, without any scheduling requirement, the transient and steady-state performance of a conventional gain-scheduled model-following controller. The realised system is stable and robust for parameter and external disturbances.

AUTHOR

Olivera Iskrenovic-Momcilovic – University of Novi Sad, Faculty of Education, Sombor, Serbia,
E-mail: oljkaisk@yahoo.com

REFERENCES

- [1] D.A. Caughe, "Introduction to aircraft stability and control course notes for M&AE 507", Sibley School of Mechanical & Aerospace Engineering Cornell University Ithaca, New York, USA. 2011.
- [2] P. Kvasnic, "Visualization of aircraft longitudinal-axis motion", *Computing and Informatics*, vol. 33, 2014, 1168–1190.
- [3] C. Roos, C. Doll, J.M. Biannic, "Flight control laws: recent advances in the evaluation of their robustness properties", *Journal of Aerospace Lab*, vol. 4, 2012, 1–9.
- [4] D. Pucci, "Analysis and Control of Aircraft Longitudinal Dynamics with Large Flight Envelopes", *Journal of Latex class file*, vol. 14, no. 8, 2015, 1–16.
- [5] S.N. Deepa, G. Sudha, "Longitudinal control of aircraft dynamics based on optimization of PID parameters", *Thermophysics and Aeromechanics*, vol. 23, no. 2, 2016, 185–194. DOI: 10.1134/S0869864316020049.
- [6] G. Sudha, S.N. Deepa, "Optimization for PID control parameters on pitch control of aircraft dynamics based on tuning methods", *Applied Mathematics and Information Sciences*, vol. 10, no. 1, 2016, 343–350. DOI: 10.18576/amis/100136.
- [7] N. Ives, R. Pacheco, D. Castro, R. Resende, P. Américo, A. Magalhães, "Stability control of an autonomous quadcopter through PID control law", *International Journal of Engineering Research and Application*, vol. 5, no. 5, 2017, 7–10.
- [8] M. Salem, M. Ali, S. Ashtiani, "Robust PID controller design for a modern type aircraft including handling quality evaluation", *American Journal of Aerospace Engineering*, vol. 1, no. 1, 2014, 1–7. DOI: 10.11648/j.ajae.20140101.11.

- [9] R. Zaeri, A. Ghanbarzadeh, B. Attaran, Z. Zaeri, "Fuzzy logic controller based pitch control of aircraft tuned with Bees algorithm". In: *Proceedings of the 2nd International Conference on Control Instrumentation and Automation (ICCIA)*, Shiraz University, Iran, 2011. DOI: 10.1109/ICCIAutom.2011.6356745.
- [10] V.G. Nair, M.V. Dileep, K.R. Prahalad, "Design of fuzzy logic controller for lateral dynamics control of aircraft by considering the cross-coupling effect of yaw and roll on each other", *International Journal of Computer Applications*, vol. 47, no. 13, 2012, 43–48. DOI: 10.5120/7252-0368.
- [11] K.D.S. Raj, G. Tattikota, "Design of fuzzy logic controller for auto landing applications", *International Journal of Scientific and Research Publications*, vol. 3, no. 5, 2013, 1–9.
- [12] S. Udayakumar, R. Kalpana, "A supporting fuzzy logic controller based on UAV navigation", *International Journal of Multidisciplinary Research and Modern Education*, vol. 1, no. 2, 2015, 208–210.
- [13] J. Liu, X. Wang, *Advanced sliding mode control for mechanical systems design – Analysis and MATLAB simulation*, Springer, Berlin, 2011. DOI: 10.1007/978-3-642-20907-9.
- [14] S. Seshagiri, E. Promtun, "Sliding Mode Control of F-16 Longitudinal Dynamics". In: *Proceedings of the American Control Conference*, Washington, USA, 2008.
- [15] H. Alwi, C. Edwards, "Fault tolerant longitudinal aircraft control using non-linear integral sliding mode", *IET Control Theory & Applications*, vol. 8, no. 17, 2014, 1803–1814. DOI: 10.1049/iet-cta.2013.1029.
- [16] L. Melkou, A. Rezoug, M. Hamerlain, "PID-terminal sliding mode control of aircraft UAV", *Proceedings of the UKSim-AMSS 8th European Modelling Symposium*. Pisa, Italy, 2014. DOI: 10.1109/EMS.2014.97.
- [17] N.B. Ammar, S. Bouallegue, J. Haggege, "Modeling and sliding mode control of a quadrotor unmanned aerial vehicle". In: *Proceedings of the 3rd international conference on automation, Control, Engineering and Computer science (ACECS'16)*, Hammamet, Tunisia, 2016.
- [18] M.T. Hamayun, C. Edwards, H. Alwi, A. Bajodah, "A fault tolerant direct control allocation scheme with integral sliding mode", *International Journal of Applied Mathematical and Computer Science*, vol. 25, no. 1, 2015, 93–102. DOI: 10.1515/amcs-2015-0007.
- [19] C. Aguilar-Ibañez, "Stabilization of the PVTOL aircraft based on a sliding mode and a saturation function", *International Journal of Robust and Nonlinear Control*, vol. 27, no. 5, 2017, 843–859.
- [20] S. Lona, A. Kumar, "Discrete sliding mode control for the lateral dynamics of a UAV with minimum control surfaces", *International Journal of Industrial Electronics and Electrical Engineering*, vol. 4, no. 1, 2016, 46–50.
- [21] S. Govindaswamy, T. Floquet, S.K. Spurgeon, "Discrete time output feedback sliding mode tracking control for systems with uncertainties", *International journal of Robust and Nonlinear Control*, vol. 4, no. 15, 2014, 2098–2211.
- [22] H.J. Blakelock, *Automatic control of aircraft and missiles*. John Wiley & Sons, New York, USA, 1985.
- [23] G. Golo, C. Milosavljevic, "Robust discrete-time chattering-free sliding mode control", *Systems and Control Letters*, vol. 4, 2000, 19–28.
- [24] C. Milosavljevic, "Variable structure systems of quasi-relay type with proportional-integral action", *Facta universitatis: Mechanics, Automatic Control and Robotics*, vol. 2, no. 7, 1997, 301–314.
- [25] R.M. Stojic, *Digitalni sistemi upravljanja* (Digital control systems), Publ.: Nauka, Belgrade, 1990 (in Serbian).