



Cent. Eur. J. Energ. Mater. 2023, 20(4): 455-477; DOI 10.22211/cejem/176915

Article is available in PDF-format, in colour, at:

<https://ipo.lukasiewicz.gov.pl/wydawnictwa/cejem-woluminy/vol-20-nr-4/>



Article is available under the Creative Commons Attribution-NonCommercial-NoDerivs 3.0 license CC BY-NC-ND 3.0.

Research paper

Experimental Study on the Diverse Output Performance of a Firearm Firing-Ignition System

Bo Li^{1,*}, Yanzhong Wei², Changfan Xin³, Zhifang Wei³, Yukun Shi³

¹) *School of Instrument and Electronics, North University of China, Taiyuan, Shanxi, China*

²) *Shandong Special Industry Group Co. Ltd., China*

³) *School of Mechanical and Electrical Engineering, North University of China, Taiyuan, Shanxi, China*

* *E-mail: libo@nuc.edu.cn*

Abstract: The firearm firing-ignition system performs firing and ignites a bullet propellant to produce diverse outputs. The objectives of this study were to extract various performance parameters characterizing the firearm firing-ignition system and to study the system output performance. The firing pins, primers, and cartridge cases were used as test objects, and a method for testing the diverse output performance of the firearm firing-ignition system is proposed based on the real assembly relationship of firearms. The pressure output patterns and flame characteristics were analyzed under different operating conditions and ambient temperatures. With increasing firing energy, the pressure start time and peak arrival time of the firearm firing-ignition system output decreased, whereas the length of the flame output generally increased. The flame duration was positively correlated with the firing energy. The development of the shape and temperature of the flame output could be categorized into four stages, where the maximum flame length of 60-70 mm occurred during the third stage and the highest temperature of 1218 °C was reached during the second stage. This study resolves the problem that the firearm firing-ignition system has a variety of outputs but only a single characterization parameter (the primer sensitivity) and engineering practice fails to quantitatively evaluate the system output performance.

Keywords: firearm, firing and ignition, versatile outputs, pressure resonance, flame shape and temperature

1 Introduction

Firearms are light weapons that fire ammunition to kill live targets and lightly armored targets. The components of a firearm that perform firing and ignite a bullet propellant are collectively referred to as the firearm firing-ignition system [1]. As the firearm firing-ignition performance of firearms directly affects the firing task, it is necessary to experimentally investigate the output performance of the firearm firing-ignition system.

A firearm firing-ignition system has various outputs (sound, light, and flame) and is therefore characterized by multiple physical parameters, including the intensity of the explosion sound, gas pressure, flame shape, and flame temperature. The drop-hammer sensitivity test is the main method used to test firearm firing-ignition performance in engineering practice. The test generally consists of using a mechanical drop-hammer machine [2] to measure the impact sensitivity of the firearm firing-ignition system, and an operator determines whether the primer has been fired based on a single dimension, the explosion sound. Thus, the test results are subjective and do not comprehensively and quantitatively measure the output performance of the firearm firing-ignition system. The firearm firing-ignition process is carried out in a small, enclosed space, where the firing time is on the order of hundreds of microseconds and the ignition time is on the order of milliseconds. Thus, it is difficult to measure and extract parameters for performance characterization, and it is necessary to develop experimental methods to quantitatively measure the various parameters that characterize the firearm firing-ignition system.

The closed bomb test is frequently used to experimentally determine the pressure-time ($p-t$) curve after primer firing to characterize the output performance of the primer [3-6]. Wang *et al.* [7] designed a cartridge to test the performance of a press-loaded small primer with fixed ammunition using the closed bomb test. The $p-t$ curve for the fired primer was used to determine the characteristic parameters, including the peak pressure, peak pressure arrival time, and pressure impulse, as measures of the primer ignition performance. Liu *et al.* [8] designed a set of triggers for a closed bomb to achieve firing states specified for various primers and the required firing action. The flame length and temperature of the primer output are also important parameters for characterizing the primer output performance. Bai *et al.* [9] introduced a photographic optical

system to measure the length of the flame output of the primer, which cannot be accurately measured using conventional methods. Li *et al.* [10] used high-speed photography to quantitatively measure the length and duration of the flame output of the DJ-6B percussion primer. Peng *et al.* [11] used simulation experiments and high-speed photography to study the output characteristics of a percussion primer and determined the characteristic performance parameters, such as the flame duration, under different operating conditions. Some researchers [12, 13] have used thermocouples to measure the temperature of the primer after impact by a copper sheet to estimate the instantaneous heat flux released by the primer. Chen and Liu [14] found that the combustion temperature of the flame output of the DJ-6B primer measured using a thermocouple was in good agreement with the theoretically calculated value. Liu [15] combined schlieren optics and high-speed photography to measure the detonation flow field of micropyrotechnics and extracted temperature-field parameters from a time series of schlieren images to calculate the temperature field of the micropyrotechnics. A technique for measuring the temperature of micropyrotechnics was thus developed.

The firearm firing-ignition process is a mechanical/thermal/chemical interaction process characterized by several uncertainties. The studies discussed above have mainly focused on the output performance of a single component, the primer. Other influencing factors, the assembly relationship between the primer and the cartridge cases, firing pin, and other components, and the energy transfer and conversion mechanism for the striking of the primer by the firing pin during firing have not been considered. A method for testing the diverse output performance of the firearm firing-ignition system is proposed in this study to provide technical support for the design and performance optimization of the firearm firing-ignition system. The firing pin, primer, and cartridge cases in the firearm firing-ignition system were used as test objects to simulate the real assembly relationship of the firearm firing-ignition system. The real action process of the firearm firing-ignition system was simulated to carry out a diverse output performance test and quantitatively determine various parameters for characterizing the firearm firing-ignition performance, thereby providing data reference and technical support for evaluating the performance and optimizing the design of the firearm firing-ignition system.

2 Experimental and Measurement Principles

The diverse output performance test of the firearm firing-ignition system consisted of measuring the pressure using complete and truncated cartridge cases, as well

as the flame parameters. The environment and operating conditions that affect the output performance of the firearm firing-ignition system were simulated to measure the characteristic parameters, such as the pressure start time, peak pressure, and peak arrival time of the gas output, as well as the length, temperature, and duration of the flame output. A piezoelectric pressure sensor was used to record the gas pressure output of the firearm firing-ignition system, and an accelerometer sensor was used to determine the firing time. The flame parameters were measured using a high-speed camera and an infrared thermal imager to obtain the shape, temperature, and duration of the flame output (more details in Section 3.3.2). A schematic of the versatile output performance test of the firearm firing-ignition system is shown in Figure 1.

2.1 Principle of the measurement test for the gas pressure output

After the primer has been fired, the combustion of the primer mixture generates a flame gas that propagates into the cartridge case through the fire hole. The gas pressure output is an important parameter for characterizing the energy output of the firearm firing-ignition system and a key basis for evaluating the firearm firing-ignition performance. A closed bomb was used to measure the pressure using complete and truncated cartridge cases. The pressure waveform of the gas output in the closed space was measured, and the resulting p - t curve was used to determine the pressure start time, peak pressure, and peak arrival time as the significant characteristic parameters of the output performance.

The gas pressure in the closed bomb is proportional to the temperature and the number of moles of gas contained therein. The maximum pressure generated by the explosion (P_1) of the primer mixture in the primer can be calculated using Equation 1 [16]:

$$P_1 = \frac{T_1 \times m_1}{T_0 \times m_0} \times P_0 \quad (1)$$

where P_0 , T_0 and m_0 are the gas pressure, temperature, and number of moles of gas before the explosion, respectively, and T_1 and m_1 are maximum temperature and number of moles of gas after the explosion, respectively.

The volume of the closed chamber used to measure the pressure was 2.43 and 0.71 cm³ using complete and truncated cartridge cases, respectively, with the primer. According to [17], the gas generated after an explosion has a temperature of 2034.5 K. A calculation based on the theoretical air volume without considering heat loss yields the following theoretical value for the pressure output of the firearm firing-ignition system using complete cartridge cases at an ambient temperature of 298 K (Equation 2).

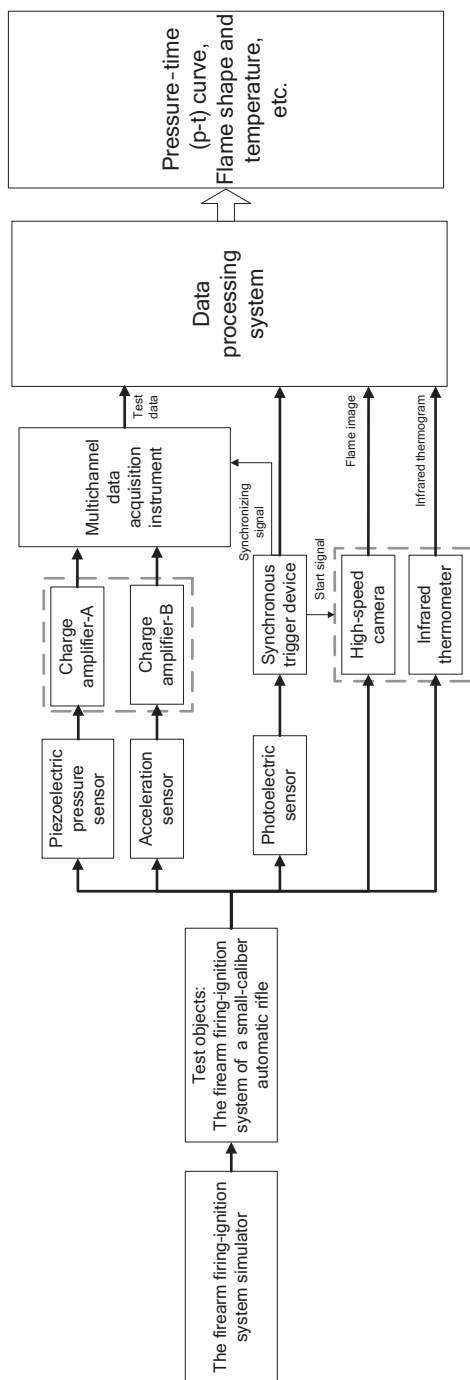

Figure 1. Schematic of the diverse output performance test of the firearm firing-ignition system

$$\frac{2034.5 \times \left(\frac{2.43}{22.4} \times 10^{-3} + 4.55 \times 10^{-4} \right)}{298 \times \frac{2.43}{22.4} \times 10^{-3}} \times 0.1 = 3.54 \text{ MPa} \quad (2)$$

The theoretical value for the pressure output of the firearm firing-ignition system using truncated cartridge cases at an ambient temperature of 298 K is shown in Equation 3.

$$\frac{2034.5 \times \left(\frac{0.71}{22.4} \times 10^{-3} + 4.55 \times 10^{-4} \right)}{298 \times \frac{0.71}{22.4} \times 10^{-3}} \times 0.1 = 10.48 \text{ MPa} \quad (3)$$

2.2 Principle of the measurement test for the flame shape

After the primer was fired, the combustion of the primer mixture generated a flame that propagated into the cartridge cases through the fire hole. Flames are intrinsically transient. A test was carried out using high-speed photography, and image processing was used to determine the flame length and duration as characteristic parameters of the flame shape. The flame duration was calculated as follows:

$$T_f = n/s \quad (4)$$

where T_f is the flame duration, n is the number of pictures containing flame images, and s is the framing rate (in fps) of the high-speed camera.

2.3 Principle of the measurement test for the flame temperature

The flame temperature is an important characteristic parameter for the energy output of the firearm firing-ignition system and a key basis for evaluating the firearm firing-ignition performance. The flame temperature was measured using a noncontact method. The infrared radiation emitted by the flame was captured by an infrared thermometer and converted by software into a visible and quantifiable infrared image, from which the flame temperature output of the firearm firing-ignition system was obtained.

The surface emissivity is one of the basic parameters used to characterize the thermal radiation properties of an object and is a measure of the radiation capability of the material constituting the object [18]. The flame radiation signal used for temperature measurement was mainly produced by the thermal radiation of metal oxide particles, such as lead trinitroresorcinate. These particles can be classified based on their radiation characteristics as a gray body with a specific emissivity of 0.5. According to [19], the temperature T'_0 of such a gray body

measured by a thermal imager can be converted to the true surface temperature (T_0) as follows:

$$T_0 = \left\{ \frac{1}{\varepsilon} \left[\frac{1}{\tau_\alpha} T_0'^m - (1 - \varepsilon) T_\mu^n - \left(\frac{1}{\tau_\alpha} - 1 \right) T_\alpha^n \right] \right\}^{1/n} \quad (5)$$

where T_μ is the ambient temperature, T_α is the atmospheric temperature, ε is the surface emissivity of the object being measured, and τ_α is the atmospheric spectral transmittance. An empirical value of 8.68 is used for n . If the infrared thermal imager is close to the object being measured, it can be considered that $\tau_\alpha = 1$ and that the measured flame temperature is considerably higher than the ambient temperature, namely, T_0'/T_0 is small. Therefore, Equation 5 can be simplified to Equation 6.

$$T_0 = T_0' / \sqrt[n]{\varepsilon} \quad (6)$$

The output flame temperature of the firearm firing-ignition system was measured in this manner.

3 Experimental Methodology

3.1 Test setup

The firearm firing-ignition system simulator used in this study was designed by Zhao [17]. A measurement tool was used to place the test objects, including the firing pin, primer, and cartridge cases, on top of the simulator to simulate the assembly relationship of the firearm firing-ignition system in a firearm. The drop height and mass of the hammer were adjusted to simulate different firing conditions, such that the firing pin stroked the primer with different energies. The firearm firing-ignition system simulator is shown in Figure 2.

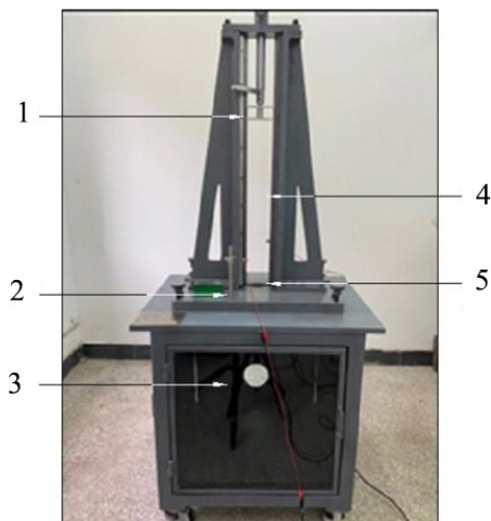

Figure 2. The firearm firing-ignition system simulator: 1 – drop hammer, 2 – working table, 3 – flame observation box, 4 – guide rail, 5 – tool installation hole

3.2 Measurement tool

The firing pin and cartridge cases with the primer were detachably mounted in the holes of a measurement tool on the workbench of the firearm firing-ignition system simulator. The firing pin and cartridge cases with the primer were used as test objects to simulate the assembly relationship and actual operating conditions of a firearm firing-ignition system. The firing pin was assembled in the firing pin hole of a simulated bolt, where the distance between the protrusion and the end face of the simulated bolt was the same as that for an actual forced protrusion. Figures 3-5 show the three different measurement tools that were designed for the test objects with different specifications: separate tools for pressure measurement using complete and truncated cartridge cases and a flame measurement tool. The tool for pressure measurement using complete cartridge cases accurately simulated the real assembly relationship of a firearm, but the large internal cavity volume of the tool resulted in a small measured pressure output. To achieve a desirable measured pressure and improve the measurement accuracy, a tool for pressure measurement using truncated cartridge cases was developed with an internal cavity volume similar to that of a cartridge case with a mounted warhead. The flame measurement tool provided a clear view of the length of the flame ejected from the fire hole.

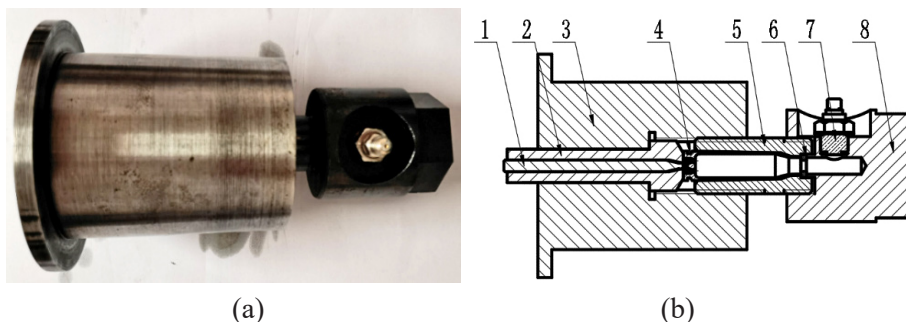

Figure 3. Tool for pressure measurement using complete cartridge cases: 1 – firing pin; 2 – simulated bolt, 3 – installation and positioning tool, 4 – full cartridge case with primer, 5 – simulated chamber, 6 – washer at the mouth of cartridge case, 7 – piezoelectric pressure sensor, 8 – sensor mounting block

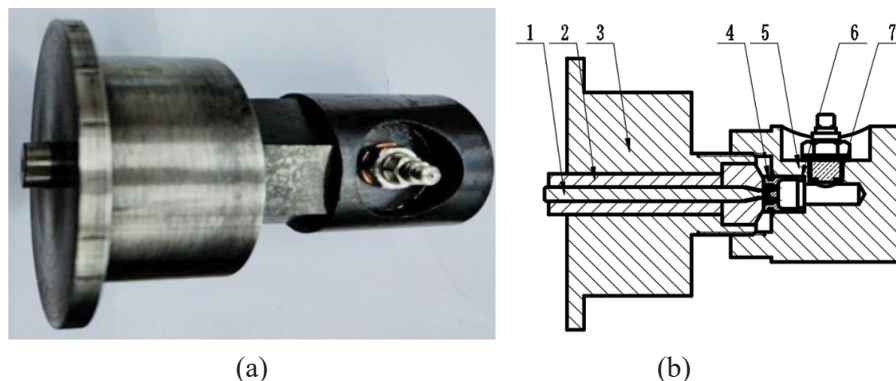

Figure 4. Tool for pressure measurement using truncated cartridge cases: 1 – firing pin, 2 – simulated bolt, 3 – installation and positioning tooling, 4 – truncated cartridge case with primer, 5 – sensor mounting block, 6 – washer at the mouth of cartridge case, 7 – piezoelectric pressure sensor

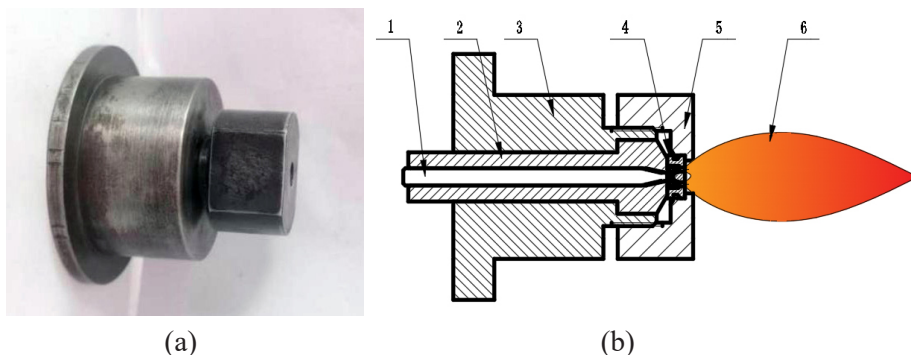

Figure 5. Flame measurement tool: 1 – firing pin, 2 – simulated bolt, 3 – installation and positioning tooling, 4 – truncated cartridge case with primer, 5 – flame observation block, 6 – flame

3.3 Measurement systems

3.3.1 Pressure measurement systems

Different pressure measurement systems were used for the tests on the complete and truncated cartridge cases. Each measurement system consisted of the test objects, the pressure measurement tool, a piezoelectric pressure sensor, a charge amplifier, a multichannel data acquisition instrument, and other devices. During the measurement, the drop-hammer struck the firing pin, at which time an acceleration sensor mounted on the hammer sent a start signal to the multichannel data acquisition instrument. The pressure data that were processed by the piezoelectric pressure sensor were then converted, filtered, amplified, normalized, and modulated by the charge amplifier. The resulting data were collected and finally transmitted to the computer. The pressure measurement systems are shown in Figure 6. The pressure sensor had a sensitivity of 48.2 PC/MPa and ranges of 0-10 and 0-20 MPa for the pressure measurement systems using complete and truncated cartridge cases, respectively.

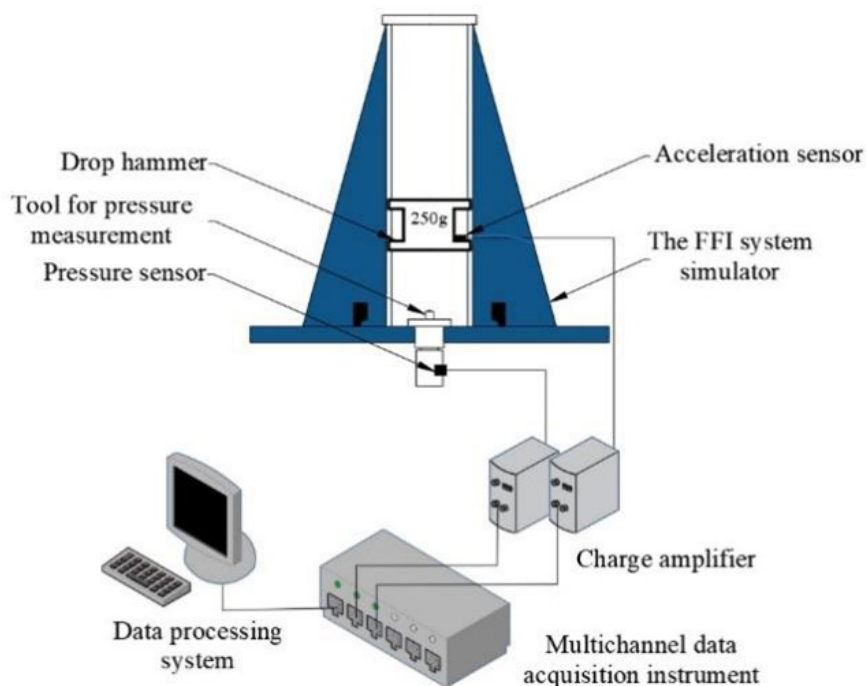

Figure 6. Overall layout of the pressure measurement system

3.3.2 Measurement system for the flame shape and temperature

An open system was used to measure the shape and temperature of the flame output of the firearm firing-ignition system. The flame shape was measured by high-speed photography, and the flame temperature was measured using a noncontact technique. Figure 7 shows the measurement system for the flame shape and temperature, which was composed of the test object, the flame measurement tool, a photoelectric switch, a synchronous trigger device, a high-speed camera, and an infrared thermometer. The high-speed camera was a Phantom VEO 1310 with a resolution of 640×600 pixels and a framing rate of 24,000 fps. The infrared thermometer was a Telops FAST M200 with a resolution of 480×280 . A photoelectric switch was used to generate a start signal during the test to enable the various components of the measurement system to begin data acquisition synchronously.

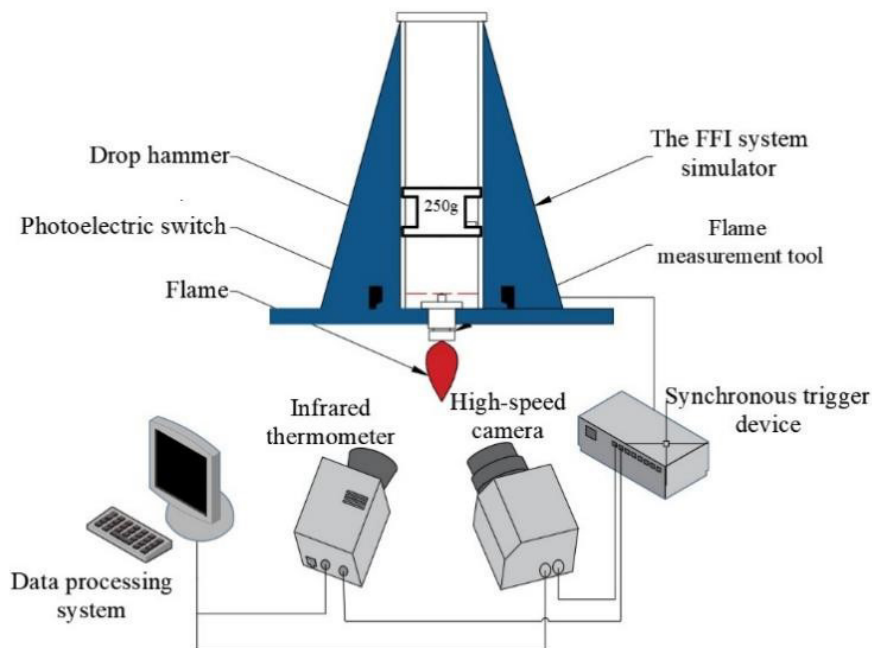
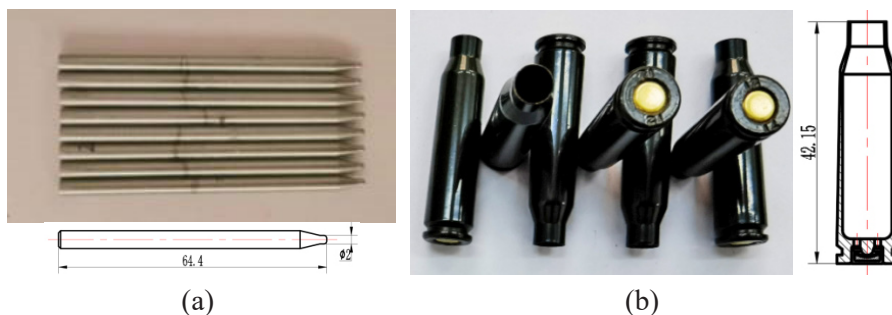

Figure 7. Overall layout of the measurement system for the flame shape and temperature

3.4 Test objects

Figure 8 shows photographs and the main dimensions of the firing pins and the 5.8 mm cartridge cases with the primer of a small-caliber automatic rifle that were used as test objects. Each firing pin had a length of 64.4 mm and a round head with a diameter of 2.0 mm. The pressure was measured using complete and truncated cartridge cases, and the flame was measured using truncated cartridge cases. The primer was loaded to a depth of 0.187 mm in the casings.



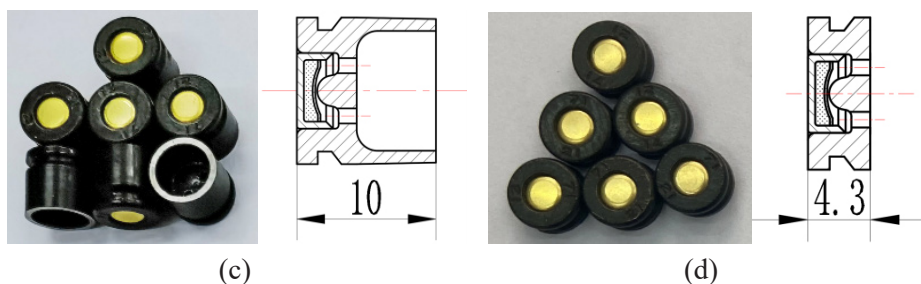

Figure 8. Photographs and main dimensions of the test objects: firing pins used in the tests (a), full cartridge cases with the primer used for pressure measurement (b) and truncated cartridge cases with the primer used for measurements, respectively, pressure (c) and flame (d)

3.5 Test methods

3.5.1 Pressure measurement tests on full and truncated cartridge cases

Each pressure measurement test was carried out by mounting a cartridge case with the primer in the appropriate tool, which was then placed on the firearm firing–ignition simulator. The energy input to the primer was controlled by adjusting the drop height and mass of the hammer. The pressure measurement system was used to determine the firearm firing–ignition output performance under different firing conditions using complete and truncated cartridge cases with the primer. A p - t curve of the primer output was generated and used to determine the pressure start time, peak pressure, and peak arrival time. In Figure 9, the pressure start time (t_1) and peak arrival time (t_2) is related to the moment when the drop hammer strikes the firing pin, which is determined by the signal of the acceleration sensor installed on the drop-hammer. The sudden change of the signal means that the drop-hammer struck the firing pin.

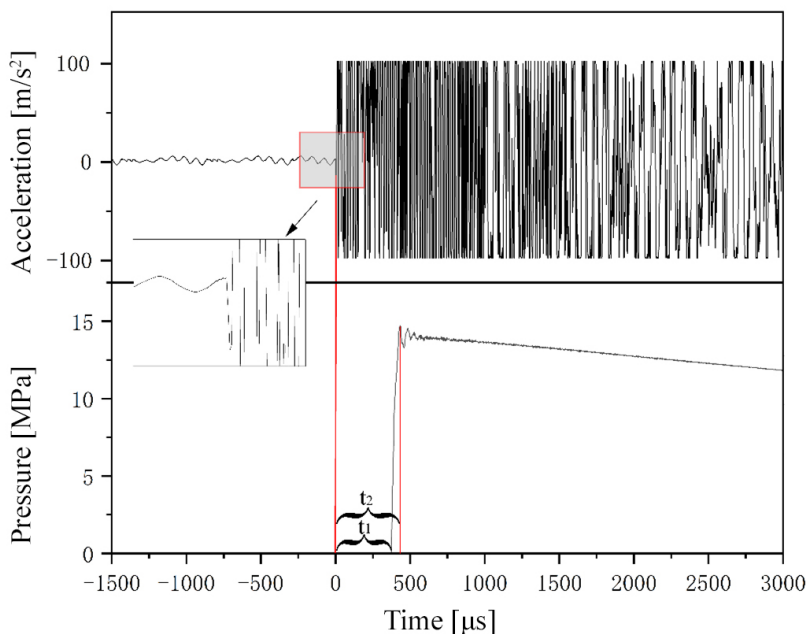

Figure 9. Determining the pressure start time and peak arrival time

To simulate the use of firearms at different ambient temperatures, the pressure measurement tests were carried out at high and low temperatures [20, 21]. The measurement tool, firing pin, and cartridge cases with the primer were placed in an incubator at 50 °C for 2 h in preparation for the high-temperature tests and at -49 °C for 2 h in preparation for the low-temperature tests.

3.5.2 Test for measuring flame parameters

The flame measurement test was carried out by mounting a truncated cartridge case with the primer in the appropriate tool, which was then placed on the firearm firing-ignition system simulator. The energy input to the primer was controlled by adjusting the drop height and mass of the hammer. The measurement system for the flame shape and temperature was used to record various characteristics of the flame output of the firearm firing-ignition system at room temperature, that is, the high-speed camera captured the flame shape and duration, and the infrared thermal imager measured the flame temperature.

4 Results and Analysis

4.1 Pressure measurement tests

4.1.1 Results of the pressure measurement tests on truncated cartridge cases

The pressure measurement system was used to carry out tests on the truncated cartridge cases with the primer. The results of impact sensitivity tests on the primer used for this type of small-caliber bullet indicated that the primer had a firing rate of 50-100%, 98-100%, and 99-100% for a 250 g hammer dropped from heights of 160, 200, and 240 mm, respectively [22]. Based on these results, the firing energy of the firearm was simulated under different conditions of use by dropping a 250 g hammer from heights of 160, 200, and 240 mm at room temperature (25 °C), high temperature (50 °C), and low temperature (−49 °C). A set of 10 rounds of testing was conducted for each condition, totaling nine sets (90 rounds), to obtain the pressure-time curves (p - t curves) of the gas output of the firearm firing–ignition system at different ambient temperatures and under different firing conditions, as shown in Figure 10. Figure 11 shows the average pressure start time, average peak pressure, and average peak arrival time for the specified operating conditions obtained from the p - t curves.

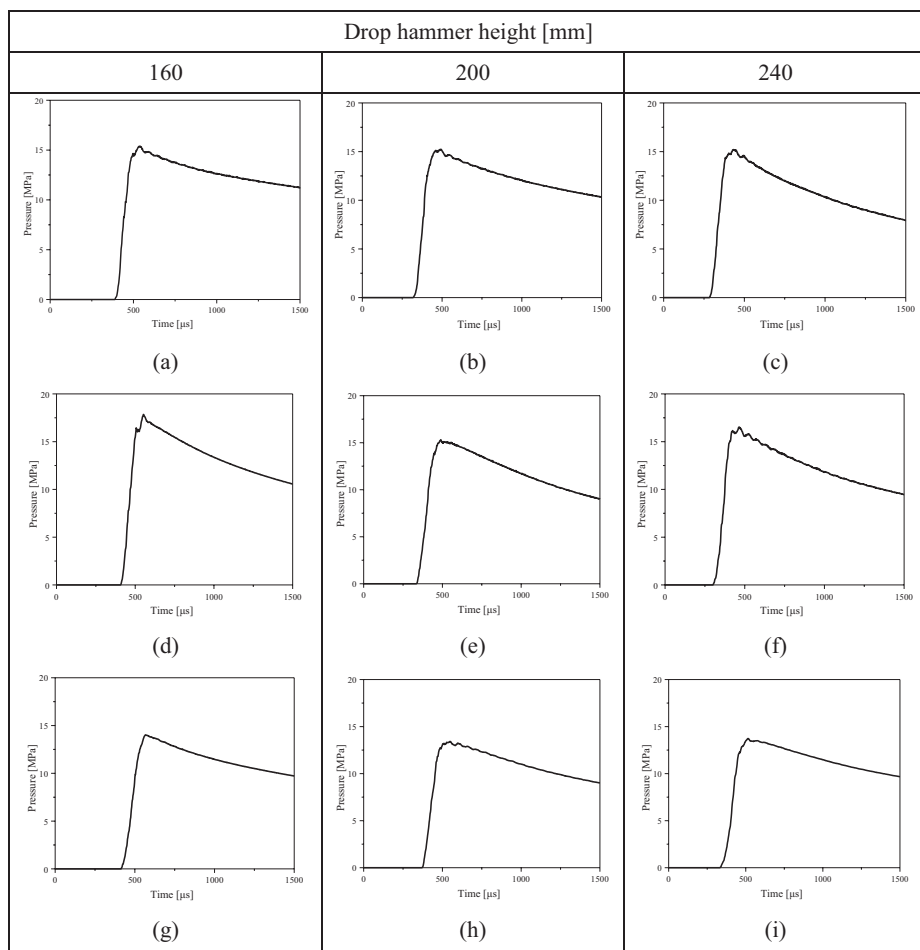

Figure 10. Pressure-time curves of the gas output of the firearm firing-ignition system at 25, 50 and -49 °C ((a)-(c), (d)-(f) and (g)-(i), respectively) and under different firing conditions

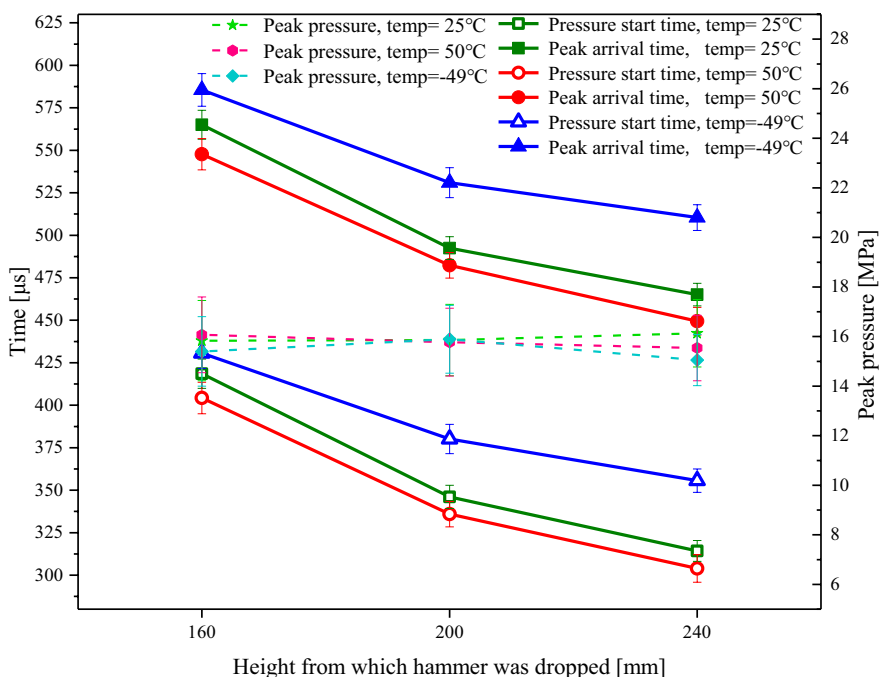

Figure 11. The curve of firearm firing ignition performance changing with firing energy and ambient temperature

The ignition and combustion of the primer mixture generate a flame gas that propagates into the cartridge case through the fire hole. The output gas pressure is an important characteristic of the energy output of the firearm firing–ignition system. Figure 10 shows that the pressure start time and peak pressure arrival time of the gas output varied significantly with increasing firing energy and ambient temperature. At the same firing energy, the higher the test ambient temperature was, the smaller the pressure start time and peak pressure arrival time were. At the same ambient temperature, the higher the firing energy was, the smaller the pressure start time and peak pressure arrival time were.

The peak pressure was not significantly correlated with the firing energy or the ambient temperature. However, the peak pressure output decreased significantly in the low-temperature environment, probably because the rate of combustion of the primer mixture was reduced in this environment. The pressure measured in the test was higher than that calculated in Section 1.1. This result was obtained because during the test, the combustion of priming mixtures leaves a lot of solid residues. So, the cavity in the tool was covered by solid residues of the priming mixture. Therefore, the cavity was cleaned after every five rounds.

4.1.2 Results of pressure measurement using full cartridge cases

The pressure measurement system was used to carry out tests on the complete cartridge cases with the primer. A 250 g hammer was dropped from heights of 160, 200, and 240 mm to strike the firing pin with different firing energies at room temperature (25 °C). One set of 10 rounds was measured under each test condition, totaling three sets (30 rounds).

Table 1. Variation in the pressure start time, peak arrival time, and peak pressure with increasing firing energy

Drop-hammer weight [g]	Height from which hammer was dropped [mm]	Average pressure start time [μ s]	Average peak pressure [MPa]	Average peak arrival time [μ s]
250	160	620	4.688	724
	200	519.6	4.052	642.4
	240	465.2	4.153	580.2

Table 1 shows that the same trend was obtained using the complete and truncated cartridge cases with the primer for pressure measurement, that is, both the start and peak arrival times of the pressure output of the firearm firing-ignition system decreased with increasing firing energy. However, for structural reasons, the pressure sensor on the tool used for the complete cartridge cases was mounted further away from the fire hole in the casing than that on the tool used with the truncated cartridge cases. Thus, the pressure start time and peak arrival time measured using the complete cartridge cases lagged behind those measured using the truncated cartridge cases.

4.2 Tests used to measure the flame shape and temperature

The 250-g hammer was dropped from heights of 160, 200 and 240 mm at room temperature (25 °C), and 10 rounds of tests were carried out for each set of operating conditions.

4.2.1 Flame shape measurement results

Figure 12 shows the development of the flame shape output of the firearm firing-ignition system captured by the high-speed camera during the test. The time interval for each photo is 41.67 μ s. The first photo corresponds to 457 μ s after the drop-hammer struck the firing pin (one experiment of a 250 g hammer dropping from heights of 240 mm). Table 2 shows the firing times and flame sizes determined from the test data.

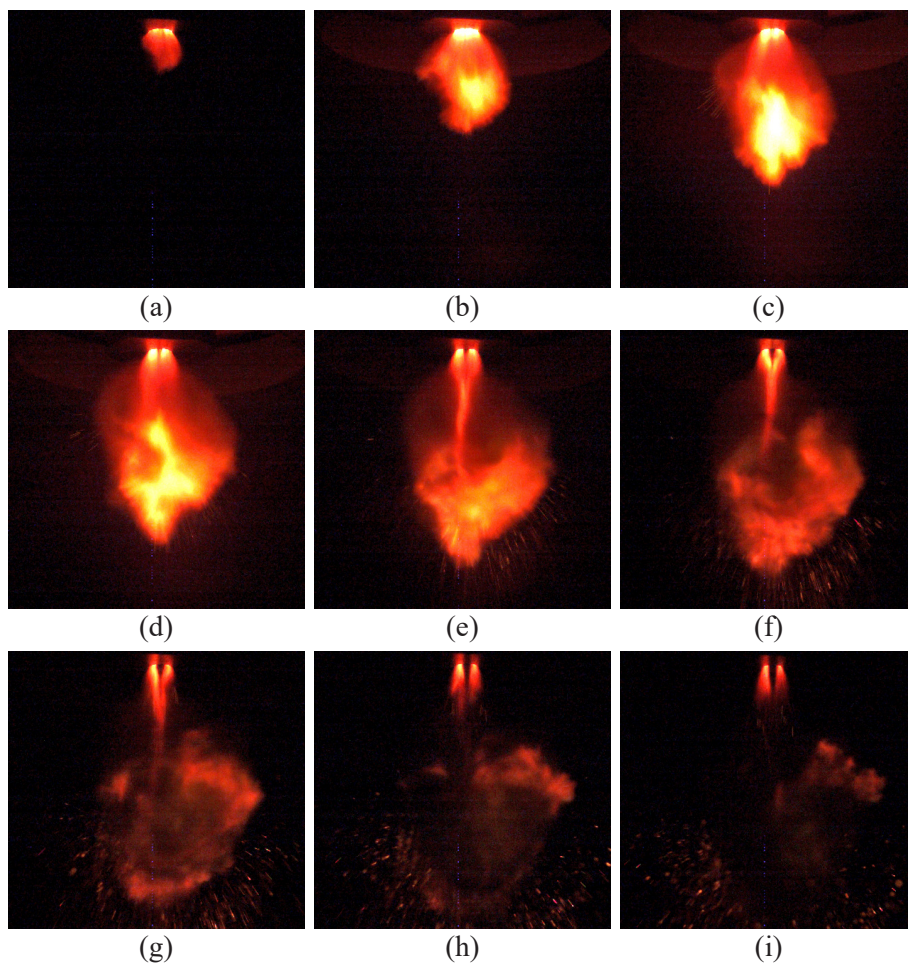

Figure 12. Development of the flame shape output

Table 2. Influence of the hammer drop height on the flame shape and duration

Drop-hammer weight [g]	Height from which hammer was dropped [mm]	Average maximum [mm]	Average maximum width [mm]	Flame duration [μ s]
250	160	65.30	40.83	349.94
	200	64.30	35.79	354.11
	240	68.85	40.83	416.60

Figure 9 shows that there were four stages in the development of the flame shape output:

- Early ignition: Immediately after the ignition of the primer mixture, an ellipsoidal flame erupted from the fire hole.
- Intense flame: Vigorous combustion occurred, during which the flame had a rhombic or columnar shape and was generally 30-40 mm long.
- Flame development: The flame expanded to its maximum length and width, where the flame length generally ranged from 60 to 70 mm.
- Flame attenuation: The flame was cluster-shaped and dissipated slowly, appearing sporadically in the fire hole and then gradually disappearing.

The length and duration of the flame are important parameters for characterizing the ability of the primer to ignite the propellant [23]. Table shows that the length and duration of the flame output by the firearm firing–ignition system generally increased with increasing firing energy, whereas the flame width was not significantly correlated with the firing energy.

4.2.2 Flame temperature measurement results

Figure 13 shows the flame temperature output, as measured by the infrared thermal imager, at different stages. The temperature of the flame output could be simply categorized into the four stages for the flame shape:

- (1) During early ignition, the ellipsoidal flame ejected from the fire hole had a maximum temperature in the range of 650-740 °C.
- (2) During the intense flame stage, the flame had a prismatic shape with a maximum temperature ranging from 1087 to 1218 °C.
- (3) During flame development, the approximately columnar flame had a maximum temperature in the range of 840-960 °C.
- (4) During flame attenuation, the flame began to dissipate and was approximately ellipsoidal with a maximum temperature range of 240 to 340 °C.

The temperature of the flame output was approximately 1000 °C and reached a maximum of 1218 °C during the second stage. Figure 13 shows highlighted areas at the head and tail of the flame, corresponding to the core areas of the high-temperature flame. The highest temperature was found at the flame head near the fire hole, and the temperature of the highlighted area at the flame tail was slightly lower than that (approximately 450-600 °C) at the flame head. The high temperature at the flame tail was the result of secondary combustion of the residue of the primer mixture that was ejected with the flame.

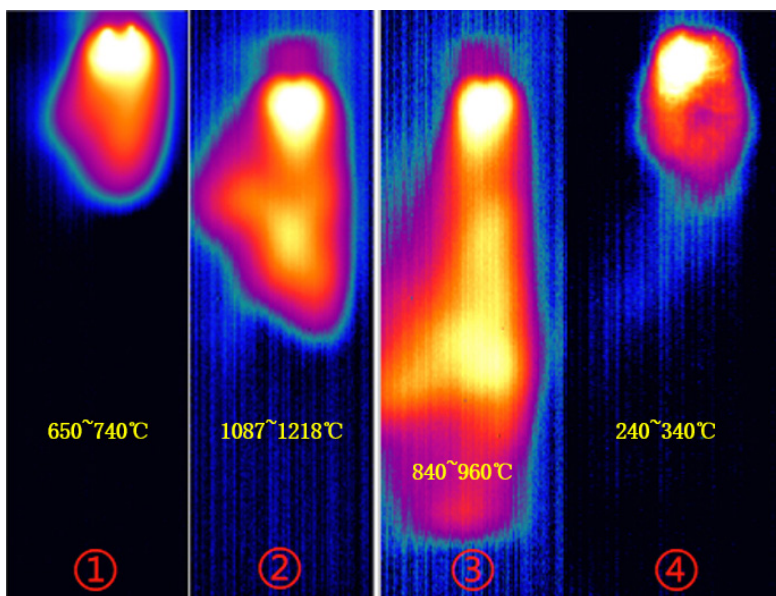

Figure 13. Infrared thermal images showing four stages of flame development

5 Conclusions

In this study, a firing pin and cartridge cases with a primer were used as test objects, and a scheme was developed for testing the performance of the firearm firing-ignition system output. The proposed method was used to carry out tests to determine the characteristic parameters of the primer output of the firearm, and the following main conclusions were drawn:

- ◆ The proposed method for testing the diverse output performance of the firearm firing-ignition system uses a firing pin, primer, cartridge cases, and a tool to simulate the real assembly relationship of firearms. Thus, diverse system output data can be effectively extracted, successfully solving challenges in experimentally observing the transient, highly dynamic firearm firing-ignition process in a small and invisible action space with uncontrolled energy. The proposed test method was used to study the output performance of the firearm firing-ignition system, and effective means were employed to supplement existing methods for testing ammunition with a primer, providing a data reference and technical support for mechanistic research, theoretical modelling, performance evaluation, and design optimization of the firearm firing-ignition system.

- ◆ The test results demonstrated that the primer pressure output by the firearm firing-ignition system depended strongly on the energy received by the primer. Within a certain range of firing energies, the higher the firing energy was, the more rapidly gas was output from the firearm firing-ignition system, as manifested by lower pressure start and peak arrival times of the gas output. The ambient temperature also influenced the primer pressure output: the higher the ambient temperature was, the lower the pressure start time and the peak arrival time were. The peak pressure of the primer output was lower at a low ambient temperature than at a high ambient temperature, indicating that low temperature directly degraded the system performance.
- ◆ At room temperature, the flame length and duration of the primer output generally increased with increasing firing pin energy. The flame duration of the primer output was approximately 300-400 μs and increased with the firing energy. There were four stages in the development of the flame shape and temperature of the primer output in the firearm firing-ignition system. The maximum flame length (reaching up to 60-70 mm) occurred during the third stage. The highest flame temperature of 1218 $^{\circ}\text{C}$ was reached during the second stage.

Acknowledgements

The authors gratefully acknowledge Chongqing Changjiang Electrical Appliances Industries Group Co. Ltd. and No. 208 Research Institute of China Ordnance Industries for partial support of this work.

References

- [1] Li, Z. *Reliability Analysis and Research of Firearm Firing-Ignition System*. M.E dissertation, North University of China, Taiyuan, China, **2022**.
- [2] Wu, Z.L. *Small Arms Ammunition*. Beijing Institute of Technology Press, Beijing, China, **2019**.
- [3] Valenta, F.J.; Dalton, A.J. Comparison of Several Techniques to Evaluate Percussion Primer Performance. *Proc. 29th Int. Pyrotech. Semin.*, Westminster, US-CO, **2002**, 383-390.
- [4] Bi, W.H.; Liu, S.; Yan, N. Application of Closed Bomb in Testing Output Performance for Explosive Actuated Devices. *Metrol. Meas. Tech.* **2008**, *7*: 1-3.
- [5] Liu, D.Y.; Zhao, Z.Y. Closed Bomb Test and Numerical Calculation on the Combustion of Mixture of Deterrent Coated Propellants and Traditional Propellants in Closed Vessel. (in Chinese) *Chin. J. Explos. Propellants* **2011**, *34*(4): 83-86.
- [6] Wang, L.X.; Dai, Y.; Wang, J.G.; Zhang, X.W. Experimental Study on Influence of

- Initial Temperature of Primer on Energy Release Characteristics. *J. Ballist.* **2022**, 34(2): 106-110.
- [7] Wang, L.F.; Wan, X.Y.; Yi, F.; Xiao, S.M. The Testing Device of Cartridge's Primer and Testing Method. (in Chinese) *Chin. J. Explos. Propellants* **2001**, 4: 52-53.
- [8] Liu, W.Q.; Cai, R.J.; Wen, Y.Q. The Measurement System of Pressure-Temperature for Primers. *J. Test Meas. Technol.* **2007**, 5: 377-381.
- [9] Bai, B.; Liu, C.J.; Xi, L.X. Application of Image Technology to Flame Length Measuring of Ignite. (in Chinese) *Initiators Pyrotech.* **2011**, 4: 44-46.
- [10] Li, B.; Zhuang, H.W.; Zhang, R. A Test Platform for the Output Performance of Percussion Primer. (in Chinese) *Initiators Pyrotech.* **2014**, 6: 44-46.
- [11] Peng, J.B.; Wei, L.; Wang, X.Y. Output Characteristics of a Non-primary Explosive Percussion Primer. (in Chinese) *Chin. J. Explos. Propellants* **2019**, 27(9): 779-785.
- [12] Evans, N.A.; Brezowski, C.F. *The Effect of Charge Mixture Ratio and Particle Size on Igniter Plume Heat Transfer Characteristics*. Sandia National Laboratories Report SAND90-0230C, Albuquerque, US-NM, **1990**.
- [13] Yong, L.V. *An Evaluation of Temperature and Heat Flux of Gasless and Gassy Percussion Primers*. Defense Science and Technology Organization, Report MRL-R-971, AD-A164699, Australia, **1985**.
- [14] Chen, M.H.; Liu, W.Q. Determination and Calculation of the Burning Temperature for DJ-6B Primer Compositions. (in Chinese) *Chin. J. Explos. Propellants* **2006**, 2(14): 129-131.
- [15] Liu, R.M. *Research on Testing Technology of Temperature Field of Micro-Pyrotechnics*. M.E Dissertation, Xi'an Technological University, China, **2021**.
- [16] Li, D. Discussion on Maximum Explosive Pressure of IIC Flameproof Electric Apparatus. *Electric Switchgear* **2012**, 6: 101-103.
- [17] Zhao, C.C. Design of Simulation Test Device for Firing System of Firearms. (in Chinese) *Ordnance Industry Automation* **2022**, 41(4): 10-18.
- [18] Hu, J.H.; Nin, F.; Shen, X.H.; He, G.X. Influence of Surface Emissivity of Objects on Measuring Accuracy of Infrared Thermal Imagers. *Chin. J. Opt. Appl. Opt.* **2010**, 3(2): 152-156.
- [19] Yang, L. Calculation and Error Analysis of Temperature Measurement Using Thermal Imager. *Infrared Technol.* **1999**, 4: 20-24.
- [20] GJB 1247A-2006 *General Specification for Cartridge*. (in Chinese) China, **2006**.
- [21] GJB 3653.3-2002 *Regulation for Inspection and Acceptance of Initiating Explosive Devices Artillery Primer*. (in Chinese) China, **2002**.
- [22] WJ2644-2005 *General Specifications for Cartridge Primer*. (in Chinese) China, **2005**.
- [23] Huang, H.K. Several Output Energy Measurement Methods of Primer. (in Chinese) *Initiators Pyrotech.* **2004**, 3: 47-494.

Received: June 19, 2023

Revised: December 13, 2023

First published online: December 21, 2023