

KRZYSZTOF KRASUCKI  
TOMASZ KUDŁACIK  
KRZYSZTOF AUGUSTYNIAK

# RUFUS 3G load bearing capacity monitoring system for providing diagnostics for powered roof support operations

*The Ziemowit part of the Piast-Ziemowit mine uses an active and passive load bearing capacity system for its powered roof support section, which allows for diagnostics, the selection of initial load bearing capacity, and control of the roof's impact on the longwall support.*

*The diagnosis of powered roof support section operations by means of the load bearing capacity monitoring system shortens the search for faults. In underground conditions, it is difficult to diagnose failures related to the operation of the powered support, however, the mine is able to detect any irregularity on the mine's surface by qualified energomechanical dispatchers. The need to ensure contact between the support and the rock mass at the stage of operation is the basic criterion for the functioning of the works performed. Controlling the situation in the longwall related to the limited amount of falling roof rocks is an advantage of the proper use of the load bearing capacity monitoring system by employees.*

*Key words: monitoring of load-bearing capacity, load bearing capacity, roof stability*

## 1. INTRODUCTION

---

In the Ziemowit part of the Piast-Ziemowit mine, an active resistance system for the powered support section was used in longwall no 922, which allowed for the automatic setting of powered support sections and the selection of initial support, as well as the control of the roof's impact on the longwall support sections.

The system, which modernized the approach to performing diagnostics on longwalls in the Piast-Ziemowit coal mine, was developed and implemented by the mine management team.

An innovative method of diagnosing the operation of powered support sections by means of IT systems shortens the time needed for repairs or finding defects, and the selection of prophylaxis in the event of a risk of interrupting the roof continuity. In under-

ground conditions, it is difficult to diagnose failures related to the operation of powered support. The mine, through qualified energomechanical dispatchers, is able to find irregularities at their source.

The contact of the canopy of the powered support section with the rock mass during operation is the basic criterion for the performance of works. The sizing of parts of the direct ceiling in the form of rock fragments, rock clods or rock blocks, resulting in the formation of free spaces, leads to unfavorable downtimes in operation and dangerous work related to securing the roof of the longwall excavation. Therefore, it is crucial to control the situation in the wall related to the limited amount of roof rock fall by monitoring the support load bearing capacity and the proper installation of the powered support section by means of the monitoring system. Due to the correct support control in the 922 wall, there was no fall of

roof rocks which caused the longwall to stop operations. Longwall 922 exploited seam 209, 3.1 m high, 195 m long face, and the total life of the longwall was 1,570 m.

The longwall was equipped with 129 ZRP-15/35-POz powered support sections (Tab. 2), which was the total length of the longwall face 195 m, and the total life of the longwall 1570 m.

**Table 1**  
**Characteristics of hazards in wall 922**

The type of hazard	The level of hazard
Coal dust explosion hazard	Class A
Methane hazard	none
Gas and rock outbursts hazard	none
Radioactive substances hazard	none
Climatic conditions hazard	none
Fire hazard	IV group of self-ignition
Flooding hazard	1st degree
Rock bursts hazard	1st degree

**Table 2**  
**Basic technical parameters of the ZRP-15/35-POz section**

Parameters	Value	Unit
The working range of the support in insusceptible to rock-bumps seams	1.7–3.4	[m]
Support center	1.5	[m]
Roof support advance	0.8	[m]
Initial load capacity of props (for 30 MPa)	2 · 2120	[kN]
Working capacity of props (for 43 MPa)	2 · 3039	[kN]
Set working load capacity (for 43 MPa)	4277–5801	[kN]
Average unit pressure on the bottom	1.537–2.083	[MPa]
Average unit pressure on the ceiling	0.988–1.339	[MPa]
Supply pressure	25–30	[MPa]
Mass	~21000	[kg]

The stability of an excavation is often referred to as its ability to maintain its shape and location despite the forces acting on the excavation [1]. Proper maintenance of excavation stability allows for continuous exploitation and the removal of breaks caused by the precipitation of roof rocks (Fig. 1). One of the ways to control the stability of excavations is the use of a longwall support monitoring system (Figs. 2 and 3), which allows the detection of operator neglect when building a powered support section. The Piast-Ziemowit mine, in order to ensure appropriate conditions in the longwall and the immediate detection of hydraulic

faults, appointed a person responsible for monitoring the longwall's condition. The supervision of the mine management over the monitoring system in the longwall has had a significant impact on the improvement of the wall support capacity, the lack of longwall breaks due to falling roof rocks [2] or the failure of the powered support section, which precludes it from further operation. Bad roof construction could cause a long-term falls of rocks and ultimately lead to the collapse of the wall. The correct reaction of the mine management allows for the continuity of extraction, without worsening the ceiling conditions in the wall.

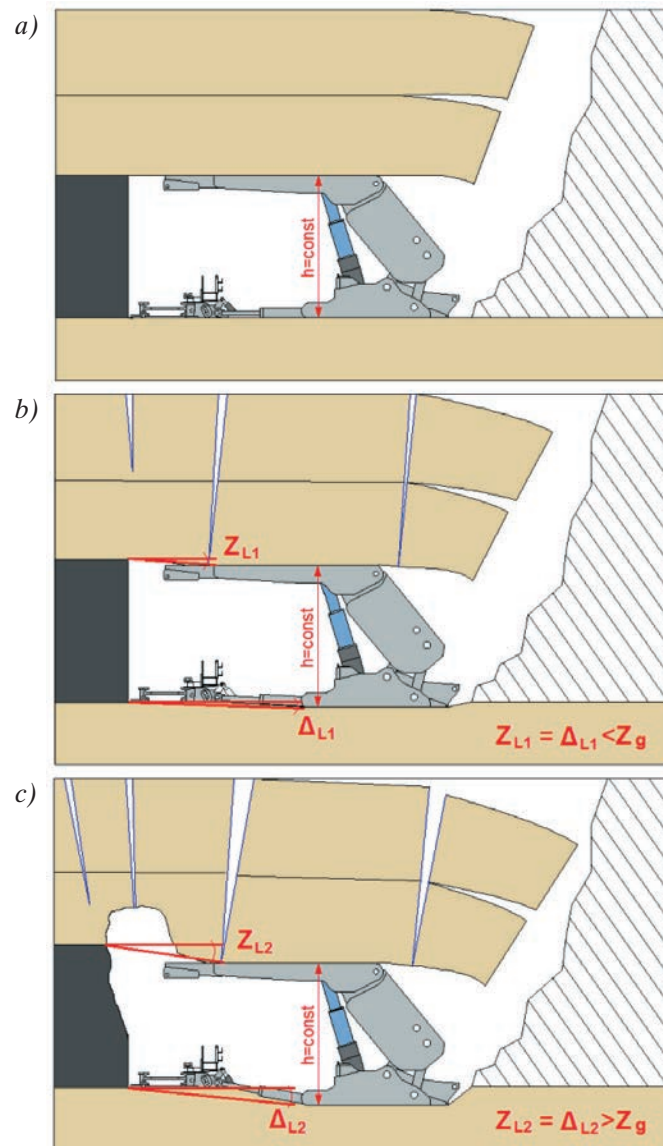

Fig. 1. The longwall ceiling maintenance: a) properly maintained ceiling; b) good ceiling conditions, unit inclination lower than the ceiling boundary inclination; c) deteriorated maintenance conditions of the ceiling, unit inclination greater than the boundary inclination [1]

### The longwall before *in situ* control

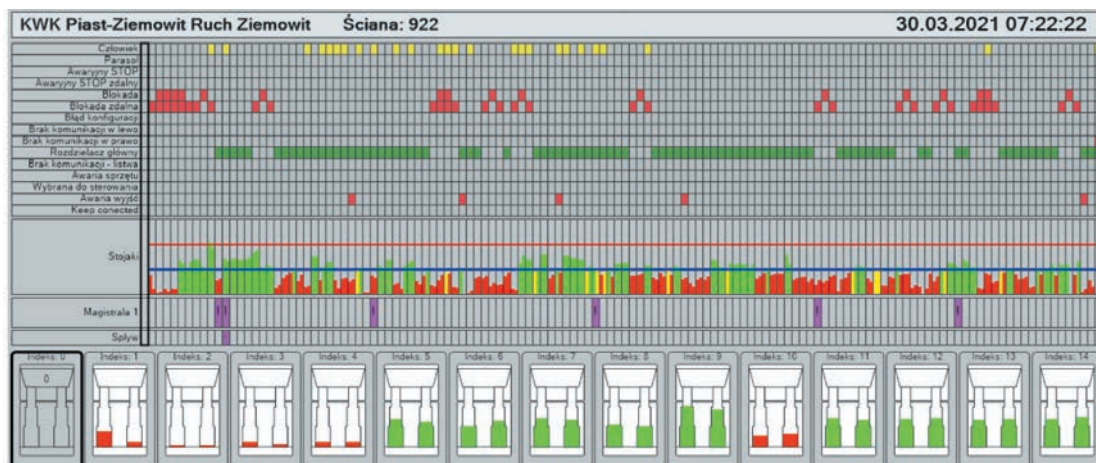

Fig. 2. View of the support monitoring system in the longwall – incorrect support load bearing capacity

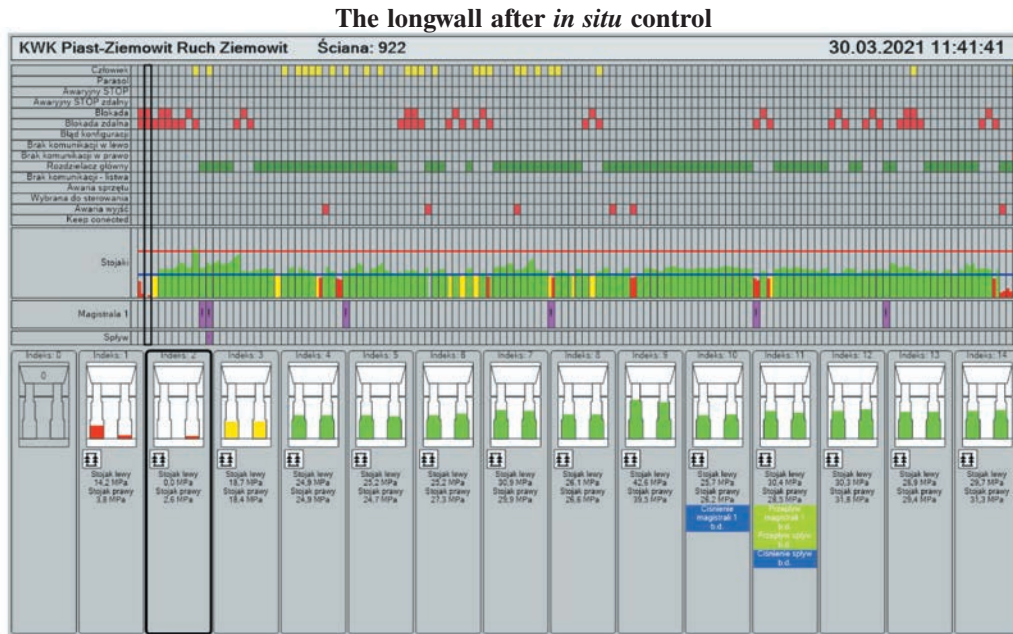

Fig. 3. 3D diagram of pressure distribution in the longwall during stop

## 2. THE WORKING PRINCIPLES OF POWERED SECTION LOAD BEARING CAPACITY MONITORING SYSTEMS

The system supporting the operation of the powered support section in terms of the correct support of the longwall roof and the diagnosis of the correct operation of hydraulic props allows for direct control by employees working on the longwall.

Energy-mechanical dispatchers carry out inspections from the mine's surface and check the correct operation of the props of the powered support section on an ongoing basis. They are able to catch any faults at an early stage of their development.

The energy-mechanical dispatcher has an overview of the pressure distribution in the wall through sensors installed in the powered support sections, which collect data on the pressure distribution and create visualizations. The system informs the dispatcher about overly low or high pressure of the medium in the hydraulic props and allows the determination of the course of the pressure in the props.

From the monitoring systems, two basic types of functioning can be distinguished, a passive and an active monitoring system. The mine first used an active monitoring system for the powered support section, which is the most widespread in the Ziemowit part, and currently the mine is testing the functioning of a passive system in longwall 501, from which the advantages and disadvantages of the systems will be developed.

A passive system of support for a powered support section is characterized by focusing more attention on the support condition in the longwall. This system does not automatically recharge the pressure to the props of the powered support section: the user has to take care of the situation related to the pressure distribution in the longwall. The Piast-Ziemowit mine currently uses a passive monitoring system in longwall 501 which is exploiting seam 215.

The active support system of the powered support section automatically diagnoses and, if necessary, regulates the pressure in the section props. The Ziemowit mine uses an active system and the key elements for the powered support section used in the mine are the  $\mu$ RUFUS pressure maintenance sensors, which include:

- electronic and electrical equipment,
- a hydraulic block controlled by a solenoid valve,
- hydraulic valves,
- transmission wires.

The built-in solenoid valve (Fig. 4) controls the pressure of the stand and, in the event of overly low pressure being applied to the hydraulic prop by the operator, the support system is automatically activated and the support condition of the powered support section is corrected.

The system is very intuitive and employees working on the wall are able to recognize the problem and solve it themselves.  $\mu$ RUFUS sensors are installed on each section, which indicate the correct or incorrect



expansion of the section. Observation of the correct operation of the powered support section in the longwall is very simple: the sensor displays a green color, indicating that the prop has been properly built-in, or a red color, which indicates that the powered support section has been incorrectly expanded. In addition, the DPS-200 controller is equipped with a visual control system that signals the support status in the props currently connected to the sensor on an ongoing basis.

The longwall 501 currently exploited in seam 215 (Fig. 5) at the level of 500 m (below surface) is equipped with a system of passive support control of the powered support section. The passive support system is more difficult for the operator, since they

have to spend more of their working time on the separation of the powered support section in order to properly expand the canopy.

The sensor (Fig. 6) installed in the powered support section shows the support condition of the left and right props. The signal from the sensors is sent to the visual panel of the device status, which displays the situation in the props with a light signal. The system sends signals to IT systems that allow operator to display the longwall status in computer programs. Additionally, the computer installed in the accessory kit suspended on the monorail track at the bottom road allows a preview of the sensors built into the longwall.

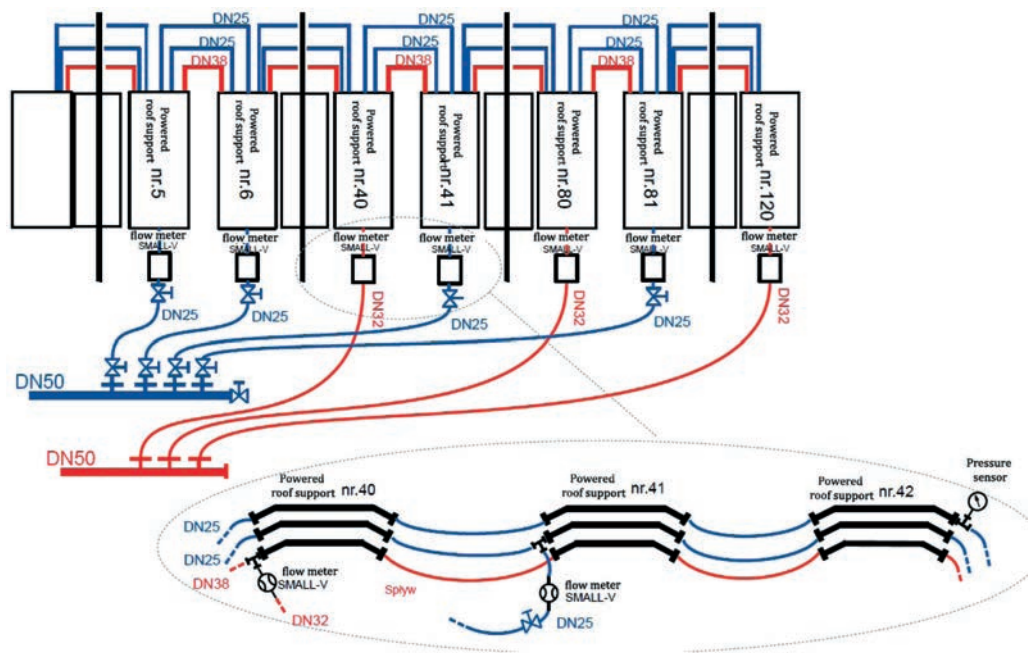

Fig. 4. Block diagram of pressure and flow measurements [2]

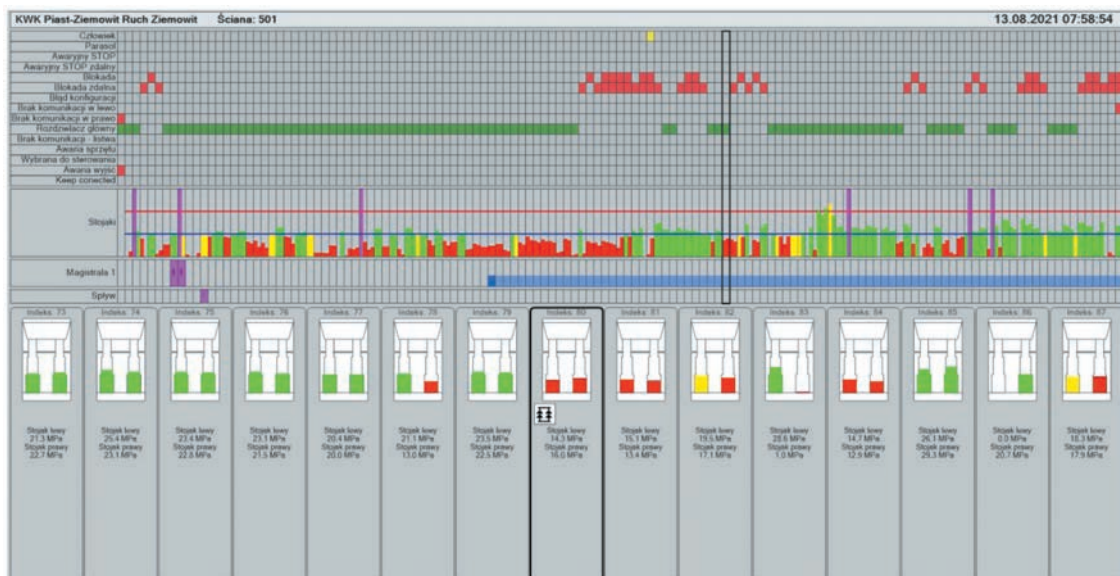

Fig. 5. The state of support in the longwall 501 without the active system applied

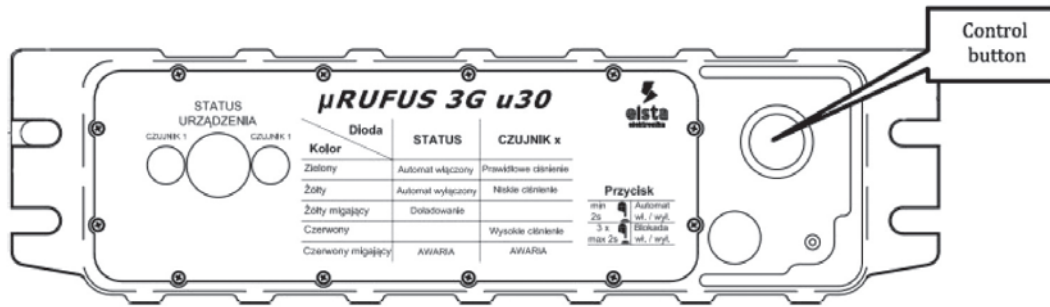

Fig. 6. View of the front panel of the controller on the powered support section [2]

### Marking of visual signals RUFUS 3G of rack sensors (Fig. 4) [3]

- Constant green signal – correct pressure in the range from 20 MPa to 35 MPa.
- Constant yellow signal – initial load capacity has not been achieved, overly low pressure in the range from 0 MPa to 20 MPa.
- Constant red signal – overly high pressure range exceeding 35 MPa.
- Red signal with single blinking – solenoid valve not connected or short circuit in the cable or damage to the solenoid valve.
- Red signal with double blinking – sensor damage, disconnected sensor, or short circuit in the sensor cable.

### Marking of visual signals RUFUS 3G signaling status (Fig. 4) [3]

- Yellow signal – correct operation of the sensor, the pressure boost function is disabled.
- Yellow signal blinking with a sound signal – solenoid valves may cause section movement.
- Green signal – correct operation of the sensor, the pressure boost function is on.
- Continuous red signal – emergency button in the control panel activated.
- Red signal with a single blink – system or hardware failure, it is recommended to enable or disable the sensor.
- Red signal with a double blink – software failure, contact with the manufacturer is recommended.
- Red signal with a triple blink – the maximum number of recharges of the supports in the powered support section has been reached, but the pressure has not been obtained and the controller will not retry another attempt.
- Blinking pink signal – system update.

### 3. READING DATA FROM SYSTEMS – FAULT DIAGNOSIS [4]

The current state of the situation in the longwall is illustrated by the pressure measurement (Fig. 7). The user is able to analyze the data without any problems, as it is possible to generate an accurate graph of the pressure course (Fig. 8).

From the graphs generated by the software monitoring the operation of the powered support section, a large amount of information can be obtained, not only data from the current condition of the longwall, but also historical data that allows the display of the condition of the longwall from several weeks or months ago. The diagram of operation (Fig. 8) of four selected sections of powered support is illustrated by the diagram of eight waveforms of pressure distribution in the section props. It is easy to discern that at point 1 there was a production cycle in the longwall, followed by the installation of the powered support section (shearer cutting and driveway in sections), while point 2 shows the correct pressure increase after the installation of the powered support section. Points 3 and 4 show the diagnosed faults. The fault from point 3 concerns the damage to one of the props of the powered support section, and the fault from point 4 concerns the damage of the prop sensor. The graph depicted in this way allows the operator to detect failures from the level of the energy-mechanical control room.

The software also allows the generation of 3D diagrams (Fig. 9), from which the operator can see the distribution of ceiling stresses on the longwall. The diagram below shows the longwall during the third day of production stoppage. The pressures do not increase to the ranges above 50 MPa due to the functioning of the relief valves in the wall.

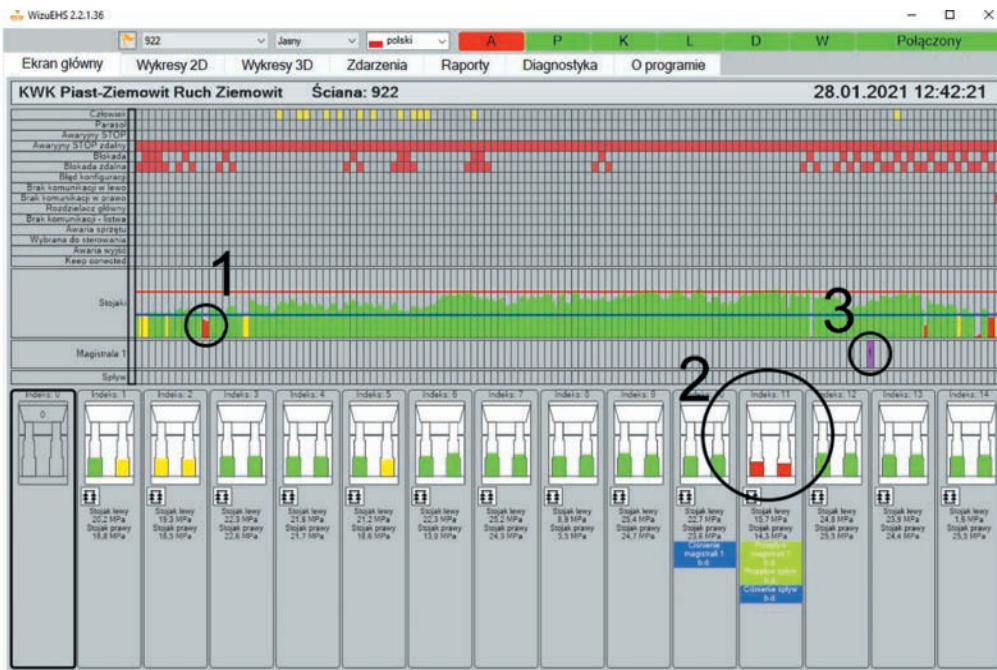

Fig. 7. View of the main software screen: 1 – incorrectly expanded powered support section; 2 – visual condition of powered support section; 3 – failure of a sensor in one of the section stands

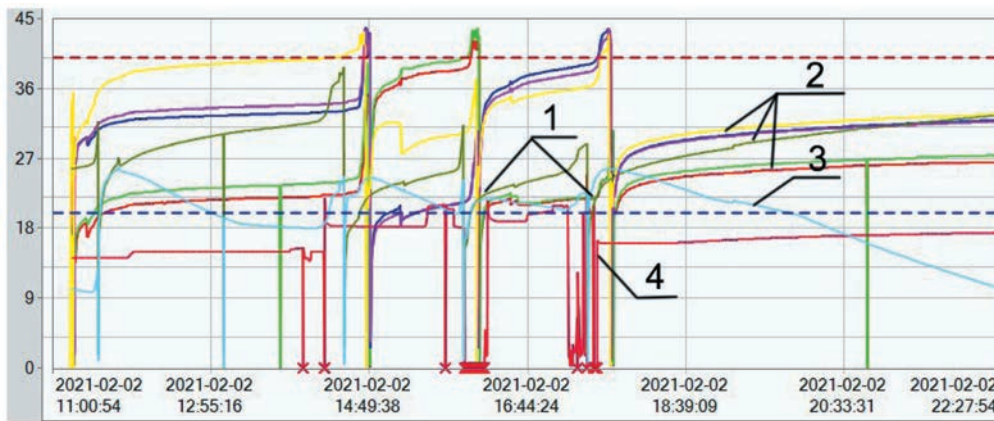

Fig. 8. Diagnostics of hydraulic props through 2D charts

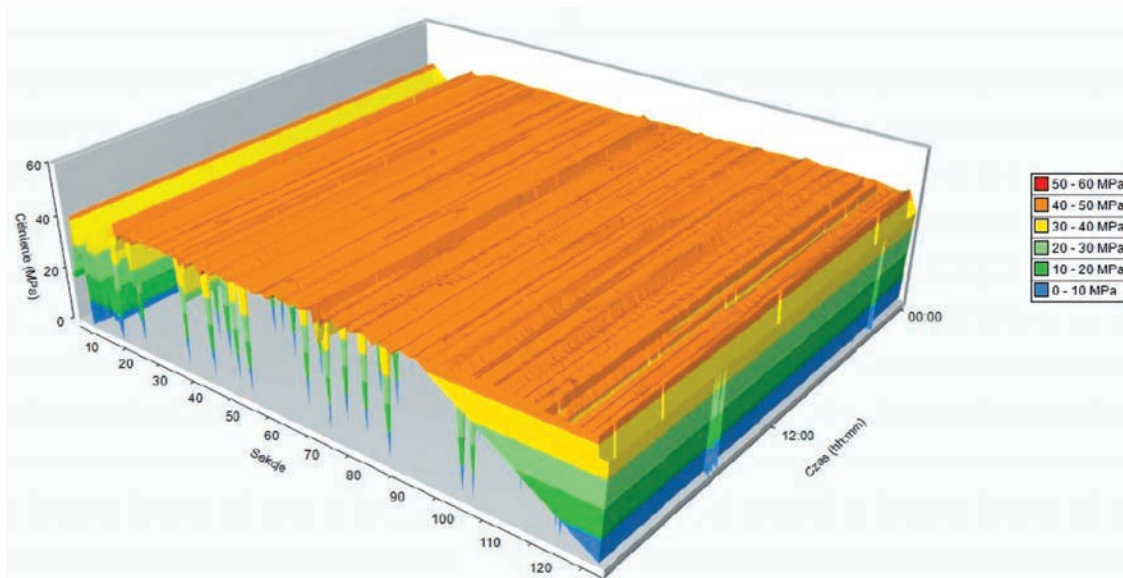

Fig. 9. 3D diagram of pressure distribution in the longwall during standstill



The three-dimensional report is an image where an operator can analyze how the longwall production cycle proceeded and at which times the longwall shearer was in operation. The above report is an image of the graphs with the coordinates X, Y, Z.

The X coordinate is assigned to the powered support section, the Y coordinate is the pressures in the supports of the powered support section displayed in megapascal, and the Z coordinate is responsible for the time period. During its normal production cycle, the longwall is characterized by a constant changeability of the pressure distribution in the longwall, everything is caused by the continuous advances of the powered support section as well as the operation in the area of the monitored section.

The monitoring system allows the accurate determination of the place where the longwall shearer is located, and it is also possible to read the impact of the recourse pressure of the section of the powered support, which is transferred to the adjacent section.

#### 4. THE PROBLEM RECOGNITION ALGORITHM

The diagnosis of a prop defect at the mine surface causes the initial identification of the problem that has arisen and which must be thoroughly examined in the longwall itself at a later stage.

The developed scheme of operation during the diagnosis of the cause of the fault or damage is as follows:

1. Noticing a situation in the monitoring systems in which there was a connection loss, continuous low pressure or pressure drops noticeable in the long term.

2. Referring an employee of the mechanical department located in the longwall to check the cause and visual condition of the sensor and the stand of the powered support section.
3. In the absence of faults, referring an employee of the teletechnical department to check the correct operation of the sensor.

The previously presented steps of checking the detected fault are commonly used, with the most common problem related to faults being sensor related ones.

### 5. A STUDY OF DETECTED CASES

The responsibility for the proper support in the longwall is assigned mainly to the energy-mechanical dispatchers who diagnose the current state of the support of the operation of the hydraulic props.

The most common faults found are listed below.

#### 5.1. Loss of data transmission

After generating the chart on 2.09.2021 an unusual course of the pressure diagram in the monitoring systems of the powered support section was noticed. The graph (Fig. 10) shows the data transfer dropouts which is visually generated as a graph of sudden pressure drop and pressure increase. The visible defect is damage to the cable connecting the computer to the sensor, which resulted in a loss of transmission. The defect was repaired on 2.11.2021 at around 6:00 p.m. and from that moment the picture of the chart changes (Fig. 10). The powered support section in the period from 2.12.2021 to 2.16.2021 was incorrectly expanded.

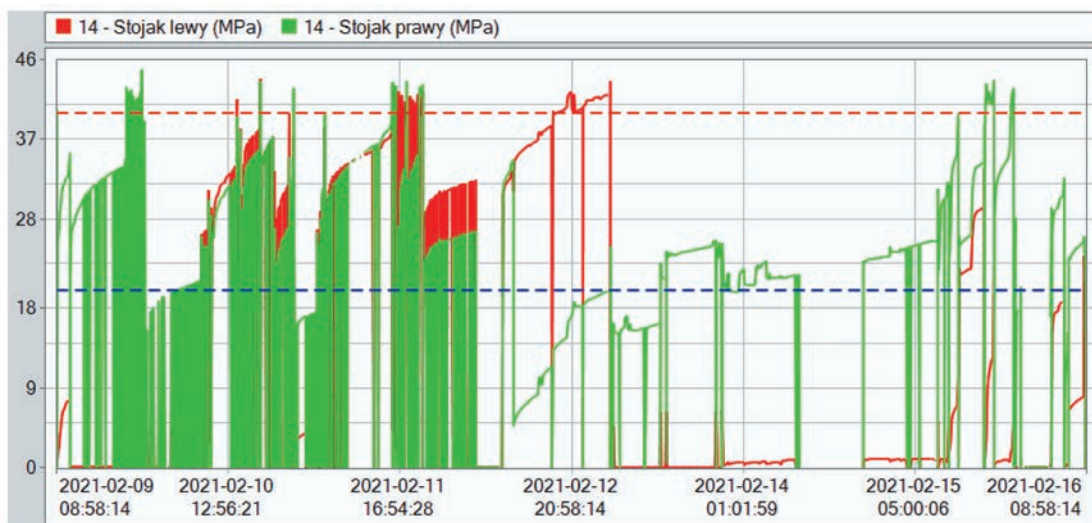

Fig. 10. Graph of data transmission loss



## 5.2. Failure of the sensor of one of the section props

One of the section props (Fig. 11) of the powered support has a low condition. During the expansion of both props, pressure jumps are visible, for one stand the value of the initial load capacity is achievable, and for the other there is only a small increase in pressure in the diagram and constant stabilization at zero values. The energy-mechanical dispatch-

er stated that the defect was most likely a failure of the prop sensor.

## 5.3. Damage to the prop of the powered support section

The course of the graph (Fig. 10) for the expansion of the powered support section for one prop is correct with the natural increase resulting from the convergence of the excavation, while for the other it may indicate a leak in the prop's hydraulics.

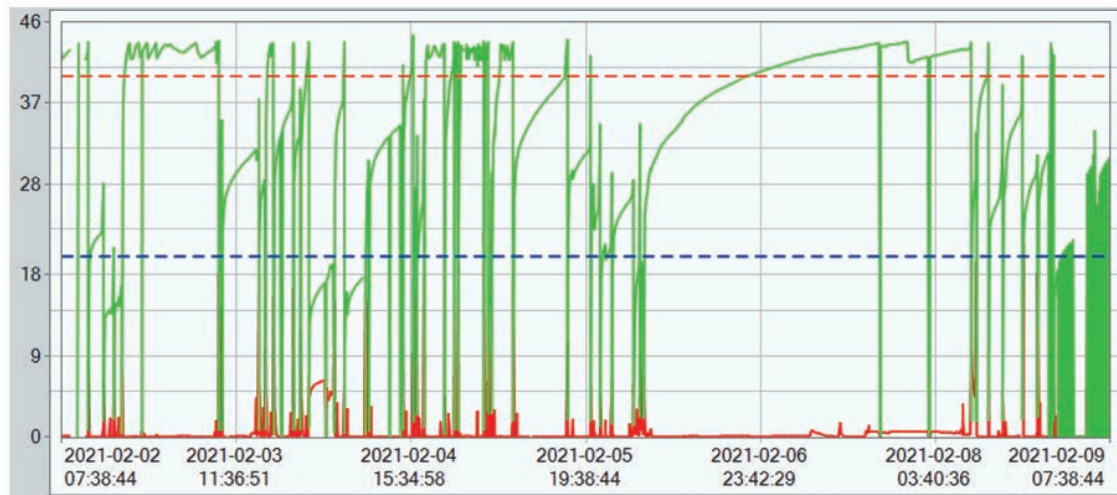

Fig. 11. Prop sensor failure chart

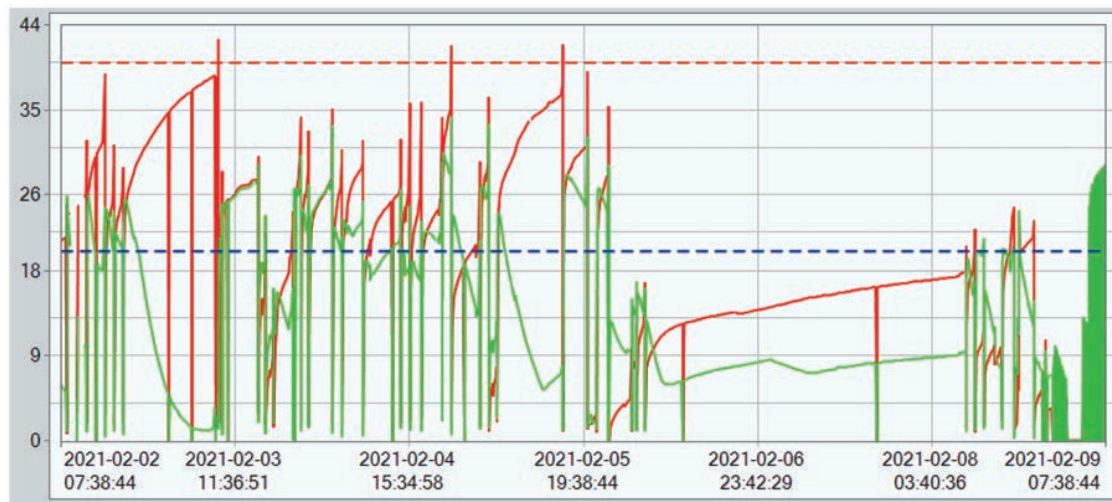

Fig. 12. Chart showing leakage in the prop

## 6. DETERMINATION OF HYSTERESIS IN MONITORING SYSTEMS FOR POWERED SUPPORT SECTIONS

In hard coal mining longwalls, the load bearing capacity of the ceiling is a key element of securing of

the longwall excavation against the fall of roof rocks. The hysteresis of the course (Fig. 13) is the dependence of the current state of the system of the elastic medium, which is the rock mass, to the change from the preceding state from the moment of its initial load bearing task, the hysteresis can be called the delay of the elastic medium reaction.

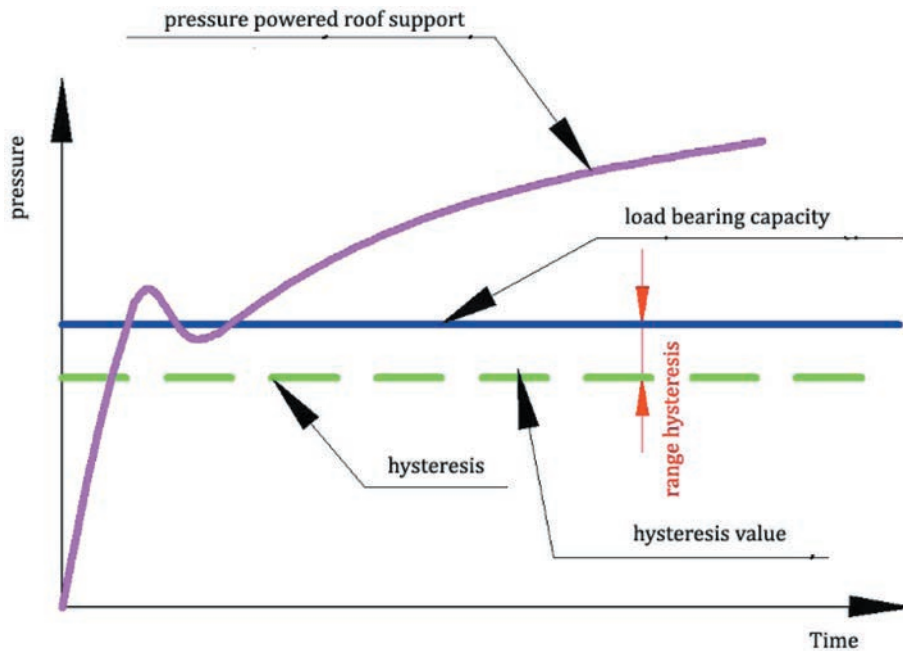

Fig. 13. Determination of hysteresis

For the proper functioning of the systems, it has been noticed that the reaction of a properly built-up section to the adjacent sections of the powered support may result in incorrect information being provided to the user (miner – builder) operating the longwall. A section after proper installation (Fig. 13), i.e. obtaining initial load capacity in the limit values, the value of which is within the range of the minimum decline, relaxation or activation of the adjacent section, may start to show a false result. Therefore, after obtaining the value of the initial load capacity depending on the geological and mining conditions in the longwall, we determined the pressure drop hysteresis of up to 5% of the initial load capacity, which in Figure 13 is shown as the hysteresis range between the blue and green lines of the diagram.

The programmed drop in hysteresis is necessary for the employee responsible for the mine resistance monitoring systems.

## 7. THE IMPACT OF SUPPORT SYSTEMS OF A POWERED SUPPORT SECTION ON ROCK MASS TREMORS

Mining with a breaking down longwall causes subsidence of the torn rock layers that are located above the mining excavation. This results in the breaking of sandstone rock layers, which, after exceeding their limit span, lose their bearing capacity and break into

blocks. Processes of this type occurring in the shaking layers trigger dynamic phenomena in the rock mass.

One of the elements noticeable during the analysis of the support capacity of the support sections in the breaking down longwall were rock mass tremors. The rock mass tremors were visible during the monitoring of the powered support sections, which, visualized on 2D charts, were characterized by a sudden minimal increase in pressure and an immediate drop in support. The changes illustrated by the system were visible on the cross-section of the entire wall and related to one moment. The following is a 3D diagram of wall 922 from May 22, 2020 (Figs. 14–16), in which the rock mass trembled in the area of the wall described. The shock was visualized at the place of its detection, and the shock energy value was  $5 \cdot 10^5$  J. The site of the shock was visualized in the system as a pressure drop starting in the area of section 103. The spread was towards the front and back of the wall.

When analyzing the precise course of the support capacity during the shock, a minimal increase in the support capacity was noticeable (Fig. 16) together with its sudden decrease. The anomaly that resulted from the shock affected the sections in the region of the shock.

We are confident that the support monitoring system could serve as a support system for mining geophysics stations in helping to locate rock mass tremors.

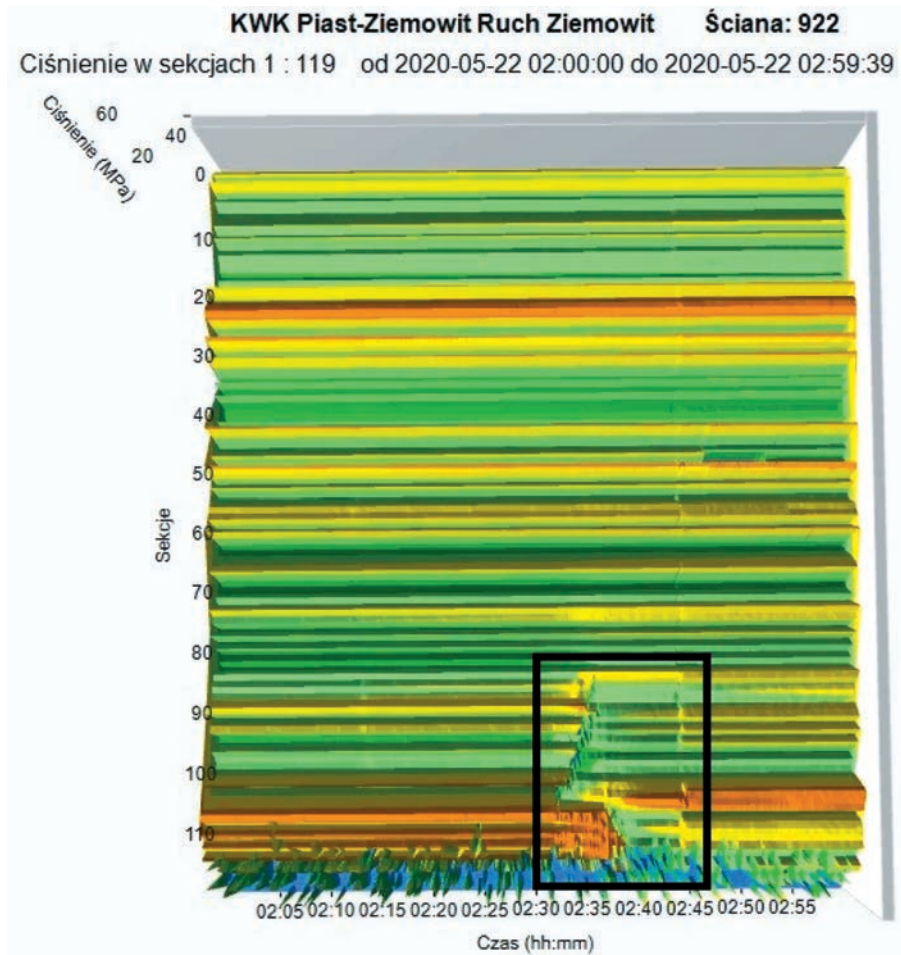

Fig. 14. 3D diagram showing the rock tremor

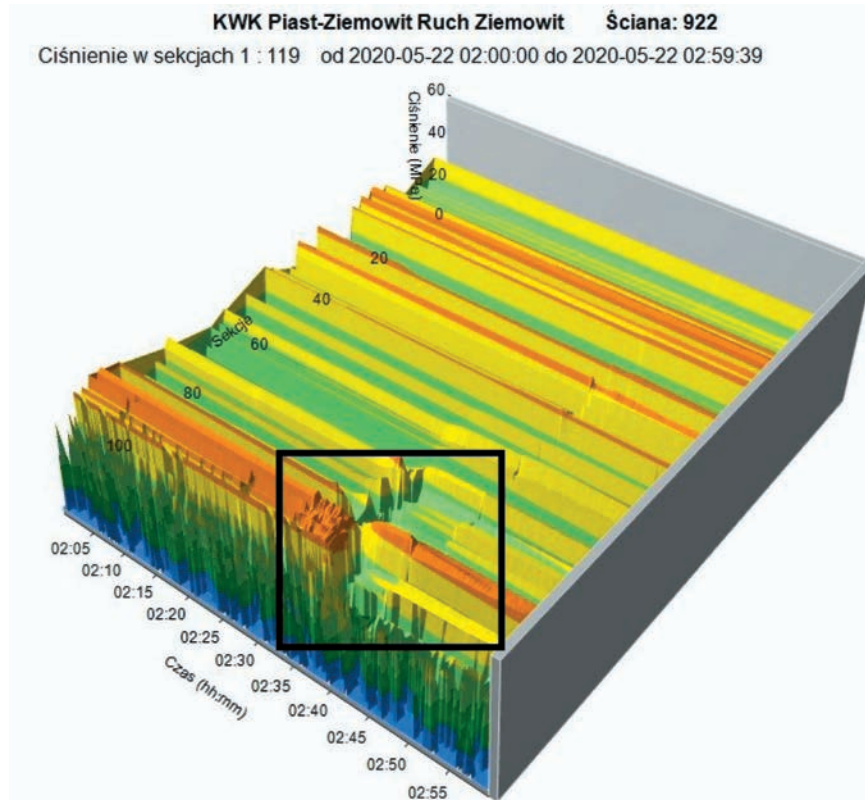

Fig. 15. Side view of the 3D plot of wall 922 – location of the shock



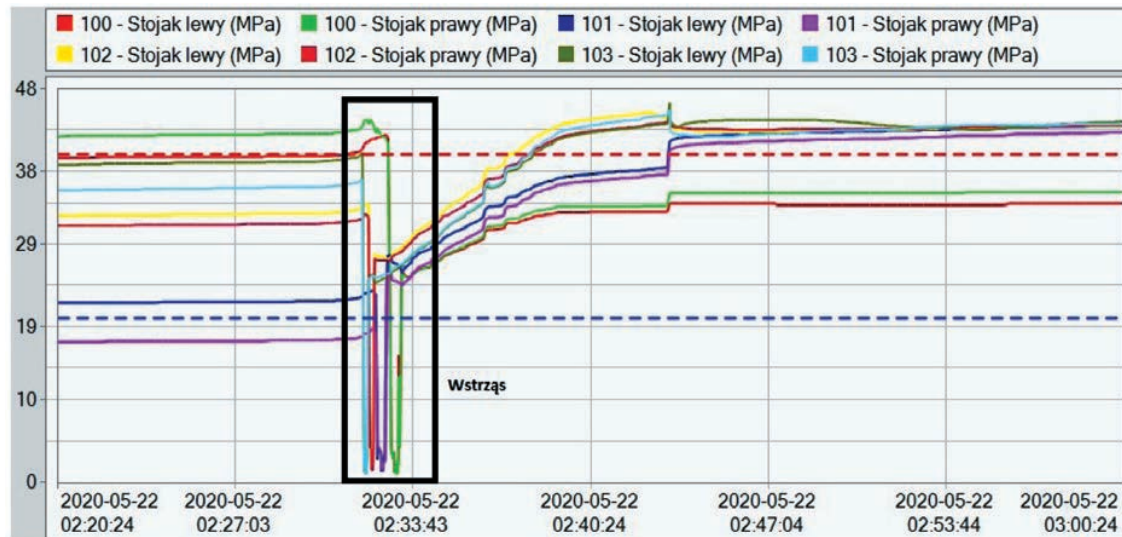

Fig. 16. Line chart of sections 100 to 103 of longwall 922 – location of the shock

## 8. CONCLUSIONS

- The selection of the correct support for the support section is essential to ensure the stability of the excavation and the appropriate level of safety for the crew working on the longwall.
- The monitoring system of the powered support section allows the diagnosis of the condition of the hydraulic props from the mine surface, where the initial faults are often not visible to the user working underground in the mine.
- Downfall rocks and deepening failures of the hydraulic props of the powered support section cause the work continuity to be interrupted, while continuous, proper control by the monitoring systems of the powered support section may reduce the costs associated with production break of the longwall.
- The active support system used in the Ziemowit mine allows for continuous contact of the powered support section with the rock mass, which ensures the proper support immediately after the advance of support.
- The passive support system causes losses during the work of the operator (miner-builder), who spends more time on the correct support of the ceiling during installation. An active monitoring system supports the operator's work and supplies the section with the correct support.
- The system is generally available to employees working in the longwall by installing a computer with the requisite software in the vicinity of the longwall.
- Monitoring information is saved in a database, which an operator can return to at any time and analyze the cause of a fault or a leak.
- Programming hysteresis into the support monitoring system is the basis for ensuring proper operations for the operating worker (miner-builder), the traffic light installed on the powered support section does not mislead them with a minimum pressure drop.
- The system can be used by mining geophysics stations as an additional tool to locate the occurrence of rock mass tremors. There is a connection between the monitoring of longwall bearing capacity and the detection of rock mass tremors.
- In longwalls with an active support system for the powered support section, we have completely eliminated production breaks caused by falling roof rocks. Active support immediately supports the ceiling and does not lead to the delamination of the direct ceiling, which results in continuous extraction.
- In longwalls that use a passive support system, we noticed a greater tendency to incorrectly support the ceiling during the operation of the wall.
- The development of the system illustrates the geometries of the construction of powered support sections, showing the deflections of the powered support sections.

Based on the experience of the mine, we were able to assess the effectiveness of the monitoring system for the powered support section. Certainly, the system will be widely used in hard coal mines, in particu-

lar in the Piast-Ziemowit Mine, which is convinced of the effectiveness of this system.

#### References

- [1] Prusek S.: *Stateczność wyrobisk ścianowych podczas eksploatacji pokładów węgla kamiennego z zawalem skał stropowych*. Główny Instytut Górnictwa, Katowice 2016.
- [2] Rajwa S.: *Główne przyczyny utraty stateczności wyrobiska ścianowego*. *Bezpieczeństwo Pracy i Ochrona Środowiska w Górnictwie* 2017, 3: 3–12.
- [3] Elsta Elektronika sp. z o.o. S.K.A – Katalog produktu.
- [4] Płonka M., Rajwa S., Lubosik Z.: *Ocena pracy obudowy zmechanizowanej na podstawie danych z monitoringu ciśnień i postępu sekcji*. *Przegląd Górniczy* 2017, 4(73): 25–33.

*Krzysztof KRASUCKI, M.Sc., Eng.*

*Tomasz KUDŁACIK, M.Sc., Eng.*

*Krzysztof AUGUSTYNIAK, M.Sc., Eng.*

*Polska Grupa Górnicza S.A.*

*Oddział KWK Piast-Ziemowit Ruch Ziemowit*

*ul. Granitowa 16, 43-155 Bieruń, Poland*

*k.augustyniak@pgg.pl*