



Received 06.02.2020
Reviewed 30.04.2020
Accepted 20.07.2020

Hydrodynamic features of the floating water outlet from a pumping station

Ievgenii GERASIMOV^{id}, Henrikh HERASYMOV^{id}, Oleg PINCHUK^{id} ✉

National University of Water and Environmental Engineering, 11 Soborna St., 33028 Rivne, Ukraine

For citation: Gerasimov I., Herasymov H., Pinchuk O. 2021. Hydrodynamic features of the floating water outlet from a pumping station. *Journal of Water and Land Development*. No. 48 (I–III) p. 162–171. DOI 10.24425/jwld.2021.136159.

Abstract

The article considers issues of ensuring sustainable agricultural production by increasing reliability of an irrigation system and water security. The article describes results of hydraulic tests performed at the water outlet with a vertical movement valve member.

Resistance coefficients and hydrodynamic effects at the water outlet were determined experimentally. The study developed a method for calculating hydromechanical transient processes in the water outlet at the stop and start of the pump.

The paper substantiates the new construction of a water outlet facility with a vertical displacement of the breakdown valve. Such a design better corresponds to peculiarities of the operation of pumping stations and, if there are water pipes of considerable diameter, it has a positive effect on transition hydrodynamic processes by reducing the number of failures and downtime by up to 10%.

Key words: *hydromechanical transient processes, pumping station, resistance coefficient, water outlet*

INTRODUCTION

According to the definition of the UN-Water: water security is “The capacity of a population to safeguard sustainable access to adequate quantities of acceptable quality water for sustaining livelihoods, human well-being, and socio-economic development, for ensuring protection against water-borne pollution and water-related disasters, and for preserving ecosystems in a climate of peace and political stability”. One of the important directions of the implementation of water security is to ensure sufficient water reserves for the production of food and energy. Thus, the issue of ensuring sustainable agricultural production consists of two interrelated tasks: reducing risks for the agricultural production by increasing the reliability of the irrigation system, and fostering the rational use of water resources by defining parameters of the water management system.

The improvement of the design, construction and operation of pumping stations and culverting facilities is necessary in the water engineering development programme. One of favourable directions for enhanced energy efficiency and reliability of pumping stations is the improvement of water drainage facilities, and, in particular, water outlet facilities in large pumping stations [VALIPOUR 2017].

At present, siphon type water outlets are the most popular. In case pumps stop operating, to prevent the reverse flow of water through these facilities, they are equipped with different types of vacuum breakdown valves. The peculiarities of the water outlet operation are connected with transient hydraulic and mechanical processes at pump start-up and shut-down. In pumping stations with large axial and centrifugal pumps, water discharge through a stopping pump is a radical way of combating the water hammer effect. In these cases, the major task is to prevent the flow of water from the elevated reservoir into the drainage pipeline. In siphon water outlets, it is performed by the vacuum breakdown valves of various designs, e.g. hydraulic, hydromechanical and electromechanical [KARELIN, NOVODEREZHNIKIN 1980; CHEBAYEVSKIY *et al.* 1982].

The main disadvantage of siphon water outlets is the limited fluctuation of water levels in the discharge channel with the use of hydraulic vacuum breakdown valves. In order to overcome this shortcoming, we suggest to use the proposed self-propelled floating water outlet with a hollow valve member [HERASYMOV, BURDIUZZHA 1981].

The research objectives are as follows: (1) to carry out hydraulic tests of water outlet facilities with a vertical movement of a valve member; (2) to experimentally determine resistance coefficients and hydrodynamic effects

on the water outlet; (3) to develop a method for calculating hydromechanical transient processes in the water outlet at the shut-down and start-up of the pump; (4) to evaluate the efficiency of water outlet operation.

Currently used types of water outlets have a number of disadvantages. Even the most common siphon water outlets have certain shortcomings. Major drawbacks of siphon water outlets include: the need for high leak resistance, significant metal content, comparatively large head losses, the need to install a vacuum breakdown valve, rigid requirements for water level fluctuations in the elevated reservoir (outlet channel), complications with siphon charging, and increased hydrodynamic loads on the equipment at the start of the pump with the empty pipeline, which is accompanied by air coming out from under the crown of the inclined siphon line in large volumes – the so-called “gurgling drains” etc.

In this paper, we substantiated a new construction of a water outlet facility with a vertical displacement of the breakdown valve. Such a design better reflects peculiarities of pumping station operation and, if there are water pipes of considerable diameter, it has positive effects on the transition hydrodynamic processes.

There is a need to adopt the following provisions as a working hypothesis.

In order to meet the requirements for irrigation pumping units, the water outlet should have the following properties: high conveying capacity in operational modes, no need for lifting mechanisms, simplicity of design and low material capacity, as well as high reliability of work in transition hydromechanical processes.

In order to provide the first characteristics, it is necessary to obtain the perfect shape of the flowing part and low speed at the outlet. The second characteristics will be provided, if one uses the energy of water passing through the outlet for lifting and lowering of the breakdown element of the water outlet. The need to fulfil the third and fourth requirement prompts to abandon the usual siphon design of the outlet and use the construction with a vertical movement of breakdown valves. In the latter case, the supply and removal of air from the pipeline may be carried out using simple air pipes. This has a positive effect on the transient processes in the pump station. One can use cone-shaped hollow valves or thin-walled rotating objects that

have sufficient strength despite peripheral or central displacement constraints.

MATERIAL AND METHODS

Existing dependencies for the determination of conveying capacity and hydrodynamic characteristics of water outlet facilities are the result of studies on structures presented in reference materials (IDELCHIK [1954; 1975], BASHTA *et al.* [1970], SLISSKII [1970], BOGOMOLOV, MIKHAILOV [1972], ALTSHUL, KISELEV [1975], CHUGAYEV [1975], VIL'NER *et al.* [1976], BOL'SHAKOV (ed.) [1977], KURGANOV, FEDOROV [1978], STEPANOV *et al.* [1984], YUREV [2001], JONES *et al.* (eds.) [2008], KAY [2008]), and in the specialist literature (GAVRILENKO *et al.* [1968], PLESEVIČIUS [1974], SLISSKII [1974], TSUKANOVA *et al.* [1975], MIKHAILOV, ZOLOTUKHIN [1977], MIKHAILOV, ZOLOTUKHIN [1978]; ANDRIASHEV [1979], NOVAK *et al.* [2007], and SHOMAYRAMOV *et al.* [2019]).

Let us consider the general framework that helps to determine the conveying capacity of water outlet facilities in simplified, ideal conditions, when the diameter of the valve saddle is equal to the diameter of the pipeline, that is $D_c = D_0$. If we take into account the work of the water outlet facility in the short pipeline [CHUGAEV 1975], then the structural design for the water flow from the pipeline to the reservoir will look as in Figure 1a.

We use the Bernoulli equation with respect to plane 0–0 for section 1–1 at the place of a piezometer installation and for section 2–2 by the level of water in the reservoir:

$$z_1 + \frac{p_1}{\rho g} + \frac{\alpha v_1^2}{2g} = z_2 + \frac{p_2}{\rho g} + \frac{\alpha v_2^2}{2g} + h_l \quad (1)$$

Where: z_1 and z_2 = the exceedance of calculated cross sections over plane 0–0; p_1 and p_2 = the pressure in sections 1–1 and 2–2; v_1 = the average velocity in the pipeline in section 0–0; v_2 = the average velocity in section 2–2; α = Coriolis coefficient, $\alpha \approx 1$; ρ = water density; g = the acceleration of gravity; h_l = the total hydraulic loss in the water output facility.

The total loss consist of friction loss along the length of the pipeline h_{lp} , loss in an angle pipe h_{la} , loss in the annular in the gap h_{lg} , and the loss at the output h_{lo} .

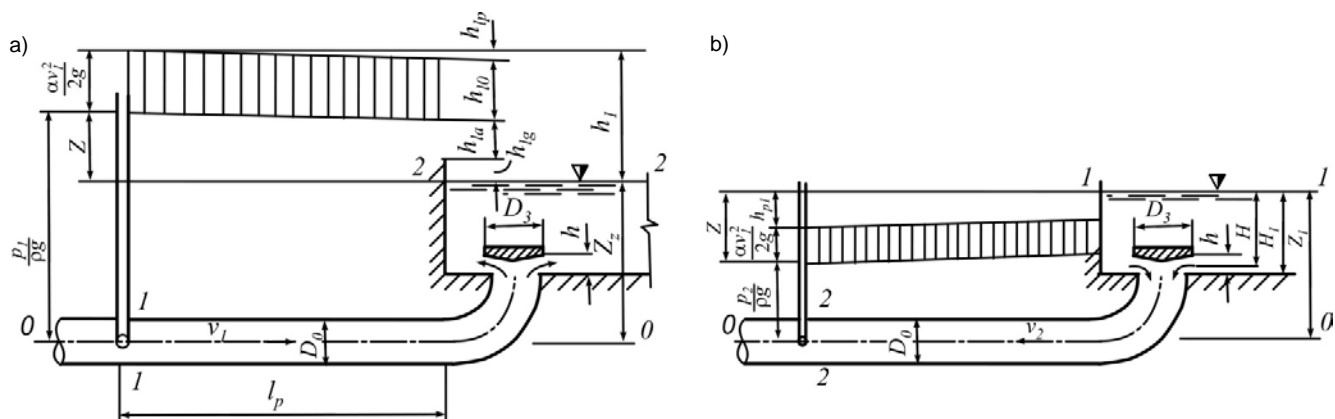

Fig. 1. Structural design of water outlet: a) in short pipeline when water is supplied to reservoir (direct water flow), b) at outflow of water from reservoir (reverse water flow); source: own elaboration

$$h_l = h_{lp} + h_{la} + h_{lg} + h_{lo} \quad (2)$$

The center of section 1–1 coincides with comparison plane 0–0, so $z_1 = 0$. Excess pressure on the surface of the reservoir is absent, hence $p_2/\rho g = 0$. With a large area of the reservoir mirror, the water velocity in the reservoir may be neglected; thus, we assume $v_2 = 0$.

In these conditions, the Equation (1) will be simpler, i.e.

$$\frac{p_1}{\rho g} + \frac{\alpha v_1^2}{2g} = z_2 + h_l \quad (3)$$

At the same time, for geometric reasons

$$\frac{p_1}{\rho g} = z_2 + z \quad (4)$$

Where z is the difference in water levels in the piezometer and the reservoir. Then

$$z + \frac{v_1^2}{2g} = h_l \quad (5)$$

Let us show losses on the water outlet according to the generally accepted methodology:

$$h_l = \zeta_{w0} \frac{v_1^2}{2g} \quad (6)$$

Where ζ_{w0} is the resistance coefficient of the water outlet facility, which takes into account all kinds of losses, including the output loss.

By substituting (6) in Equation (5), we obtain

$$z + \frac{v_1^2}{2g} = \zeta_{w0} \frac{v_1^2}{2g} \quad (7)$$

After dividing both parts of the equation by velocity head $v_1^2/2g$, we get:

$$\frac{z}{v_1^2/2g} + 1 = \zeta_{w0} \quad (8)$$

or

$$\zeta_{w0} = 1 + \zeta \quad (9)$$

Where the coefficient of water outlet resistance ζ corresponds to the following dependence:

$$\zeta = \frac{z}{v_1^2/2g} \quad (10)$$

and is based on experimental data.

If there are no back pressure valves on the pressure pipeline, water flow direction in the pipeline will change after the pump is switched off. For a short period, water flows out of the reservoir into a pressure pipeline through the closing water outlet. At the beginning, the flow fills the pressure pipeline, then the continuity of the flow is reduced as the flow throttling at the water outlet by the valve member increases. At the same time, the emptying of the pipeline through the pump increases. In this period, insufficient water volume in the pipeline is supplemented by the flow of air through the air pipe. The leakage of water underneath the valve member into the pipeline in case of flow failure will occur through the bottom hole. Figure 1b demonstrates the considered water outlet design.

While formulating the Bernoulli equation for sections 1–1 and 2–2 with flooded leakage (Fig. 1b), in a similar way to the previous case, we obtain the following relations:

$$\zeta_{w01} = \zeta_1 - 1 \quad (11)$$

$$\zeta_1 = \frac{z}{v_2^2/2g} \quad (12)$$

Where: ζ_{w01} = a coefficient which characterizes all losses in the water outlet during the reverse flow of water; v_2 = an average reverse water velocity in the pipeline; z = the level difference between the reservoir and the piezometer.

Figure 2a presents the well-known dependences of coefficients ζ_{w0} and ζ_{w01} and the relative opening of the valve member h/D_0 , having in mind that h is the opening of the gate and D_0 is the diameter of the pipeline.

Figure 2b shows dependency diagrams.

$\zeta_{w0} = f(h/D_0)$ for direct water flow from the pipeline to the reservoir for several types of devices with the following analytical or tabular presentation:

a) conical valve – the Bach equation [IDELCHIK 1954; 1975; KURGANOV, FEDOROV 1978] at:
 $0.125 < h/D_0 < 0.4$

$$\zeta_{w0} = 0.6 + 0.15 \left(\frac{h}{D_0}\right)^{-2} \quad (13)$$

b) conical safety valve [KONDRATIEVA 1976]

h/D_0	0.05	0.10	0.15	0.2	0.3	0.4	0.5	0.6
ζ_{w0}	43.0	12.5	6.5	4.5	3.5	3.0	3.0	3.0

c) automatic cylindrical shutter [KOVALENKO, TUGAI 1974] at:

$0.05 < h/D_0 < 0.25$

$$\zeta_{w0} = 1.5 \left(\frac{h}{D_0}\right)^{0.726} \quad (14)$$

d) plated valve without lower guides [IDELCHIK 1954; 1975; KURGANOV, FEDOROV 1978]:

$0.1 < h/D_0 < 0.25$

$$\zeta_{w0} = 0.55 + 4 \left(\frac{b}{D_0} - 0.1\right) + 0.155 \left(\frac{h}{D_0}\right)^{-2} \quad (15)$$

e) straight exhaust shafts that have circular cross-section with a flat screen [IDELCHIK 1954; 1975]. The equation from SLISSKII [1974] perfectly corresponds to these data.

$$\zeta_{w0} = 0.92 + 0.07 \left(\frac{h}{D_0}\right)^{-2.6} \quad (16)$$

f) pipeline valves in marine systems [PLESEVIČIUS 1974]

$$\zeta_{w0} = \zeta_0 \left[0.67 + 0.077 \left(\frac{h}{D_0}\right)^{-1.415}\right] \quad (17)$$

Where ζ_0 is accepted at $h/D_0 = 0.3$;

g) ball valve [IDELCHIK 1975; KURGANOV, FEDOROV 1978] at $0.1 < h/D_0 < 0.25$

$$\zeta_{w0} = 2.65 - 0.8 \left(\frac{h}{D_0}\right)^{-1} + 0.4 \left(\frac{h}{D_0}\right)^{-2} \quad (18)$$

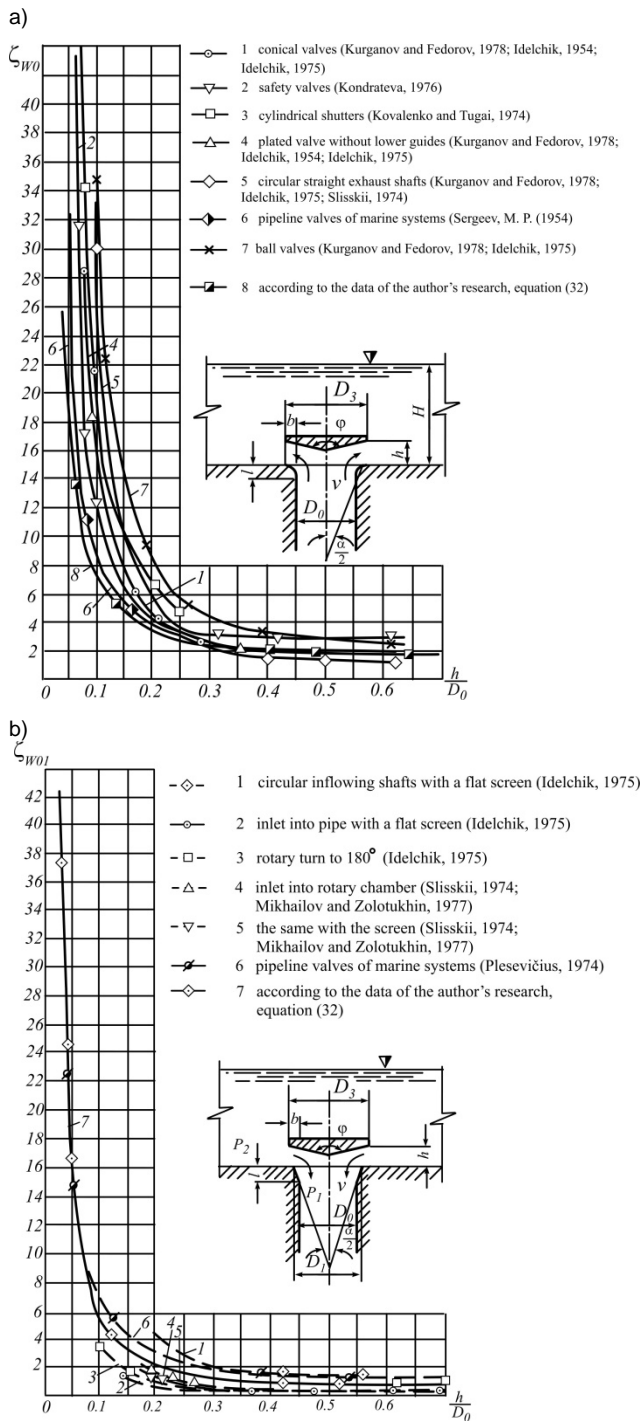

Fig. 2. Dependency diagrams: a) $\zeta_w = f(h/D_0)$ for direct flow of water, b) $\zeta_{w01} = f(h/D_0)$ of various devices in reverse water flow; source: own elaboration

h) conical valve with a conical bottom surface at an angle of tapering equal to 90° [VILNER *et al.* 1976; YUREV 2001]

h/D_0	0.10	0.15	0.20	0.25	0.30	0.35	0.40
ζ_{w0}	15.6	7.27	4.35	3.00	2.27	1.82	1.54

i) conical valve with a flat bottom surface at an angle of tapering equal to 90° [VILNER 1976]

h/D_0	0.10	0.12	0.14	0.16	0.18	0.22	0.25
ζ_{w0}	8.70	5.77	4.24	3.16	2.58	1.97	1.74

Figure 2b shows dependency diagrams $\zeta_{w01} = f(h/D_0)$ in the case of a reverse flow of water in the pipeline from the reservoir to the following devices:

a) straight inflowing shafts of circular cross-sections with a flat screen [IDELCHIK 1975]

h/D_0	0.2	0.3	0.4	0.5	0.6	0.7	0.8	0.9	1.0
ζ_{w01}	4.40	2.15	1.78	1.58	1.35	1.23	1.13	1.10	1.06

b) pipe inlet has a flat screen before the inlet [BOLSHAKOV *et al.* 1977; IDELCHIK 1975], Idelchik's equation:

$$\zeta_{w01} = \zeta_{w0} + \sigma_s \left(\frac{D_0}{D_1}\right)^4 \quad (19)$$

In case of $l/D_0 = 0.16$; $D_0/D_1 = 0.8$; $\alpha = 64^\circ$, there is the following expression

$$\zeta_{w01} = 0.16 + 0.41\sigma_s \quad (20)$$

h/D_0	0.2	0.3	0.4	0.5	0.6	0.8	1.0
σ_s	1.65	0.68	0.40	0.24	0.14	0.03	0
ζ_{w0}	0.84	0.44	0.32	0.26	0.22	0.17	0.16

c) spatial rotary 180° valve (for suction) [IDELCHIK 1975]

h/D_0	0.1	0.2	0.3	0.4	0.5	0.6	0.7	0.8
ζ_{w01}	3.45	1.0	0.6	0.5	0.5	0.7	1.2	1.37

d) inlet to a circular inlet chamber with a flat screen (model 1) [PLESEVIČIUS 1974]

h/D_0	0.2	0.3	0.4	0.5	0.6	0.7	0.8	0.9	1.0
ζ_{w01}	1.50	0.95	0.71	0.62	0.57	0.54	0.52	0.50	0.50

e) pipeline valves in marine systems [PLESEVIČIUS 1974].

$$\zeta_{w0} = \zeta_0 \left[0.625 + 0.0618 \left(\frac{h}{D_0}\right)^{-1.635} \right] \quad (21)$$

Where ζ_0 is taken at $h/D_0 = 0.3$.

For real devices, the condition $D_3 = D_0$ is not always met. For example, for safety valves $D_3 < D_0$, and as a rule for water outlets $D_3 > D_0$. Calculations must take into account these conditions.

In case of a direct flow of water from the pipeline to the reservoir, there is a hydrodynamic lifting effect on the valve member at the water outlet, which can be determined by the following dependence

$$F = \Delta p \left(\frac{\pi D_0^2}{4}\right) \beta \quad (22)$$

Where: D_0 = the diameter of the pipeline at the section close to the water outlet; $\Delta p = p_1 - p_2$ is the pressure drop at water outlets; β = the flow pressure coefficient.

The value of the flow action on the valve member varies during its opening, and it is taken into account by the dependence of the pressure coefficient β and the value of relative opening h/D_0 .

The value of the flow action on the valve member varies during its opening, and it is taken into account by the dependence of the pressure coefficient β and the value of relative opening h/D_0 .

Relevant reference data are quite limited:

a) according to KONDRATIEVA [1976] as a result of testing safety valves at $D_3/D_0 = 1.25$, we obtain the following values:

h/D_0	0.05	0.1	0.2	0.3	0.4
β	0.94	0.917	0.908	0.900	0.870

b) according to BOGOMOLOV and MIKHAILOV [1972] and GAVRILENKO *et al.* [1968], based on the reaction, the effect of a flow on a damper or a screen can be represented as:

$$F = \Delta p \left(\frac{\pi D_0^2}{4} \right) + Q \rho v \quad (23)$$

Where: Q = liquid (fluid) loss; v = fluid velocity in the inlet pipeline; ρ = liquid density.

After a series of transformations, taking into account dependences (6) and (9), we obtain the following equation:

$$\beta = 1 + \frac{2}{\zeta} \quad (24)$$

Then, for the pipeline valves in marine systems [PLESEVIČIUS 1974], we obtain:

h/D_0	0.04	0.06	0.1	0.2	0.3	0.4	0.5	0.6	0.7
β	1.087	1.136	1.261	1.685	2.16	2.46	2.69	2.89	3.0

Thus, different sources recommend different values of the pressure coefficient β .

During the reverse flow from the reservoir to the pipeline, there is a hydrodynamic suction force which tries to press the valve member to the saddle. The lowering of the valve member on the saddle under certain conditions can produce a hammer effect. We are aware of only one paper [PEPLOV, KOKAYA 1956] that is devoted to the experimental study of the suction force phenomenon observed during the flow around repair and emergency closing valves with air chambers. The results of these studies have shown that the value of the suction force can be determined by the following dependence:

$$F_n = 0.5 \rho v_3^2 f_3 \quad (25)$$

Where v_3 = water velocity in a slotted ring outlet of height h ; f_3 = the outlet area within the sealing belt of diameter D_3 .

We accept the dependence for determining the suction force by analogy with the lifting force as follows:

$$F_n = \Delta p \left(\frac{\pi D_0^2}{4} \right) \beta_n \quad (26)$$

Where: $\Delta p = p_1 - p_2$ is differential pressure across the valve, β_n = the coefficient of suction power.

By equating the right-hand sides of expressions (25) and (26), performing corresponding transformations, and taking into account (11) and (12), we obtain the following equation:

$$\beta_n = \frac{1}{16 \zeta_{w01} \left(\frac{h}{D_0} \right)^2} \quad (27)$$

Using data [IDELCHIK 1975; PLESEVIČIUS 1974], based on the value of ζ_{w01} , we find the value of β_n :

h/D_0	0.04	0.06	0.08	0.1	0.15	0.2	0.3	0.4	0.5
ζ_{w01}	26.1	14.54	9.92	7.58	4.98	3.96	3.14	3.0	3.0
β_n	2.33	1.86	1.53	1.28	0.87	0.615	0.344	0.202	0.125

It should be noted that with a decrease in the relative opening of the shutter, the value of β_n is continuously increasing, which is the reason for the possible hammer closure of the shutter before it rests on the saddle. At the same time, for a closed shutter, the suction force should be equal to one, that is $\beta_n = 1$. Consequently, at the point which corresponds to the zero opening of the shutter $h/D_0 = 0$, the function $\beta_n = f(h/D_0)$ has a continuity gap.

Experimental study of the floating water outlet. The purpose of laboratory studies is to obtain coefficients of hydraulic resistance at water outlets and pressure coefficients under different operating conditions. In order to experimentally determine these values in a laboratory setup with a model of water outlet, it is necessary to perform measurements of the following parameters:

- 1) water volume passing through water outlet in direct and reverse water flow;
- 2) loss of pressure in the same regimes;
- 3) hydrodynamic action of the flow on the valve member in the same modes; and
- 4) value of the opening of the valve member.

For these measurements, we use two dimensional triangular weirs, piezometers, DOSM-3-0.06 dynamometer and level gauges (Spitzentaster).

Figure 3 shows the design of the laboratory setup. The setup is located in the inter-departmental laboratory of the State Agrarian University of Moldova (SAUM).

Models of the water outlet facility were investigated in a hydraulic of 65 cm wide and 350 cm long tray with glass sidewalls. The research methodology involves using the method of physical model simulation. The modelling of hydromechanical phenomena is carried out on the basis of the similarity and dimensions theory [BOGOMOLOV, MIKHAILOV 1972; CHUGAYEV 1975]. Hydraulic modelling allows us to determine the hydraulic mode of the building, investigate the phenomena that are not subject to a theoretical calculation, find ways to eliminate adverse factors and phenomena, and to choose the best possible solutions.

Similar phenomena are known to occur in geometricaly similar systems, when scholars observe processes of the same physical nature, and the same values at similar points have constant relations between them. When conducting hydraulic studies, researchers use the following dimensionless criteria (numbers) of similarity: Froude number; Reynolds number, and Euler number.

Thus, in such flows, the ratios of inertial forces to individual operating forces have the same numerical values. An important consequence of the flows' similarity is the uniformity of dimensionless coefficients for the model and field values, for example resistance coefficients $\zeta = idem$, loss factors $\mu = idem$ etc. In the future, we plan to process experimental data for one or the other dimensionless coefficients and this will immediately allow us to determine dependences for field dimensions of the premises.

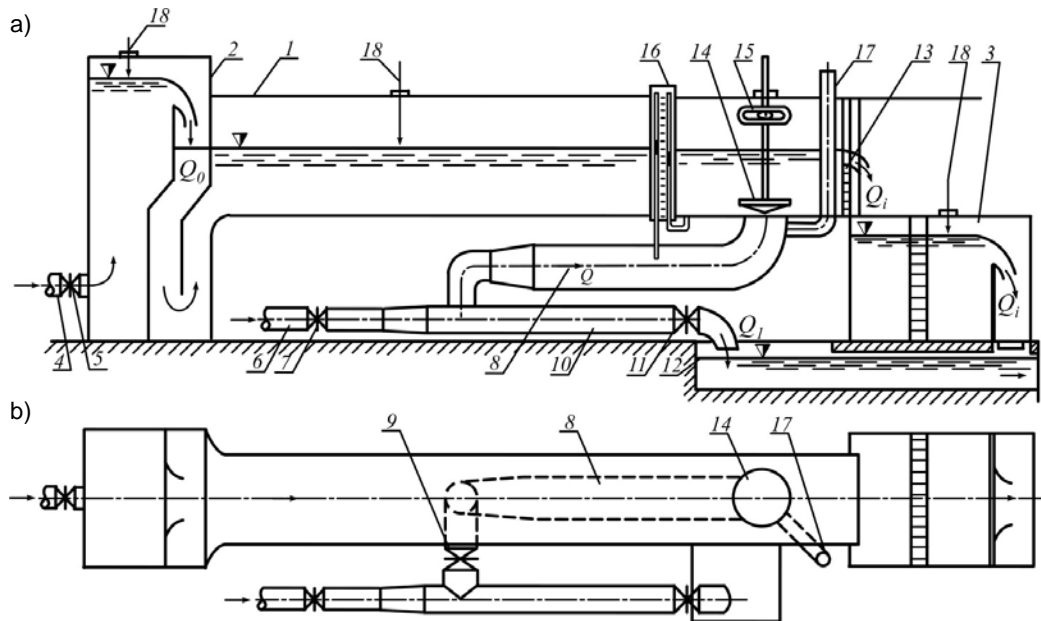

Fig. 3. Design of laboratory setup: 1 = hydraulic tray; 2 = measuring tank at the inlet of the tray with triangular weir to measure the total loss Q_0 ; 3 = measuring tank at the outlet with triangular weir to measure the loss, which is dumped from the tray Q_i ; 4 = pipeline which feeds the pressure measuring tank no. 2; 5 = valve on the feed pipeline; 6 = pressure pipeline; 7 = valve on a pressure pipeline; 8 = pressure pipeline of the water outlet; 9 = valve of the pressure pipeline of the water outlet; 10 = drainage pipeline; 11 = valve on the drainage pipeline; 12 = concrete drain tray; 13 = to adjust the water level in the tray; 14 = valve member of water outlet; 15 = DOSM-3-0.06 dynamometer; 16 = piezometers of the floating water outlet; 17 = air intake pipe for water outlet; 18 = level gauge (Spitzentaster); source: own elaboration

For a complete dynamic similarity, the study requires simultaneous equality of similarity criteria $Fr = idem$ and $Re = idem$. This is practically difficult to perform, because it requires modelling on a liquid which viscosity is very different from the viscosity of water. Therefore, scholars use partial simulation while defining the criterion.

In the study of water outlets, we shall accept the Froude number as a determining criterion. Moreover, for the main operational modes of the structures, one should observe the self-similarity according to Reynolds, when the flow regime depends on this number.

The determination of hydraulic flow parameters in water outlets was carried out in established water motion modes. In terms of hydraulic resistance, direct motion meets the conditions for the flow discharge from the pipeline to the reservoir under a specific water level, when valves 7 and 9 are open and gates 5 and 11 are closed (see Fig. 3). At the same time, the reverse motion corresponds to conditions at the water inlet to the pipeline, when gates 5 and 11 are open the gates 7 and 9 are closed.

The measurement of the flow through the water discharge in the direct motion of water is carried out by means of a projected dimensional triangular water outlet located within tank 3. In the reverse flow of water, the flow through the water outlet is defined as the difference in losses, which is measured at two water outlets in tanks 2 and 3, that is,

$$Q_1 = Q_i + Q_0 \quad (28)$$

The loss of pressure on the water discharge z is determined by the results of piezometers' readings (16). The

depth of water in the tray is determined by level gauge (Spitzentaster's) readings (17).

The hydrodynamic action of the flow on the valve member is measured simultaneously with its minor displacements as indicated by the DOSM-3-0.06 dynamometer indicator. The magnitude of the opening of the level gauge (Spitzentaster), to which the dynamometer was attached.

Operating modes of water outlet varied with loss changes. In order to conduct visual monitoring of the operation of the water outlet under transitional conditions, we carried out rapid maneuvering with gates, which simulated the processes of the pump start-up or shut-down.

The experiment method has been described below. We established a certain position of the valve member above the water outlet saddle, and then the flow rate was gradually changed from the minimum value of $0.0048 \text{ m}^3 \cdot \text{s}^{-1}$ to the maximum possible value of $0.0404 \text{ m}^3 \cdot \text{s}^{-1}$ for the given laboratory setup, with Reynolds number Re within $20 \cdot 10^3 - 276 \cdot 10^3$. We estimated the relative opening of the water outlet h/D_0 (which was 0.05, 0.1, 0.15, 0.2, 0.25, 0.3, 0.4, 0.5, where D_0 is the diameter of the saddle) with the level gauge (Spitzentaster). The measurements were carried out at the steady operation mode for the direct flow of water through the water outlet at the discharge rate of $Q_w > 0$ (normal operation of the pump), and the reverse flow of water at $Q_w < 0$ (braking and turbine pump mode). For the approximate relative opening of the water outlet $h/D_0 = 0.25$ the self-identity of the hydrodynamic processes was observed at $Re \geq 10 \cdot 10^3$.

Parameters of the hydraulic flow were measured only in the steady mode, when changes in beeps and piezome-

ters were not observed at the beginning, in the middle and at the centigrade scale (°C). There is a need to consider the temperature of water to determine the water viscosity while calculating Reynolds numbers.

We carried out the studies based on the model of water outlets with the pressure pipe diameter of $D_{pl} = 200$ mm. Such a model gives a modelling scale of $\alpha_l = 10$, if the pressure pipeline of the field pump station has a diameter of 2.0 m. The model of the valve member was made of 0.8 mm galvanized steel sheet. Components of the model were carefully connected. The measurement of flow parameters in the direct motion of water was performed for eight openings of the valve member. To facilitate the comparison of data obtained with results of studies by other authors, results of experiments are presented in the form of dependencies $\zeta_{w0} = f(h/D_0)$ (Fig. 2a), and $\beta = f(h/D_0)$.

In total, we performed 62 experiments. Results of the experiments show that at $Re > 10 \cdot 10^3$ there are conditions for the flow self-similarity. While analysing results of studies of the direct water flow through the water outlet, it should be noted that experimental values of resistance coefficients ζ_{w0} clearly agree with the data of PLESEVIČIUS [1974], which are obtained for pipeline valves used in marine systems. According to the results of the research, we have chosen the following approximating dependence:

$$\zeta_{w0} = 1.3 + 0.2 \left(\frac{h}{D_0}\right)^{-1.5} \quad (29)$$

Coordinates of this dependence are as follows:

h/D_0	0.06	0.1	0.2	0.3	0.4	0.5	0.6	0.7
ζ_{w0}	20.1	7.60	3.54	2.51	2.09	1.86	1.73	1.64

As Figure 2a shows, the fitted curve based on Equation (29) passes below all other curves. This indicates that the proposed design of the water outlet has a high spillway cantilevering. According to the experimental data, the hydrodynamic action of the flow on the valve member is determined by the following dependence

$$F = \Delta p \left(\frac{\pi D_0^2}{4}\right) \varepsilon \beta = \Delta p \left(\frac{\pi D_0^2}{4}\right) \beta_1 \quad (30)$$

Where: ε = a correction factor associated with the fact that the saddle diameter is $D_3 = 1.25D_0$; $\beta_1 = \varepsilon\beta$.

Correction factor ε at $0 < h/D_0 < 0.25$ is determined by the following equation

$$\varepsilon = \left(1.25 - 0.395 \sqrt[3]{\frac{h}{D_0}}\right)^2 \quad (31)$$

The value of β is based on Equation (24). We performed 60 experiments for eight relative openings of the valve member in the reverse flow of water through the water outlet (Fig. 3).

Conditions of self-similarity take place for the reverse flow with $Re > 80 \cdot 10^3$.

As regards the dependence $\zeta_{w01} = f(h/D_0)$ based on experimental data (Fig. 3), it is possible to approximate it by the following expression:

$$\zeta_{w01} = 0.5 + 0.119 \left(\frac{h}{D_0}\right)^{-1.635} \quad (32)$$

Then, in accordance with Equation (22), the suction force factor can be found as follows:

$$\beta_n = \frac{1}{16 \zeta_{w01} \left(\frac{h}{D_0}\right)^2} = \frac{1}{16 \left[0.5 + 0.119 \left(\frac{h}{D_0}\right)^{-1.635}\right] \left(\frac{h}{D_0}\right)^2} \quad (33)$$

or:

$$\beta_n = \frac{1}{8 \left(\frac{h}{D_0}\right)^2 + 1.904 \left(\frac{h}{D_0}\right)^{0.365}} \quad (34)$$

The values of β_n , which are determined by Equation (34), correspond to the scope of large values of the coefficient determined by experiments.

Thus, as a result of laboratory studies, numerical values of resistance coefficients and hydrodynamic pressure coefficients for both direct and reverse flows of water through water outlet were obtained with a vertical motion of the valve member.

Figure 4a graphically represents results of experiments.

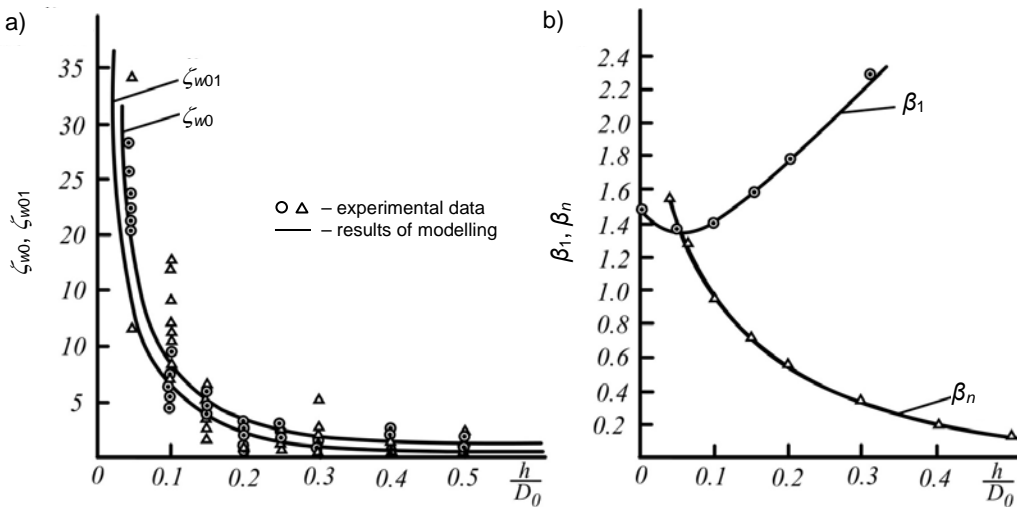

Fig. 4. Hydrodynamic features of the valve member: a) dependency diagrams $\zeta_{w0} = f(h/D_0)$, $\zeta_{w01} = f(h/D_0)$, b) dependency diagrams $\beta_1 = f(h/D_0)$, $\beta_n = f(h/D_0)$; source: own elaboration

After approximating experimental data, we confirmed the analytical expressions in the following final form:

$$\zeta_{w0} = 1.3 + 0.2 \left(\frac{h}{D_0} \right)^{-1.5} \quad (35)$$

$$\zeta_{w01} = 0.5 + 0.119 \left(\frac{h}{D_0} \right)^{-1.635} \quad (36)$$

$$\beta_1 = \varepsilon\beta = \left(1 + \frac{2}{\zeta_{w0}+1} \right) \left(1.25 - 0.395 \sqrt[3]{\frac{h}{D_0}} \right)^2 \quad (37)$$

$$\beta_n = \frac{1}{16\zeta_{w01} \left(\frac{h}{D_0} \right)^2} \quad (38)$$

These equations accurately describe the nature of experimental dependencies in the calculated range of relative openings of the valve member from $h/D_0 = 0$ to $h/D_0 = 0.3$. Figure 4a shows the results of calculations according to Equations (35)–(38) as continuous lines.

Selected approximated dependencies are used in the design of water outlets, and they are crucial while constructing a mathematical model for the operation of water outlet devices under transient conditions [SURIN 1946].

RESULTS AND DISCUSSION

Drawbacks of the most common siphon water outlet used in pumping stations are as follows: unreliable sealing, significant metal content, relatively large head losses, the need to install a vacuum breakdown valve, rigid requirements for the fluctuations of water levels in the elevated reservoir, complications with the siphon charging etc. If the pump starts with an empty pipe and the air admission valve has an insufficient area, the air can flow out in large bubbles from under the crown of the siphon line into the upper bifurcate, resulting in fluctuations of pressure which reach 20–25% of the nominal value. These fluctuations of pressure lead to the vibration of the hydraulic unit, and the

pressure in the pipeline and the entire structure [ARSHENEVSKII, POSPELOV 1980; ZAKHAROV *et al.* 1976]. The tightness in the siphon lining (general section of 0.02–0.03% of neck area) almost completely breaks the vacuum in the siphon [KONDRATYEV *et al.* 1976]. Pressure loss in siphon water outlets when working with their full section is 0.2–1.0 m, which is important for pumps with a pressure of 5–16 m [KARELIN, NOVODEREZHKIN 1980]. If the air admission valve does not work, the siphon water outlet starts to work as a siphon water receiver, and the pump unit rotates in the opposite direction with a maximum speed of 140–160% of its nominal speed (acceleration mode) [ZAKHAROV *et al.* 1976]. In the accelerated mode, the pulsation loads, vibration levels, and the tension of pump elements are 5–8 times higher than in corresponding operating modes [ZAKHAROV *et al.* 1976]. The impact of accelerating modes on the pump unit is so serious that after each output of the pump unit into acceleration, it is necessary to revise the pump. Thus, the presence of a siphon water outlet significantly complicates transitional hydromechanical processes in pumping facilities.

The indicated drawbacks of siphon water outlets prompted the development of floating water outlets [HERASYMOV, BURDIUZHHA 1981], which are characterized by high conveying capacity in operational modes, no need for lifting mechanisms, simplicity of design, low material capacity, and high reliability of work in transition processes.

Figure 5 depicts the design of a floating water outlet. Valve member 1 is located above the saddle in the form of a cylinder with a conical lower part. The valve is hermetically sealed with six internal steel rigid ribs of 8–10 mm in thickness.

The valve member is fixed in its extreme upper and lower positions by three opening limiters [ARSHENEVSKII, POSPELOV 1980]. It is beneficial to make the opening limiters tubular (trunnion) with horizontally placed brackets at the ends. One limiter, which is located along the flow, has

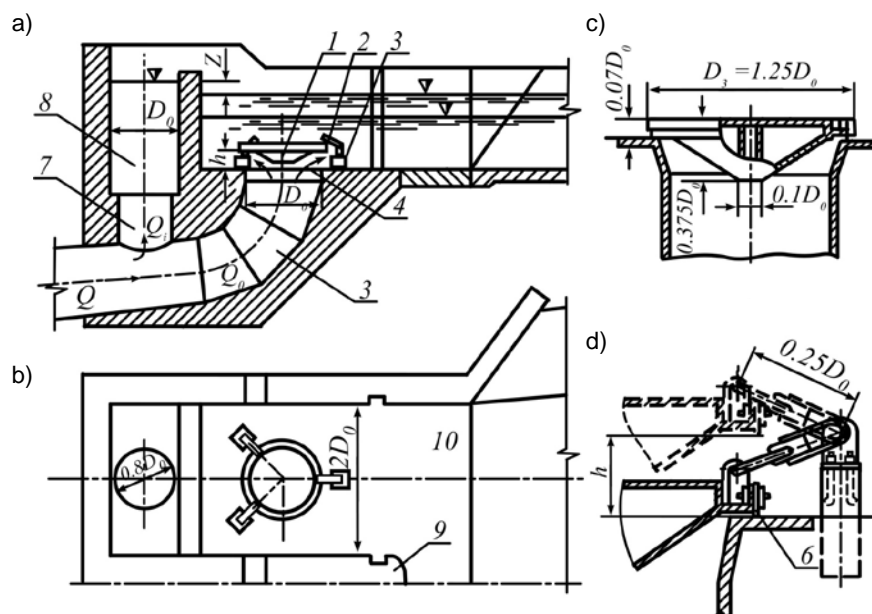

Fig. 5. Floating water outlet of pumping station: a) longitudinal profile, b) plan, c) design of valve member, d) design of valve opening limiter; source: own study

an extended vertical bracket. On supports 3 and valve member 1, staples are located in a vertical plane. The valve member is sealed with specially shaped rubber band 6, which is attached to the lower cylindrical part of the valve.

The pressure pipeline is connected to the atmosphere through pipe 7 and balancing chamber 8. Separate tanks 9, which have maintenance slots to repair valves 10, are installed in the elevated reservoir.

When the pump is switched off, water does not enter pressure pipeline 5, valve member 1 is pressed to the saddle by hydrostatic pressure of water.

When the pump is switched on, pipeline 5 is filled with water. It squeezes air through pipe 7 and chamber 8. If pipeline 5 is full, the water level in balancing chamber 8 begins to exceed the water level in the elevated reservoir. This produces hydrodynamic force F that is directed upward and attempts to raise valve member 1. Since the valve has a small unbalanced mass, the opening occurs at low pressure losses.

When the pump unit is switched off, the water leakage rate decreases, while the hydrodynamic action of the flow on valve 1 decreases. The reverse movement of water through the water outlet causes suction hydrodynamic force F_n [BRONSHTEIN, SEMENDYAEV 1962], which accelerates the lowering of valve member 1 on saddle 4. When valve 1 is closed, the elevated reservoir cannot be drawn down. The subsequent emptying of pressure pipeline 5 does not produce vacuum, since the air enters the atmosphere through pipe 7 and chamber 8.

The water outlet is distinguished by the positive nature of transient hydrodynamic processes and it can be applied in case of relatively large fluctuations in the water level in the discharge channel.

CONCLUSIONS

The study determined characteristics of floating water outlets in direct and reverse flows of water. It compared results of mathematical modelling of transient hydraulic and mechanical processes by different researchers. Thus, it is possible to define geometric dimensions of the proposed floating water outlet and check strength parameters of its elements.

The developed method for determining water outlet parameters will increase the reliability of pumping stations and, accordingly, reduce the risk of insufficient water supply to the irrigated agricultural area, and increase the probability of sustainable agricultural production.

The new construction of the water outlet can be installed in a pumping station that pumps water into an open channel to increase the reliability of the pumping station.

REFERENCES

ALTSHUL A.D., KISELEV P.G. 1975. *Gidravlika i aerodinamika (Osnovy mekhaniki zhidkosti)* [Hydraulics and aerodynamics (Fundamentals of fluid mechanics)]. 2nd ed. revised and enlarged. Moscow. Stroiizdat pp. 327.

ANDRIASHEV M.M. 1979. *Gidravlicheskiye raschety oborudovaniya vodovodov* [Hydraulic calculations of water pipelines]. Moscow. Stroiizdat pp. 104.

ARSHENEVSKII N.N., POSPELOV B.B. 1980. *Perekhodnye protsessy krupnykh nasosnykh stantsii* [Transition processes of large pumping stations]. B-ka gidrotekhnika i gidroenergetika. Iss. 66. Moscow. Energiya pp. 112.

BASHTA T.M., RUDNEV S.S., NEKRASOV B.B., BAYBAKOV O.V., KIRILLOVSKY YU.L. 1970. *Gidravlika, gidravlicheskiye mashiny i gidravlicheskiye privody: Uchebnik dlya mashinostroitel'nykh vuzov* [Hydraulics, hydraulic machines and hydraulic drives: Mechanical engineering college and university textbook]. Moscow. Mashinostroyeniye pp. 504.

BOGOMOLOV A.I., MIKHAILOV K.I. 1972. *Gidravlik: Uchebnik dlya vuzov*. [Hydraulic technician: College and university textbook]. 2nd ed. revised and enlarged. Moscow. Stroiizdat pp. 648.

BOL'SHAKOV V.A. (ed.) 1977. *Spravochnik po gidravlike* [Reference book on hydraulics]. Kyiv. Vyshcha shkola pp. 320.

BRONSHTEIN I.N., SEMENDYAEV K.A. 1962. *Spravochnik po matematike dlya inzhenerov i uchashchikhsiya vuzov* [Reference textbook on mathematics for engineers and college or university students]. Moscow. Gosudarstvennoye izdatel'stvo fiziko-matematicheskoy literatury pp. 608.

CHEBAYEVSKIY V.F., RYCHAGOV V.V., VISHNEVSKIY K.P., TRET'YAKOV A.A. 1982. *Proektirovaniye nasosnykh stantsii i ispytaniye nasosnykh ustanovok* [Designing pumping stations and testing pump units]. 3rd ed. revised and enlarged. Moscow. Kolos pp. 320.

CHUGAYEV R.R. 1975. *Gidravlika (Tekhnicheskaya mekhanika zhidkosti): Uchebnik dlya vuzov* [Hydraulics (technical fluid mechanics): College and university textbook]. Leningrad. Energiya pp. 600.

GAVRILENKO B.A., MININ V.A., ROZHDESTVENSKII S.N. 1968. *Gidravlicheskiy privod* [Hydraulic drive]. Moscow. Mashinostroyeniye pp. 502.

HERASYMOV H.H. 1993. *Perekhidni protsesy v nasosnykh ustanovkakh z poplavkovymy vodovypuskamy* [Transient processes in pumping plants with floating water outlets]. *Hidromeliorativne ta hidrotekhnichne budivnytstvo. Resp. Mizhvidomchyi n.-t. zb.* No. 20 p. 57–63.

HERASYMOV H.H., BURDIUZH A.P.D. 1981. *Vodovypusk. A. s. No. 1086061 A SSSR, E 02 V 9/06*. [Water outlet. Archived File No. 1086061 A USSR, E 02 V 9/06.] No. 3296804/29-15. Registered on February 22, 1981. Published on April, 15, 1984. Bulletin No. 141 p. 3.

IDELCHIK I.E. 1954. *Gidravlicheskiye soprotivleniya (fiziko-mekhanicheskiye osnovy)* [Hydraulic resistance (Physical and mathematical fundamentals)]. Moscow–Leningrad: Gosenergoizdat pp. 316.

IDELCHIK I.E. 1975. *Spravochnik po gidravlicheskim soprotivleniyam* [Reference book on hydraulic resistances]. 2nd ed. revised and enlarged. Moscow. Mashinostroyeniye pp. 559.

JONES G.M., SANKS R.L., TCHOBANOGLIOUS G., BOSSERMAN B.E. 2008. *Pumping station design*. 2nd ed. Butterworth-Heinemann. ISBN 978-1-85617-513-5 pp. 1104. DOI 10.1016/b978-1-85617-513-5.x5001-x.

KARELIN V.YA., NOVODEREZHNIKIN R.A. 1980. *Nasosnye stantsii gidrotekhnicheskikh sistem s osevyimi i diagonal'nymi nasosami* [Pumping stations of hydrotechnical systems with axial-flow and angular-flow pumps]. Moscow. Energiya pp. 288.

KAY M. 2008. *Practical hydraulics*. 2nd ed. Taylor and Francis. ISBN 978-0415351157 pp. 272.

KONDRATYEV V.N., SKOSAREV E.V., CHIBISOV I.T., SHAVARIN V.N. 1976. *Proektirovanie sifonnykh vodovypuskov dlya na-*

- sosnykh stantsii [Designing siphon water outlets for pumping stations]. *Gidrotekhnicheskoe stroitel'stvo*. No. 1 p. 54–56.
- KONDRATYEVA T.F. 1976. *Predokhranitel'nye klapany* [Safety valves]. 2nd ed. revised and enlarged. Leningrad. Mashinostroyeniye pp. 232.
- KOVALENKO P.I., TUGAI A.M. 1974. *Meliorativnyye gidrotekhnicheskiye sooruzheniya* [Ameliorative hydraulic facilities]. Kiev. *Budivel'nik* pp. 123.
- KURGANOV A.M., FEDOROV N.F. 1978. *Spravochnik po gidravlicheskim raschetam sistem vodosnabzheniya i kanalizatsii* [Reference book on hydraulic calculations of the water supply and sewerage systems]. 2nd ed. revised and enlarged. Leningrad. *Stroiizdat* pp. 424.
- MIKHAILOV I.E., ZOLOTUKHIN V.I. 1977. *Vlianiye vysoty vodozabornykh otverstii bashennykh vodopriyemnikov na poteri napora* [Influence of the height of water inlets of the tower water intakes on pressure loss]. *Gidrotekhnicheskoye stroitel'stvo*. No. 2 p. 27–28.
- MIKHAILOV I.E., ZOLOTUKHIN V.I. 1978. *Vybor form i razmerov bashennykh vodopriyemnikov* [Selection of shapes and sizes of tower water intakes]. *Gidrotekhnicheskoe stroitel'stvo*. No. 2 p. 24–27.
- NOVAK P., MOFFAT A.I.B., NALLURI C., NARAYANAN R.A.I.B. 2007. *Hydraulic structures*. 4th ed. Taylor and Francis. ISBN 0-203-96463-2 pp. 736.
- PEPLOV E.E., KOKAYA N.V. 1956. *Zatvor s vozdušnoy kameroy* [Air shutter]. *Gidrotekhnika i melioratsiya*. No. 6 p. 37–41.
- PLESEVIČIUS P.I. 1974. *Vliyaniye vysoty pod'yema tarel'i na gidravlicheskiye soprotivleniye armatury zapornykh klaponov truboprovodov sudovykh sistem* [Impact of the height of plate lifting on the hydraulic resistance of valve members of marine systems' pipelines]. *Trudy Leningradskogo korablistroitel'nogo instituta*. No. 94 p. 74–84.
- SHOMAYRAMOV M., NORKULOV B., RAKHMANOV J., TADJIYEVA D., SUYUNOV J. 2019. Experimental researches of hydraulic vacuum breakdown devices of siphon outlets of pumping stations. In: *Construction the Formation of Living Environment. XXII International Scientific Conference (FORM-2019)*. Tashkent, Uzbekistan. Eds. A. Volkov, A. Pustovgar, T. Sul-tanov, A. Adamtsevich. E3S Web Conf. 97 05009. DOI 10.1051/e3sconf/20199705009.
- SLISSKII P.M. 1974. *Gidravlicheskiye raschety napornykh orositel'nykh sistem s regulirovaniyem po nizhnemu befu* [Hydraulic calculations of pressure irrigation systems with downstream control]. *Trudy Moskovskogo energeticheskogo instituta*. No. 203 p. 134–139.
- SLISSKIY S.M. 1970. *Gidravlika zdaniy gidroelektrostantsii* [Hydraulics of hydroelectric power station premises]. Moscow. *Energiya* pp. 424.
- STEPANOV P.M., OVCHARENKO I.KH., SKOBELTSYN YU.A. 1984. *Spravochnik po gidravlike dlya melioratorov* [Reference textbook on hydraulics for irrigation engineers]. Moscow. *Kolos* pp. 207.
- SURIN A.A. 1946. *Gidravlicheskiy udar v truboprovodakh i bor'ba s nim* [Water hammer in pipelines and combatting it]. Moscow. *Tranzheldorizdat* pp. 372.
- TSUKANOVA E.A., BARZHANSKII E.E., RAKHMANOV ZH.R. 1975. *Opredeleniye koeffitsientov poter tsilindricheskikh klaponov* [Determination of loss coefficients for cylindrical valves]. *Mekhanika mashinostroyeniya*. No. 49 p. 77–84.
- VALIPOUR M. 2017. Global experience on irrigation management under different scenarios. *Journal of Water and Land Development*. No. 32 p. 95–102. DOI 10.1515/jwld-2017-0011.
- VIL'NER YA.M., KOVALEV YA.T., NEKRASOV B.B. 1976. *Spravochnoye posobiye po gidravlike, gidromashinam i gidroprivodam* [Reference textbook on hydraulics of hydraulic machines and hydraulic drives]. Ed. B.B. Nekrasov. Minsk. *Vysheishaya shkola* pp. 419.
- YUREV A.S. 2001. *Spravochnik po raschetam gidravlicheskiykh i ventilyatsionnykh sistem* [Reference textbook on calculations for hydraulic and ventilation systems]. Ed. A.S. Yurev. Saint Petersburg. ANO NPO Mir i semya. ISBN 5-94365-022-9 pp. 1154.
- ZAKHAROV O.V., KARELIN V.YA., NOVODEREZHKIN R.A. 1976. *Opyt ekspluatatsii krupnykh osevykh nasosov na magistral'nykh kanalakh* [Experience of operating large axial pumps on major supply channels]. *Gidrotekhnicheskoye stroitel'stvo*. No. 8 p. 20–24.