

He Huang<sup>1,3</sup>,  
Qiurui Liu<sup>2</sup>

# Intelligent Retail Forecasting System for New Clothing Products Considering Stock-out

DOI: 10.5604/12303666.1227876

<sup>1</sup> College of Fashion and Design,  
Donghua University,  
Shanghai, China  
E-mail: huanghedhu@gmail.com;

<sup>2</sup> College of Public Administration,  
Huazhong Agricultural University,  
Wuhan, China  
E-mail: qiurui.liu@hotmail.com

<sup>3</sup> Faculty of Management,  
McGill University,  
Montreal, Canada

## Abstract

*Improving the accuracy of forecasting is crucial but complex in the clothing industry, especially for new products, with the lack of historical data and a wide range of factors affecting demand. Previous studies more concentrate on sales forecasting rather than demand forecasting, and the variables affecting demand remained to be optimized. In this study, a two-stage intelligent retail forecasting system is designed for new clothing products. In the first stage, demand is estimated with original sales data considering stock-out. The adaptive neuro fuzzy inference system (ANFIS) is introduced into the second stage to forecast demand. Meanwhile a data selection process is presented due to the limited data of new products. The empirical data are from a Canadian fast-fashion company. The results reveal the relationship between demand and sales, demonstrate the necessity of integrating the demand estimation process into a forecasting system, and show that the ANFIS-based forecasting system outperforms the traditional ANN technique.*

**Key words:** intelligent forecasting system, demand estimation, stock out, adaptive neuro fuzzy inference system, new clothing product.

motion, macroeconomics, etc. [3]; (4) acquiring an accurate demand pattern is not easy because of stock-out, thus using historical sales data instead of demand data to implement forecasting is a common way.

To explore the issue of clothing retail forecasting, some papers have investigated statistical methods, while others have studied artificial intelligence (AI) techniques. In recent years, hybrid techniques have aroused the interest of experts. Among the various hybrid techniques, the adaptive neuro fuzzy inference system (ANFIS) is a competent alternative that combines the advantages of the artificial neural network (ANN) and fuzzy system [4]. In addition, previous studies heavily focus on developing forecasting models/techniques, but ignore dataset processing. In fact, the purpose of retail forecasting is to satisfy consumer demand. Therefore integrating the demand estimation process into the forecasting system should be taken into account.

As a result, this study aims to design an intelligent system for the demand forecasting of new clothing products. This system comprises of a demand estimation stage and demand forecasting stage. The empirical data are from a Canadian fast-fashion company.

## Forecasting techniques in the clothing industry

As time goes on and computer technology develops, more and more forecasting

models/techniques have been created for the clothing industry.

### Traditional techniques

An inspection of previous studies reveals that classical statistical methods are extensively used [5-7]. However, most methods such as regression models are only efficient for seasonal or cyclical data [8], and limited to a linear structure. Moreover the demand for clothing products is affected by numerous factors, so that statistical methods may not be capable of achieving a satisfactory result. Moreover a substantial amount of data are often required to generate good results, but the data available for new clothing products are limited. Therefore AI techniques have gained more attention [9-11]. Despite the fact that AI techniques could obtain satisfactory results in many studies, it is not easy to achieve a balance between result accuracy, high computational speed and system stability. Consequently to combine the advantages of different techniques, hybrid techniques were investigated.

### Hybrid techniques

A great quantity of studies have presented that hybrid techniques lead to better performance. As a hybrid technique, ANFIS combines the knowledge representation ability of the fuzzy system and the learning ability of ANN. Consequently ANFIS has been widely used for forecasting in different industries [12-14]. However, there is not an adequate quantity of studies in the literature on retail forecasting with ANFIS in the clothing industry.

## Introduction

For the clothing industry, it is critical to improve the accuracy of demand forecasting [1]. A good forecasting system could avoid problems such as lost sales, inadequate inventory level, inferior customer service, etc. However, four main factors increase the difficulty in clothing forecasting: (1) The clothing supply chain is considered inflexible and complex with many sectors and companies; [2] it results in the high sensitivity of the bullwhip effect; (2) a large number of new products introduced to each collection leads to extensive historical data for past products, but little data for new products; (3) The sales data of clothing products is usually noisy and affected by multiple factors, such as weather, pro-

## Method and dataset

### Proposed system and data selection

As an important information flow, demand information greatly influences the performance of clothing retail companies. However, unlike other areas where the past is a great predictor of the future, such as grocery or hardware retail, there is no amount of historical data or experiences that can truly and effectively predict how customers would react to new clothing products. This reality is further made complex by the fact that demand is affected by numerous factors, and it is difficult to acquire the demand pattern because of stock-out. In addition, traditional techniques have certain disadvantages such as an inability to address a complex non-linear structure, a need for more historical data, the production of relatively worse results, etc. In this section, a two-stage intelligent retail forecasting system that could remedy the shortcomings of traditional techniques is proposed, see **Figure 1**. In the first stage, demand is estimated with original sales data considering stock-out. In the demand forecasting stage, ANFIS is employed and the significant variables affecting demand are selected as the ANFIS inputs. Given the data of new clothing products is limited, a data selection process is integrated in this system.

To validate the effectiveness of this system, we applied it to a Canadian fast-fashion company. The company has hundreds of stores across North America and a large Asian sourcing base.

The data selection process is explained as follows:

- Based on the concept of ANFIS and data splitting theory, two product groups are identified: group 1 has 56 items with full-year data from 2014, and group 2 has 8 items with data from several months in 2015.
- All products belong to the same product department, and there are three product classes in group 1.
- With the help of company experts, products in group 1 are selected as comparable items to products in group 2. Indeed, given the limited data for new products, many fashion companies consider the performance of comparable items, such as ZARA [15].
- For each item, daily data from each store are collected rather than aggregated data.

In addition, the life cycle of fast-fashion products is short, usually 6-10 weeks [16]. In our database, the products in group 2 include a complete product life cycle of 10 weeks. Therefore, in this study, the forecasting time period is 10 weeks with a weekly horizon.

### Demand estimation

The occurrence of stock-out results in inequality between sales and demand [17]. In other words, if there is no stock-out, sales quantity can be regarded as demand quantity. Therefore the basic idea of stage one is using the sales data without stock-out to deduce demand. In our database, if the daily inventory is zero,

it indicates that stock-out may happen. We also realize that the demand on each day of the week varies a lot. For instance, sales at the weekend are usually stronger than those on weekdays. Then each day of the week has different sales weight. We express the weekly demand of each item  $D_i^m$  as below:

$$D_k^m = \sum_{t=1}^T D_{tk}^m \quad (1)$$

$$D_{tk}^m = \sum_{d=1}^7 (S_{tkd}^m * V_{tkd}^m) / \sum_{d=1}^7 (W_d * V_{tkd}^m) \quad (2)$$

$$W_d = S'_d / \sum_{d=1}^7 S'_d \quad (3)$$

Where:

$D_{tk}^m$  – the demand of item  $m$  in store  $t$  in week  $k$ .  $m = (1, 2, \dots, M)$ ;  $t = (1, 2, \dots, T)$ ;  $k = (1, 2, \dots, K)$ .

$D_k^m$  – the demand of item  $m$  in week  $k$  which aggregates the demand of all stores.

$S_{tkd}^m$  – sales quantity of item  $m$  in store  $t$  on day  $d$  of week  $k$ .

$V_{tkd}^m$  – the binary variable equals 0 when stock-out may exist (daily inventory = 0), otherwise 1 (daily inventory > 0).

$W_d$  – sales weight of day  $d$ .

$d$  – index of the day,  $d = (1, 2, \dots, 7)$ , Monday is 1 and Sunday – 7.

$S'_d$  – aggregated sales quantity on day  $d$ , used to compute  $W_d$ .

The basic idea behind this approach is consistent with one of the methods discussed in [18], although our approach is slightly different. To generate the sales weights, the daily sales of group 1 are aggregated by each day of the week, then the aggregated sales are divided by the

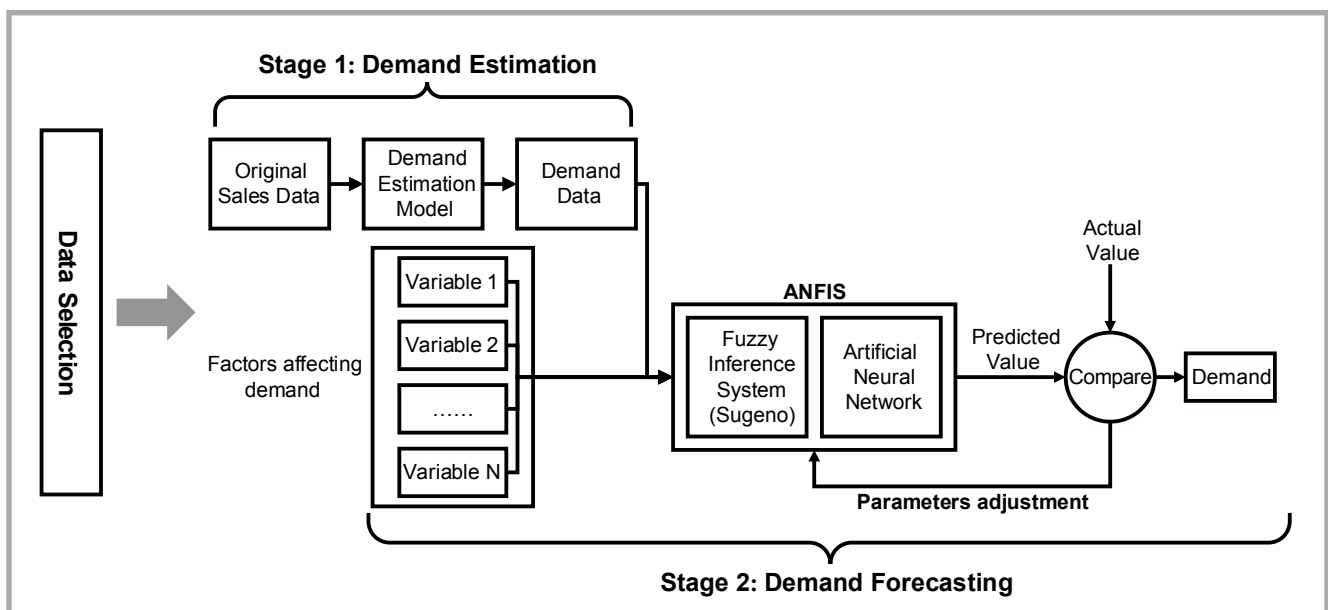

**Figure 1.** Schematic of the intelligent retail forecasting system.

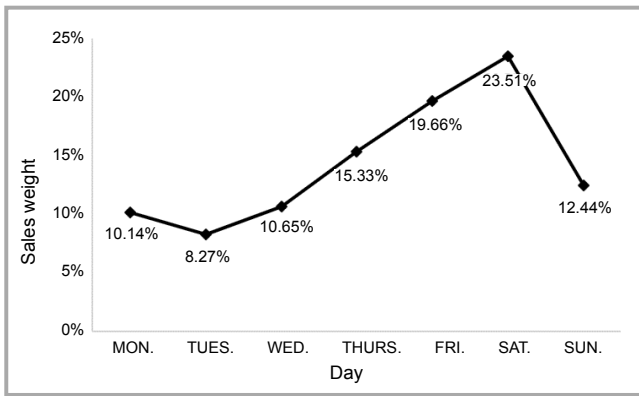

Figure 2. Sales weights for each day of the week.

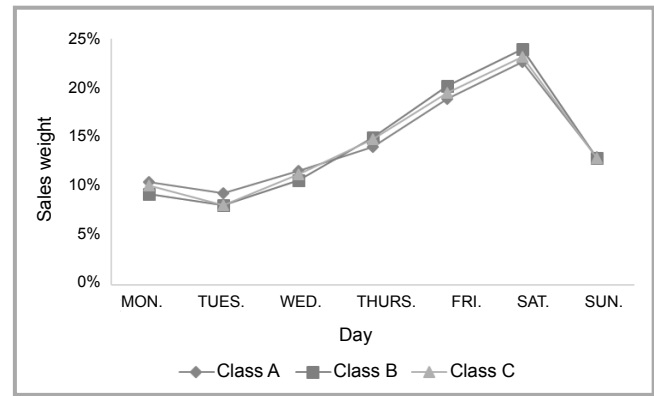

Figure 3. Sales weights for different classes.

total sales of the whole week, see *Equation 3*. *Figure 2* shows the results.

The three days with the highest sales are Saturday, Friday and Thursday, with sales weights of 23.51%, 19.66%, and 15.33%, respectively. Surprisingly sales on Sunday are relatively low. The main reason might be that retail stores have shorter business hours on Sunday in North America. Then another question is whether the sales weights observed would vary depending on the products in different classes, even if they belong to the same department. We then examined the sales weights for the three classes of group 1. As expected, the sales quantity of each class is different, but the sales weights are remarkable consistent, see *Figure 3*. It demonstrates that product class has no significant impact on sales weights, and hence the sales weights in *Figure 2* can be used for each item. After obtaining the sales weights, the weekly demand of each item in each store was computed by *Equation 2*, and then the weekly demand of each item that aggregates all stores was generated by

*Equation 1*. The weekly demand obtained instead of weekly sales was used as the inputs of the second stage.

### Demand forecasting

It is well known that AI techniques, such as the fuzzy system and ANN, have the capability of imitating human reasoning. ANN has a strong capability of learning with parallel data. However, given knowledge is integrated into the whole network and cannot be broken up into individual parts; the network is essentially a black-box. The fuzzy system is good at reasoning with the linguistic information obtained from expert knowledge. However, the learning capability is inferior and cannot adapt itself to a new environment [19]. As a hybrid technique, first proposed by [20], ANFIS combines the learning ability of ANN with the semantic transparency of fuzzy systems. Meanwhile the domain knowledge represented as fuzzy rules and linguistic variables is integrated into ANFIS. In this study, the Sugeno-type fuzzy inference system (FIS) rather than the Mamdani-type FIS is em-

ployed, which has become common practice in ANFIS implementation [12]. All functions were carried out in MATLAB.

The structure of a typical ANFIS is shown in *Figure 4*. For ease of illustration, it is assumed that each variable is fuzzified by two fuzzy sets. The node functions of each layer are explained below:

ANFIS inputs are represented as neuron  $x_i$  ( $i = 1, 2, \dots, n$ ). Here, they are the factors affecting demand. Each neuron simply passes external crisp signals to Layer 1.

*Layer 1 (Fuzzification Layer):* Neuron  $F_{ij}$  ( $i = 1, 2, \dots, n; j = 1, 2$ ) is the linguistic label corresponding to the fuzzy set associated with the input. The neuron function can be modelled by the fuzzy membership function (MF).

$$\text{Output}_{ij}^1 = \mu F_{ij}(x_i) = \text{membership function format, } i = 1, 2, \dots, n, j = 1, 2.$$

*Layer 2 (Rule Layer):* Each neuron  $w_l$  ( $l = 1, 2, \dots, L$ ) corresponds to a fuzzy

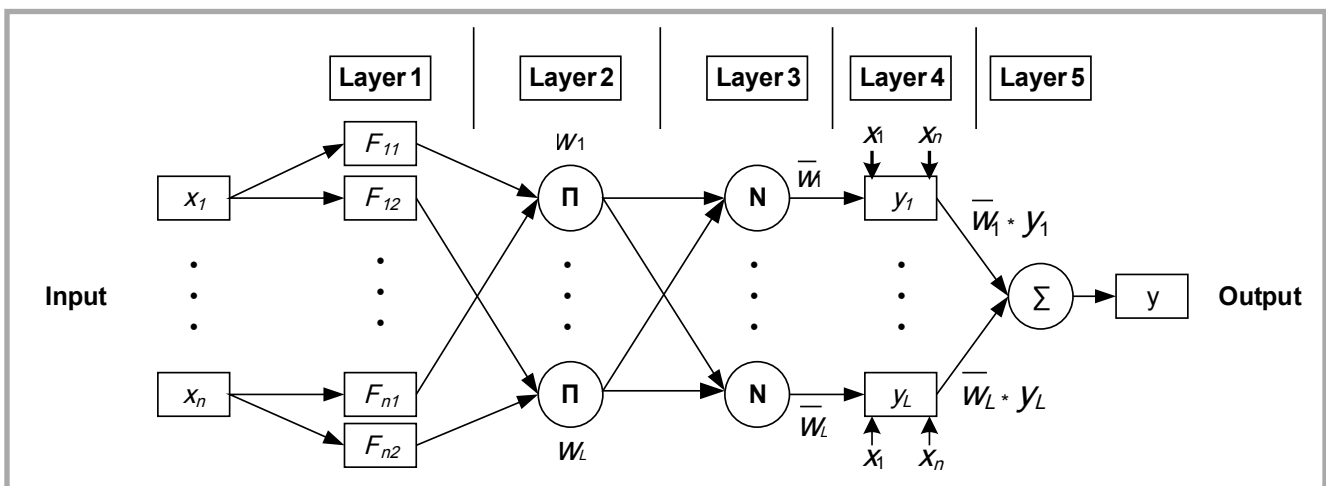

Figure 4. Structure of ANFIS.

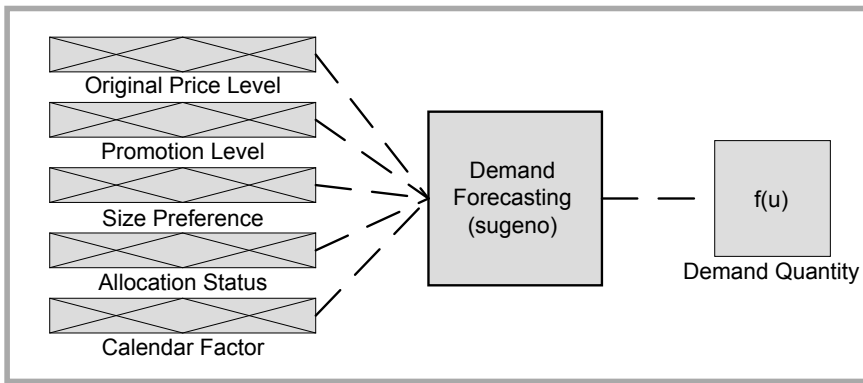

Figure 5. Sugeno-type fuzzy inference system.

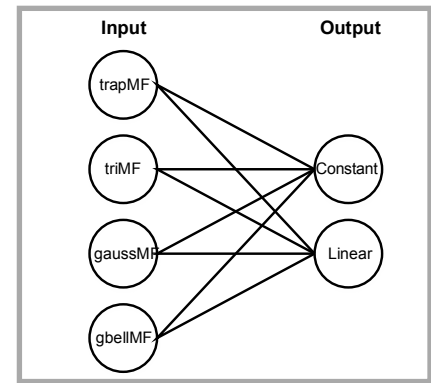

Figure 6. Different MF combinations for ANFIS structure.

rule and functionally computes the firing strength. The neuron function should be a certain T-norm function, such as,

$$Output^2_l = w_l = \prod_{i=1}^n \mu F^l_i(x_i), \\ l = 1, 2, \dots, L.$$

**Layer 3 (Normalization Layer):** Neuron  $w_l$  ( $l = 1, 2, \dots, L$ ) determines the normalised firing strength. For a given rule, the ratio between the firing strength and the sum of the firing strengths of all rules represents the normalised firing strength.

$$Output^3_l = \bar{w}_l = w_l / \sum_{l=1}^L w_l, l = 1, 2, \dots, L.$$

**Layer 4 (Defuzzification Layer):** Neurons  $y_l$  ( $l = 1, 2, \dots, L$ ) compute the consequent of the rules. The neuron function in this layer is a linear function.

$$Output^4_l = \bar{w}_l y_l = \bar{w}_l (p^l_0 + p^l_1 x_1 + \dots + p^l_n x_n) \\ l = 1, 2, \dots, L.$$

**Layer 5 (Summation Neuron Layer):** Neuron  $y$  determines the final output of ANFIS by computing the sum of the results of all defuzzification neurons.

$$Output^5 = y = \sum_{l=1}^L \bar{w}_l * y_l = \sum_{l=1}^L w_l * y_l / \sum_{l=1}^L w_l$$

As discussed earlier, neuron  $x_i$  are the inputs of ANFIS, which are the factors affecting demand. Therefore selecting the appropriate factor is important. Furthermore it is usually difficult to analyse qualitative variables with conventional methods. However, ANFIS is a powerful technique to cope with both quantitative and qualitative variables. By interviewing company experts and reviewing previous literature, five factors were determined.

- **Original Price Level:** This variable not only affects the demand pattern,

but also determines the target customers. It has three fuzzy sets: high, medium and low.

- **Promotion Level:** Some previous studies used “promotion” and “no promotion” as the fuzzy sets. In fact, for a given product, it sets the final sales price after more than one markdown, and the promotion level varies between normal weekends and big holidays. Meanwhile different promotional levels have different impacts on customer consumption. Therefore the “promotion level” was introduced, which is associated with three fuzzy sets: high, medium and low.

- **Size Preference:** Unlike colour preference, which changes every year or even every season, size preference is relatively stable. The main reason is that the target customers in a specific city are stable. Three fuzzy sets were determined: high, medium and low.

- **Allocation Status:** In the planning stage, not every item is allocated to each store. Some items are allocated to all stores, while others are not. The allocation strategy also affects the demand pattern. Two fuzzy sets were identified: normal and special.

- **Calendar Factor:** It is easy to observe that holidays or big events influence demand. For example, the sales on Black Friday are extremely high, whereas those on normal workdays are low. This variable has two fuzzy sets: normal and special.

It should be noted that although colour preference also has a great influence on demand, the large number of existing colours and new ones introduced every season make it impractical to identify the fuzzy sets. After determining the five variables, four main steps were implemented to build a robust ANFIS.

In the first step, determining the training and validation datasets is important. Given comparable products have similar demand patterns, it is reasonable to use such data rather than random product data for forecasting. Consequently group 1 data were used as training data to build the networks. Group 2 data were used as validation data to validate the reliability of the networks. Furthermore given the variables were fuzzed by several fuzzy sets, with the help of company experts, numerical scales were used to convert linguistic labels to numerical data.

In the second step, a Sugeno-type FIS (see Figure 5) is constructed for ANFIS. Determining the MF type of input variables is an important but complex task. To obtain the best performance, different experiments were prepared for four commonly used MFs: the triangular MF (triMF), trapezoidal MF (trapMF), generalised bell MF (gbellMF) and Gaussian MF (gaussMF). The output function has two types, constant and linear, and experiments prepared for both functions were conducted as well. The 8 different MF combination experiments used to identify the best forecasting capability of the ANFIS structure are shown in Figure 6.

In the training step, the ANFIS learning algorithm is used to optimise FIS parameters. The hybrid algorithm, consisting of the least squares approach and back-propagation gradient descent approach, was utilised. The ANFIS structure with 5 inputs and 1 output was trained for 100 epochs with a 0.01 error tolerance. Considering the overfitting problem, the model was run ten times for each MF combination with varying the parameter. Group 1 data were used for this process. With different experiments, Gauss

**Table 1.** Example rules of Sugeno-type FIS.

Rule NO.	Input					Output
	Original price level ( $x_1$ )	Promotion level ( $x_2$ )	Size preference ( $x_3$ )	Allocation status ( $x_4$ )	Calendar factor ( $x_5$ )	
1	Low	High	Medium	Special	Normal	$F_1(x_1, x_2, x_3, x_4, x_5)$
2	Medium	Medium	Low	Normal	Special	$F_2(x_1, x_2, x_3, x_4, x_5)$
3	High	Low	Medium	Special	Normal	$F_3(x_1, x_2, x_3, x_4, x_5)$
4	High	Medium	Low	Normal	Special	$F_4(x_1, x_2, x_3, x_4, x_5)$
5	Medium	Low	High	Special	Normal	$F_5(x_1, x_2, x_3, x_4, x_5)$

**Table 2.** Demand and sales patterns of a specific product (unit).

Week	1	2	3	4	5	6	7	8	9	10
Sales quantity	285	569	708	766	743	607	432	354	331	215
Demand quantity	391	657	912	941	891	888	634	553	433	355
Difference	106	88	204	175	148	281	202	199	102	140

**Table 3.** Forecasting performances of ANFIS and ANN.

Product No.	MAPE (ANFIS)	MAPE (ANN)	Difference	MSE (ANFIS)	MSE (ANN)	Difference
1	7.45%	29.05%	21.60%	4.450.55	35,608.07	31,157.52
2	9.02%	31.70%	22.68%	6,098.67	38,900.83	32,802.16
3	17.27%	37.80%	20.53%	27,468.70	84,127.40	56,658.70
4	6.37%	28.42%	22.05%	3,291.09	32,169.09	28,878.00
5	10.72%	35.69%	24.97%	6,765.71	76,841.22	70,075.51
6	8.59%	33.41%	24.82%	5,642.73	58,466.45	52,823.72
7	11.42%	40.88%	29.46%	7,654.59	104,590.77	96,936.18
8	14.43%	32.90%	18.47%	9,851.00	42,346.01	32,495.01
Average	10.66%	33.73%	23.07%	8,902.88	59,131.23	50,228.35

Data source: calculated using MATLAB

MF and Constant MF were chosen for inputs and outputs, respectively. Since each rule in ANFIS is represented as “If input, Then output”, 108 Sugeno-type FIS rules were generated. **Table 1** shows example rules.

The last step is measuring the forecasting capacity of the system. Group 2 data were used, which include 8 items with a complete product life cycle of 10 weeks.

## Results and discussion

### Technique comparison

The traditional ANN technique was introduced to facilitate a comparison with the system proposed. To construct the ANN network, the forecasted demand value is generated by the vectors of the five variables (original price level, promotion level, size preference, allocation status and calendar factor), and the out-

put is the value of forecasted demand. The same datasets of ANFIS were used. The model with 5 inputs and 1 output was trained for 1000 epochs with a 0.01 error tolerance. The backpropagation rule was used for the training process, and all datasets were normalised between 0 and 1. The network was also run ten times for each network architecture. Three hidden layers with 10-10-11 neurons were identified. The learning rate coefficient  $\eta$  was 0.5 and the momentum  $\mu = 0.7$ .

In addition, to compare the forecasting capability of the system proposed and ANN, two widely used accuracy measures were chosen: the mean absolute percentage error (MAPE) and mean square error (MSE).

### Results comparison

For most clothing companies, past sales data are usually used for product planning, allocation decision, inventory management, etc. If products are always available for sales and without stock-out, then the demand and sales information would be identical. However, due to the demand for clothing products being affected by multiple factors and many factors are unpredictable or uncontrollable, stock-out is rarely avoided, causing the amount sold to be less than the actual demand [17]. Therefore one of the main purposes in this study is to consider stock-out when implement forecasting. The first stage is estimating demand data based on original sales. Aggregated demand and sales data of the training and validation datasets are shown in **Figure 7**, and **Table 2** presents data of a specific product.

As expected, the demand quantities are significantly higher than those for sales, which means that the sales data cannot accurately reflect real customer demand.

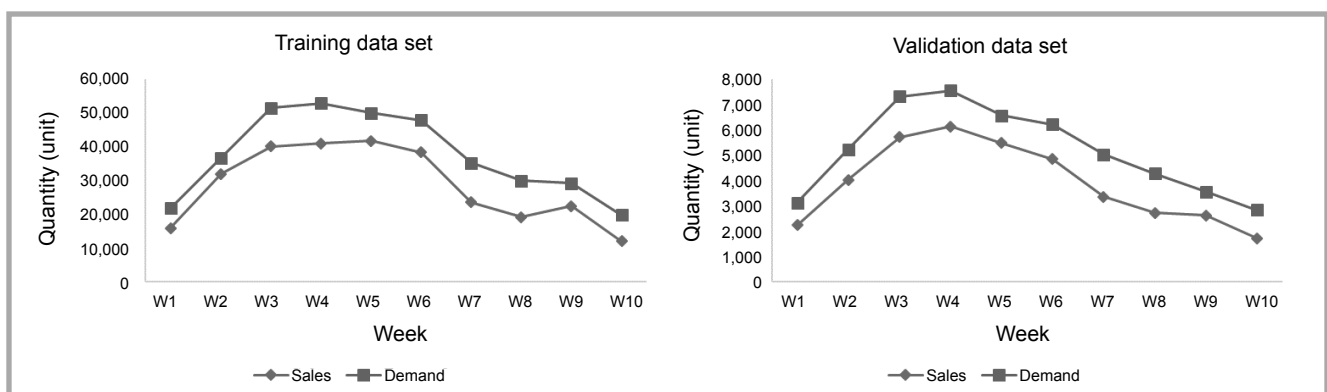

**Figure 7.** Demand and sales patterns of datasets.

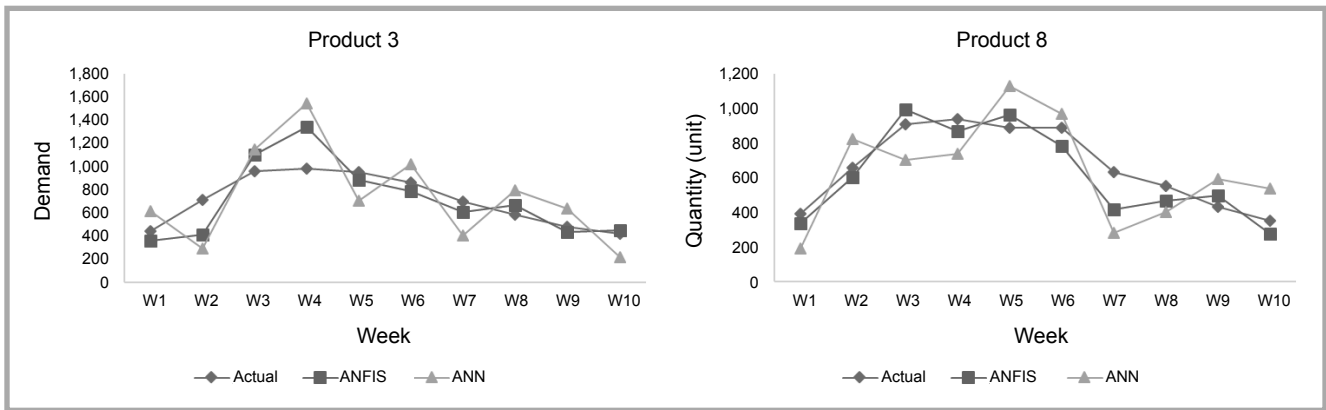

Figure 8. Weekly data of products 3 and 8.

In other words, if the company just uses sales data as the input of its forecasting system, it would lead to a certain amount of lost sales. Eventually, the total revenue must be affected. As a result, it is essential to integrate the demand estimation stage into the forecasting system.

In addition, forecasting performances were compared between the ANFIS-based system proposed (ANFIS, for simplification) and ANN, see **Table 3**.

According to the MAPE and MSE values, the ANFIS-based system significantly increases the forecasting accuracy compared with ANN. However, we noticed that sometimes the forecasting results are not very close to the real demand, see **Figure 8**. The forecasted values of product 3 in weeks 2 and 4 are relatively far from the real demand compared with the performance of other weeks. Such a situation is also observed with product 8 in week 7. A possible reason is that the variables may not fully encapsulate demand behaviour. Indeed different factors have

different impacts on demand, but they are too numerous to establish an exhaustive list, and some are consistently unavailable, such as weather, political factors and competitors' strategies [21]. Nevertheless, apart from the special points, the ANFIS-based system can generally achieve values that are close to the real demand. The comparison results clearly demonstrate that the system proposed outperforms the traditional ANN technique.

Furthermore the forecasting capability was also compared with the company's current approach. Commercial forecasting software is integrated into their enterprise resource planning (ERP) system. However, it is well known that commercial software is usually designed for universal companies and is not a good fit for a specific company. Moreover this software is inadequate for new product forecasting, thus company experts need to make adjustments with their subjective knowledge to a baseline computed by the software. The results are usually inaccurate and unreliable, and this task would be extremely tedious if the number of new products is large. More importantly, the company failed to consider the issue of demand estimation, and thus their results are only sales quantities. With such a consideration, it is not appropriate to compare the demand quantities forecasted by our system and the sales quantities the company computed by using MSE and MAPE. However, the gap between the two curves strongly indicates the lost sales ignored by the company, see **Figure 9**. Such a situation would result in enormous losses in the long run. In fact, some clothing companies have attempted to develop their individual customised forecasting system [21] based on the company's actual situation with the consideration of more factors. If the demand estimation process is integrated into their customised system, we believe lost sales and end-of-season inventories could be reduced, meanwhile the retail efficiency and total revenue could be improved.

rate and unreliable, and this task would be extremely tedious if the number of new products is large. More importantly, the company failed to consider the issue of demand estimation, and thus their results are only sales quantities. With such a consideration, it is not appropriate to compare the demand quantities forecasted by our system and the sales quantities the company computed by using MSE and MAPE. However, the gap between the two curves strongly indicates the lost sales ignored by the company, see **Figure 9**. Such a situation would result in enormous losses in the long run. In fact, some clothing companies have attempted to develop their individual customised forecasting system [21] based on the company's actual situation with the consideration of more factors. If the demand estimation process is integrated into their customised system, we believe lost sales and end-of-season inventories could be reduced, meanwhile the retail efficiency and total revenue could be improved.

## Conclusions

To sum up, by first observing the sales and demand patterns of datasets, the system proposed could significantly reduce lost sales. In addition, the forecasting capabilities of the system proposed and ANN were compared. The results demonstrate that the system proposed outperforms ANN. Moreover the forecasting performance of the system proposed was compared with the company's current approach. Given the company's approach forecasted only with respect to sales, lost sales were observed from the gap between the demand quantities our system forecasted and the sales quantities the company computed. Nevertheless more data is required to obtain robust sales weights, and the variables affecting

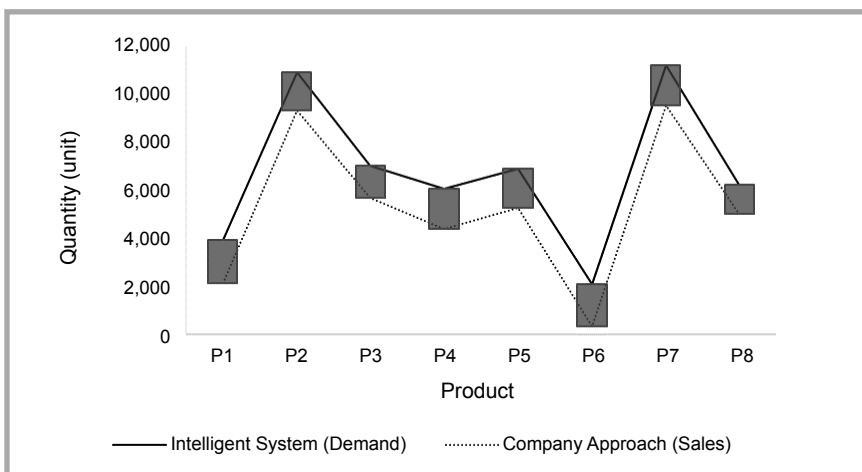

Figure 9. Forecasting results of the intelligent system and company approach.

demand should be optimised continuously. However, given the limitation of our database, these improvements should be taken into account in future work.

## Summary

This study aims to forecast the demand for new clothing products. A two-stage intelligent retail forecasting system was designed and applied to a Canadian fashion company. In the first stage, demand is estimated based on original sales. ANFIS is employed in stage two to forecast weekly demand. Meanwhile a data selection process is presented due to the limited data for new products. According to the results and discussion, the system proposed is well suited for the clothing industry.

## Acknowledgments

The authors would like to thank the company for providing data and expert knowledge. This research is supported by the Chinese Scholarship Council (NO. 201406630046 and NO. 201406240017).

## References

1. Lenort R and Besta P. Hierarchical Sales Forecasting System for Apparel Companies and Supply Chains. *Fibres and Textiles In Eastern Europe* 2013; 21, 6(102): p. 7-11.
2. Şen A. The US fashion industry: A supply chain review. *International Journal of Production Economics* 2008; 114(2): p. 571-593.
3. Wong WK and Guo ZX. A hybrid intelligent model for medium-term sales forecasting in fashion retail supply chains using extreme learning machine and harmony search algorithm. *International Journal of Production Economics* 2010; 128(2): p. 614-624.
4. Babuška R and Verbruggen H. Neuro-fuzzy methods for nonlinear system identification. *Annual Reviews in Control* 2003; 27(1): p. 73-85.
5. Mostard J, Teunter R and de Koster R. Forecasting demand for single-period products: A case study in the apparel industry. *European Journal of Operational Research* 2011; 211(1): p. 139-147.
6. Ozbek A, et al. Prediction of Turkey's Denim Trousers Export Using Artificial Neural Networks and the Autoregressive Integrated Moving Average Model. *Fibres & Textiles in Eastern Europe* 2011; 19, 3, (86): p. 86.
7. Ureyen ME and Kadoglu H. The prediction of cotton ring yarn properties from AFIS fibre properties by using linear regression models. *Fibres and Textiles in Eastern Europe* 2007; 15, 4(63): p. 63.
8. Kuo RJ, Wu P and Wang C. An intelligent sales forecasting system through integration of artificial neural networks and fuzzy neural networks with fuzzy weight elimination. *Neural networks* 2002; 15(7): p. 909-925.
9. Frank C, et al. Forecasting women's apparel sales using mathematical modeling. *International Journal of Clothing Science and Technology* 2003; 15(2): p. 107-125.
10. Hui CL et al. Learning-based fuzzy colour prediction system for more effective apparel design. *International Journal of Clothing Science and Technology* 2005; 17(5): p. 335-348.
11. Au K-F, Choi T-M and Yu Y. Fashion retail forecasting by evolutionary neural networks. *International Journal of Production Economics* 2008; 114(2): p. 615-630.
12. Wang F-K, Chang K-K and Tzeng C-W. Using adaptive network-based fuzzy inference system to forecast automobile sales. *Expert Systems with Applications* 2011; 38(8): p. 10587-10593.
13. Bektas Ekici B and Aksoy UT. Prediction of building energy needs in early stage of design by using ANFIS. *Expert Systems with Applications* 2011; 38(5): p. 5352-5358.
14. Aksoy A, Ozturk N and Sucky E. A decision support system for demand forecasting in the clothing industry. *International Journal of Clothing Science and Technology* 2012; 24(4): p. 221-236.
15. Gallien J, et al. Initial Shipment Decisions for New Products at Zara. *Operations Research* 2015; 63(2): p. 269-286.
16. Bergvall-Forsberg J and Towers N. Creating agile supply networks in the fashion industry: A pilot study of the European textile and clothing industry. *Journal of the Textile Institute* 2007; 98(4): p. 377-386.
17. Wecker WE. Predicting demand from sales data in the presence of stockouts. *Management Science* 1978; 24(10): p. 1043-1054.
18. Garro A. *New product demand forecasting and distribution optimization: a case study at Zara*. Massachusetts Institute of Technology, 2011.
19. Negnevitsky M. *Artificial intelligence: a guide to intelligent systems*. Pearson Education, 2005.
20. Jang J-SR. ANFIS: adaptive-network-based fuzzy inference system. *Systems, Man and Cybernetics, IEEE Transactions on*, 1993. 23(3): p. 665-685.
21. Thomassey S. Sales forecasts in clothing industry: The key success factor of the supply chain management. *International Journal of Production Economics* 2010; 128(2): p. 470-483.

Received 13.04.2016 Reviewed 23.06.2016



## Institute of Biopolymers and Chemical Fibres

*FIBRES &  
TEXTILES  
in Eastern  
Europe  
reaches all  
corners of the  
world!  
It pays to  
advertise your  
products  
and services in  
our magazine!  
We'll gladly  
assist you in  
placing your  
ads.*

**FIBRES & TEXTILES  
in Eastern Europe**

ul. Skłodowskiej-Curie 19/27  
90-570 Łódź, Poland

Tel.: (48-42) 638-03-00  
637-65-10

Fax: (48-42) 637-65-01

e-mail:

**ibwch@ibwch.lodz.pl  
infor@ibwch.lodz.pl**

Internet:

<http://www.fibtex.lodz.pl>