

KRZYSZTOF FILIPOWICZ
MARIUSZ KUCZAJ
PAWEŁ GRUSZKA

Experimental mechanical security assessment used in torsionally flexible Raptor-SK couplings

Dodge®Raptor series couplings belong to inseparable, mechanical, and torsionally flexible couplings with the possibility of compensating for the misalignment of axes. In the couplings with the Raptor-SK design, shear pins were additionally applied to protect the drive system from overload. The use of "fuses" in the coupling in the form of shear pins limits the value of the transferred torque to a set (safe) value; beyond which, it is cut off and the drive is consequently disconnected. In this work (with reference to the Raptor-SK coupling), calculations were made to select the diameter of the shear pins depending on the value of the limit torque M_{gr} . In order to assess the correctness of the selection of pins used in the coupling mechanism, experimental tests were carried out using a testing machine. A comparison was made between the design calculations of the shear pins and the results of research on a test bench.

Key words: *safety couplings, selection of shear pins, strength tests of pins*

1. INTRODUCTION

Couplings are used in virtually every machine drive system. In many cases of modern construction, they fulfill not only the role of a shaft connector through which torque is transmitted to the subsequent components of the drive system but also additional functions. These functions can be, for example, compensation of misalignments of the connected shafts' setting (self-adjusting couplings), reduction of dynamic loads (flexible couplings), disconnection of shafts during their operation (controlled, self-acting, centrifugal couplings), transmission of torque in only one direction (one-way coupling), and many others.

Machine drive systems are often exposed to the occurrence of overloads and transient states (e.g., start-ups, blockages). The purpose of protecting its assemblies is to use safety couplings (also called overload couplings). The operation of these couplings is based primarily on two solutions [1]. In the first one,

the coupling members are completely disengaged under the influence of the boundary torque value. Then, a properly selected connector (usually in the form of a pin) is destroyed – it is the weakest supporting element in the coupling and, thus, in the whole drive system. The second solution is to use a coupling with a mechanism to limit the value of the transferred torque to a safe value. This group of couplings includes couplings with a friction coupling, for example, where there is a relative slip on the friction linings between the active and passive coupling members during overloading (e.g., SafeSet couplings from Voith [2]).

The considered Raptor-SK coupling with shear pins combines the characteristics of a torsionally flexible coupling and a safety coupling.

The purpose of coupling protection for the machine's drive system components against overloads is most importantly to disconnect the drive at a strictly determined torque value with the highest accuracy of its value preservation.

2. DESIGN OF RAPTOR-SK COUPLING

Dodge®Raptor series couplings belong to non-separable, mechanical, and torsionally flexible couplings with the possibility of compensating for the misalignment of a shaft (Fig. 1).



Fig. 1. General view of Dodge®Raptor coupling [3]

The Raptor coupling is characterized above all by the original design of an elastic insert made of natural rubber. According to the manufacturer, applied patented technology called WingLock [4] optimizing the construction of the elastic insert provides high short-term and fatigue strength and long life as compared to other designs of this type of coupling.

Dodge®Raptor couplings are produced in many variants; e.g., the coupling may be combined with a disc or a brake drum and is equipped with a torsion angle limiter between the coupling members.

The subject coupling with the designation Raptor SK (Fig. 2) has been equipped with an additional member in which “fuses” in the form of pins (or a pin) subjected to shearing are installed at a given value of transferred torque. This study focuses on the coupling drive overload protection function.

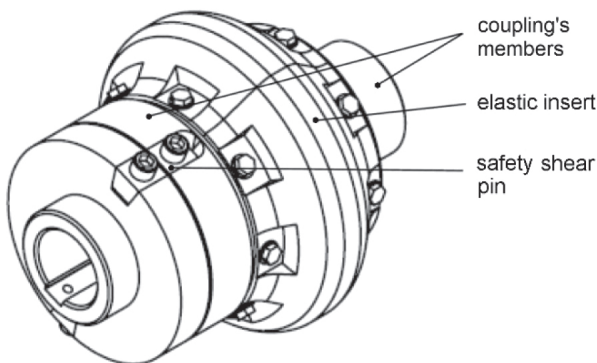

Fig. 2. RAPTOR-SK flexible coupling with safety shear pins

3. SELECTION OF SAFETY PINS USED IN RAPTOR-SK COUPLING

When designing a machine drive system, the designer usually selects a coupling from the manufacturer's catalogs; sometimes, it must be specially designed for a given machine [5]. The coupling is selected by calculating the M_o torque, taking into account the nominal M_n torque that is transmitted by the connected shafts and the overload values specified by factor k :

$$M_o = M_n \cdot k \quad (1)$$

where:

- M_o – torque [Nm],
- M_n – nominal torque [Nm],
- k – overload factor.

In couplings performing the function of the drive system's protection against overload, the values of design boundary moment M_{gro} causing the pin to be cut (or pins, depending on their number) should additionally be determined. The limit torque at which the coupling members will be disconnected is determined by the coupling manufacturer with the machine drive system designer.

Knowing the values of design limit M_{gro} for calculating the diameter of pin d_o , the following formula is applied:

$$d_o = 1.6 \sqrt{\frac{M_{gro}}{D_p n R_t}} \quad (2)$$

where:

- d_o – diameter of the pin [m],
- D_p – pitch diameter of the pin arrangement (pins) [m],
- n – number of pin,
- R_t – shear strength for the pin material [MPa].

For the Raptor-SK coupling with the designation/size of E80 (for which the pitch diameter of the pins is $D_p = 241$ mm), calculations have been carried out to select the diameter of the shear pins depending on design limit torque M_{gro} . The calculations were carried out at the design M_{gro} limit values of 3800, 15,000 and 34,000 Nm for securing pins made of steel for heat treatment and hardening. The calculations were carried out for a coupling with one pin. Table 1 presents the results of the calculations.

Table 1
Results of calculations for safety pins

Calculation value boundary torque M_{gro} [Nm]	Computational diameter of pin d_o [mm]
3800	5
15,000	10
34,000	15

For the assumed values of the M_{gro} limit torque and the accepted strength data of the steel used, the calculated diameters for the pins are 5 mm, 10 mm, and 15 mm, respectively.

After performing strength calculations specifying design diameter d_o , an experimental verification of the obtained results was made for pins with the above-mentioned diameters.

4. EXPERIMENTAL TESTS OF PROTECTION PINS USED IN RAPTOR-SK COUPLING

The use of “fuses” – shear pins – in the coupling limits the value of the transferred torque to a safe value, beyond which the fuses are cut off, consequently, the drive is disconnected. For the purpose of an experimental verification of the structural calculations carried out, shear strength tests were carried out on a test stand (Fig. 3).

The basic element of the test stand is a strength machine (1) on which a specialized shear-clamping device (2) has been installed (Fig. 4). A safety shear pin (3) was secured in the instrument. During the tests using a force transducer (4), the value of force F was measured that is exerted by the testing machine for the device (2) (limit value of this force corresponds to the shear force F_t pin) and by the sensor (5), the value of the working displacement l of the testing machine. Measurement signals are sent to the digital A/C measuring module (6), which conditions, measures, and archives both measuring signals with a visualization on a computer screen (7). The F load applied during the tests was static and increased with a fixed speed.

In order to model the process of the “clean” shearing of the pin and its unambiguous fixing and mounting on the station, a specialized original shear-fixing device was designed and made (Fig. 4).

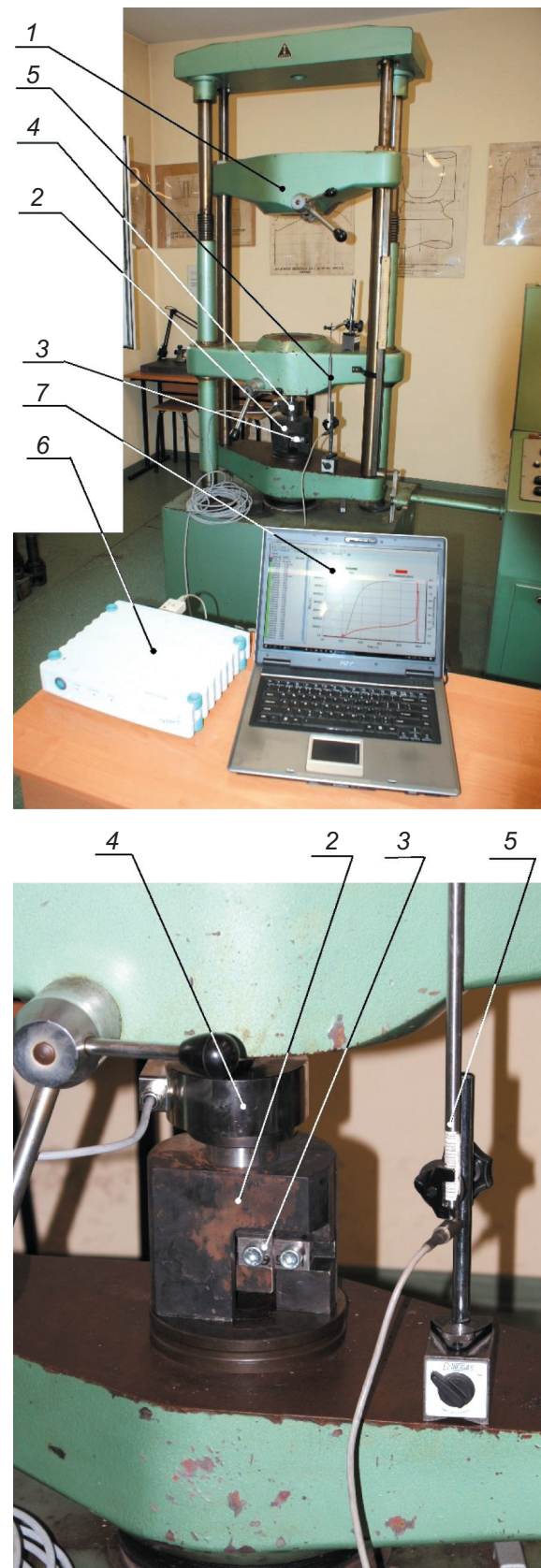

Fig. 3. View of test stand for testing protection pins, where: 1 – strength machine, 2 – fixing and shearing device, 3 – shear bolt, 4 – force transducer, 5 – displacement sensor, 6 – digital A/C measuring module, 7 – computer

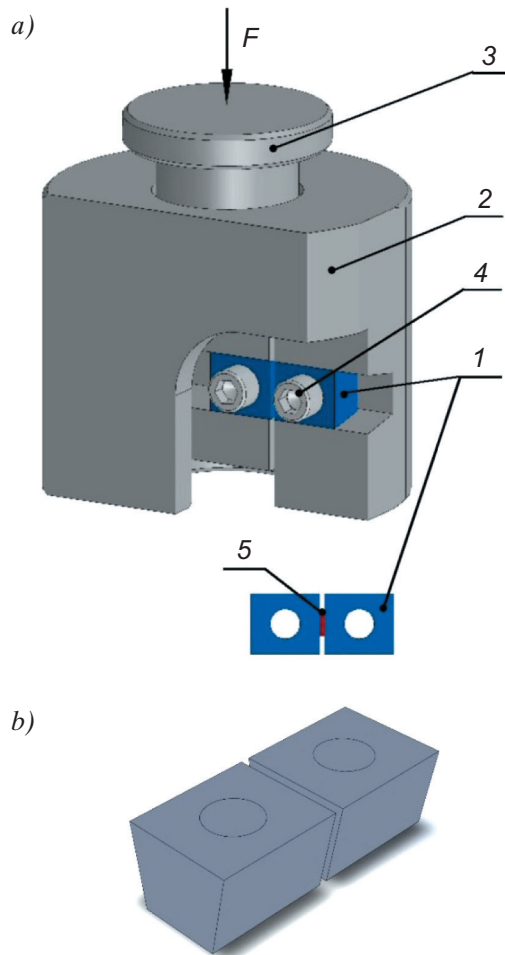

Fig. 4. Shear-cutting device used to shear pins: a) view of device; b) view of shear pin, where: 1 – shear pin, 2 – device base (fixed support), 3 – sliding piston, 4 – fixing screws, 5 – shear part of pin, F – force loading device

The device consists of a fixed casing (base) (2) to which one side of the pin (1) and a movable piston (3) are fastened by means of a screw (4) to which the other side of the pin is attached. During the tests, the increasing load F of the piston (3) to limit value F_t , causes the piston to displace and, consequently, shear the test pin. The course of changes in force value F , and displacement l is measured and recorded using the measuring equipment.

The tests were carried out for pins with diameter d made of steel for thermal tempering and hardening (Fig. 4) of 5 mm, 10 mm, and 15 mm. The pins were hardened throughout. Figure 5a shows the view of the security pin prior to testing, and 5b shows it after its cutting.

Table 2 presents the values of shear force F_t at which a pin with a given diameter d was cut as well as the value of corresponding boundary moment M_{gr}

for coupling E80. Figure 6 presents an example of the measurement result of the pin measurement with the designation of p7 using a digital measuring module.

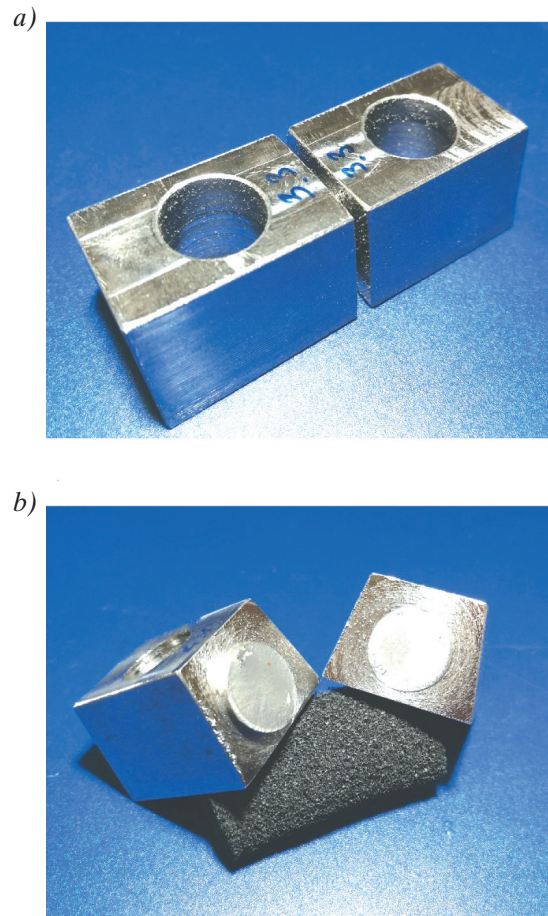

Fig. 5. View of shear pin: a) before test; b) after cutting pin

Table 2
Comparison of results from experimental tests of shearing pins

Pin's marking	Diameter d [mm]	Average value of shear force F_t [N]	Average value of boundary moment M_{gr} [Nm]
p1–p3	5	17,750	4277
p4–p6	10	66,954	16,136
p7–p9	15	147,962	35,659

In Figure 7, the values of boundary moment M_{gr} obtained from the conversion of the shear force F_t pin and pitch diameter D_p (some simplification) are presented in the form of a bar graph. For pins with a diameter of 5 mm, the highest torque M_{grmax} at which the coupling was disengaged was 4497 Nm. On the other hand, the smallest torque value M_{grmin} was 4008 Nm.

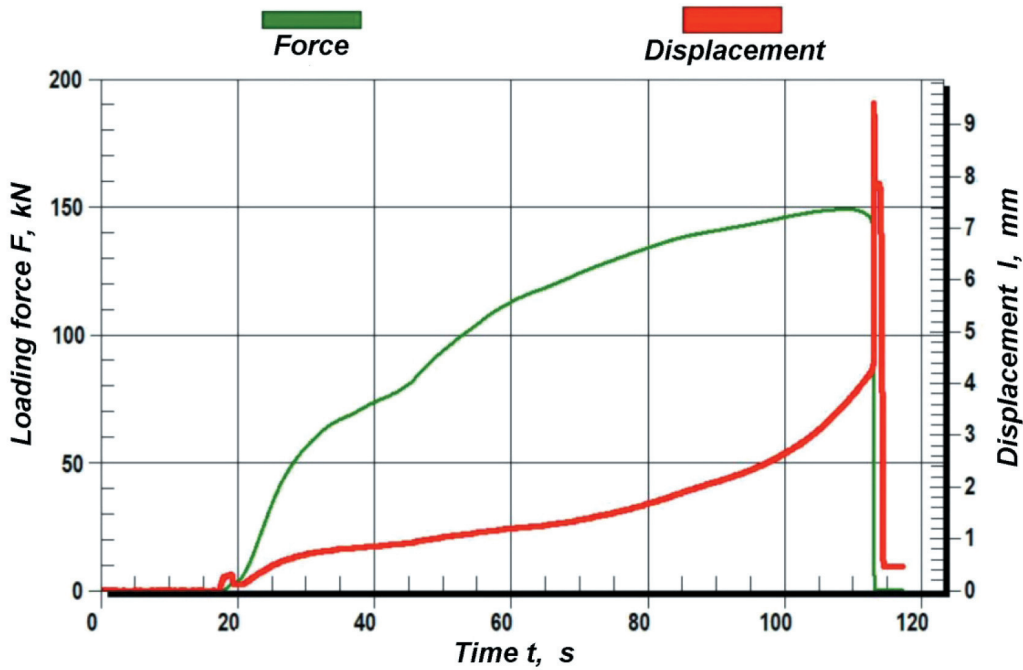

Fig. 6. Example of measurement result measured for p7 pin

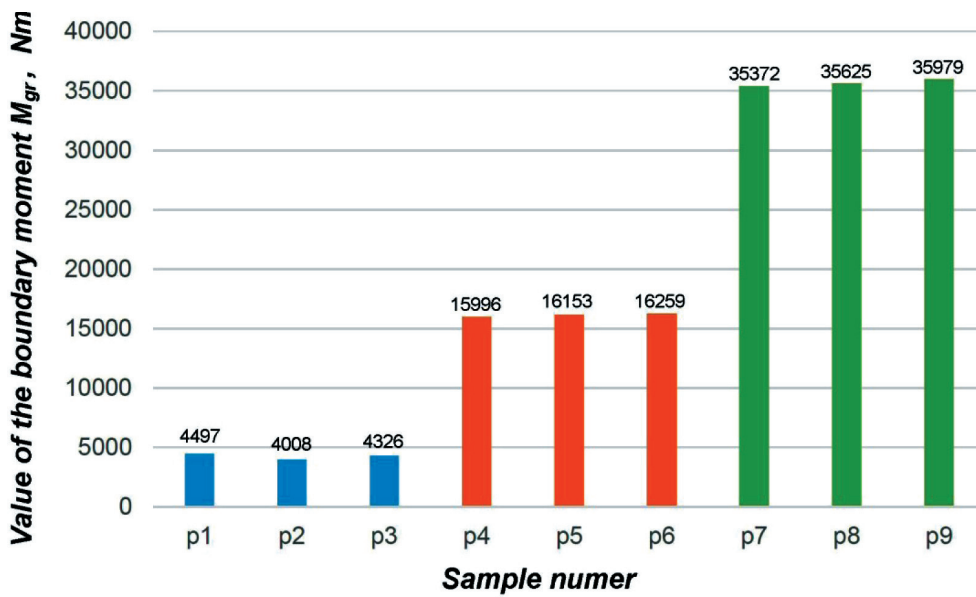

Fig. 7. Limit values for tested shear pins, where p1–p3 = pins with diameter of 5 mm, p4–p6 = pins with diameter of 10 mm, and p7–p9 = pins with diameter of 15 mm

Therefore, coefficient γ_5 , specifying the accuracy of the load limit for the considered coupling is calculated from formula [1].

$$\gamma_5 = \frac{M_{gr \max}}{M_{gr \min}} = \frac{4497}{4008} = 1.12 \tag{3}$$

Similarly, coefficient γ_5 was determined for the remaining diameters of the protection pins. The calculated values of coefficient γ_5 are shown in Table 3.

Table 3

Values of γ_5 factor determining accuracy limits of coupling load torque

Pin's diameter d [mm]	5	10	15
Value of γ_5 factor	1.12	1.02	1.02

For couplings with shear pins in accordance with [1], the value of the coupling disengagement accuracy coefficient should be within a range of 1.1–1.4.

Therefore, on the basis of the test results, it can be concluded that all of the safety pins have been made correctly, both in terms of the mechanical processing and pins with diameters of 10 mm and 15 mm meet the allowance in accordance to [1].

Figure 8 presents a comparison of the calculated values of the M_{gro} boundary moment with the averaged values of the boundary moment M_{gr} (according to Tab. 2) obtained from the tests.

As it is easy to see, the values of the calculated boundary torque M_{gr} obtained on the basis of the ex-

perimental tests (pin cutting) are greater than the values of the M_{gro} boundary moment obtained from the calculations. For pins with a diameter of 5 mm, the difference was about 12%, for pins with a diameter of 10 mm – 7%, and for the 15 mm pins – 5%. The difference in the boundary moment values between the results obtained from the calculations and the results from experimental tests may result, for example, from the value of allowable shear stress k_t and the coefficient of proportionality k_o in the strength calculations accepted for the calculations.

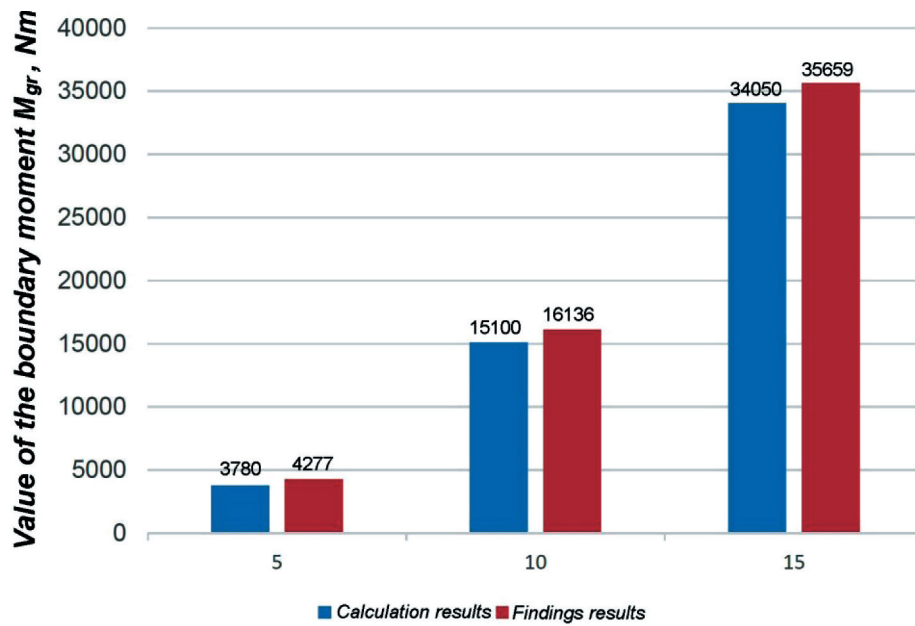

Fig. 8. Comparison of value of calculated boundary moment with average value for tested samples

5. SUMMARY

The simplest protection of a drive system's components against overloading are safety couplings with break-away switches. In the case of the Raptor-SK coupling, the connectors have the shape of a cylindrical stud with two mounting surfaces.

The calculations of the diameter of the shear pins for specific values of limit moments performed in the work and experimental tests carried out for their three different diameters showed the following:

- there is a difference in the value of boundary moment M_{gr} between the calculated values (M_{gro}) and those obtained from the research (M_{gr}) (Fig. 8),
- higher values of boundary moment M_{gr} occur for results obtained from the experimental tests (Fig. 8),

- on the basis of the experimental tests, similar values of boundary moment M_{gr} were obtained for each pin diameter (Fig. 7); the indicator determining the accuracy of load limit γ_5 was a maximum of 1.12 for the tested diameter of 5 mm (Tab. 3).

From the analysis carried out in the work, it can be concluded that, for the calculated shear pin diameters after conducting experimental tests, higher boundary moment values were obtained than assumed in the theoretical calculations. The greater the difference, the smaller the diameter of the locking pin. Ultimately, this will cause the coupling protection to operate at a higher boundary moment than expected (resulting from the calculation).

Summarizing all of the analyses carried out at work, it can be stated that, the choice of pin diameter cannot be based only on theoretical calculations; the realization of check tests should be considered as well, especially when using these couplings (with safety pins) in machines of high operational importance.

References

- [1] Dietrich M. (red.): *Podstawy konstrukcji maszyn*, t. 3, Wydawnictwa Naukowo-Techniczne, Warszawa 1999.
- [2] <https://voith.com/corp-en/torque-limiting-couplings.html> [20.05.2018].
- [3] www.fena.pl [20.05.2018].
- [4] <https://www.baldor.com/brands/baldordodge/products/couplings-clutches-brakes/elastomeric-couplings/raptor> [20.05.2018].
- [5] Skoć A., Spalek J., Markusik S.: *Podstawy konstrukcji maszyn*, t. 2, Wydawnictwa Naukowo-Techniczne, Warszawa 2008.

KRZYSZTOF FILIPOWICZ, D.Sc., Eng.

MARIUSZ KUCZAJ, Ph.D., Eng.

*Department of Mining Mechanization
and Robotization*

Faculty of Mining and Geology

Silesian University of Technology

ul. Akademicka 2, 44-100 Gliwice,

Poland

{krzysztof.filipowicz, mariusz.kuczaj}@polsl.pl

PAWEŁ GRUSZKA, M.Sc., Eng.

Fabryka Elementów Napędowych FENA Sp. z o.o.

ul. E. Imieli 47, 41-605 Świętochłowice,

Poland

dz.techniczny@fena.pl