

PARALLEL PERSPECTIVE - INNOVATIVE CONSTRUCTION METHOD OF ORTHOGRAPHIC AXONOMETRIES

Andrzej Zdziarski¹⁾ Renata A. Górska²⁾

Cracow University of Technology (CUT)
Division of Descriptive Geometry, Technical Drawing & Engineering Graphics, A-43
ul. Warszawska 24, 31-155 Kraków, Poland
email: ¹⁾ azdziarski@interia.pl, ²⁾ rgorska@pk.edu.pl

Abstract. Described here construction of an axonometric view of any three-dimensional object has been developed analogically to the method that is commonly used in perspective projection. It is possible to intentionally adopt two parameters of axonometric drawing so that we receive the required image of a structure. These two parameters to be selected are: the trace s_1 of the axonometric picture and the height of point O_n . Some discussion on possible positions of the point O_n has been conducted and also a few exemplary drawings have been presented in the publication.

Keywords: Descriptive geometry, axonometric projection, visualization

Introduction

Basic feature of perspective representation of any three dimensional (3D) object is that the parallel lines creating its parallel edges converge at a single point which is called a vanishing point. Any line \mathbf{a} will be represented in the perspective projection by the line \mathbf{a}^s which will go through two points: \mathbf{T}_a – the trace of the line \mathbf{a} in the picture plane and the vanishing point \mathbf{V}_a which is the image of a point at infinity lying on the line \mathbf{a} . In this paper we will present the new method of creation of various axonometric images (=pictorials), where the analogy to the perspective projection will be considered and the parameters assigned to alternative solutions will be discussed.

According to the sources provided in [2] “**axonometric projection** is a type of parallel projection used to create a pictorial drawing of an object, where the object is rotated along one or more of its axes relative to the plane of projection”. **Axonometric projection**, or as it is also called a **parallel perspective** [1], has provided a fantastic tool for architects and artists and has become popular since the modernist architects from Bauhaus (e.g. Theo van Doesburg) started to use axonometric projections in their design projects.

Polish standards ([5], [6], [7]) which are currently in force distinguish three types of axonometric projections: **isometric**, **dimetric**, and **trimetric** while only **isometric projection** has been defined as an **orthographic projection**. The two other types of axonometric projections (**dimetric** and **trimetric**) have been classified in [7] as **oblique** projection methods. According to classification provided by Otto et al. in [3] within the group of **orthographic projections** one can distinguish anisometric, dimetric and isometric types of projection (dependent on the differences between foreshortening factors along the principal axonometric axes) and also similar distinction has been provided for oblique axonometric projection. It is worth mentioning that in the standard [7] a new term within oblique projection type has been introduced for the “planometric” (*aksonometria planometryczna, Pl.*) representation which replaced the notion of “Perspektywa wojskowa”(Pl) which has been used up-to-date by Polish geometers [3]. In German literature ([4] p.70) the notion of

“Grundrissaxonometrie”, “Vogelprojektion”, “Militärprojektion” or “Planometrische Projektion” can be found for this type of oblique axonometric projection.

1 Initial parameters' specification: co-ordinate system, picture plane and direction of observation

In this paper we will focus only on the case of orthographic axonometric projection. Designations used in the drawings will comply with those used by Otto et al ([3] p.155).

1.1 Orthographic views of a 3D structure

We will describe the method of **orthographic axonometric view** construction in which we start from the given **two** (or **three**) **orthographic views** represented in the European method (Fig.1). We adopt a Cartesian coordinate system (**Oxyz**) with the **z** axis parallel to the vertical edges of a structure, while the principal planes of the **Oxyz** system are parallel to the faces of our building.

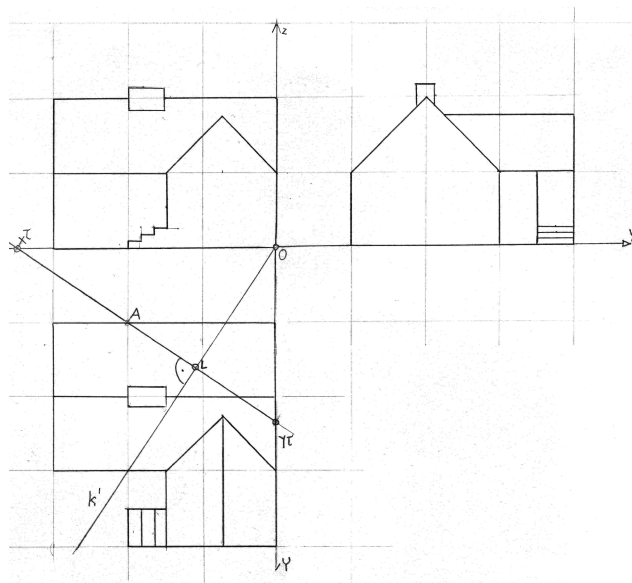

Figure 1: Principal orthographic views of a 3D structure (European method)

1.2. Adopting an axonometric picture plane - traditional approach

Let us adopt an **axonometric picture plane** π_a which will be oblique in reference to the Cartesian Coordinate System **Oxyz** (Fig.2). The picture plane π_a is perpendicular to the assumed vector **k**, which represents the **line of sight** (LOS). After Otto et al. ([3] p.155) we will use the labels **S_x**, **S_y** and **S_z** for the piercing points of the axes **x**, **y** and **z** respectively with the plane π_a . The sides of the triangle that are the **traces** of the **picture plane** π_a on the principal planes of Cartesian coordinate system will be respectively labeled with **s₁**, **s₂**, **s₃** (Fig.2). For the case of orthographic projection the triangle of traces **S_xS_yS_z** is always an **acute-angled triangle** ([3] p.150). The heights of the triangle **S_xS_yS_z** create the axonometric axes **xⁿ**, **yⁿ**, **zⁿ**. From the fact that the LOS is perpendicular to the picture plane π_a and the origin **O** will be projected at right angle into the plane π_a we conclude that axonometric axis **zⁿ** will be passing through the point “**T**” that lies at the intersection of two lines: the trace **s₁** and the line which is **perpendicular to the trace s₁** and passing through the origin **O** (Fig.2).

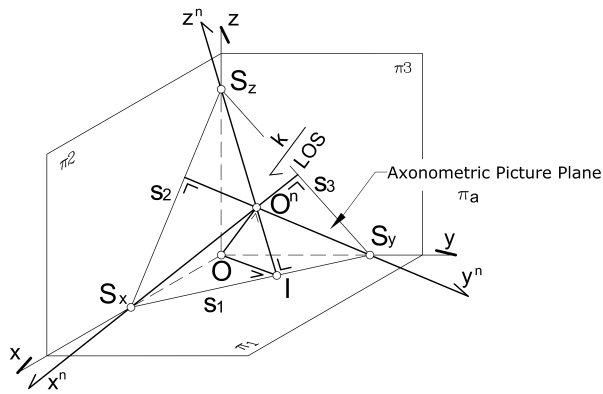

Figure 2: Axonometric picture plane π_a

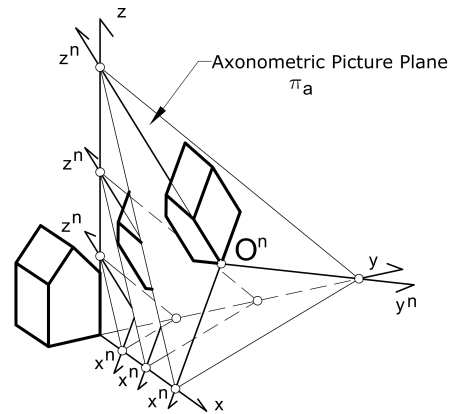

Figure 3: Parallel translation of the picture plane π_a
 (picture after Leopold ([4], p.201))

Axonometric picture plane π_a can be positioned at any distance from the origin O of the Cartesian $Oxyz$ system. Parallel translation of the picture plane π_a **does not change the size of the axonometric view** as the lines of sight create a bundle of **parallel rays** which intersect the family of parallel axonometric picture planes π_a^i and produce congruent figures (Fig.3 after Leopold, [4] p.201).

2 What is new in the described here method? Traditional and new methods used to adopt the LOS

2.1 Traditional method

Typical descriptive geometry textbooks ([3], [4]) provide instruction on axonometric views construction. First, we optionally choose any acute-angled triangle, second we determine the three heights of the triangle and finally we conclude that the heights of the triangle create the axonometric axes x^n , y^n and z^n . The method does not explain any relation between the assumed direction of observation k (LOS) and the expected view outcome. Traditionally, **two parameters** of the direction of observation k (LOS) have to be defined: its top view k' and its front view k'' (Fig.4). The first parameter k' defines from which “side” we are looking at the building (the options are: from the **left-hand side**, from the **right-hand side**, from the **front**, and from the **back side**) while the k'' parameter defines the slope angle of the vector k of our observation in reference to the base plane Oxy (in Fig.4: k' and k'' are orthographic views of the vector k).

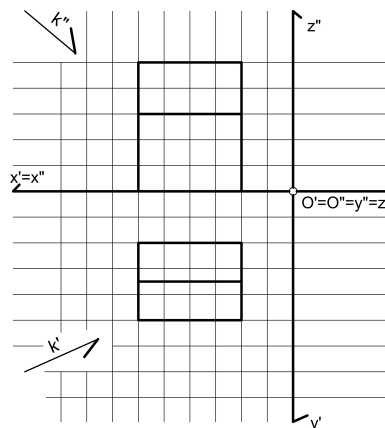

Figure 4: Adopting the Cartesian coordination system and direction k

2.2 Specifying basic parameters in a new method

Innovation of the described method lies in the fact that we are able to intuitively specify two parameters of axonometric view (vector \mathbf{k}' and the position of point \mathbf{O}^n) in such a way that we will receive such an image of a structure that we want to get. Two parameters will be chosen:

- 1) direction \mathbf{k}' that defines which side we want to observe the object from (e.g. from the left-hand side, from the right-hand side, from the front or from the back),
- 2) the height of the point \mathbf{O}^n which decides what is the inclination of the direction of observation \mathbf{k} in reference to the object.

Let us notice that the vector \mathbf{k}'' is **not** specified. The inclination of the vector \mathbf{k} will be defined by the position of point \mathbf{O}^n . Possible variations of the point \mathbf{O}^n position have been analyzed in paragraph 4 of this publication.

3 Axonometric view construction

3.1 Selection of the position of the trace s_1

The trace s_1 can be chosen at any distance from the building but always **perpendicular to the direction \mathbf{k}'** . Preferred position will be chosen when one vertex, let's say point \mathbf{A} , of the building's base belongs to it (Fig.5). The trace s_1 intersects respectively with the axes \mathbf{x}' and \mathbf{y}' at points \mathbf{S}_x and \mathbf{S}_y . Let us orthogonally project the origin \mathbf{O} onto s_1 in the direction \mathbf{k}' . We will label the point of intersection with \mathbf{I} and the axis \mathbf{z}^n will start vertically from this point.

In order to construct an axonometric view of a building a **grid of lines** in the base plane of a building will be chosen (Figs.5-9). Each edge of the building's base will be a line determined with its **trace on the line s_1 and the point at infinity**. The sides of our building are respectively parallel to the axes \mathbf{x} and \mathbf{y} .

3.2 Transferring distances between an orthographic and axonometric views

On any horizontal line we measure **the distances** between points: \mathbf{S}_x , \mathbf{I} and \mathbf{S}_y and we respectively label these points. In Fig.5 the distance between \mathbf{S}_x and \mathbf{I} equals \mathbf{a} . The vertical axis \mathbf{z}^n starts at point \mathbf{I} . We select point \mathbf{O}^n at any height of the \mathbf{z}^n but within the semicircle with the diameter $\mathbf{S}_x\mathbf{S}_y$. Points \mathbf{O}^n and \mathbf{S}_x determine together the axis \mathbf{x}^n , while \mathbf{O}^n and \mathbf{S}_y make together the axis \mathbf{y}^n . The missing sides s_2 and s_3 of the triangle of traces can easily be added by drawing perpendiculars to lines \mathbf{x}^n and \mathbf{y}^n through points \mathbf{S}_y and \mathbf{S}_x , respectively.

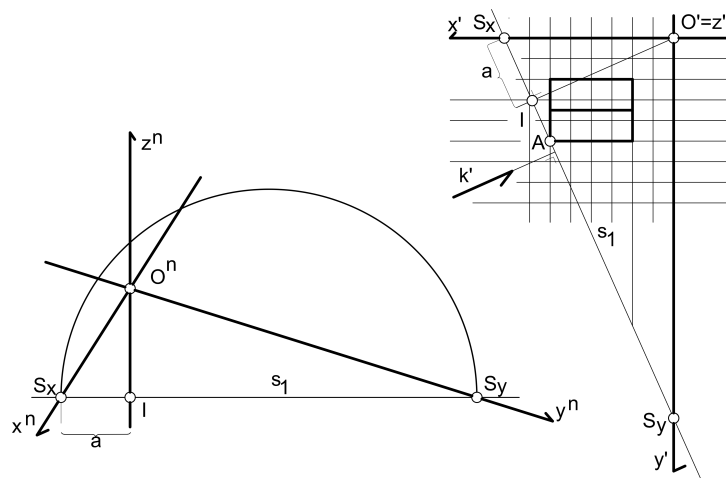

Figure 5: Direction of observation \mathbf{k} chosen from the left-hand side. Plan view of the situation and the axonometric axes

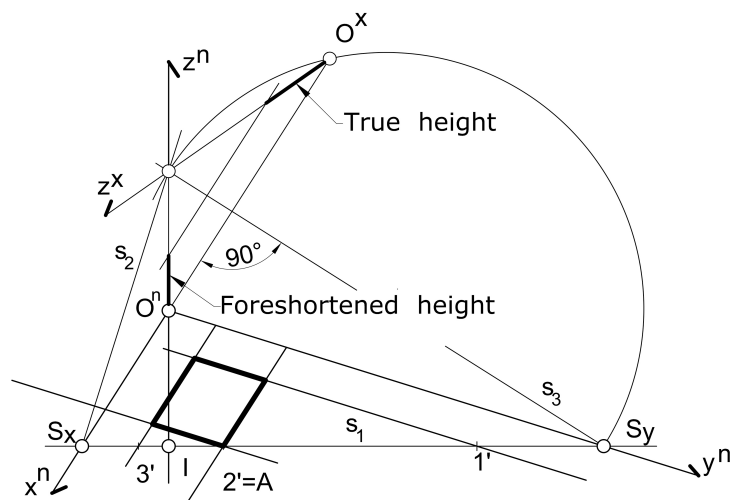

Figure 8: Foreshortening the heights of vertical edges

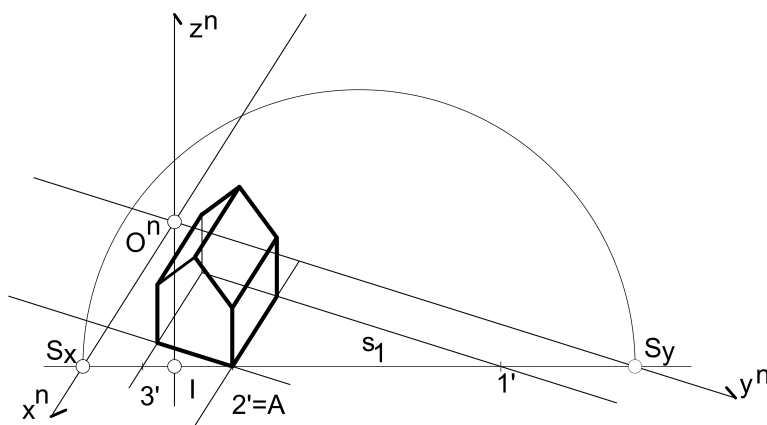

Figure 9: Axonometric view of a building

4 Determining the position of point O^n

Position of the center O^n has specific constraints. As the point O^n is the orthocenter of the acute-angled triangle of traces $S_x S_y S_z$ it must be chosen within the semicircle based on the trace $S_x S_y$. Let us discuss various positions of point O^n dependent on the inclination of the direction of observation \mathbf{k} .

In Fig.10 we have adopted a family of picture planes π_a^i ($\pi_a^1, \pi_a^2, \pi_a^3, \pi_a^4, \pi_a^5, \dots$), all passing through a common line $S_x S_y$. Subsequent positions of the picture planes of the family (π_a^i) have been obtained by the picture plane rotation around the trace $S_x S_y$. Directions of observation create a family of directions (\mathbf{k}_i) which are always perpendicular to the respective picture planes (π_a^i). The picture plane π_a^1 is perpendicular to the direction \mathbf{k}_1 , the picture plane π_a^2 is perpendicular to the direction \mathbf{k}_2 , the picture plane π_a^3 is perpendicular to the direction \mathbf{k}_3, \dots etc. In Fig.10b we can see the picture planes π_a^i as the edge views. The points O_i^n are the images of the origin O in orthographic projection. We construct each of the points O_i^n as an orthographic projection of the origin O onto the picture plane π_a^i in the direction \mathbf{k}_i (Fig.10b).

The triangle of traces $S_x S_y S_z$ gets changed for various positions of \mathbf{k}_i . The trace S_z can be either a real point or a point at infinity $S_z^{1\infty}$. In Fig.10 we can see that the traces $S_z^2, S_z^3,$

S_z^4 , and S_z^5 for the inclined directions k_2, k_3, k_4, k_5 are the real points, while the trace $S_z^{1\infty}$ lies at infinity and the position of the picture plane π_a^1 is vertical, while the corresponding direction k_1 is horizontal. Point O_1^n belongs to the trace S_xS_y and coincides with the point **I**. In this case we obtain a front view of a 3D object.

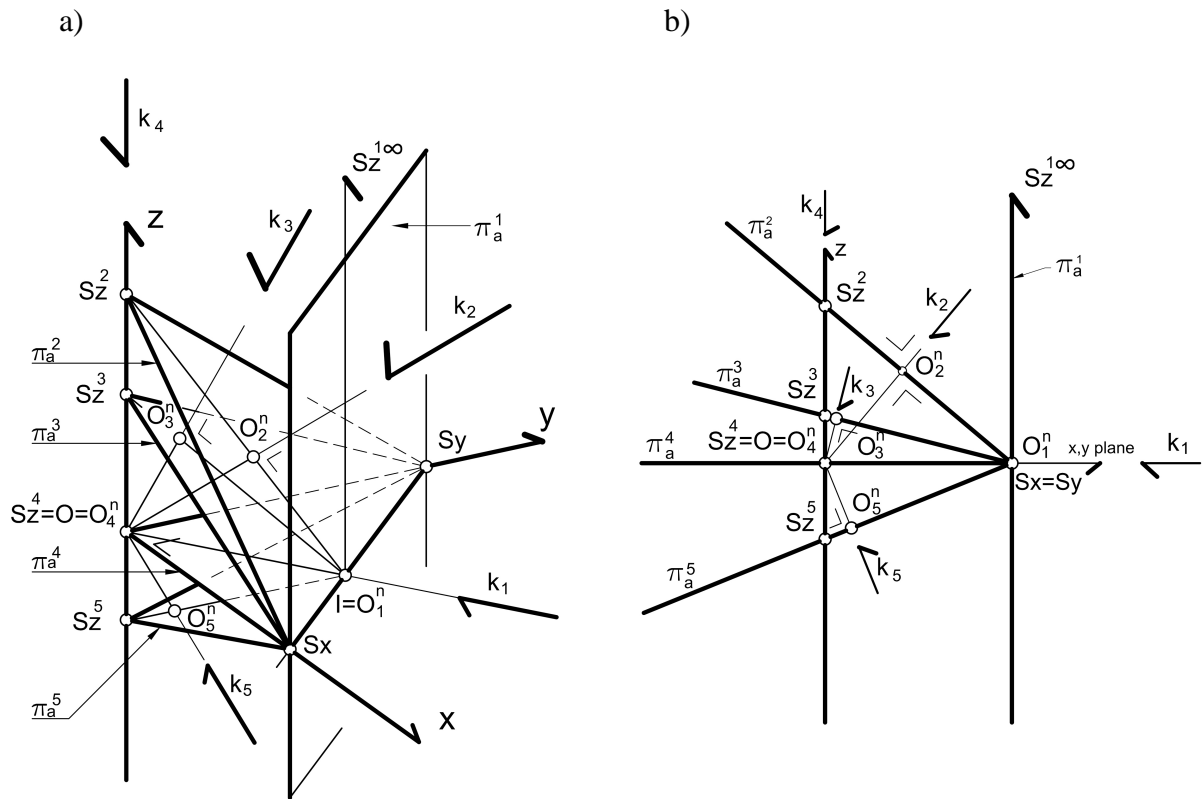

Figure 10: Relation between the direction of observation k and the position of point O^n : a) 3D view, b) edge view of picture planes

Analysis of Fig.10 leads to the conclusion that the more oblique **direction k** the larger distance between points **I** and O_i^n . The limiting positions of the direction k are:

- horizontal direction $k_1 \parallel Oxy$ - we obtain the front view
- vertical direction $k_4 \perp Oxy$ - we obtain the **top view** of a structure

Figure 11 illustrates how can we adopt the position of point O^n . Once we have transferred the trace S_xS_y together with the point **I** we need to construct a circle of a diameter S_xS_y and to draw the vertical axis z^n through the point **I**. Point O^n can be freely chosen on the z^n but within the circle. In Fig.11, the labels for designation of points O_i^n have been used analogically to the positions of direction k as they were used in Fig.10. Specifically we have:

- Point $O_1^n=I$ - a horizontal direction k ; we obtain the elevation view;
- Points O_2^n, O_3^n above the trace S_xS_y - inclined direction k ; we obtain the isometric view of a structure as observed from above the object; this picture can be compared either to the bird's eye view or to the human's eye view in perspective projection; let us notice that the closer point O_i^n to the circle, the more steep direction of observation k ;
- Point O_4^n - a vertical direction k ; we obtain the top view;

- Point O_5^n below the trace S_xS_y - inclined direction k ; we obtain the isometric view of a structure as observed from below the Oxy plane; this picture can be compared to the worm's eye view in perspective projection,
- Point O_6^n - a **vertical** direction k but observation from the bottom; we obtain the **bottom view** (Fig.11).

Now the axonometric axes can be drawn. The axis x_i^n goes through two points: O_i^n and S_x , while the axis y_i^n goes through two points: O_i^n and S_y . Direction of the axonometric axis always determines the point O_i^n and point S_x for the axis x^n (or S_y for the axis y^n).

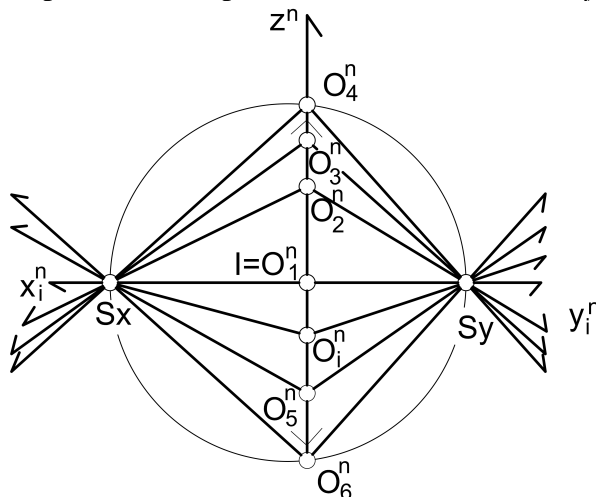

Figure 11: Analysis of the possible positions of the point O^n

5 Using a modular grid for parallel perspective construction

In this text a modular grid was used to construct the axonometric view of a house. However, it is not obligatory to use such a grid. Similarly to the central projection case, any base of a three-dimensional (3D) structure can be constructed with the use of the method described here. Any line in the plane Oxy will be determined with two points: the trace which will be determined as a piercing point with the picture plane π_a and the vanishing point which for this type of projection is a point lying at infinity. Fig.13 shows the case of construction with a **modular grid** in the plan view application. Fig.14 shows an example with a **non-modular** grid application.

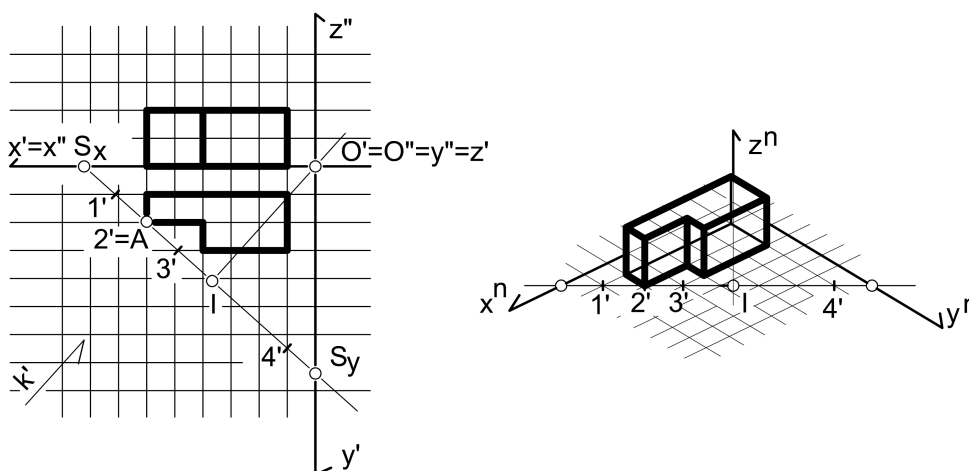

Figure 12: Axonometric view of the house – Regular grid of the base

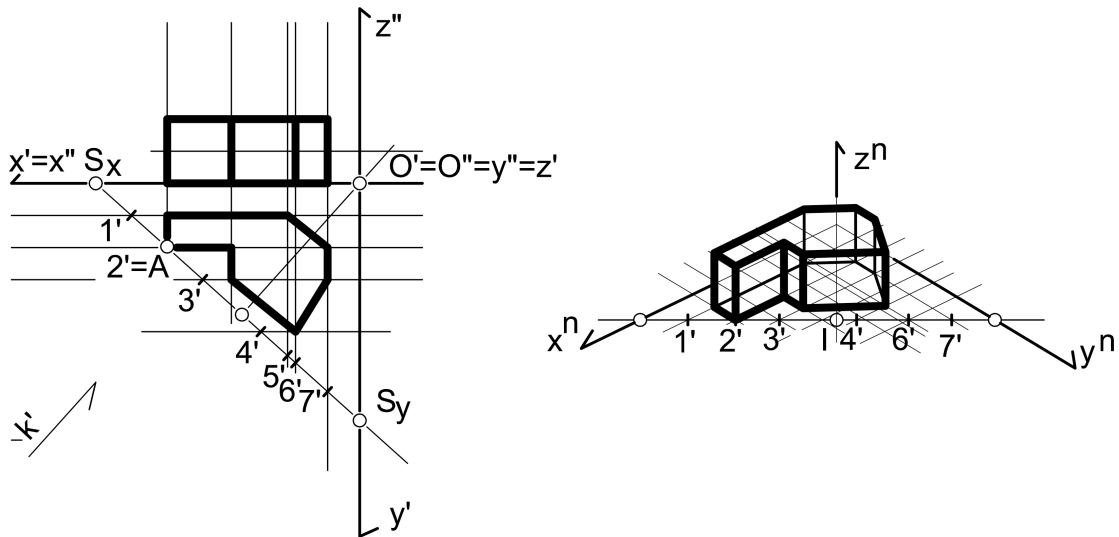

Figure 13: Axonometric view of the house – Irregular grid of the base

6 Conclusion

The method presented here is easy and intuitive. Hand-made drawings presented here (Fig.14 and Fig.15) have been created by the students of Architecture within the course of Descriptive Geometry. Fig.12 shows the axonometric view of a family house which has been founded on the hill as observed from its bottom. This view can be compared to a "worm's eye view" construction in central projection. Figure13 shows a pictorial of the same house as observed from the "bird eye" view. The method has been taught at our university for many years now but has never been put into edition. Obviously, the novelty of here described procedures does not lie in description of axonometric representation but in description of the new approach and the new construction methodology. Strong analogies have been found between axonometric and perspective views' construction methods.

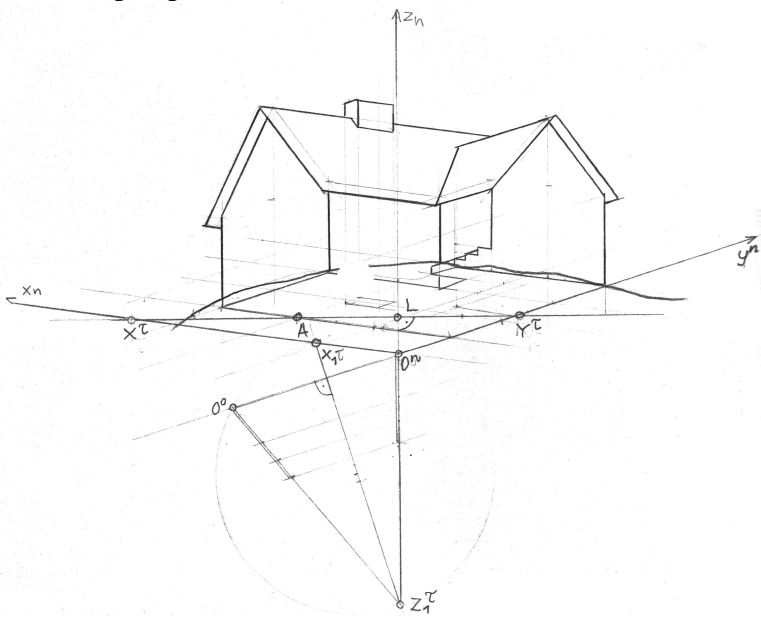

Figure 14: Axonometric view of a house presented in Fig.1 – Worm's eye view: observation from "below" the plane Oxy - handmade drawing

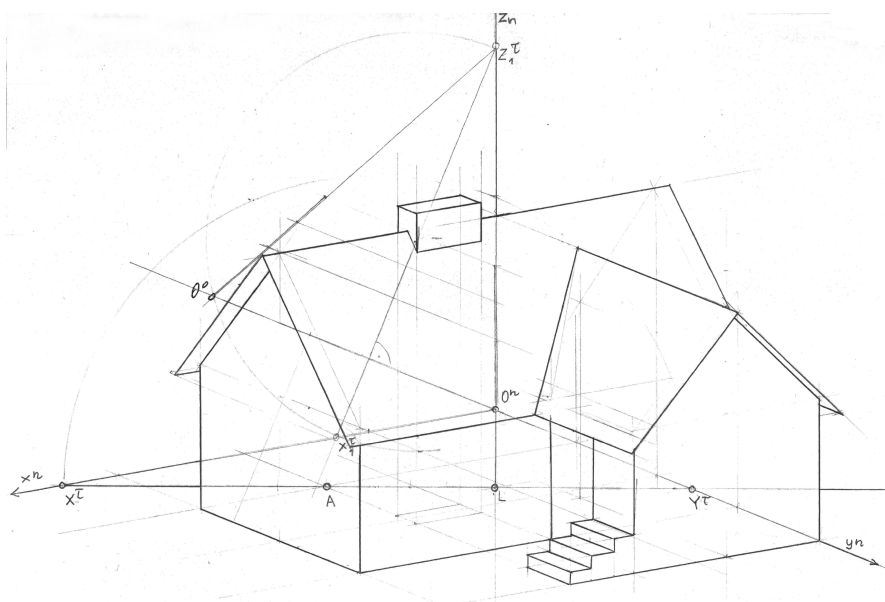

Figure 15: Axonometric view of a house from Figure 1 - observation from above" the plane Oxy: handmade drawing

References

- [1] Bartel K.: *Perspektywa malarska*. PWN, Warszawa, 1958.
- [2] Bertoline G.R. et al.: *Technical Graphics Communication*. McGraw-Hill Professional, 2002. ISBN 0-07-365598-8, p.330.
- [3] Otto F., Otto E.: *Podręcznik geometrii wykreślnej*. PWN, Warszawa, 1975.
- [4] Leopold C.: *Geometrische Grundlagen der Architekturdarstellung*. Kohlhammer, 1999, p.199, 201.
- [5] PN ISO 128-30:2006 – Rysunek techniczny – Zasady ogólne przedstawiania. Część 30: Wymagania podstawowe dotyczące rzutów.
- [6] PN EN ISO 5456: 2002 Rysunek techniczny – Metody rzutowania – Część 1: Postanowienia ogólne.
- [7] PN EN ISO 5456: 2002 Rysunek techniczny – Metody rzutowania – Część 3: Rzutowanie aksonometryczne.
- [8] <http://www.arch.pg.gda.pl/> - strona Wydziału Architektury, Katedra Sztuk Wizualnych.

PERSPEKTYWA RÓWNOLEGLA - INNOWACYJNA METODA KONSTRUOWANIA AKSONOMETRII PROSTOKĄTNEJ

Istotną cechą odwzorowania perspektywicznego na tło płaszczyznowe jest to, iż obraz dowolnej prostej jest prostą wyznaczoną przez dwa charakterystyczne punkty: jednym z nich jest ślad tłowy, a drugim jest ślad zbiegu, czyli obraz punktu niewłaściwego tej prostej. Celem niniejszego opracowania jest analiza odwzorowania jakim jest aksonometria prostokątna i zastosowania do jej konstrukcji analogicznego rozumowania do tego, jakie stosujemy w odniesieniu do rzutu środkowego. Obraz prostej leżącej w płaszczyźnie podstawy obiektu trójwymiarowego będzie kształtowany jako prosta wyznaczona przez dwa punkty: ślad tłowy na rzutni aksonometrycznej w przecięciu się ze śladem poziomym tła aksonometrycznego oraz ślad zbiegu, który w tym przypadku jest punktem niewłaściwym osi x^n lub y^n , czyli ich kierunkiem. Podstawowym podobieństwem aksonometrii jako perspektywy równoległej, do perspektywy jako rzutu środkowego, jest wskazanie możliwości świadomego doboru kierunku

oglądu. W perspektywie można „obejść” wokół modelu i wybrać dogodny rzut stanowiska oraz określić jego wysokość poprzez położenie horyzontu. Tak też w aksonometrii prostokątnej jako perspektywie równoległej można świadomie dobrać rzut kierunku względem modelu oraz jego pochylenie poprzez wskazanie położenia rzutu początku układu O^n . Ta metoda konstruowania aksonometrii prostokątnej została opracowana przez dr inż. arch. A. Zdziarskiego oraz spopularyzowana na wydziałach Politechniki Krakowskiej oraz w UKL (Technische Universität Kaiserslautern) przez współautorkę niniejszego referatu [4]. Opiera się ona, podobnie jak zasada konstruowania tzw. "perspektywy stosowanej", na bazie rzutów prostokątnych.

W kolejnych etapach pracy autorzy przedstawiają następujące zagadnienia:

- Analiza doboru parametrów aksonometrii tj.: dobór rzutni, przyjęcie układu współrzędnych kartezjańskich $Oxyz$ w zależności od przyjętego kierunku obserwacji,
- Wariantowa analiza doboru kierunku obserwacji obiektu 3-wymiarowego za pomocą doboru wektora k' oraz punktu O^n ,
- Opis innowacyjnej konstrukcji aksonometrii prostokątnej,
- Analiza porównawcza rozważanej metody konstruowania aksonometrii prostokątnej (perspektywy równoległej) i perspektywy jako rzutu środkowego.

Metoda opisana przez autorów znajduje zastosowanie w praktycznym, konstruowaniu wizualizacji obiektów 3-wymiarowych. Jest na tyle przejrzysta, iż wspomaga kształtowanie wyobraźni przestrzennej. Poprzez analizę parametrów doboru kierunku obserwacji i sterowania jego pochyleniem otrzymujemy przystępną metodę na zrozumiałe i przewidywalne kształtowanie obrazu aksonometrycznego.