

NITROGEN OXIDES EMISSION ESTIMATOR FOR A DIESEL ENGINE USE TO REDUCE THE EMISSION OF HARMFUL SUBSTANCES IN EXHAUST GAS TO ENVIRONMENT

Mariusz Graba, Jarosław Mamala, Andrzej Bieniek, Krystian Hennek

Opole University of Technology
Faculty of Mechanical Engineering
Mikołajczyka Street 5, 45-271 Opole, Poland
tel.: +48 77 449 8439, +48 77 449 8437
+48 77 449 8447, +48 77 449 8449, fax: +48 77 449 8446
e-mail: m.graba@po.opole.pl, j.mamala@po.opole.pl
a.bieniek@po.opole.pl, k.hennek@po.opole.pl

Abstract

This article reports the results of experimental and numerical analysis of emissions of nitrogen oxides in exhaust gas to the environment from a turbocharged diesel engine of a tractor. The problem of identifying nitrogen oxides emissions from the exhaust gases was formulated and subsequently solved, based on data gained from measurements. The results of estimation of nitrogen oxides emissions were verified on the basis of research on a test object. The object of the study and a non-linear static model of nitrogen oxides emission were also described for two systems – with and without exhaust gas recirculation. The article demonstrates that the use of an adequately selected mathematical model can lead to the estimation of emissions of nitrogen oxides contained in the exhaust gas of diesel engines in an off-road vehicle. The created model can be used to control the valve of the exhaust gas of recirculation system and so reduce the emission of harmful substances to the environment. The presented research results show the comparison of estimated and measured nitrogen oxides concentration. The estimated value from the mathematical model concentration is about from 0.7 s to 1 s earlier than the value measured by the sensor, therefore the exhaust gas recirculation system could be controlled accordingly before nitrogen oxides are formed.

Keywords: *nitrogen oxides emission, diesel engine, estimation, combustion engines, air pollution, environmental protection*

1. Introduction

The development of society, economic growth and improved standard of living are closely attributable to the expansion of a wide range of means of transport such as road and off-road vehicles, vessels and aircraft. Adequate power units powered by various sources are applied in all of these means of transport. In addition, the energy conversion process in an internal combustion engine involving is the combustion process of fuel in the cylinder, accompanied by the emission of harmful compounds of the exhaust gases to the environment.

These are some of the most significant problems associated with the operation of internal combustion engines and identification of a suitable solution to this problem has been sought for a long time. The main reason for difficulties in finding simple solutions is associated with the cyclic energy conversion processes occurring in a combustion engine, linked to the periodicity, lack of stationarity, considerable degree of non-linearity.

However, during the normal operation, the internal combustion engine changes its characteristics, such as the emission of harmful substances in exhaust gases which depends on the technical condition of the engine. This problem has not been dealt with in the case of off-road vehicles. Therefore, it is reasonable to conduct research related to the development of emission models based on the basic engine operating parameters, with a potential for application to determine emissions of harmful compounds to the environment.

For these reasons, many research centres are looking for different design solutions including exhaust gas after-treatment systems. Nevertheless, considerable potential is seen in the adequate control of the engine, as it can be followed by the reduction of primary emissions. Among other things, it is recognized that a significant reduction of nitrogen oxide emissions to the environment can be achieved through an adequate control of exhaust gas recirculation valve – EGR, not always following conventional standards [7, 10]. Thus, in order to be able to control the exhaust gas recirculation valve the development of a mathematical model to be applied for evaluation of NO_x concentration is necessary [1]. The model developed in such a manner can lead to appropriate decisions regarding the recirculation level.

A model for estimating the amount of emissions of nitrogen oxides emitted into atmosphere is reported in works by Arregle [3] and Marchewko [12]. However, a significant impact on accuracy of models proposed by mentioned authors is the measurement of error of used sensors. Even minor inaccuracies of the sensor signals (by as little as $\pm 5\%$) can lead to distortions in the estimation of NO_x concentration by as much as $\pm 60\%$ [3]. A similar approach to the problem of estimating the concentration of nitrogen oxides is described in [2].

The amount of exhaust gas being recirculated is controlled by the use of a control valve (commonly referred as the EGR valve). The increase of the opening degree of the valve causes larger volume of exhaust gas to be recirculated and results in the reduction of NO_x emission into the atmosphere. However, this process leads to an increase in the particulate matter PM emission into the environment [4, 6].

The emission of particulate matter can be reduced by increasing the ratio of air-fuel mixture, using an adequate control of angle of the flow entering the turbine vanes as well as changing air feed ratio [9].

Due to the fact that the internal combustion engine is a non-linear object and the composition of fuel-air mixture in the combustion chamber of diesel engine can't be measured by traditional and commonly accessible sensors, it is suggest to the development of a static mathematical model of compound emissions of the exhaust system of a tractor engine, equipped with a primary exhaust gas purification system: an external exhaust gas recirculation system. A model developed in this way can be applied for the control of the exhaust gas recirculation system with the purpose of reducing emissions of nitrogen oxides, without interfering in the normal engine operation. This task requires identification research of test object, the development of static model and then on this basis development of a dynamic model.

2. Experimental research

The design of the original exhaust gas recirculation system was greatly advanced and it was coupled with an internal combustion compression ignition engine. This system was integrated with the engine and it form the object of the research reported here. The test object was installed on an engine dynamometer, which is located at the Department of Road and Agricultural Vehicles, University of Opole. The engine has an output power of up to 92 kW at 2200 rpm · min⁻¹ and includes a prototype mechatronic valve injection pump [5], turbocharger and pressure bypass valve and intake air cooler assembly, exhaust gas recirculation system with a fully programmable recirculation valve and an exhaust gas cooler (Fig. 2).

Furthermore, an advanced integrated sensor of oxygen, nitrogen oxide NO_x/O₂ was used in the exhaust system with many additional sensors, including fuel pressure sensors and in cylinder pressure.

The identification of dynamic properties of the control objects is a complex task that schematically can be defined as the development of an optimal mathematical model of an object on the basis of the experimental data gained from this object. Optimal in this context means that the target is most suitable from the point of a given criterion (that is usually mathematical). In fact, such identification is a complex multi-stage task [11].

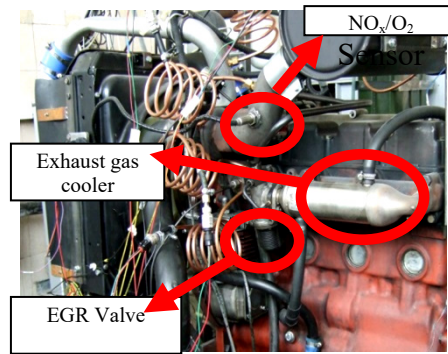

Fig. 2. EGR system equipped with proportional solenoid, exhaust gas cooler and the NO_x/O₂ sensor

The selection of the model class for control purposes forms an important step of the identification. In this case, a non-linear static model of the combustion process was first proposed, which was developed on the basis of engineering intuition, expertise, and established by trial and error technique on the basis of a large number of experiments. This is a simplified model, whose output takes the form of an estimate regarding the concentration of NO_x, which is a process variable associated with the control task.

Output values from the sensors offer a wide range of variations. It was assumed that each measured value is the ratio of the measured value and the value of standardization (equation 1). The standardization values are based on preliminary studies, presuming a principle that standardization value X_n of the signal X is calculated using the formula:

$$X_n = 0.75 \cdot X_{max}, \quad (1)$$

$$x = \frac{X}{X_n}. \quad (2)$$

X_{max} is the maximum value of the signal recorded during the test or a value that was found to be physically limited. The coefficient value was taken to be equal to 0.75 on the basis of a large number of experiments aimed at identification.

Figures show the data recorded by measuring system (Fig. 3a) and the same data after standardization process (Fig. 3b).

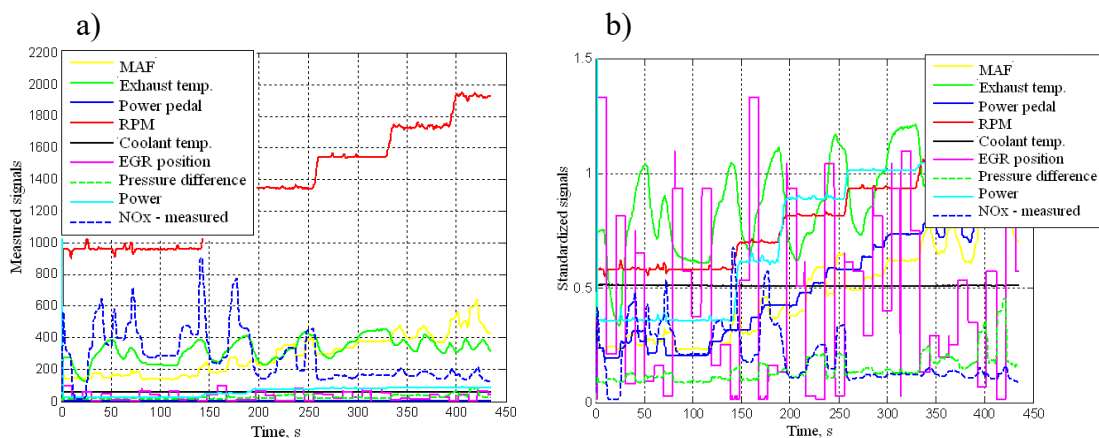

Fig. 3. Measurement data: a) registered during the test, b) standardized

Additional sensors are installed on the test stand with the purpose measuring various values, which were limited to include only input data needed to estimate the concentration of nitrogen oxides at any given point in the engine operation. On the basis of selected measurement signals of process variables, Fig. 3b contains a model of nitrogen oxide emissions from a combustion

ignition engine together with the results registered during one of the tests (in the conditions of variable engine operation). The signal representing the concentration of nitrogen oxides has been registered by a monolithic nitrogen oxide and oxygen sensor. The signal was additionally used to verify the developed model.

The SISO model “single input, single output” with multiple measurable interference and unmeasurable noise affecting the object was adopted for the analysis of the internal combustion engine, more specifically the NO_x emissions. Examples of unmeasurable interference affecting in terms of NO_x emissions include engine load, humidity of intake air, pressure of the ambient air and the quality and composition of the fuel. Therefore, the process of modelling was initially divided into two models: first one without exhaust recirculation and the second one with the exhaust gas recirculation system. The input for the static model without exhaust gas recirculation, was adopted to assume that $U = U_{std}$ for the position of accelerator pedal, $\beta = \beta_{std}$ in the steady state, since the operator gives an input only through this actuator to the internal combustion engine. This model is called the “initial” (Fig. 4a) as it does not account for the target control responsible for the opening of the regulation valve α . The methodology of developing the “initial” model is simpler than the “target” model (i.e. the one including the exhaust gas recirculation system), as the latter takes into account the α control.

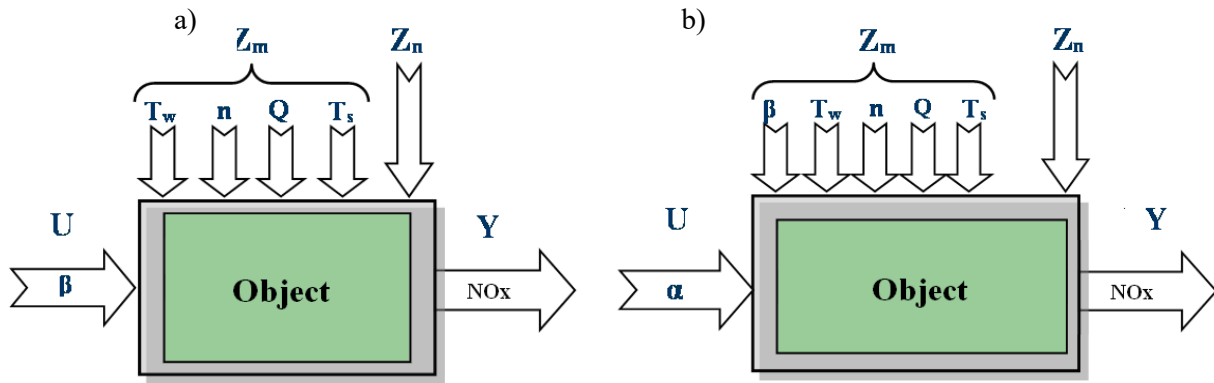

Fig. 4. General scheme of nitrogen oxide emissions: a) without exhaust gas recirculation, b) with exhaust gas recirculation, were: β – position of accelerator pedal, α – degree of EGR valve opening, NO_x – model output, concentration of nitrogen oxides, measurable disturbances Z_m : T_w – coolant temperature, n – speed Q – flow rate of intake air, T_s – temperature of exhaust gas, unmeasurable disturbances Z_n (for example – humidity, air pressure, load, fuel quality, etc.)

The level of NO_x in the steady state was taken as the output of the static model, both the “initial” and the “target” one. Other available measurement signals were assumed to be measurable disturbances, because directly or indirectly they result from the interaction between the operator acting on the pedal force and the effect of environmental interaction on the object. The measurable interferences include: coolant temperature, engine speed, mass flow rate of the air and exhaust gas temperature.

The static properties in the considered “initial” NO_x emission process can be represented as:

$$Y_i = f(U, Z_m) + Z_n. \quad (3)$$

For the model with exhaust gas recirculation, the input changes. During the development of a mathematical model for control purposes, we have to pay attention to the way in which the control system is able to interact with the test object. With regard to the exhaust gas, recirculation system described here, α signal representing the degree of recirculation valve opening forming the only input through which the controller affects this system (Fig. 4b).

Hence, the description of static properties considered in “target” NO_x emission takes the form:

$$Y_t = f(U, Z_m) + Z_n. \quad (4)$$

In equations (3) and (4) there are U as input signals: α – degree of EGR valve opening, β – position of accelerator pedal, NO_x – model output, concentration of nitrogen oxides, measurable disturbances Z_m : T_w – coolant temperature, n – speed Q – flow rate of intake air, T_s – temperature of exhaust gas, unmeasurable disturbances Z_n (humidity, air pressure, load, etc.).

3. Results and discussion

The estimation of NO_x concentration for both models was implemented using an original script developed in MATLAB/ Simulink, as shown in Fig. 5.

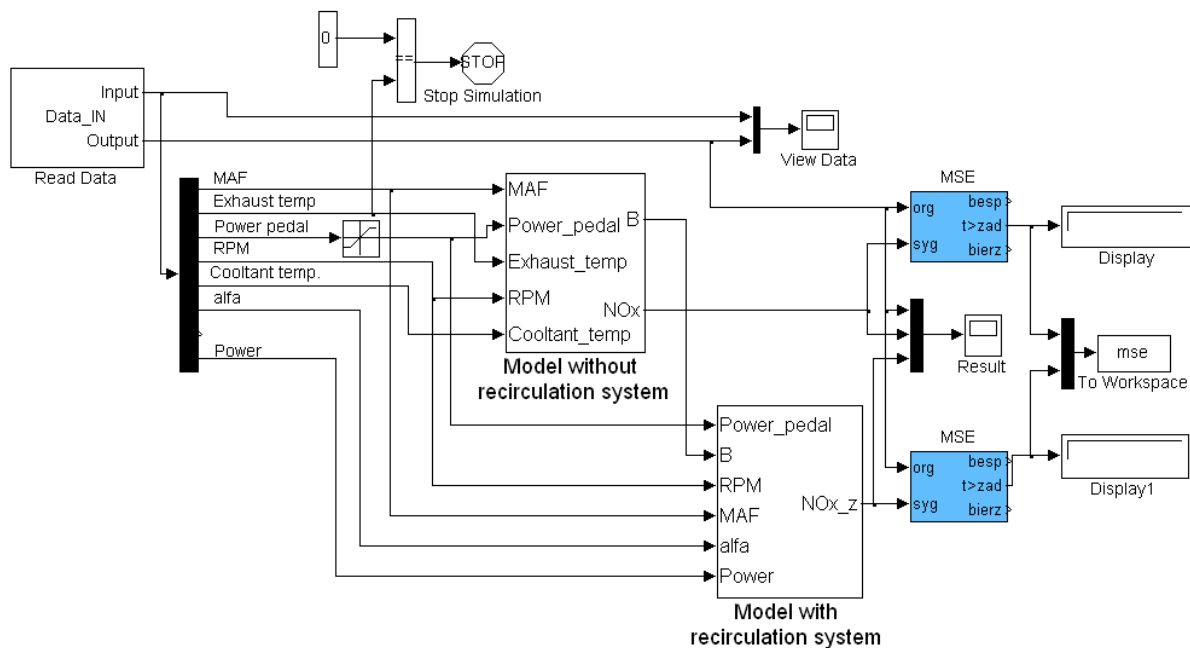

Fig. 5. NO_x Estimator simulation model in MATLAB/Simulink program

The recorded data is stored in the computer memory. Firstly, it is converted into an adequate format. This involves signal selection, filtration, standardization and setting the sampling frequency to the model, as visible in the block on the left side of the script. Blocks (mathematical models) found in the middle of the scheme are used to estimate the concentration of NO_x engine emission without and with recirculation system. The "MSE" block was implemented to the program, which determines the accuracy of calculations using the mean square error (MSE), which is calculated at each stage from the formula:

$$MSE = \sum_{k=1}^N (\text{measured_signal}(k) - \text{estimated_signal}(k))^2. \quad (5)$$

The combination of both models, i.e. the model with and without recirculation in a simulation program offers deeper insight in the operation of the recirculation system, in particular, the EGR valve. The special case considered for the closed EGR valve ($\alpha = 0$) is that both models calculate the same value of NO_x concentration.

Engine operation without exhaust gas recirculation involves a lack of gas flow back into the combustion chamber omitting the internal exhaust gas recirculation. The EGR valve is in the closed position ($\alpha = 0$), so only fresh air and fuel are supplied to the combustion chamber. Only selected data carrying information about the operating point of engine was selected among the signals registered by various sensors in the engine. Three primary signals were selected, which

form input data for the calculations regarding the concentration of NO_x along with two additional signals, which served to adjust the estimated value of NO_x. The basic signals include the position of accelerator pedal, engine speed and mass rate of intake air. Exhaust gas temperature measured in exhaust manifold and the coolant temperature measured at engine block are selected as additional correction signals. As a result, the following static model of system without NO_x recirculation, which is a concentration estimator of NO_x, is suggested:

$$NO_x = \frac{\beta - n + B}{Q}, \quad (6)$$

where:

- B – correction factor,
- β – position of accelerator pedal,
- n – engine speed,
- Q – mass flow of the intake air.

Below is an example of test verifying the model which involved a simulation of a drive at a constant engine speed (at certain intervals), with the engine load as a random variable presented. Such a test simulates e.g. uphill and downhill drive, where to maintain a constant speed (blue line); the opening degree of the accelerator pedal (black line) needs to be adequately increased or decreased. The measurement data gained from test is found in Fig. 6a.

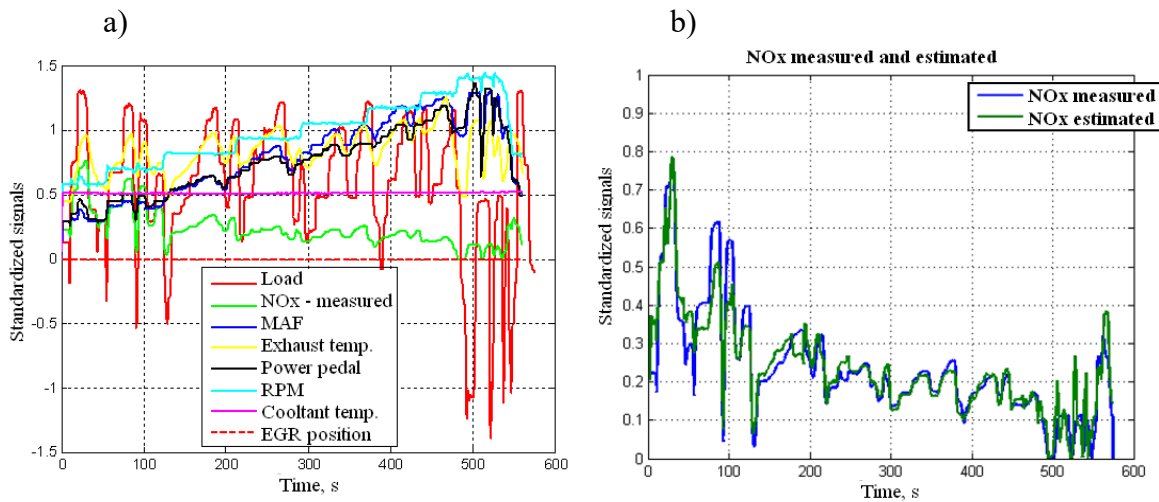

Fig. 6. An example of test procedure: a) measurement data for variable load and constant speed, b) comparison of model response with engines measured NO_x concentration with impact of unmeasurable interference

A constant speed is maintained for some time; it is then changed and remained constant for some time. The red colour represents load variation during the simulation. It could be noted along with an increase in the load for a constant rotational speed, the air flow rate (marked with yellow line) changes significantly.

The simulation result (NO_x estimation) is shown in Fig. 6b, and the mean square error was found to be 1.43. The change of engine's temperature needs to be taken into account in the calculation with the variation in NO_x concentration. This phenomenon has been accounted for in the mathematical model of engine's NO_x emissions (in B correction factor). Therefore, the selection of a factor plays an important role in the implementation of high-accuracy model (formula 6), which takes the form of the function $B = B(t)$ which is calculated using a special algorithm designed for this purpose.

Similar to the case of the system without exhaust gas recirculation, the estimation of the NO_x concentration in the engine with exhaust gas recirculation (α – var.), adopted the same set of measurement signals. Another signal available from measurement is the degree of the EGR valve

opening (α), expressed in percent [%]. Both the impact of the installation of the EGR valve and the entire exhaust gas recirculation system are accounted for in the C parameter in the static model. It can be seen that equation (7) of the model with recirculation slightly differs from the model without recirculation (6) – the parameter C forms the additional term in the latter model. In addition, for $\alpha = 0$ and the parameter $C = 0$, those two models give equivalent results. The static model of NO_x emission with exhaust gas recirculation system is described in the following form:

$$N\hat{O}_x = \frac{\beta - n + B}{Q + C}, \quad (7)$$

$$C = Q_\alpha \cdot P, \quad (8)$$

where:

C – exhaust gas recirculation system parameter,

Q_α – flow rate of exhaust gas through the valve depending on its opening degree (position), depended also on differential pressure in/out EGR valve,

P – power calculated from the engine characteristics.

The results of model verification with the exhaust gas recirculation system are found below. In this test, the engine was set at random operating points (at certain intervals), following varying positions of the accelerator pedal. In this test, the position of EGR valve was adjusted to vary randomly every 10 s. The conditions of the test are shown in Fig. 7a, and result of model implementation is shown in Fig. 7b.

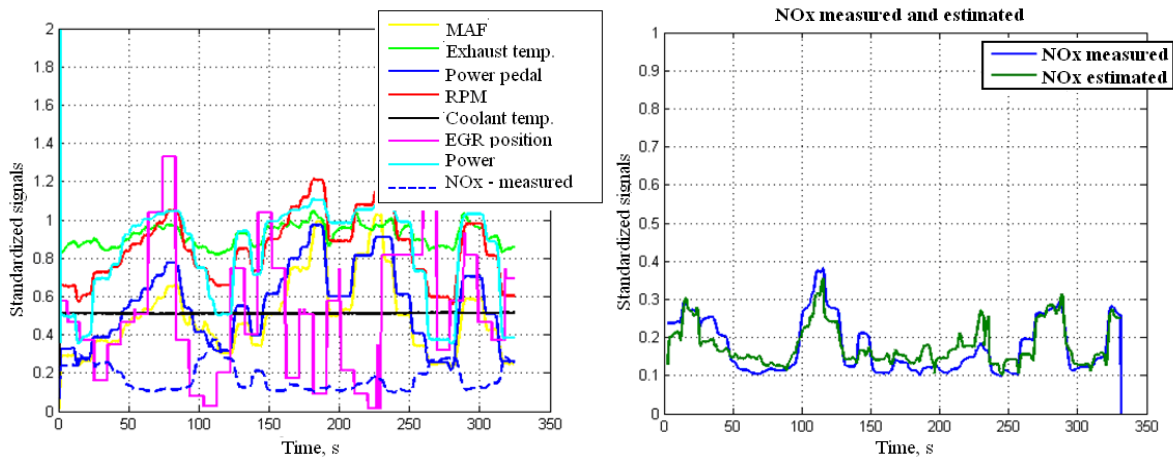

Fig. 7. Example of test results: a) measurement data for variable load and constant speed, b) comparison of model response with measured NO_x concentration including the impact of immeasurable and measurable interference

The mean square error for the test reported here was 0.40 for the system with exhaust gas recirculation, whereas during the same test, the error in model without recirculation was 101.94.

4. Conclusions

As a result of a study with regard to the mechanism of NO_x compounds formation during the combustion process and various experiments, three basic signals (measurable) and two auxiliary/correction (immeasurable) signals were identified with the purpose of adequate description of the level of NO_x formation in a combustion engine. As a result of experiments, it was found that the selection of an appropriate signal sampling frequency and the choice of an appropriate algorithm used for filtering measurement signals plays a significant role on the estimation of NO_x concentration and thereby on the calculated mean square error during the test. Furthermore, standardization of the measurement signals was found to have an effect on the model

accuracy, in such a way that the variability of the signals needs to remain in the same range.

During the tests of the static model, it was found to be able adequately to estimate the content of NO_x in the exhaust gas. On the basis of this model, a static model was subsequently developed, taking into account exhaust gas recirculation with an exhaust gas flow control valve. It was also able to estimate the content of NO_x in the exhaust gas in the conditions of random changes of the operating points of the engine.

The use of the proposed model can lead to reduce of the emission of harmful substances to the environment. The control system of the exhaust gas recirculation system works with an estimated by the model level of the NO_x before the rise in the combustion process. As a result of this estimation, the recirculation control system decides about exhaust gas flow before, and not after, the formation of nitrogen oxides, as is the case in a standard system, which reacts to the already produced substances. Such control can contribute significantly to the reduction of emissions of toxic substances into the environment.

References

- [1] Aithal, S. M., *Modeling of NO_x formation in diesel engines using finite-rate chemical kinetics*, Elsevier Applied Energy, 87, pp. 2256-2265, 2010.
- [2] Andersson, M., Nöhre, C., Johansson, B., Hultqvist, A., *A Real Time NO_x Model for Conventional and Partially Premixed Diesel Combustion*, SAE Technical papers, 2006.
- [3] Arregle, J., Lopez, J., Guardiola, C., Monin, C., *Automotive Model Predictive Control, On Board NO_x Prediction in Diesel Engines: A Physical Approach.*, Springer, Berlin 2010.
- [4] Bieniek, A., Mamala, J., Graba, M., *Analysis of combustion process at multiphase injection at nonroad diesel engine*, Combustion Engines, No. 3/2011 (146), 2011.
- [5] Bieniek, A., Mamala, J., Graba, M., Brol S., Augustynowicz, A., Lechowicz, A., *Zasilanie silników wysokoprężnych pojazdów pozadrogowych*, Studia i monografie, Wydawnictwo Politechniki Opolskiej, Z. 312, 2012.
- [6] Bieniek, A., Mamala, J., Graba, M., Lenc-Brol, A., *Adaptive control of exhaust gas recirculation at nonroad vehicle diesel engine*, Combustion Engines, Nr 3/2011 (146), 2011.
- [7] Ferreau, H. J., Ortner, P., Langthaler, P., del Re, L., Diehl, M., *Predictive control of a real-world Diesel engine using an extended online active set strategy*, Elsevier Annual Reviews in Control, 31, 293-301, 2007.
- [8] Graba, M., Bieniek, A., Mamala, J., Lechowicz, A., *Sterowanie adaptacyjne systemem recyrkulacji spalin w aspekcie obniżenia emisji substancji szkodliwych dla klasycznego silnika ZS*, Inżynieria Rolnicza 5(130)/2011, ISSN 1429-7264, 73-80, 2011.
- [9] Heywood, J. B., *Internal Combustion Engine Fundamentals*. McGraw-Hill Book Co, 1988.
- [10] Jantos, J., Mamala, J., Bieniek, A., Kowalski, D., Graba, M., *Pojazdy typu „Off Road” w aspekcie przyszłościowych norm emisji spalin*, Journal of KONES, Vol. 16, No 4, pp. 201-206, 2009.
- [11] Latawiec, K. J., *The power of inverse systems in linear and nonlinear modelling and control*, Studia i Monografie Politechniki Opolskiej, Opole 2004.
- [12] Marchewko, A., Prokhorenko, A., Ambroziak, A., *Metodyka obliczeń emisji tlenków azotu NO_x ze spalinami silników ZS i jej zastosowanie*, Journal of KONES, Vol. 7, No. 1-2, 2000.