

Long range measurements using a contactless low cost optical sensor

PAULO C.L. KRELLING¹, HIGINIO GONZÁLEZ-JORGE^{2*}, JULIA ARMESTO², PEDRO ARIAS²

¹Univesidade Federal do Paraná, Sector de Ciencias da Terra, Departamento de Geociencias, CEP 800000-000 – Curitiba, Paraná, Brazil

²Universidad de Vigo, Area de Ingeniería Cartográfica, Geodesia y Fotogrametría, 36310 – Vigo, Spain

*Corresponding author: higiniog@uvigo.es

Length measurement is very common in many industrial applications and there is a number of instrumentation involved, mainly dependent on the range and accuracy requirements. In this work, a contactless optical measurement unit is developed. It is based on a mouse sensor and an external laser source. The system is calibrated using an optical board and an electronic distance measuring system. Accuracy and precision of the system is evaluated using the reference data from a total station. Values of 1 mm and 0.3 mm are respectively obtained. Length range during the experiment is 8.5 m. The data of the optical measurement unit are compared with those obtained from a commonly used wheel encoder. Results from the optical sensor of the mouse improve the encoder data.

Keywords: laser scanning, accuracy, optical sensor.

1. Introduction

A number of metrological applications need to obtain position or length in moving objects. One example of instrumentation used in mid-range length measurements are the optical linear encoders included in coordinate measurement machines (CMM) and in the computer numerical control (CNC) machines that can provide micrometric accuracies [1]. Other examples in long-range measurements are the total stations, electronic distance meters (EDM), wheel encoders, inertial measurement units (IMU), used in indoor navigation, or global positioning systems (GPS) for millimeter or centimeter accuracies [2 –6].

Nowadays there are on the market mass produced and contactless motion measuring systems normally used as human interface devices (HID) for computers. These devices are the optical sensors integrated in a computer mouse. The measuring system has no moving parts, does not make contact with the surface and needs no maintenance.

The mouse systems consist mainly of three parts: lens, light source and mouse sensor. They are all typically assembled in a custom printed circuit board. The mouse sensor takes grey scale images of the underlying surface. These images typically vary from 16×16 pixels to 30×30 pixels, depending on the image sensor used. Image quality not only depends on the image/sensor size. It also depends on lens quality and the wavelength and corresponding color of the light surface. The light color can affect the contrast of the surface image. The signal can contain from 256 bytes for a 16×16 pixel image to 900 bytes for a 30×30 pixel image, depending on the size of the image acquisition system. The electrical signals of the images are processed in the digital signal processor (DSP). The DSP measures changes in position by comparing the images sequentially taken of the surface and gives the relative displacement values of X and Y . The program to compare and calculate the relative displacement is provided by the mouse sensor manufacturer. The microcontroller reads the X and Y information and sends it to the computer by the serial port (RS232, USB) [7–9].

Although the optical mouse sensors appear as very promising devices for length measurements in low cost applications, more research about calibration, precision and accuracy must be done to use these systems, especially in long range length measurements. This work shows an experimental arrangement to perform length measurements using the optical sensor included in a computer mouse. In addition, the system metrology is compared with the data obtained from a total station and a wheel encoder to evaluate accuracy and precision.

2. Materials and methods

Optical sensor is integrated in a generic M5033 notebook mouse. Tracking resolution is 800 dpi. The system can work on most of surfaces without a mouse pad. PS2 and USB ports are available. Dimensions are $100 \times 60 \times 36$ mm ($L \times W \times H$). It supports Windows 7, Vista, XP, 98 and 95.

All the optical mouse sensors have declared nominal resolutions in dpi. Usually, the real resolution differs from the nominal one and calibration is needed. There are different ways it can be made, although one of the simplest is comparing known distances with the number of pulses emitted by the mouse.

The optical mouse calibration was performed placing the system at approximately 150 mm from the surface (contactless use). Contactless measurements are important to integrate these optical sensors in moving vehicles or platforms. Figure 1 presents the calibration using a contactless process. The optical mouse uses a CMOS array sensor to take the images. The mouse has a small red LED diode that emits light to the surface which is reflected to the sensor. If the distance between the sensor and the surface is large and the light that reaches the CMOS sensor is not enough for activation, it appears that there is not movement. The solution proposed is to amplify the reflected light amount coming from the lighted surface. In this case, a green laser pointer with a pattern filter is used. The device is arranged in such way that makes approximately 100 mm of illuminated area. Software is developed to read the sensor

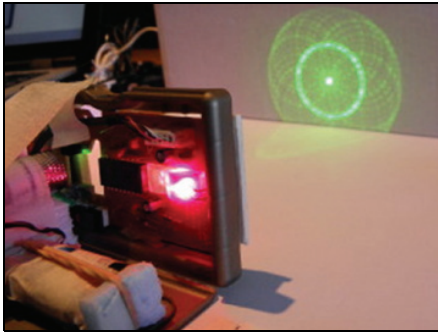

Fig. 1. Experimental arrangement for the calibration process using an external laser light source.

data. Calibration results differ slightly from the nominal values of the mouse (804 dpi – calibration vs. 800 dpi – nominal value). It reveals that the calibration process is very important to obtain accurate measurements. After calibration a resolution of 0.0311 mm/pulse is obtained with a standard deviation of 7 dpi.

The accuracy of a measurement system is the degree of closeness of measurements of a quantity to the quantity true value. The precision of measurement systems, also called repeatability, is the degree to which repeated measurements under unchanged conditions show the same results [10, 11]. To evaluate the accuracy and precision of the optical sensor, the system was assembled to a mobile system developed at the University of Vigo (Figs. 2 and 3). The test is performed in one of the corridors at the School of Mining Engineering. A tape was put on the floor to act only as a reference for the measurements and maintain a straight line during the displacement of the vehicle. The maximum range of the measurements was around 8.5 m. The set of the measurements is obtained at a step of approximately 50 cm. The measurements obtained through the calibrated optical sensor of the mouse were compared with those obtained from a total station and those obtained from the encoder system assembled to one of the wheels of the vehicle. The total station data were assumed as the reference value. The wheel encoder is a displacement sensor typically used in current applications of

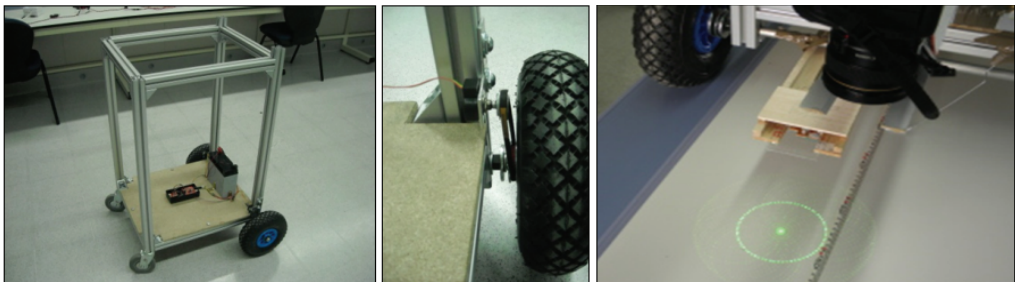

Fig. 2. Experimental arrangement for the accuracy and precision test. The first photograph shows the mobile system, the second one the encoder at one of the wheels and the third one the optical sensor at the rear part of the vehicle.

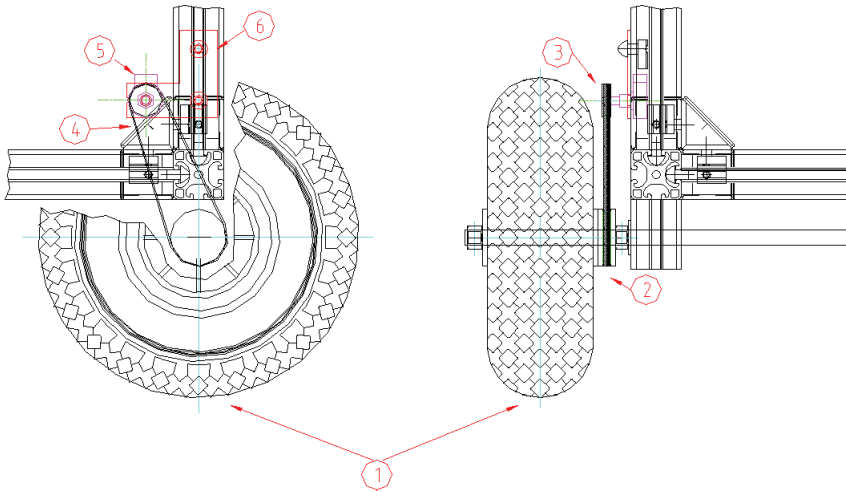

Fig. 3. Technical draw to show the assembly between the wheel and the encoder. 1 – wheel, 2 – gear wheel, 3 – gear encoder, 4 – pulley, 5 – encoder, 6 – encoder support.

motion monitoring in mobile systems. The comparison between the optical unit here developed and the wheel encoder is made because both would be oriented to a market segment with similar technical and price requirements.

The total station (Leica TCR 1102) shows an angular accuracy of 2" and a maximum length range between 3500 m and 80 m; the maximum range of measurement is determined using a prism. In this work, the total station was used in reflectorless mode targeting a mark specially draw on the vehicle structure. The accuracy of the distance measurement according to ISO 17123-4 is 2 mm + 2 ppm in standard measurement mode. In this work, the value for each position is averaged from 10 measurements to increase the precision of the system. The total station uses a red laser (633 nm wavelength) in phase measurement configuration. These instruments modulate the laser beam and measure the phase difference between the emitted and collected signals, which is proportional to the range measurements [12].

The wheel encoder (Honeywell 600-128-CBL) shows 128 pulses per revolution. The maximum operating speed is 300 RPM, operating torque 0.011 Nm, terminal strength 0.9 kg and 10 million shaft rotations are estimated for the maximum life of the system. The shaft axial force is 6.8 kg and the radial play 0.0254 mm. The shaft material is stainless steel. Operating temperature ranges between $-40\text{ }^{\circ}\text{C}$ to $65\text{ }^{\circ}\text{C}$.

The software used for the acquisition of the mouse data was the same that those previously used for the calibration.

3. Results

Figure 4 shows the results of the accuracy and precision tests. The accuracy is evaluated as the difference between the length measured by the total station (reference

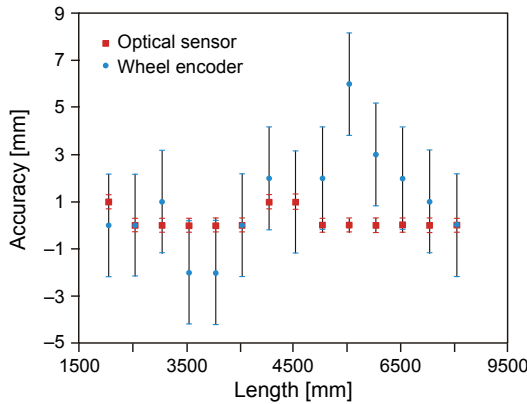

Fig. 4. Accuracy and precision (error bars) of the systems under study.

value) and the values obtained from the wheel encoder and the optical sensor. Precision is obtained from the standard deviation of the measurements and depicted through the error bars. The following equations exhibit the previous calculations:

$$A = L_{TS} - L_{WE/OS} \tag{1}$$

$$P = \sqrt{\frac{1}{N} \sum_{i=1}^N \left([L_{WE/OS}]_i - [L_{WE/OS}]_m \right)^2} \tag{2}$$

where A is the accuracy, L_{TS} – the length evaluated by the total station, $L_{WE/OS}$ – the length evaluated by the wheel encoder or the optical sensor, P – the precision and N – the number of repetitions.

Accuracy is obtained from the optical sensor and depicts values between 0 to 1 mm during all the measurement range, while in the case of the wheel encoder accuracy decreases to values between –2 mm to 6 mm. In both cases, there is not observed any trend between the accuracy and the increase of the distance. Precision obtained from the statistical analysis of the data also shows better behavior for the optical sensor. The precision value of the optical sensor depicts 0.3 mm, while the wheel encoder exhibits 2.18 mm.

4. Conclusions

A low cost contactless optical sensing device, based on the sensing unit of an optical mouse and a complementary external laser source, is developed to make length measurements in mobile systems. The system is calibrated using an optical table and an EDM. The metrological characteristics of the system in length measurements are tested using an indoor vehicle. The results are compared with a total station and with a commonly used wheel encoder. The optical sensing unit shows high accuracy and repeatability, improving the results of the encoder. The contactless distance measure-

ments appear very interesting in applications where the traditional encoder assembly became difficult. One example is the LiDAR mapping systems integrated in vehicles with non-accessible wheels (*i.e.*, trains or special machinery). In addition, the optical sensing unit depicts more rough and reliable calibration results than wheel encoders, especially in mobile systems with pneumatic tires. In this case, the encoder calibration is subjected to changes which come from the temperature or pressure of the tire.

Acknowledgements – This work was made with the financial support of the Spanish Ministry of Science and Innovation (Grant No. BIA2009-08012), the Spanish Centre for Technological and Industrial Development (Grant No. IDI-20101770), Xunta de Galicia (human resources grant IPP055-EXP44) and CNPQ (National Council for Scientific and Technological Development), Brazil human resources program – Post Doctorate.

References

- [1] ASTON R.A.E., DAVID E.J., DUFFILL A.W., *The calibration of co-ordinate measuring machines and touch triggerprobes*, [In] *Laser Metrology and Machine Performance V*, G. N. PEGGS, National Physical Laboratory, United Kingdom, 2001, pp. 127–136.
- [2] PETRIE G., *Mobile mapping systems: an introduction to the technology*, *Geoinformatics* **13**(1), 2010, pp. 32–43.
- [3] KAVANAGH R.M., *Gyroscopes for orientation and inertial navigation systems*, *Kartografija i Geoinformacije* **6**, 2007, pp. 254–271.
- [4] RIEGER P., STUDNICKA M., PFENNIGBAUER M., ULLRICH A., *Advances in mobile laser scanning data acquisition*, FIG Congress, 2010, Sydney, Australia.
- [5] FU G., MENCIASSI A., DARIO P., *Development of a low-cost active 3D triangulation laser scanner for indoor navigation of miniature mobile robots*, *Robotics and Autonomous Systems* **60**(10), 2012, pp. 1317–1326.
- [6] CHENG CHEN, WENNAN CHAI, NASIR, A.K., ROTH, H., *Low cost IMU base indoor mobile robot navigation with the assist of odometry and Wi-Fi using dynamic constraints*, *IEEE/ION Position Location and Navigation Symposium (PLANS)*, 2012, pp. 1274–1279.
- [7] OWENS R.L., *Optical mouse technology*, 2006; <http://home.comcast.net/~richardlowens/Optical-Mouse/>
- [8] KAMPHUIS W.P.H., *Using Optical Mouse Sensors for Sheet Position Measurement*, Ph.D. Thesis, Eindhoven University of Technology (TU/e), Netherlands, 2007; <http://www.mate.tue.nl/mate/pdfs/7846.pdf>
- [9] ZABAleta H., VALENCIA D., PERRY J., VENEMAN J., KELLER T., *Absolute position calculation for a desktop mobile rehabilitation robot based on three optical mouse sensors*, 2011 Annual International Conference of the IEEE Engineering in Medicine and Biology Society, EMBC, 2011, pp. 2069–2072.
- [10] GONZÁLEZ-JORGE H., RODRÍGUEZ-GONZÁLEZ P., GONZÁLEZ-AGUILERA D., VARELA-GONZÁLEZ M., *Metrological comparison of terrestrial laser scanning systems Riegl LMS Z390i and Trimble GX*, *Optical Engineering* **50**(11), 2011, article 116201.
- [11] GONZÁLEZ-JORGE H., RIVEIRO B., ARMESTO J., ARIAS P., *Standard artifact for the goemetric verification of terrestrial laser scanning systems*, *Optics and Laser Technology* **43**(7), 2011, pp. 1249–1256.
- [12] GONZÁLEZ-JORGE H., RIVEIRO B., ARMESTO J., ARIAS P., *Procedure to evaluate the accuracy of laser-scanning systems using a linear precision electro-mechanical actuator*, *IET Science, Measurement and Technology* **6**(1), 2012, pp. 6–12.

*Received July 11, 2012
in revised form October 5, 2012*