

Bogdan Pojawa*

OPERATIONAL DIAGNOSTICS SYNTHESIS OF THE NAVAL GAS TURBINES OPERATED BY THE POLISH NAVY

ABSTRACT

The article presents overall energy research conducted by the Polish Naval Academy for the purpose of operational diagnostics of the naval gas turbines operated by the Polish Navy. In this article are presented the purpose and methodology of research, identification of the object of research and test equipment used for research. The research results will be presented in another article *Analysis operational parameters of the naval gas turbines*. As far as the Polish Navy vessels are concerned, there were four types of the naval gas turbines operated in the years 1983–2003: DE 59, DR 76, DR 77 and LM 2500. Currently, since 2013, there are four LM 2500 engines in service, which drive ‘Oliver Hazard Perry’ type missile frigates. In the near term, another LM 2500 engine along with a 661M type patrol boat will become operational. Within the framework of energy research, the engine starting process, running on idle and in the whole range of variation of load as well as the process of stopping the engines will be placed under systematic operational surveillance.

Key words:

technical diagnostics, naval gas turbine, technical condition, LM 2500 engine.

INTRODUCTION

At the present time, the operation of engines and broad technical equipment is aimed at increasing their reliability, higher performance and energy efficiency as well as minimizing operating costs and risks to people and the environment. These requirements entail increasing complexity of the organization of the operation process and

* Polish Naval Academy, Faculty of Mechanical and Electrical Engineering, Śmidowicza 69 Str., 81-127 Gdynia, Poland; e-mail: b.pojawa@amw.gdynia.pl

the number of necessary technical measures used in this field. Taking into account the fact that modern engines and technical devices are highly complicated, expensive and they often must meet numerous requirements, standards and regulations, e.g. in terms of environmental protection, they must be operated according to an appropriate operational strategy. The theory of operation deals with developing appropriate operational strategies as well as synthesizing, analyzing and studying operational systems, in particular the issues relating to the processes of using and operating machines included in these systems. Operational strategy is to establish ways of using and operating machines as well as relations between them in the light of the adopted criteria. The most popular operational strategies included in the theory of operation are as follows: based on reliability, based on economic efficiency, based on the amount of work done, based on technical condition. Operational system of the objects being considered is most often based on one of the above-mentioned strategies, while the elements of the other strategies serve as its supplement. In operational practice, mixed operational strategies are most popular. They are adjusted to the requirements and operational conditions of both engines and technical equipment [4, 20, 30, 31, 37, 40, 41].

Currently existing operational systems are usually multi-criteria and mainly based on the technical condition strategy and overall operating costs. This strategy is based on operational decision-making on the basis of the current assessment of the technical condition of the object (system) being operated. Therefore, technical diagnostics is very important in such systems. There are three main types of them: receiving, operational and overhaul diagnostics [41].

Operational diagnostics is essential to the operation process, which uses the results of measurements carried out periodically or continuously. The state of the object and its defects are both determined on the basis thereof [4, 30, 40, 41]. The symptoms of the state relating to the process variables (such as pressure, temperature, power) as well as residual processes which inevitably accompany the operation of each machine: thermal, electrical and above all vibroacoustic processes, are used to diagnose the device state within the operational diagnostics. They allow carrying out the diagnostic process without switching off the device (non-invasive diagnostics). In terms of operational diagnostics, two ways of diagnostic deduction [40, 41]:

- based on diagnostic systems using the symptom – state relation;
- based on a model using the state – model parameters relation.

Finally, the results of the operational diagnostics allow [20, 30, 31, 40, 41]:

- determining whether an object is functioning (or may be functioning) properly — utility diagnoses obtained from the study of the functional properties of an object;

- determining a prognosis relating to the expected lifetime of an object — this is usually done by determining the probability of the correct operation in a given period of time;
- the possibility to locate each damage (obtaining sufficiently accurate operational diagnoses);
- determining the cause of a damage.

The beginnings of operational diagnostics of the naval gas turbines in the Polish Navy date back to 1985. At that time, as a result of putting into service of the four 1241 RE missile corvettes (fig. 1) (ORP 'Górnik', ORP 'Hutnik', ORP 'Metalowiec' and ORP 'Rolnik') equipped with modern — for those times — DR 76 and DR 77 naval gas turbines (eight DR 76 engines and eight DR 77 engines) and the 61MP missile destroyer ORP 'Warszawa' (fig. 2) with DE 59 engines (four engines), there was a need to organize a diagnostics system (20 engines in total). Since 1985, at the Institute of Shipbuilding and Marine Propulsion, there were many scientific research papers [5, 15, 28, 32] carried out and doctoral theses defended [19, 24, 29, 39] under the guidance of Professor A. Charchalis. They focused on diagnosing this type of engines. They dealt with developing effective diagnostic methods that could be used in operating conditions of marine engines [1–3, 6–10, 14, 21, 22, 25, 34]. In the 1990s, their results made it possible to develop and implement an underlying multi-symptom system for diagnosing naval gas turbines operated in the Polish Navy [5, 11, 12, 27]. This system enabled a transition from the operational strategy based on the amount of work done to the technical condition strategy. Experiences acquired in this field were used in the operation of LM 2500 naval gas turbines (4 engines) which were put into service in the Polish Navy in 2000 together with 'Oliver Hazard Perry' type missile frigates (fig. 3). (ORP 'Pułaski' and ORP 'Kościuszko') [33].



Fig. 1. 1241 RE missile corvette ($D = 490$ t, $v = 45$ w; D — displacement, v — speed of ship) [42]



Fig. 2. Missile destroyer ORP 'Warszawa' ($D = 4\,950\text{ t}$, $v = 32\text{ w}$; D — displacement, v — speed of ship) [42]



Fig. 3. 'Oliver Hazard Perry' type missile frigate ($D = 3\,600\text{ t}$, $v = 29\text{ w}$; D — displacement, v — speed of ship) [42]

In the subsequent years, since 2000 until the present time, the continuation of both scientific [18, 23, 33, 34] and service-scientific [36] research as well as doctoral dissertations [35] carried out in this field under the guidance of Professor Charchalis, Professor Korczewski and Professor Grzędziela has been retained. The underlying multi-symptom diagnostic system is still being developed and modernized. It consists of a number of diagnostic stations allowing for a comprehensive assessment of the technical condition of naval gas turbines (in any configuration) and developing a prognosis for their further use. In technical terms, the system is equipped with specialized control, measuring and analytical devices which makes it possible to conduct diagnostic tests at a standstill and in normal operation in the sea [33, 34, 36].

In this article, due to the wealth of material, the issues relating to the operational diagnostics of naval gas turbines are shown only in the field of energy research. Therefore, the article presents the identification of testing object, purpose, methodology and apparatus used for research. The results of ongoing research will be presented in the next article.

IDENTIFICATION OF TESTING OBJECT

Since 1983, equipment available to the Polish Navy included the following naval gas turbines covered by operational diagnostics with the use of a underlying multi-symptom diagnostic system [6, 7, 21, 27, 42]:

- eight DR 76 engines (in the years 1983–2013);
- eight DR 77 engines (in the years 1983–2013);
- two DE 59P engines (in the years 1988–2003);
- two DE 59L engines (in the years 1988–2003),
- four LM 2500 engines (since 2000 until present).

In the near term, another LM 2500 engine will come into operation together with a 661M patrol boat ORP ‘Ślązak’. This boat will be equipped with a combined propulsion system CODAG which includes two 12V 596TE90 marine combustion engines MTU (sustainer engines) and LM 2500 naval gas turbine GE/AVIO (peak output engine) [42].

Naval gas turbines DR 76 and DR 77 were used in a combined propulsion system COGAG installed in 1241 RE missile corvettes. It consisted of two identical propulsion units on the board- and portside, connected by a transverse shaft. The propulsion system consists of two DR 76 naval sustainer gas turbines and two DR 77 naval peak output gas turbines (fig. 4). The total power of this propulsion system amounted to 23.500 kW. The torque from the engines was transmitted onto two lines of shafts by a cruising gear (CG) and onto a three-blade solid propeller by a peak gear (PG). The gear units were equipped with disengaging couplings (DC) which allowed for the following operating modes [16, 27]:

- one sustainer engine (DR 76) and two propellers in operation, with the use of a transverse shaft;
- autonomous operation of sustainer engines (DR 76), each with its propeller;
- autonomous operation of peak output engines (DR 77), each with its propeller;
- operation of all drive engines (COGAG) with both sustainer and peak power engines on one side driving their propellers.

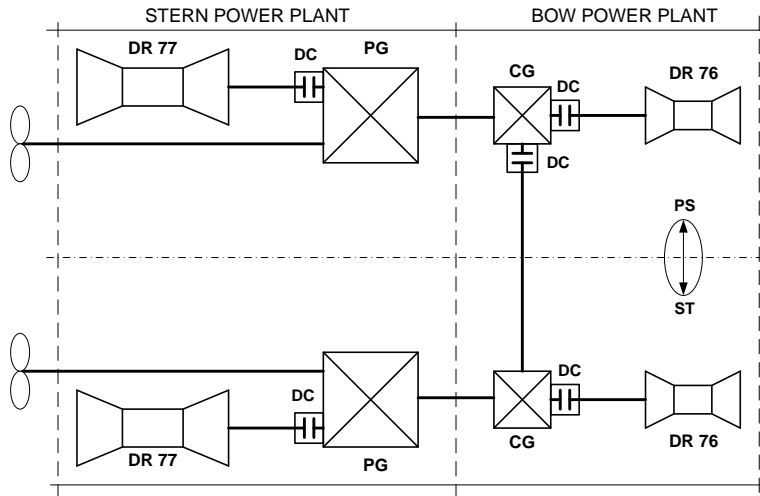

Fig. 4. Schematic diagram of a combined propulsion system (COGAG) of a 1241 RE missile corvette [16]

Both DR 76 and DR 77 included in the propulsion system of a ship had similar three-rotor design with a two-rotor gas generator, annular-tubular return combustion chamber and reversible power turbine [16]. Cross-section of an engine on the example of the DR 76 engine is shown in figure 5. Basic parameters of both DR 76 and DR 77 engines are presented in table 1. These engines consisted of the following main components [16]:

- eight-stage low-pressure compressor (LPC);
- nine-stage high-pressure compressor (HPC);
- annular-tubular combustion chamber (CC);
- one-stage high-pressure turbine (HPT);
- one-stage low-pressure turbine (LPT);
- three-stage reversible power turbine (PT).

Both low-pressure and high-pressure compressors along with their turbines formed two unconnected kinematic rotors (low-pressure and high-pressure respectively) rotating at different speeds in any range of engine operation. Both low-pressure and high-pressure rotors as well as the combustion chamber formed the gas generator. Reversible power turbine was a separate rotor, not connected kinetically with other rotors, located behind the low-pressure turbine. Power turbine rotor had three stages of 'forward' movement and one stage of 'back' movement. 'Back' blade ring was located above the blade ring of the 3rd stage of 'forward' movement and the direction of

exhaust flow was provided by adjustable blinds. The design of the engine's reversible mechanism included an indirect operational mode of the power turbine, so-called 'stop-propeller', in which gas-dynamic moments of both 'forward' and 'back' blade rings balanced against each other [16].

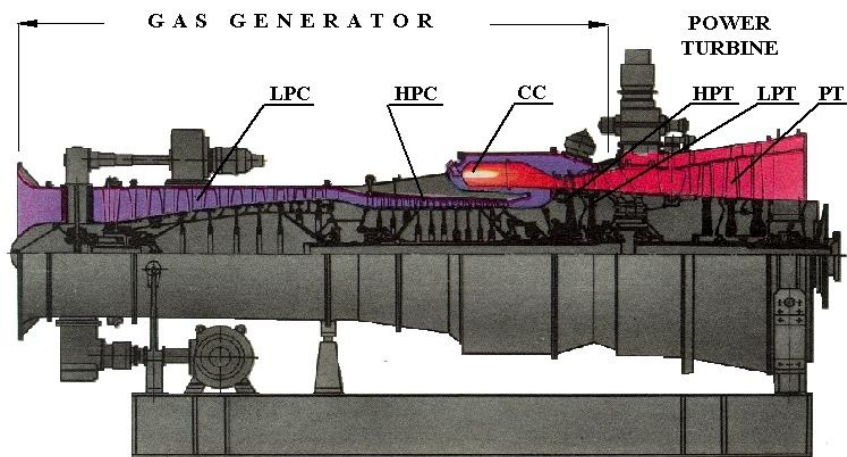

Fig. 5. Cross-section of the DR 76 and DR 77 naval gas turbines: LPC — low-pressure compressor, HPC — high-pressure compressor, CC — combustion chamber, LPT — low-pressure turbine, HPT — high-pressure turbine, PT — power turbine [16]

DE 59 naval gas turbines occurred in the combined propulsion system (COGAG) installed in the 61MP missile destroyer. It consisted of two identical propulsion units on the board- and portside. The propulsion system consisted of the four DE 59 naval gas turbines, including two DE 59P and two DE 59L engines, with the total power of 70.500 kW (fig. 6). The torque from the engines was transmitted onto two lines of shafts with the three-blade solid propellers. The gear units were equipped with disengaging couplings (DC) which allowed for the following operating modes [17]:

- one drive system's engine of the board- and portside in operation, each with its propeller;
- all drive engines in operation (COGAG), with drive systems of the board- and portside driving its propeller.

The DE 59 engines had also three-rotor design with a two-rotor gas generator, annular-tubular return combustion chamber and power turbine [17]. Cross-section of the DE 59 engine is shown in figure 7, while the basic operating parameters are presented in table 1.

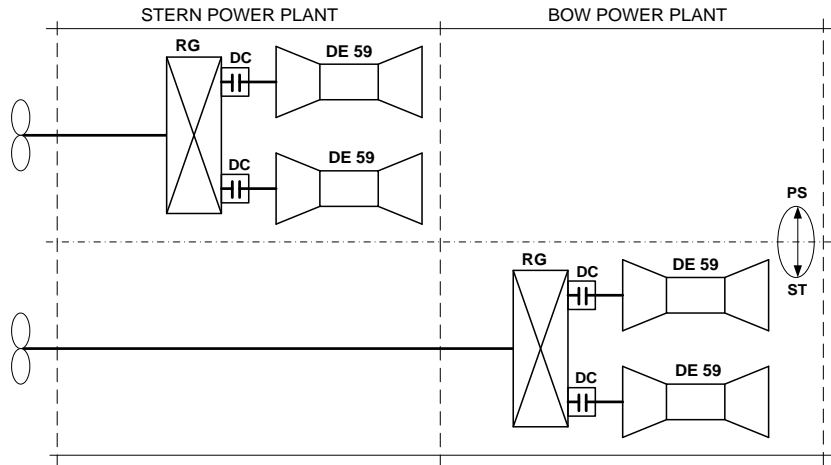

Fig. 6. Schematic diagram of a combined propulsion system (COGAG) of a 61MP missile destroyer [17]

The DE 59 engines consisted of the following main components [17]:

- eight-stage low-pressure compressor (LPC);
- nine-stage high-pressure compressor (HPC);
- annular-tubular combustion chamber (CC);
- two-stage high-pressure turbine (HPT);
- two-stage low-pressure turbine (LPT);
- two-stage non-reversing power turbine (PT).

'Back' movement was implemented in this propulsion system by a reduction-reversing gear.

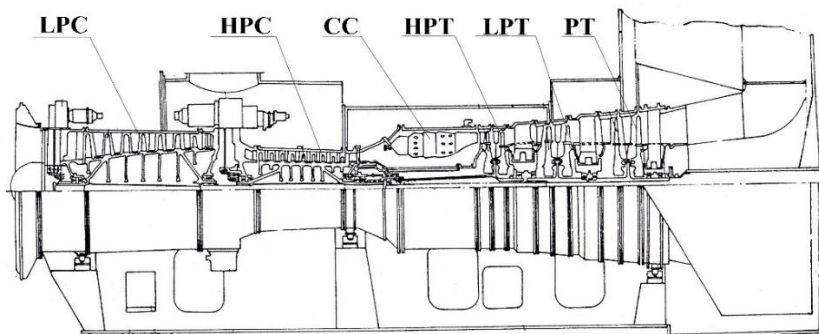

Fig. 7. Cross-section of the DE 59 naval gas turbine [17]

The LM 2500 naval gas turbines occur in a combined propulsion system (COGAG) installed in the 'Oliver Hazard Perry' missile frigates. The propulsion system

consists of two LM 2500 naval gas turbines, reduction gear and shaft line with five-blade adjustable propeller (fig. 8). The total power of this propulsion system amounts to 30.000 kW. The drive system allows for the following operating modes [38]:

- operation of one engine on the board- or portside;
- simultaneous operation of two engines on the board- and portside.

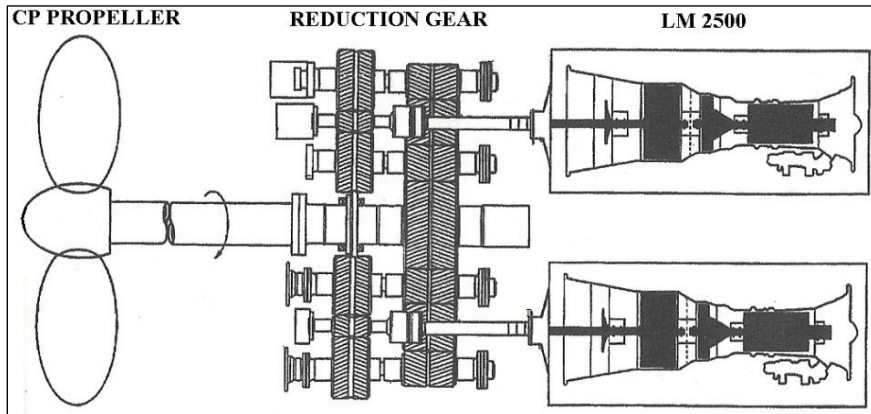

Fig. 8. Schematic diagram of a combined propulsion system (COGAG) of a 'Oliver Hazard Perry' missile frigate [38]

The LM 2500 engine is a two-rotor engine with a one-rotor gas generator. The gas generator consists of a sixteen-stage axial compressor, annular combustion chamber with 30 injectors and 2 starters as well as a two-stage axial gas generator turbine. The power turbine is a six-stage axial turbine [38]. The cross-section of the LM 2500 engine is presented in figure 9, while the basic operating parameters are presented in table 1.

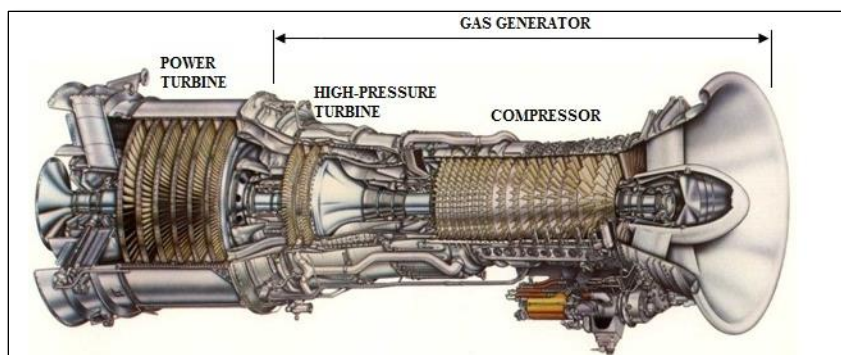

Fig. 9. Cross-section of the LM 2500 naval gas turbine [38]

The engines are installed in containers attached to the foundations by means of elastic dampers. Such a location allows for both noise and vibration absorption as well as protecting the marine power plant against the fire of the main engines. These containers provide a suitable temperature on the outside of the engine at a standstill and in normal operation. A container is also a base for automation devices (transmitters and sensors) as well as oil, fuel and (starting and control) air connections. In addition, inside the container, there are temperature and flame sensors that inform about the fire [38].

'Back' movement was implemented in this propulsion system by an adjustable propeller [38].

Tab. 1. Basic operating parameters for the rated working range of DR 76, DR 77, DE 59 and LM 2500 engines [16, 17, 38]

Parameter	Designation	Unit	DR 76	DR 77	DE 59	LM 2500
power output	P	kW	2940	8820	17 640	15 000
low pressure compressor speed	n_{LPC}	RPM	14 820	11 320	5800	–
high pressure compressor speed	n_{HPC}	RPM	20 700	14 400	7480	–
gas generator speed	n_{GG}	RPM	–	–	–	9500
power turbine speed	n_{PT}	RPM	8600	6400	5350	3600
specific fuel consumption	be	g/kWh	299	274	275	268
power turbine inlet exhaust gas temperature	T_{PT}	K	935	945	890	–
combustion chamber outlet exhaust gas temperature	T_{CC}	K	1285	1420	1090	1485
compressor pressure ratio	π	–	12.16	16.77	–	18.8
mass flow rate of air	\dot{m}_{air}	kg/s	14.36	32.28	–	70.1
effective efficiency	η_e	%	32	30	30	37

RESEARCH PURPOSE AND METHODOLOGY

The energy research for the purpose of operational diagnostic of naval gas turbines are conducted in order to [15, 26, 27, 33]:

- verify indications of marine control and measurement system;
- determine and assess changes concerning operating parameters of the engine during starting, idling, work with load and during stop (overrun);

- check the correct functioning of the automation system during start-up, while working with load and during stopping the engine;
- check the control parameters according to operational requirements, in particular during idling;
- analyse the operating characteristics of the engine;
- evaluate the fuel system in a steady state;
- assess the technical state of the flow part.

The energy research is carried out in accordance with the research methodology developed for the needs thereof [26, 27]. Energy research are always preceded by:

- calibration of sensors and measuring transducers;
- calibration of measuring lines, along with an indication of measurement uncertainties;
- checking the correct functioning of the systems used for measuring and recording systems for measurement, recording and visualization of the operating parameters of engines tested;
- checking and adjusting the marine systems of measurement and automation of engines tested.

Calibration of sensors and measuring lines (both marine ones and used measurement and recording system) is carried out using appropriate calibrators. They allow, in case of pressure sensors, to produce a calibration pressure and in case of the voltage or current sensors to set the appropriate model signal. After calibration the characteristics (functions) of the individual measurement lines are developed, allowing the conversion of electrical signals from the sensors into units of measured physical quantities (pressure, temperature, speed). These characteristics, in modern measuring and recording systems, are introduced directly into the memory of a given system, and in case of older systems they are used during the preparation and analysis of measurement data.

The next stage of preparatory activities is connecting the measuring and recording system used for the study to systems and installations of examined propulsion system (of examined engines). When older measuring and recording systems (61MP and RE 1241 propulsion systems) are used for energy research, sensors independent of ship measurement systems were applied [15, 26]. The special splitters, connectors and switches mounted on marine systems and installations of the examined propulsion system enabled connecting the sensors (fig. 10). When modern systems of measurement and recording (frigates missile propulsion systems) are used for energy research, the system is connected to the marine measurement cards in the automation

module (FSEE), to which fed signals from various sensors of tested propulsion system are transferred (fig. 11). The configuration of systems in this way enables independent and parallel measurements of operating parameters of engines tested for the purpose of energy research, without any restrictions and disruption to marine measurement and control system due to working propulsion system, which is examined [27, 33].

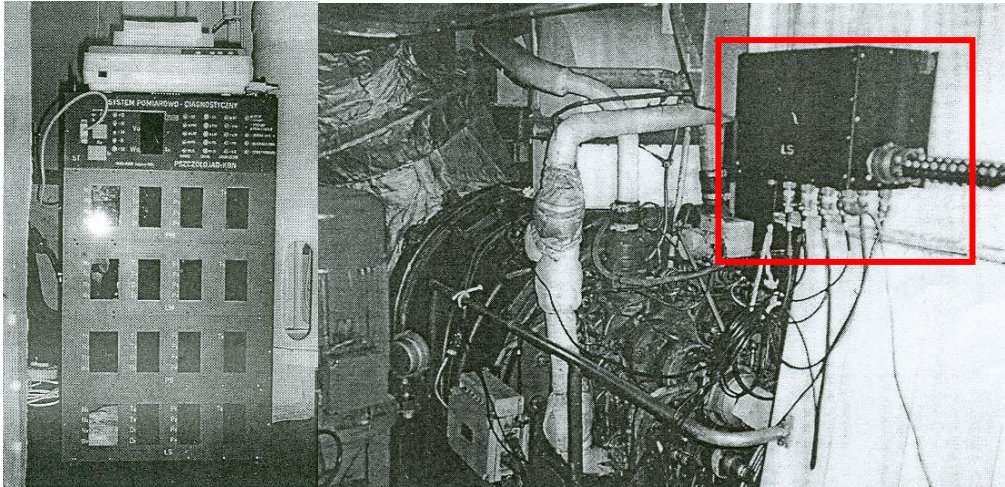

Fig. 10. Measuring and recording system 'PSZCZOŁOJAD' during energy research implemented on the ship [15]

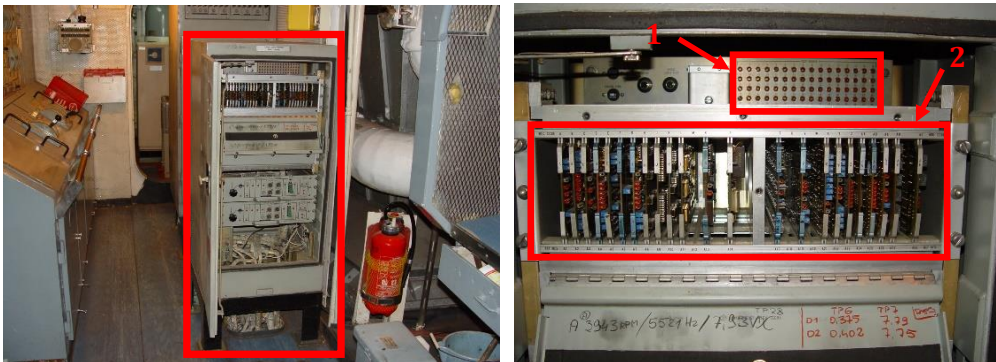

Fig. 11. Automation module of missile frigate propulsion system (FSEE): 1 — set of measurement signals outputs, 2 — measuring cards [33]

Before starting the energy research, the tests proving correctness regarding results of marine measurement systems and security as well as elements of automatic control system of tested engines. These tests are performed during the simulation research of engines that do not work, using testers (referencing-unit) specially constructed for this purpose [26, 27].

After completion of the preparatory activities, the energy research is possible. The examination of the start-up, idling and stopping the engine is performed when the ship is in the harbour, while the tests during work with load are carried out in real conditions — in the sea. During tests in the sea the simultaneous measurements of set energy states of all engines are performed, usually with speeds set by rotor gas generator in the range from idle to the nominal engine load. The engine load is changed in accordance with a program of research. During the measurement of operating parameters of the engine during start-up or stop, the measurements begin about 10 seconds prior to the planned process in order to accurately register the initial phase of the process, which is a reference for tests conducted later. Parameters during work with load are measured after about 1 minute of work of the engine at a given load. This is to stabilize the operating parameters of the previously conducted process of acceleration or deceleration of the engine. The following time intervals of engine operating parameters have been recorded [15, 26, 27, 33]:

- starting-up 120 s;
- with set load 20 s;
- override during stop 220 s.

Subsequently the summary and substantive analysis of measurement results of recorded operating parameters of tested engines are performed. In order to enable comparison of the characteristics of tested engines, as well as to relate them to different weather conditions, the results should be reduced to the so-called normalized conditions (standard reference state). Standard atmosphere conditions are defined by the following parameters: absolute pressure of 1 atm (101 325 Pa) and the absolute temperature 288.15 K [26, 27, 34]. Conversion relations used to normalize the values of the parameters measured or calculated are presented in table 2.

If the measurement results are developed, it is possible to determine the characteristics of engines and individual methods of diagnostic symptoms. Based on the compilation of the result it is also possible to verify the indications of marine control and measurement system and to determine uncertainties. If the value of the relative error exceeds 10%, it is assumed that a given measuring line is faulty.

Tab. 2. Conversion formulas used to reduce the value of the measured parameters to standard reference state: R — reduced, M — measured, 0 — ambient [34]

Parameter	Conversion formula
power	$P_R = P_M \cdot \frac{101325}{p_0} \cdot \sqrt{\frac{288.15}{T_0}}$
torque	$M_R = M_M \cdot \frac{101325}{p_0} \cdot \sqrt{\frac{288.15}{T_0}}$
speed	$n_R = n_M \cdot \sqrt{\frac{288.15}{T_0}}$
mass flow rate	$\dot{m}_R = \dot{m}_M \cdot \frac{101325}{p_0} \cdot \sqrt{\frac{T_0}{288.15}}$
temperature	$T_R = T_M \cdot \frac{288.15}{T_0}$
pressure (air, exhaust gas)	$p_R = p_M \cdot \frac{101325}{p_0}$
hourly fuel consumption	$B_{h_R} = B_{h_M} \cdot \frac{101325}{p_0} \cdot \sqrt{\frac{288.15}{T_0}}$
fuel pressure	$p_{fuel_R} = p_{fuel_M} \cdot \frac{288.15}{T_0} \cdot \left(\frac{101325}{p_0}\right)^2$

EQUIPMENT APPLIED FOR RESEARCH

Operating diagnosis of naval gas turbines in the field of energy research requires measurement parameters of the engine during its start-up and stop as well as within the entire range of loads. These parameters include: temperature, absolute pressure and mass flow of operating medium within characteristic sections, which correspond to nodal points regarding implementation of thermodynamic engine cycle. On the basis of recorded parameters it is possible to determine characteristics of the tested engine diagnostic systems that are set in the developed diagnostic methods. Schematic diagram along with control sections of the LM 2500 engine is presented in figure 12, while DR 76 and DR 77 engines — in figure 13.

Operating parameters of the engine type LM 2500 measured during the energy research are presented in table 3. Operating parameters of the engines type DR 76 and DR 77 measured during energy research are presented in table 4.

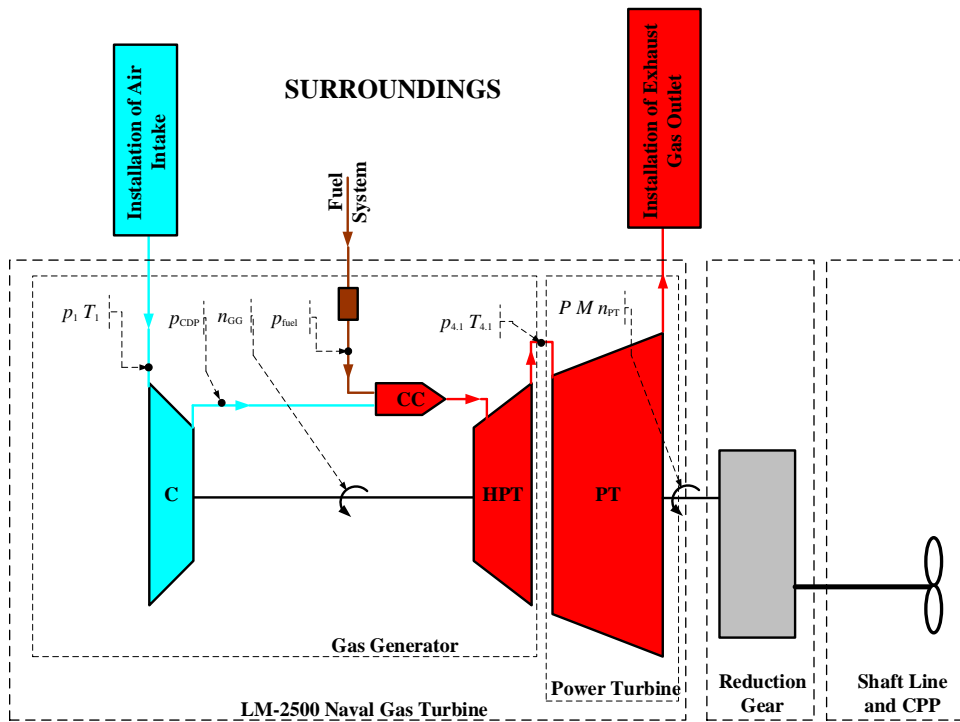

Fig. 12. Schematic diagram of naval gas turbine type LM 2500 along with the selected control sections [27]

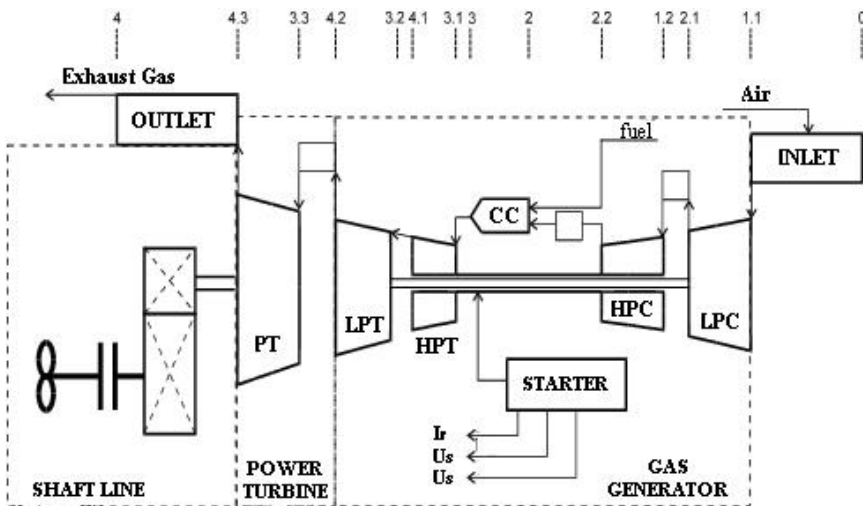

Fig. 13. Schematic diagram of naval gas turbine type DR 76 and DR 77 along with the selected control sections [26]

Tab. 3. Parameters of running engine type LM 2500 measured during the energy research [27]

Parameter designation	Measuring range	Description of the parameter
n_{GG}	0–12 000 RPM	gas generator speed
n_{PT}	0–5000 RPM	power turbine speed
p_1	0–16 psia	gas generator inlet air pressure
T_1	–40–150°F	gas generator inlet air temperature
p_{CDP}	0–300 psig	gas generator compressor discharge air pressure
π	0–20	compressor pressure ratio
$p_{4.1}$	0–75 psia	power turbine inlet exhaust gas pressure
$T_{4.1}$	0–2 000°F	power turbine inlet exhaust gas temperature
p_{fuel}	0–1 500 psig	fuel manifold pressure
M	0–35 000 ft·lbf	torque output
P	0–25 000 HP	power output

Tab. 4. Parameters of running engine type DE 59, DR 76, DR 77 measured during energy research [26]

Parameter designation	Measuring range	Description of the parameter
I_S	0–1000 A	starting current
U_S	0–60 V	starting voltage
U_F	0–60 V	field voltage
n_{LPC}	0–20 000 RPM	low pressure compressor speed
n_{HPC}	0–22 000 RPM	high pressure compressor speed
n_{PT}	0–10 000 RPM	power turbine speed
$p_{1.1}$	–0,4–0 bar	compressor inlet air pressure
p_{21}	0–6,0 bar	low pressure compressor outlet air pressure
$p_{2.2}$	0–16,0 bar	high pressure compressor outlet air pressure
p_{fuel}	0–100.0 bar	fuel manifold pressure
$t_{1.1}$	–70–180°C	compressor inlet air temperature
$t_{4.2}$	0–1000°C	power turbine inlet exhaust gas temperature
t_4	0–1000°C	power turbine outlet exhaust gas temperature

For the measurement, recording and visualization of the above-mentioned operating parameters, during the start-ups and stops of the engine, as well as during the work with load, the computer system for measuring and recording 'DIAGNOSER-3' was applied. This system was developed by a team from the Institute of Shipbuilding and Marine Propulsion of Polish Naval Academy. The measuring and recording system 'DIAGNOZER-3' is depicted in figure 14.



Fig. 14. Measuring and recording system 'DIAGNOZER-3' [15]

The limitation of system was the possibility to record parameters of only one engine. For this reason it was hard to ensure identical conditions for remaining engines during diagnostic tests. It also influenced the time and costs of the research.

The experiences concerning measurement and recording gained during using 'DIAGNOZER-3' were used to create computer system 'PSZCZOŁOJAD' used for measurement and recording. This system allowed to measure, record and visualize operating parameters of all engines that are part of 1241 RE as well as 61MP propulsion systems. This system allowed to measure the parameters of engines working simultaneously in the same conditions and to measure dynamics of work of marine propulsion system during manoeuvring. What is more, the time required for tests was shortened significantly. Its cost decreased as well. The measuring and recording system 'PSZCZOŁOJAD' is presented in figures 10 and 15.

The measuring and recording system 'PSZCZOŁOJAD' consisted of the following functional components [15]:

- a set of separate sensors for each engine;
- collect sensor box, separately for each engine;
- cable trays;
- measuring cassettes containing measuring amplifiers controlled by microcomputers equipped with measuring and digital display units;
- microcomputer controlling the operation of measuring system of the ship speed, astronomical time and supervising the work of four measuring cassettes used for printing and saving data;
- indicator of the ship speed;
- printer used to print results;
- set of RAM-disks used transfer measurement data from the measuring system to the main computer.

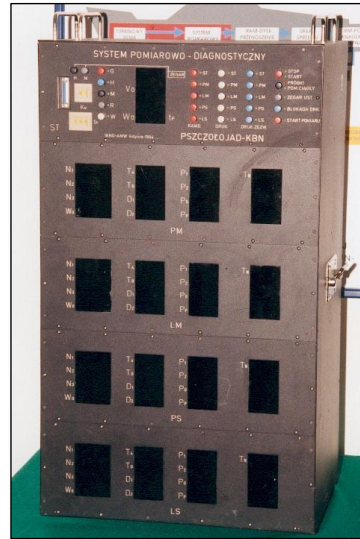

Fig. 15. Measuring and recording system 'PSZCZOŁOJAD' [15]

Despite the fact that the measuring and recording systems 'DIAGNOZER-3' and 'PSZCZOŁOJAD' perfectly fulfilled their roles, their limitation was that the measurement of operating parameters took place at the frequency of 1 Hz and there was no possibility to change it, which is standard option in modern measuring and recording systems. This limitation resulted in the fact that these systems could not be used for measuring operating parameters during acceleration and deceleration. In order to enable measurements of operating parameters of the above processes another system was built, which is 'TURBODYN'. It allowed simultaneous measurement, recording and visualization of the engine operation parameters at the frequency of 1 Hz, 2 Hz, 5 Hz and 10 Hz. The measuring and recording system 'TURBODYN' is presented in figure 16.

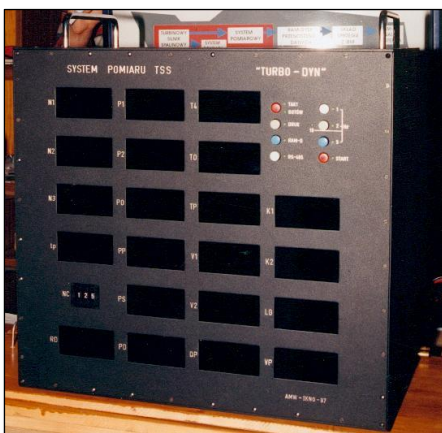

Fig. 16. Measuring and recording system 'TURBODYN' [15]

In the recent years a considerable development in measurement technology could be observed. Owing to this fact there are ample opportunities for the construction of new and universal measuring and recording systems. It became possible to purchase, unlike the past, completed specialized measuring and recording systems dedicated to various fields of technology. Therefore the basic diagnosing system of naval gas turbines has been modernised and developed in the recent years and a new measuring and recording system has been built on the basis of the purchased signal recorder DAS 1400 manufactured by SEFRAM [33, 34]. The recorder allows working with any standard PC with USB port, XGA, Ethernet, used as a port for data transmission. The main technical parameters of the recorder are:

- the number of analogue input channels max. 36;
- resolution capability 16 bit;
- the type of input signal voltage/current;
- input range +/- 5 V, 0-20 mA;
- processing accuracy +/- 0,1%, +/- 1 LSB;
- maximum sampling frequency 100 kHz;
- built-in hard disk 80 GB.

The developed system during the measurement stores the recorded values in the internal memory and after the measurement cycle transfers it to a laptop. The recorded parameters can be analysed with the use of specialized calculation programs. The view of the measuring and recording system DAS 1400 is shown in figure 17.



Fig. 17. The measuring and recording system Sefram DAS 1400 during energy research carried out on the ship [author's collection]

CONCLUSIONS

Operational system of the naval gas turbines developed by the Polish Navy is currently a multi-criteria system, based mainly on the technical condition strategy

and total operating costs. Operational diagnostics plays an important role in this system, in which energy research presented in the article is conducted. For the purpose of research, an underlying multi-symptom diagnostic system has been developed and implemented. The results of systematic diagnostic research allow for a conscious operation of the engines according to their technical condition. They are also used in operational decision-making processes regarding the ongoing maintenance, adjustments, repairs and, finally assessing the effects of the work performed.

Experience gained from systematic diagnostic research allow for confirming their validity and usefulness. This is particularly important at a time when the operation of the engines, including repairs, involves limited funds. The research made it possible to change the strategy of using the engines from the one based on the amount of work done to the technical condition strategy. In the recent years, this allows for extending the time between overhauls of both DR 76 and DR 77 engines and thus maintaining the vessels' fighting ability. Currently, in accordance with this strategy and with good effect, the LM 2500 engines have been operated on vessels with more than 38 years of service.

Knowledge and experience from diagnostic tests are also used in education and trainings of those responsible for the operation of this type of engines carried out at the Faculty of Mechanical and Electrical Engineering of the Polish Naval Academy in Gdynia. This is even more important given the fact that improper operation often leads to a serious damage affecting the fighting ability of a vessel and thus generates high and unexpected costs in the process of operation.

REFERENCES

- [1] Adamkiewicz A., Grządziela A., *Możliwość oceny niewyważenia zespołu wirnikowego okrętowego turbinowego silnika spalinowego na podstawie sygnałów drganiowych pozyskanych z łożyska nośnego*, "Tribologia", 2002, No. 1, pp. 57–70 [*Feasibility of unbalancing estimation of the gas turbine rotor using vibration signals from load bearing* — available in Polish].
- [2] Adamkiewicz A., *Relacje diagnostyczne w okrętowych turbinowych silnikach spalinowych*, 'Problemy Eksploatacji', 2001, No. 3, pp. 9–19 [*Diagnostic relationships in naval gas turbines* — available in Polish].
- [3] Adamkiewicz A., *Zagadnienia przedłużania okresu eksploatacji okrętowych turbinowych silników spalinowych*, 'Prace Naukowe Politechniki Warszawskiej. Mechanika' 2005, No. 211, pp. 7–17 [*The issue of extending operation time of marine gas turbine* — available in Polish].
- [4] Cempel C., Tomaszewski F., *Diagnostyka maszyn*, Międzyresortowe Centrum Naukowe Eksploatacji Majątku Trwałego, Radom 1992 [*Diagnostics of machines* — available in Polish].

- [5] Charchalis A. et al., *Opracowanie programu badań diagnostycznych i metod oceny dla weryfikacji (wydłużenia) okresu międzyremontowego silników turbinowych okrętu 1241 RE*, AMW, Gdynia 1991 [*Development of a program of diagnostic tests and evaluation methods for verification of intermittent naval gas turbines of ship 1241 RE* — available in Polish].
- [6] Charchalis A., *Diagnozowanie okrętowych silników turbinowych*, AMW, Gdynia 1991 [*Diagnosis of naval gas turbines* — available in Polish].
- [7] Charchalis A., Korczewski Z., *Badania diagnostyczne okrętowych turbinowych silników spalinowych na podstawie analizy zmian parametrów termogazodynamicznych*, XIV Międzynarodowe Sympozjum Siłowni Okrętowych, Szczecin 1992, pp. 63–71 [*Diagnostic tests of naval gas turbines based on analysis of changes in thermogasic parameters* — available in Polish].
- [8] Charchalis A., Korczewski Z., Dyson P. K., *Evaluation of operating conditions of the passages of naval gas turbines by gas path analysis*, The Institute of Marine Engineers, London 1996.
- [9] Charchalis A., Korczewski Z., *Metody diagnozowania okrętowych turbinowych silników spalinowych*, 'Przegląd Mechaniczny' 1997, No. 3–4, pp. 45–57 [*Methods of diagnosis of naval gas turbines* — available in Polish].
- [10] Charchalis A., Pojawa B., *Ocena stanu technicznego okrętowego turbinowego silnika spalinowego na podstawie badań momentu obrotowego przy rozruchu*, XXVIII Ogólnopolskie Sympozjum 'Diagnostyka maszyn', Węgierska Górka 2001, pp. 133–140 [*Assessment of the technical state of the naval gas turbine based on torque tests at start-up* — available in Polish].
- [11] Charchalis A., *Systemy pomiarowe wykorzystywane w diagnostyce okrętowych turbinowych silników spalinowych*, XV Międzynarodowe Sympozjum Siłowni Okrętowych, Gdynia 1993, pp. 73–81 [*Measurement systems used in the diagnostics of naval gas turbines* — available in Polish].
- [12] Charchalis A., *Wielosymptomowy system diagnozowania okrętowych turbinowych silników spalinowych*, 'Diagnostyka', 2004, Vol. 30/1, pp. 101–105 [*Multi-symptoms system of diagnosing of marine gas turbines* — available in Polish].
- [13] Charchalis A., Wirkowski P., *Badania eksploatacyjne okrętowych turbinowych silników spalinowych LM 2500*, 'Diagnostyka', 2004, Vol. 30/1, pp.106–110 [*Exploitation's researches of marine gasturbines LM 2500* — available in Polish].
- [14] Charchalis A., Wróblewski K., Włoch J., *Diagnostyka okrętowego turbinowego silnika spalinowego na podstawie eksploatacyjnych parametrów rozruchu*, XIV Międzynarodowe Sympozjum Siłowni Okrętowych, Szczecin 1992, pp. 73–85 [*Diagnostics of the naval gas turbine based on operational starting parameters* — available in Polish].
- [15] *Diagnostyka okrętowych turbinowych silników spalinowych*, AMW, Gdynia 1996, targeted project No. 148-23/C-SO/93 [*Diagnostics of naval gas turbines* — available in Polish].
- [16] *Dokumentacja techniczna i eksploatacyjna układu napędowego M15* [*Technical and operating documentation of the M15 propulsion system* — available in Polish].
- [17] *Dokumentacja techniczna i eksploatacyjna układu napędowego M3A* [*Technical and operating documentation of the M3A propulsion system* — available in Polish].
- [18] Grządziela A., *Metoda diagnozowania okrętowej linii wałów z zastosowaniem zidentyfikowanych modeli dynamicznych*, 'Zeszyty Naukowe AMW', 2008, No. 172A [*Diagnostic method for marine shaft lines using identified dynamic models* — available in Polish].

- [19] Grządziela A., *Metoda kontroli współosiowości elementów okrętowego układu napędowego z turbinowymi silnikami spalinowymi*, PhD thesis, AMW, Gdynia 1998 [A method of controlling the coaxiality of marine propulsion system components with naval gas turbines — available in Polish].
- [20] Korbicz J., Kościelny J. M., Kowalczyk Z., Cholewa W., *Diagnostyka procesów. Modele, metody sztucznej inteligencji, zastosowania*, WNT, Warszawa 2002 [Process diagnostics. Models, artificial intelligence, applications — available in Polish].
- [21] Korczewski Z., *Badania diagnostyczne w eksploatacji okrętowych turbinowych silników spalinowych*, 'Zeszyty Naukowe AMW', 2005, No. 2, pp. 67–88. [Diagnostic research in the operation of naval gas turbines — available in Polish].
- [22] Korczewski Z., *Badania procesu przyspieszania w konstrukcjach wielowirnikowych okrętowego turbinowego silnika spalinowego*, XVII Międzynarodowe Sympozjum Siłowni Okrętowych, Szczecin 1995, pp. 93–105 [Research on the acceleration process in multi-rotor constructions of a naval gas turbine — available in Polish].
- [23] Korczewski Z., *Identyfikacja procesów gazodynamicznych w zespole sprężarkowym okrętowego turbinowego silnika spalinowego dla potrzeb diagnostyki*, 'Zeszyty Naukowe AMW', 1999, No. 138A [Identification of gas-dynamic processes in the compressor assembly of a naval gas turbine for diagnostic purposes — available in Polish].
- [24] Korczewski Z., *Metoda diagnozowania części przepływowej okrętowych turbinowych silników spalinowych w eksploatacji*, PhD thesis, AMW, Gdynia 1992 [Method of diagnosis of flow parts of naval gas turbines in operation — available in Polish].
- [25] Korczewski Z., *Simulation model of the compressors configuration of naval gas turbine for diagnostic purposes*, 'Marine Technology Transactions. Technika Morska', 1997, Vol. 8.
- [26] *Metodyka badań okrętowych turbinowych silników spalinowych typu DR76 i DR77 użytkowanych w MW RP*, praca zbiorowa, AMW, Gdynia 2006 [Methodology of research of naval gas turbines DR76 and DR77 used in Polish Navy, group work — available in Polish].
- [27] *Metodyka badań okrętowych turbinowych silników spalinowych typu LM 2500 użytkowanych w MW RP*, praca zbiorowa, AMW, Gdynia 2006 [Methodology of research of naval gas turbines LM 2500 used in Polish Navy, group work — available in Polish].
- [28] *Metodyka oceny współosiowości elementów transmisji momentu obrotowego w okrętowych układach napędowych*, AMW, Gdynia 1995–1998, research project No. 0 T00A 009 16 [Methodology for assessing the coaxiality of torque transmission components in marine propulsion systems — available in Polish].
- [29] Mironiuk W., *Ocena stanów awaryjnych układów łożyskowych turbinowych silników spalinowych*, PhD thesis, AMW, Gdynia 1995. [Assessment of emergency conditions of bearing systems of naval gas turbines — available in Polish].
- [30] Moczulski W., *Diagnostyka techniczna. Metody pozyskiwania wiedzy*, Publ. Silesian University of Technology, Gliwice 2002 [Technical diagnostics. Knowledge acquisition methods — available in Polish].
- [31] Niziński S., Michalski R., *Diagnostyka obiektów technicznych*, Publ. University of Warmia and Mazury, Olsztyn 2001 [Diagnostics of technical objects — available in Polish].
- [32] *Ocena stanu technicznego okrętowych turbinowych silników spalinowych w oparciu o badania ich cech dynamicznych*, AMW, Gdynia 1995–1998, research project No. 9T12D00811 [Assessment of the technical state of naval gas turbines based on their dynamic characteristics — available in Polish].

- [33] *Opracowanie systemu diagnostycznego okrętowych turbinowych silników spalinowych fregat wdrażanych w Marynarce Wojennej RP*, AMW, Gdynia 1995–1998, research project No. 0 T00A 062 19 [Development of a diagnostic system for naval gas turbines of frigates deployed in the Polish Navy — available in Polish].
- [34] Pojawa B., *Characteristics Determination of LM-2500 Naval Gas Turbine in Aspect of Energy Modeling and Simulations*, 'Solid State Phenomena', 2015, Vol. 236, pp. 169–179.
- [35] Pojawa B., *Metoda diagnozowania układu rozruchowego okrętowego turbinowego silnika spalinowego*, PhD thesis, AMW, Gdynia 2003 [Method of diagnosis of the start-up system of a naval gas turbine — available in Polish].
- [36] *Sprawozdania z badań diagnostycznych turbinowych silników spalinowych eksploatowanych na okrętach MW RP*, AMW, Gdynia 1985–2016, research and service [Reports on diagnostic tests of naval gas turbines operating in Polish Navy — available in Polish].
- [37] Szczeciński S., Balicki W., *Diagnozowanie lotniczych silników turbinowych*, Biblioteka Naukowa Instytutu Lotnictwa, Warszawa 2001 [Diagnosing aircraft turbine engine — available in Polish].
- [38] *Technical, Manual and Organizational Level Maintenance — LM-2500 propulsion gas turbine module of propulsion system of Oliver Hazard Perry class frigate FFG-9*, Marine and Industrial Engines and Services Division, General Electric Company, Cincinnati, Ohio 2003.
- [39] Włoch J., *Diagnozowanie okrętowych turbinowych silników spalinowych na podstawie wielkości charakteryzujących przebieg rozruchu i zatrzymania*, PhD thesis, AMW, Gdynia 1994 [Diagnosing naval gas turbines on the basis of parameters characterizing the start-up and stop process — available in Polish].
- [40] Żółtowski B., *Elementy racjonalnej eksploatacji systemów technicznych*, 'Inżynieria i Aparatura Chemiczna', 2012, No. 2, pp. 34–36 [Elements of rational use of technical systems — available in Polish].
- [41] Żółtowski B., *Podstawy diagnostyki maszyn*, Publ. University of Technology and Agriculture, Bydgoszcz 1996 [Fundamentals of machine diagnostics — available in Polish].
- [42] <http://www.3fo.mw.mil.pl> [access 09.11.2016].

SYNTEZA DIAGNOSTYKI EKSPLOATACYJNEJ OKRĘTOWYCH TURBINOWYCH SILNIKÓW SPALINOWYCH EKSPLOATOWANYCH W MARYNARCE WOJENNEJ RP

STRESZCZENIE

W artykule przedstawiono całokształt badań energetycznych realizowanych przez Akademię Marynarki Wojennej na potrzeby diagnostyki eksploatacyjnej okrętowych turbinowych silników spalinowych eksploatowanych w Marynarce Wojennej RP. Przedstawiono cel i metodykę badań, identyfikację obiektu badań oraz aparaturę badawczą, wyniki będą zaprezentowane w kolejnym artykule *Analiza*

parametrów eksploatacyjnych okrętowych turbinowych silników spalinowych. Na okrętach MW RP w latach 1983–2003 eksploatowane były cztery typy okrętowych turbinowych silników spalinowych: DE 59, DR 76, DR 77 i LM 2500. Obecnie, od 2013 roku, w bieżącej eksploatacji znajdują się cztery silniki typu LM 2500 występujące na fregatach rakietowych typu 'Oliver Hazard Perry'. W najbliższej perspektywie czasowej do eksploatacji wejdzie kolejny silnik typu LM 2500 wraz z okrętem patrolowym projektu 661M. Systematycznym nadzorem eksploatacyjnym, w ramach badań energetycznych, objęty jest proces rozruchu silników, ich pracy na biegu jałowym oraz w całym zakresie zmienności obciążeń, jak również proces zatrzymania silników.

Słowa kluczowe:

diagnostyka techniczna, okrętowy turbinowy silnik spalinowy, stan techniczny, silnik LM 2500.