

Volodymir KONOVAL\*  
Roman PRYTULA\*\*  
Oleksij SKRYPNYK\*\*\*

## STATIC STABILITY ANALYSIS OF POWER SYSTEMS

The developed modal method for analyzing oscillating static stability of power systems is based on eigenvalues and eigenvectors. As a mathematical model to the study we use a system of linearized differential equations that describe the behaviour of synchronous machines and their excitation systems during minor disturbances. This approach allows us to analyse the static stability of large power systems, evaluate stability margins, degree of damping modes, and set adjustment mechanism for mode parameters to improve mode stability. We investigated the impact of generator excitation system replacement on stability of Ukraine's power system. The suggested modal analysis is implemented in the DAKAR software suite [1].

KEYWORDS: static stability, power system, modal analysis

### 1. INTRODUCTION

The current stage of power system development is marked by increasing number of systems with weak interconnections and replacement of outdated automatic control systems with new modern ones. This causes transient processes in the dynamic objects to display new characteristics that form complex local and systemic system, untypical of simple-structure systems. Low frequency oscillations are usually associated with low attenuation and underdamping of system parameters and may create instability of accumulations of power system clusters. To avoid this, power system operations should follow certain restrictive guidelines. Electromechanical transients that occur under minor and serious disturbances are related not only to change of mode electric parameters, but also to processes in generator's mechanical section/hardware. The main equation covering both electrical and mechanical parameters is the equation of generator rotor float.

The modal method is the most modern method currently used to analyse power system stability. This method involves decomposition of power system

---

\* Lviv Polytechnik National University.

\*\* Ivan Franko National University of Lviv.

\*\*\* Firm "ELEKS Software", Lviv.

free oscillations to separate components. Considering complex systems, the process of merging power systems is the most difficult to simulate. First, the main problem is the size of such system as it consists of hundreds of generators connected with thousands of power lines, bushes, and hundreds of load centres. Secondly, complex nature of network physical processes causes problems due to physical values with different time dynamics (electrical changes usually occur faster than mechanical change of generator rotor position). Therefore, creating an acceptable model for analysis of power system stability requires several simplifications.

## 2. STATIC STABILITY ANALYSIS METHOD

### 2.1. Mathematical model

The power system under study consists of  $N$  synchronous machines interconnected by huge quantity of connections. As for the mathematical model for study of oscillating static stability for power system, we use a system of linearized differential equations that describe behaviour of system oscillations caused by minor disturbances. For this approach, the unknown values are the oscillation modes parameters that can be used to control power system stability. To calculate electromechanical transients, we use a model of synchronous machine that is described by the following differential equations [2-4]:

$$\begin{aligned}
 \frac{d\delta}{dt} &= s \\
 \frac{ds}{dt} &= \frac{1}{T_j} \left[ \frac{P_{g.nom} \mu_{\Sigma} P_s}{1+s} - \frac{E_q'' i_q + E_d'' i_d}{1+s} \right] \\
 \frac{dE_q''}{dt} &= \frac{1}{T_{d_0}'} \left[ E_{qe} - E_q'' - (x_d - x'') i_d \right] \\
 \frac{dE_d''}{dt} &= \frac{1}{T_{q_0}'} \left[ E_{de} - E_d'' + (x_q - x'') i_q \right] \\
 \frac{dE_{qe}}{dt} &= \frac{1}{T_{qe}} \left[ E_{qe}^0 - E_{qe} + U_r \right] \\
 \frac{dU_r}{dt} &= \frac{1}{T_r} \left[ -U_r + k_{0U} (U_g - U_g^0) + k_{1U} \frac{dU_g}{dt} + k_{1r} \frac{dE_g}{dt} + k_{0f} s + k_{1f} \frac{ds}{dt} \right]
 \end{aligned} \tag{1}$$

where:  $\delta$  – displacement angle of generator rotor against synchronous axis;  
 $s$  – generator slip;  $E_q''$  – cross-axis component of generator EMF for  $q$  axis;

$E_d''$  – direct-axis component of generator EMF for  $d$  axis;  $E_{qe}$  – excitation voltage;  $U_r$  – output voltage of excitation regulator;  $T_j$  – inertia time constant of rotating elements;  $P_{g.nom.}$  – generator (turbine) nominal power;  $\mu_\Sigma$  – full relative power reached by generator;  $p_s$  – steam pressure before turbine;  $i_d, i_q$  – projection of currents on direct and cross axes;  $T_{d_0}', T_{q_0}'$  – transient time constants for direct and cross axes;  $E_{qe}, E_{de}$  – EMF of excitation for both axes;  $x_q, x_d$  – synchronous reactances for direct and cross axes;  $x''$  – subtransient instantaneous reactance;  $T_{qe}$  – exciter time constant;  $E_{qe}^0$  – EMF of generator excitation obtained during previous calculation of power flows;  $T_r$  – time constant of excitation regulator;  $k_{0U}, k_{1U}, k_{1r}, k_{0f}, k_{1f}$  – gain coefficient for separate channels of control (deviation of voltage derivative, rotor current derivative, and frequency deviation and derivative).

Hence, in our model, each generator is characterized by the following unknown values:  $\delta, s, E_q'', E_d'', E_{qe}, U_r$ , and the rest of values are considered as input data. The last equation of the system (1) can be modified according to the excitation system type [5-8].

## 2.2. Eigenvalues and eigenvectors

We analyse power system stability using Lyapunov's method [9] that is based on the eigenvalues and corresponding eigenvectors of the characteristic matrix  $\mathbf{A}$ . Matrix  $\mathbf{A}$  is built for the entire power system that consists of  $N$  generators each of which is described by the system of differential equations (1). The eigenvalues are obtained from the condition

$$\det[\mathbf{A} - \lambda \cdot \mathbf{I}] = 0 \quad (2)$$

where  $\lambda$  – matrix  $\mathbf{A}$  eigenvalues,  $\mathbf{I}$  – unity matrix. Matrix eigenvalues in general are complex numbers. The solution for such system of linear algebraic equations is  $6N$ -values

$$\lambda_i = \sigma_i + j\omega_i,$$

where  $i = 1, \dots, 6N$ ,  $\sigma_i$  – real part of eigenvalue,  $\omega_i$  – imaginary part of eigenvalue. To analyse power system stability, it will suffice to take into account eigenvalues located in the upper complex semiplane, because power system conditions in the lower complex semiplane can be obtained by mirroring upper semiplane conditions. The eigenvectors are determined from the eigenvalues and functions equation for particular eigenvalue:

$$\mathbf{A} \cdot \psi_i = \lambda_i \cdot \psi_i, \quad (3)$$

where  $\psi_i$  – eigenvector. We are interested only in nontrivial solutions for the equation. For this approach, the eigenvector components are complex numbers which module determines range of parameters influence degree  $\delta$ ,  $s$ ,  $E_q''$ ,  $E_d''$ ,  $E_{qe}$ ,  $U_r$  for each generator in creation of a condition. The solution of equation (2) is searched for using numerical methods: first, we write matrix  $\mathbf{A}$  in the form of upper or lower Hessenberg matrix, and then, we use the  $QR$ -algorithm.

### 2.3. Method for analysing static stability

In such mathematical model, the imaginary part of eigenvalue determines oscillation frequency of power system modes, and the real part is related to the stability coefficient and system mode damping. Power system stability is determined with the sign of eigenvalue real part of characteristic matrix  $\mathbf{A}$  for the system of linearized differential equations: if the real part of all eigenvalues is negative  $Re \lambda_i < 0$ , then the power system is statically stable; and if at least one eigenvalue is  $Re \lambda_i \geq 0$ , then the system is statically unstable. Power system stability coefficient (margin) is determined as maximum negative value of the real part of matrix  $\mathbf{A}$  eigenvalues:

$$\zeta = \min(|\sigma_i|), i = 1, \dots, 6N \quad (4)$$

It should be mentioned that power system stability coefficient is searched for the entire power system, that is for the whole collection of all nodes. For further studies, we consider the mode stability margin to be the module of eigenvalue's real part. When the power system is stable, the damping coefficient should be investigated because it can be used to determine dangerous oscillating modes of systemic parameters. The damping coefficient is related to the real and imaginary parts of eigenvalue as follows:

$$\xi = -\frac{\sigma}{\sqrt{\sigma^2 + \omega^2}}. \quad (5)$$

Since eigenvalues are characteristic of differential equations system that describes power system oscillation modes in linear approximation, this mechanism can be considered as reasonable to show system response during different minor disturbances, in particular, to analyse oscillating static stability. To illustrate such power system stability display and analysis, it is convenient to divide power system into separate zones of low-frequency systemic oscillations: 5%, 10%, 15%, and the like. If the eigenvalue is in the 5% damping zone, this means a rather slow oscillation damping of mode systemic parameters which may be dangerous for power system's stability.

Eigenvectors are another important characteristic of the system of differential equations. They are used to determine the degree of generator parameters impact on the formation of power system mode (condition). In particular, when studying

eigenvectors it is possible to identify generator groups inclined to different oscillations and set adjustment mechanism for mode parameters to improve mode stability. It is necessary to yield oscillation frequencies when analysing oscillating static stability. In general, two oscillation zones are defined based on frequency: intersystem oscillations with frequency of 0.1–0.7 Hz, intergenerator and interstation oscillations with frequency of 0.7–2 Hz.

### 3. STATIC STABILITY ANALYSIS OF UKRAINIAN POWER SYSTEM

To illustrate model analysis, we investigate how the stability of Ukraine’s power system is impacted by replacement of TG-4 excitation system change for Rivne NPP block No. 2. Figure 1 presents the block scheme of the new SEMI Exciter AEG excitation system, where  $K_I$  – gain coefficient for current channel;  $T_I$  – time constant for current channel,  $K_U$  – gain coefficient for voltage channel,  $T_U$  – time constant for voltage channel,  $K_Q$  – gain coefficient for Q,  $K_T$  – gain coefficient for terminal current limitation channel,  $T_T$  – time constant for terminal current limitation channel,  $E_{FD}$  – excitation output voltage,  $E_{FD,min}$  – excitation minimum voltage,  $E_{FD,max}$  – excitation maximum voltage,  $I_{FD}$  – excitation current,  $I_{FD,min}$  – excitation maximum current,  $PSS$  – system stabilizer,  $V_{REF}$  – set voltage of voltage control,  $V_C$  – output voltage of transducer terminal,  $Q$  – reactive power,  $I_T$  – synchronous generator terminal current,  $I_T Limit$  – terminal current limitation.

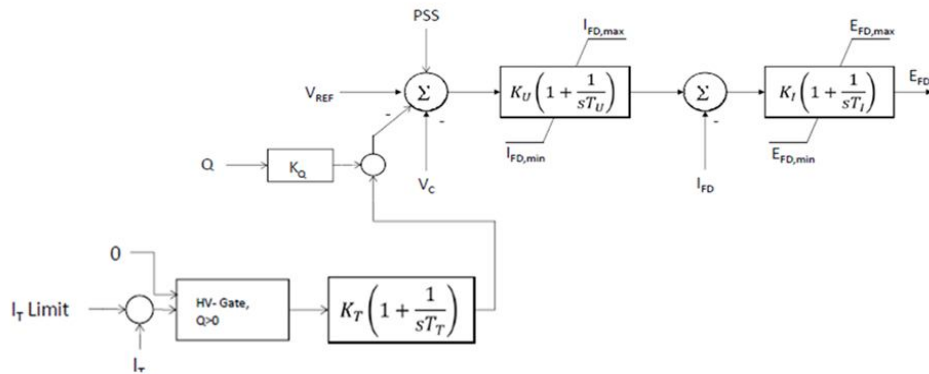

Fig. 1. Mathematical model of SEMI Exciter static excitation system for TG-4 (block 2) synchronous generator

Figure 2 shows part of Ukraine’s power system conditions based on modal method where arrows indicate condition movement under different excitation systems installed at TG-4 of Rivne NPP block No. 2: old conditions are marked

with green dots and the new excitation system is marked with red dots. Each dot in the figure corresponds to a certain possible condition of power system under certain frequency. To various extents, the position of each point is influenced by all power system generators with different impact degree. Power system has the oscillating static stability when all system points are located at the left of cross axis. Power system is considered as damped enough if all its conditions lay outside of the 5% damping zone. If a power system condition is within the 5% zone, this may cause mode oscillation and destroy oscillating static stability. By controlling generators parameters, you can change power system conditions, which means changing power system stability as required. Power system stability coefficient equals  $\zeta = 0.203551$  and corresponds to the condition with real part of  $-0.203551$  and oscillation frequency of 2.16 Hz. This condition is also characterized by the lowest damping coefficient of power system mode.

For example, let's analyse the condition with real part of  $-0.229119$  and frequency 0.45 Hz. The table 1 presents results of eigenvalues and eigenvectors calculation for old excitation system for AEC at the generator TG-4 of block No. 2 Rivne NPP (9904). The next table 2 shows presents results of eigenvalues and eigenvectors calculation for new excitation system for AEC at the generator TG-4 of block No. 2 Rivne NPP (9904) (SEMI Exciter AEG) with  $K_U=10$ ,  $K_I=4$  as parameters of excitation system. The tables 1 and 2 have the following shortings gen. name – generator name,  $w_j^{i1}$  – impact degree of generator rotor  $i$  displacement angle on the eigenvalue  $j$  formation;  $w_j^{i2}$  – impact degree of generator  $i$  slip on the eigenvalue  $j$  formation;  $w_j^{i3}$  – impact degree of generator  $i$  EMF direct-axis component on the eigenvalue  $j$  formation;  $w_j^{i4}$  – impact degree of generator  $i$  EMF cross-axis component on the eigenvalue  $j$  formation  $w_j^{i5}$  – impact degree of generator  $i$  excitation voltage on the eigenvalue  $j$  formation;  $w_j^{i6}$  – impact degree of generator  $i$  excitation regulator output voltage on the eigenvalue  $j$  formation;  $w_j^i$  – impact degree of generator  $i$  on the eigenvalue  $j$  formation. Results show the decrement of generators impact degree including the generator studied. The largest impact on the formation of this condition with the degree of 0.089536 (9%) has the Zaporizhzhya NPP generator of block No. 2 (9311), and the impact degree of generator TG-4 of Rivne NPP block No. 2 (9904) is 0.038939 (4%). The impact degrees of other generators are almost identical. Therefore, we should expect explicit movement of this condition after excitation system change. After the new excitation system is installed (see table 1), the impact degree of generator of Zaporizhzhya NPP block No. 2 (9311) on the formation of the studied condition is 0.089553 (increased by 0.02% of initial

value), and TG-4 of Rivne NPP block No. 2 (9904) –  $0.033004$  (decreased by 15% of initial value). The installation of new excitation system decreased impact of generator TG-4 of Rivne NPP block No. 2 (9904) on the formation of this condition by increasing impact of other generators. With the new excitation system, condition stability margin increased by 5%. New excitation system improves intersystem oscillations under the frequency of  $0.45$  Hz.

As shown above, we obtained a mechanism to control system parameters: by changing excitation system parameters, we can determine their optimal values that ensure the largest stability margin for certain condition and entire power system. Here is an example. Let's use another set of parameters for the new excitation system, such as  $K_U=2$ ,  $K_I=4$ . The table 2 shows that third and fourth generator parameters have the largest impact. In other words, these are generators EMF direct- and cross-axis components. In reality, we can directly influence the output voltage of excitation regulator by changing the  $K_U$  and  $K_I$  parameters. As for the rest of excitation system parameters  $\delta$ ,  $s$ ,  $E_q''$ ,  $E_d''$ ,  $E_{qe}$  we can change them only indirectly by changing excitation regulator parameters. For the new excitation system parameters set  $K_U = 2$  and  $K_I = 4$ , the impact degree of studied generator on mode formation is  $0.019515$  (2%) while the stability margin decreased by 7% of the value when  $K_U = 10$  and  $K_I = 4$ . Hence, we can deduce that  $K_U = 10$  and  $K_I = 4$  parameters set is better than  $K_U = 2$  and  $K_I = 4$  set.

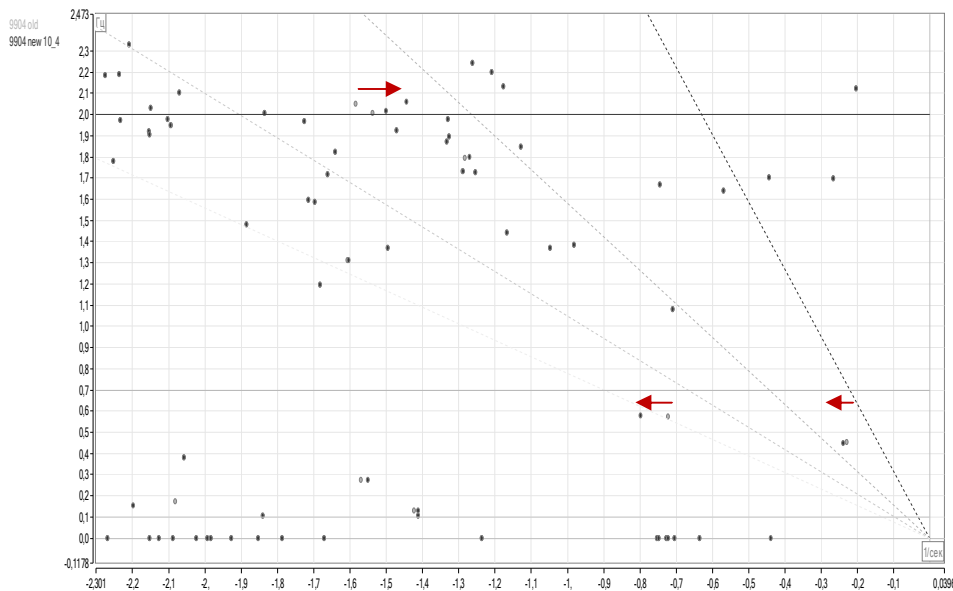

Fig. 2. Movement of Ukrainian united power system under different excitation system types for the TG-4 of Rivne NPP block No. 2

Table 1. Generators impact degree on the studied condition for the old excitation system and AEC at TG-4 generator of Rivne NPP block No. 2

gen. name	9311_G:6.1 Zaporizhzhya NPP	9312_G:b.2 Zaporizhzhya NPP	9821_G:b.1 Ladyzhyn NPP	9903_G: TG 3 Rivne NPP	9904_G: TG4 Rivne NPP
$w_j^{i1}$	0.000257	0.000257	0.000196	0.001436	0.001436
$w_j^{i2}$	0.002078	0.002078	0.001589	0.011619	0.011619
$w_j^{i3}$	0.067933	0.067933	0.040304	0.013241	0.013241
$w_j^{i4}$	0.007476	0.007476	0.019832	0.002400	0.002400
$w_j^{i5}$	0.005526	0.005526	0.005794	0.003618	0.003618
$w_j^{i6}$	0.006266	0.006266	0.006569	0.006625	0.006625
$w_j^i$	<b>0.089536</b>	<b>0.089536</b>	<b>0.074283</b>	<b>0.038939</b>	<b>0.038939</b>

Table 2. Generators impact degree on the studied condition for the new excitation system and AEC at TG-4 generator of Rivne NPP block No2

gen. name	9311_G:b.1 Zaporizhzh ya NPP	9312_G:b.2 Zaporizhzh ya NPP	9821_G: b.1 Ladyzhyn NPP	9822_G: b.2 Ladyzhyn NPP	9903_G: TG 3 Rivne NPP	9904_G: TG 4 Rivne NPP
$w_j^{i1}$	0.000262	0.000262	0.000209	0.000365	0.001517	0.000853
$w_j^{i2}$	0.002070	0.002070	0.001658	0.002893	0.012010	0.006756
$w_j^{i3}$	0.068084	0.068084	0.042098	0.020048	0.013518	0.009641
$w_j^{i4}$	0.007634	0.007634	0.021021	0.009903	0.002367	0.008341
$w_j^{i5}$	0.005411	0.005411	0.005919	0.003052	0.003568	0.002645
$w_j^{i6}$	0.006092	0.006092	0.006664	0.003436	0.006429	0.004767
$w_j^i$	<b>0.089553</b>	<b>0.089553</b>	<b>0.077569</b>	<b>0.039698</b>	<b>0.039409</b>	<b>0.033004</b>

#### 4. CONCLUSION

The suggested modal method based on eigenvalues and eigenvectors allows analysing static stability of huge power systems, evaluating stability margin and mode damping degree, and setting adjustment mechanisms for mode parameters to improve mode stability. We determined that installation of new SEMI Exciter AEG excitation system with  $K_U = 10$  and  $K_I = 4$  parameters set at TG-4 generator of Rivne NPP improves intersystem oscillations at 0.45 Hz.



**REFERENCES**

- [1] [www.dakar.eleks.com](http://www.dakar.eleks.com)
- [2] Lokhanin Ye., and Mamikonyants L., More on the mathematical modelling of synchronous and asynchronized machines when analyzing processes in power systems – *Elektrichestvo*, Number 2, 14 – 22, 2000.
- [3] Lokhanin Ye., Simplification of equations of synchronous machines – *Elektrichestvo*, Number 4, 18 – 29, 2000.
- [4] Skrypnyk O., Analysis Methods and Simulation of Electric Power System Regimes and Processes – State University "Lvivska Polytechnica", Lviv, 1999.
- [5] IEEE Committee Report, Computer Representation System –IEEE Transactions on Power Apparatus and Systems, Volume PAS-87, Issue 6, 1460–1464, 1968.
- [6] IEEE Committee Report, Excitation System Models for Power System Stability Studies – IEEE Transactions on Power Apparatus and Systems, Volume PAS-100, Issue 2, 494–509, 1981.
- [7] IEEE Power Engineering Society, IEEE Recommended Practice for Excitation System Models for Power System Stability – IEEE Std, 421.5<sup>TM</sup>, 2006.
- [8] Ferguson R., Herbst H. and Miller R., Analytical Studies of the Brushless Excitation System – *AIEE Trans.*, Part III, 961-970, 1957.
- [9] Eremia M, Shahidehpour M, Handbook of electrical power system dynamics: modeling, stability, and control, Wiley – IEEE Press, Canada, 2013.