

Elleuch Mounir

Ben Bacha Habib

Masmoudi Faouzi

National school of engineering, Sfax, Tunisia

Improvement of manufacturing cells with unreliable machines

Keywords

manufacturing cell, intercellular transfer, markov chains, availability, simulation, performances

Abstract

The performance of cellular manufacturing (CM) is conditioned by disruptive events, such as failure of machines, which randomly occur and penalize the performance of the cells and disturb seriously the smooth working of the factory. To overcome the problems caused by the breakdowns, we develop a solution, based on the principle of virtual cell (VC) and the notion of intercellular transfer that can improve performances of the system. In this context, we use an analytical method based on Markov chains to model the availability of the cell. The found results are validated using simulation. The proposed solution in this paper confirmed that it is possible to reduce the severity of breakdowns in the CM system and improve the performances of the cells through an intercellular transfer. Simulation allowed a validation of the analytical model and showed the contribution of the suggested solution.

1. Introduction

Group technology (GT) is a manufacturing philosophy that has attracted a lot of attention because of its positive impacts in the batch-type production. Cellular manufacturing (CM) is an application of GT to manufacturing. It has emerged in the last two decades as an innovative manufacturing strategy that collects the advantages of both product and process oriented system for a medium-volume and medium-variety production. By applying the GT concept and CM system, manufacturing companies can achieve many benefits including reduced set-up times, reduced work-in-process, less material handling cost, higher throughput rates.

The performance of a cellular manufacturing system is conditioned by disruptive events (e.g., failures of machines) that randomly occur and penalize the performance of the system. Therefore, equipment that falls in breakdown generates eventually the interruption of the whole cell. Consequently, failure of the machine implies total loss of cell capabilities and it leads to the partial deterioration of the performance of the total system [1]. Therefore, the application of an

efficient strategy against these perturbations permits to improve the performance of those production systems. Few researches can be found related to the effect of the failure on the operation of CM system. Some of these discussed the efficient maintenance politics to improve the performance of the cellular manufacturing [1], [4] and [5]. Others developed new coefficients of similarity that consider a number of alternative ways during the machine breakdown [3].

This paper is concerned with problems of the availability of production cells facing random event due to an internal disruption of breakdown-machine type. It uses intercellular transfer as a policy to surmount this type of disruption. The proposed solution is based on the external routing flexibility: the ability to release parts to alternative cell. This policy is assessed through modelling of the production cell and its simulation with Arena software.

The remainder of this paper is organized as follows. In section 2 and 3, we formulate a comprehensive idea of intercellular transfer policy and we give the method for modelling the availability of the cell. Section 4 presents a comprehensive simulation model to validate the analytical model and evaluate the policy of

intercellular transfer. Finally, we recapitulate in section 5 the main conclusion of this work and we make recommendations for future research.

2. Description of the manufacturing cell

The shop consists of several machines that are grouped into different group technology cells operating in a static environment. Each cell is characterized by a classically structured flow line with (m) machines in series. These machines are unreliable, with operation dependent failures, and have a constant failure and repair rates λ_i and μ_i ($i = 1 \dots m$).

In this section, we introduce the parameters that characterize the behaviour of machines in a material flow model. Each machine M_i is characterized by three parameters:

- Average utilization rate Tu_i : This is the rate at which material flows gets processed through the machine M_i in the absence of failure.
- Average failure rate λ_i : This is the rate at which machine M_i fails when working at its maximum processing rate (100%).
- Average repair rate μ_i : This is the rate at which machine M_i gets repaired if it is down for a failure.

Using these parameters Tu_i , λ_i and μ_i , we can define the basic parameters of an isolated machine M_i :

- There is the average failure rate $\lambda_{i.Fc}$: This is the rate at which machine M_i fails when working at its utilization rate Tu_i .

$$\lambda_{i.Fc} = \lambda_i \cdot F_c \quad (1)$$

where

$$F_c = Tu_i. \quad (2)$$

- Isolated efficiency $A_i(\infty)$: that is the average proportion of time during which machine M_i would be operational. It is equal to the steady-state availability. $A_i(\infty)$ is defined in terms of parameters as follows:

$$A_i(\infty) = \frac{\mu_i}{\lambda_{i.Fc} + \mu_i}. \quad (3)$$

If the single machine, whose parameters are defined as above, were part of a production cell, additional parameters would be needed to characterize it. These parameters are given below.

- Average utilization rate Tu_i^* : in a production cell environment, a cell allows the manufacturing of family products that made of several types, which forms various batches, having different sequences of operations. We regard $Tu_{i,k}$ as the utilisation rate of the machine M_i during the manufacture of the batch k .

Therefore to determine the machine utilisation rate, it is enough to calculate its utilisation rate during the manufacturing of family products (various batches allocated to cell) without taking account of the effect of the breakdowns of the other machines. This rate is given by the following expression:

$$Tu_i = \frac{\sum_{k=1}^n Tu_{i,k} \cdot t_{i,k}}{tt_i} \quad (4)$$

with:

- $t_{i,k}$: the time put by the machine (i) to manufacture the batch k ,
- tt_i : the total time to manufacture family products on the machine (i),
- n : number of batches treated in manufacturing cell.

Taken account of the condition which says that the breakdown of a machine generates the interruption of the cell, i.e. that we do not have a breakdown at the same time inside a cell; the utilization rate will be approximated by the following expression:

$$Tu_i^* = Tu_i \cdot E, \quad (5)$$

- where E is the efficiency of the cell given by the following expression [2]

$$E = \frac{1}{1 + \sum_{i=1}^m \frac{\lambda_{i.Fc}}{\mu_i}}. \quad (6)$$

- Failure rate $\lambda_{i.Fc}^*$: This is the rate at which machine M_i fails when it work in a cell.

$$\lambda_{i.Fc}^* = \lambda_i \cdot F_c^* \quad (7)$$

where

$$F_c^* = Tu_i \cdot \frac{1}{1 + \sum_{\substack{j=1 \\ j \neq i}}^m \frac{\mu_j}{\lambda_{j.Fc}}}, \quad (8)$$

with: m represents the number of machine in the cell. Then the stationary availability will be given by the expression (9).

$$A_{cell}(\infty) = \frac{1}{1 + \sum_{i=1}^m \frac{\lambda_{i.Fc^*}}{\mu_i}} \quad (9)$$

3. Problem definition and solution technique

The failure of only one machine in the cellular manufacturing system can disrupt the product flow in the whole system. Indeed, this failure is going to generate the interruption of different machine in the corresponding cell. It implies a reduction of the machine utilization rate, a reduction of the production capacity and a dissatisfaction of customers. In this study we are interested in a solution based on the external routing flexibility. This solution has the tendency to apply a strategy that permits to reduce the severity of the failure by the application of an intercellular transfer policy in case of breakdown of a machine of the cell. For a production cell treating a type of product, the breakdown of a machine doesn't imply the interruption of the production in this cell. Sometimes the continuity of the production will be assured by the transfer of the product flow toward a neighbouring cell admitting an inactive machine capable to treat this product type. By this action, it will be possible to continue the process of manufacturing in presence of the fault. The cell will be formed by machines of the first cell and the standby machine of the second cell. The creation of this intercellular transfer is the origin of the formation of the virtual cells. Then virtual cells are created periodically, for instance at machine breakdown, depending on the presence of the failure and the standby machine. It is necessary to note that the realization of intercellular transfer can bring advantages at the level of performance of the system taking into account the transfer duration, the inactivity delay of the standby machine and the repair duration.

Therefore, for the studied system the strategy consists in applying the intercellular transfer of the cell (a) toward the cell (b) in case of failure of one of machines of the first cell (see Figure 1).

The production cell can be assimilated to a repairable system operating according to a set structure composed of (M) independent modules. The number of modules is equal to the number of machines constituting the studied cell (a). Then the block diagram of cell reliability (a) is given by Figure 2.

We study the system in steady state; that is where the probability of the system being in a given state does not depend on the initial conditions. In the case of an application of a transfer policy, the availability of the cell is determined from different module availability. The availability of module (2) will be determined with the process of Markov chains.

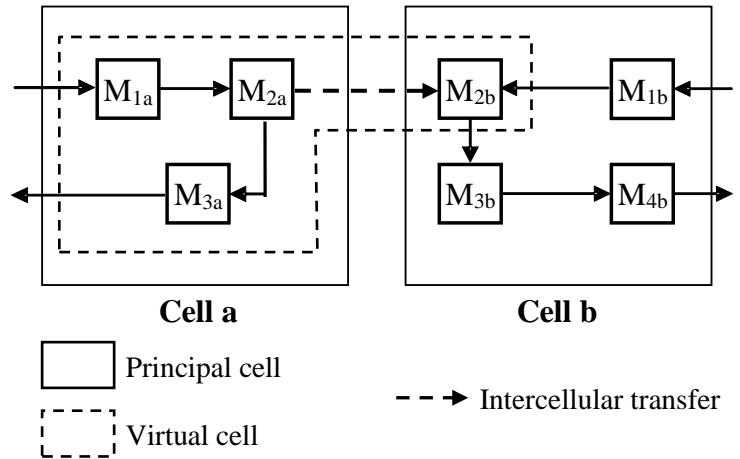

Figure 1. Manufacturing system with intercellular transfer

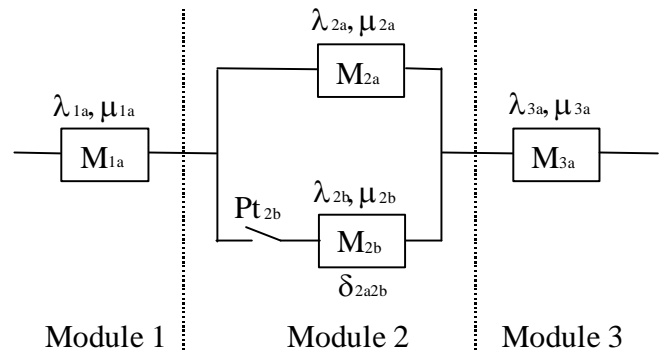

Figure 2. Function block diagram of cell reliability (a)

For this reason, we are considering the module represented by both machines: the main machine and the standby one. The main machine M_1 belonging to the studied cell, exhibits breakdown and repair rates λ_1 and μ_1 respectively. The standby machine M_2 is characterized respectively by breakdown and repair rates λ_2 and μ_2 . In case of a breakdown of the main machine, the probability of transfer toward the replacement machine M_2 is equal to Pt_2 with a transfer rate equal to δ_{12} .

The Markov process describing the evolution of the stochastic behaviour of the module is given by the state diagram depicted in Figure 3.

Given a set of differential equations developed from the diagram, we can determine the module availability represented in the following operational states 1, 2₁, and 2₂. Therefore, the stationary availability is valued by the expression (10).

$$A_{Module}(\infty) = \frac{\delta_{12} \cdot (\mu_1 \cdot \mu_2 \cdot (\mu_1 + \lambda_1 + \mu_2 + \lambda_2) + \lambda_1 \cdot Pt_2 \cdot (\mu_1 \cdot \lambda_2 + \mu_1 \cdot \mu_2 + \lambda_1 \cdot \mu_2 + \mu_2^2))}{\left(\begin{aligned} &\lambda_1 \cdot \lambda_2 \cdot \delta_{12} \cdot Pt_2 \cdot (\mu_1 + \lambda_1) + \delta_{12} \cdot \mu_2 \cdot (\lambda_1 \cdot (\mu_2 + \lambda_1) + \lambda_2 \cdot (\mu_1 + \lambda_1)) \\ &+ \mu_1 \cdot \mu_2 \cdot \lambda_1 \cdot Pt_2 \cdot (\lambda_2 + \mu_2 + \mu_1 + \lambda_1) + \mu_1 \cdot \mu_2 \cdot \delta_{12} \cdot (\mu_1 + 2 \cdot \lambda_1 + \mu_2) \end{aligned} \right)} \quad (10)$$

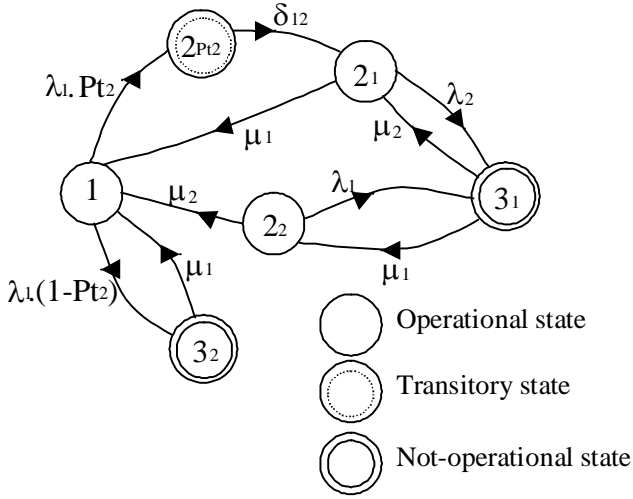

Figure 3. Diagram of module state

Besides, the expression (10) shows that intercellular transfer in case of failure permits to improve the stationary availability of the module, only in the case where the transfer rate is superior to a limit value (δ_{12}^*). This value is given by the expression (11).

$$\delta_{12}^* = \frac{\mu_1^2 \cdot (\mu_1 + \lambda_1 + \mu_2 + \lambda_2)}{\mu_1^2 + 2 \cdot \mu_1 \cdot \lambda_1 + \lambda_1^2 + \mu_1 \cdot \mu_2 + \mu_2 \cdot \lambda_1} \quad (11)$$

With the help of a good team of maintenance arranging some necessary logistical means, the time of preparation of an intercellular transfer can be reduced. In these conditions, times of transfer preparation can be disregarded in front of times between failings and repair machine times. Therefore, the expression of the availability of the module will be given by the expression (12).

$$A_{Module}(\infty) = \frac{(\mu_1 \cdot \mu_2 \cdot (\mu_1 + \lambda_1 + \mu_2 + \lambda_2) + \lambda_1 \cdot Pt_2 \cdot (\mu_1 \cdot \lambda_2 + \mu_1 \cdot \mu_2 + \lambda_1 \cdot \mu_2 + \mu_2^2))}{(\lambda_1 \cdot \lambda_2 \cdot Pt_2 (\mu_1 + \lambda_1) + \mu_2 \cdot (\lambda_1 \cdot (\mu_2 + \lambda_1) + \lambda_2 \cdot (\mu_1 + \lambda_1))) + \mu_1 \cdot \mu_2 \cdot (\mu_1 + 2 \cdot \lambda_1 + \mu_2)} \quad (12)$$

4. Simulation of manufacturing cells

To conduct our simulation, we defined first the problem and stated our objectives. The problem facing cellular manufacturing is the effect of breakdown machines. The objectives of this simulation were to examine the performance of the system with and without the policy of intercellular transfer in the event of breakdowns and to validate the analytical model.

We consider the system shown in the Figure 4. The cell (a) is constituted of three different machines dedicated to the manufacturing of two product types. The cell (b) is formed of four different machines capable to manufacture three product types.

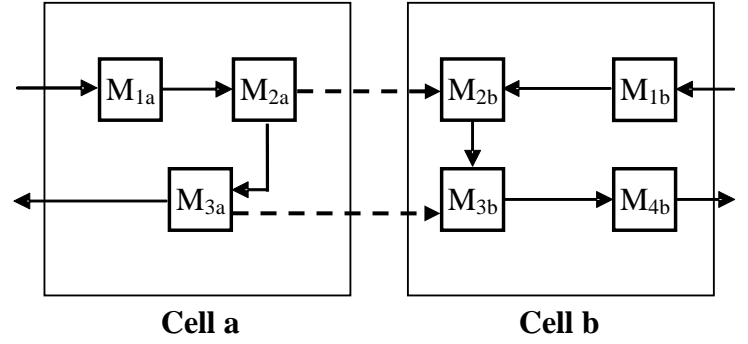

Figure 4. Manufacturing system with intercellular transfer

Table 1 summarizes the routing and the processing time information of each part

Table 1. The routing and processing times of each part

	Product type	Batch size	Machine (Processing times)
Cell a	1	19	M ₁ (19) → M ₂ (12) → M ₃ (13)
	2	30	M ₂ (10) → M ₃ (9)
Cell b	3	16	M ₁ (14) → M ₂ (11) → M ₄ (13)
	4	25	M ₁ (16) → M ₃ (14) → M ₄ (11)
	5	20	M ₂ (17) → M ₃ (13) → M ₄ (7)

The mean time to failure (*MTTF*) and the mean time to repair (*MTTR*) for all machines are shown in Table 2.

Table 2. *MTTF* and *MTTR* of each machine in the system

Machine	M _{1a}	M _{2a}	M _{3a}	M _{b1}	M _{b2}	M _{b3}	M _{b4}
<i>MTTF</i>	6000	3500	3000	5500	4000	3500	6500
<i>MTTR</i>	500	420	350	400	400	360	380

In this paper, the batches arrival is considered cyclic. Indeed, the manufacturing of a new batch is only permitted if the previous batch is finished. In addition, products are generated in a cyclic manner. For a given batch, the time between the arrivals of two products is equal to the time of execution of the first operation.

We perform discrete flow simulation using simulation software called ARENA. We simulate the system during a 12 years horizon; during the first 60000 minutes, statistics are not collected. This warm-up period (the first 60000 minutes) is used to avoid transient effects on the final results.

4.1. Study of the system without intercellular transfer

In this section we simulate our system without the intercellular transfer policy in order to validate our model of cellular system and the developed expressions. The following table summarizes the values of the parameters developed according to the analytical model and that of simulation.

Table 3. Results from the approximate method and simulation

Machines	M _{1a}	M _{2a}	M _{3a}	M _{b1}	M _{b2}	M _{b3}	M _{b4}
$Tu^*_{analytic} (%)$	42.53	62.21	60.91	50.77	41.98	49.63	50.69
$Tu^*_{simulation} (%)$	42.56	62.26	60.96	50.61	41.85	49.47	50.53
Error (%)	< 1 %						
$A^{(\infty)}_{analytic} (%)$	96.46	92.54	92.89	96.31	95.8	94.9	97.04
$A^{(\infty)}_{simulation} (%)$	96.53	92.67	92.84	96.01	95.68	94.79	97.37
Error (%)	< 0.5 %						

The obtained results show that the error between the values given by the analytical formulation and simulation is relatively small. Then the approximation of the cell to a production line working under a continuous and constant load is sufficiently robust to estimate the availability of the autonomous cells.

4.2. Study of the system with intercellular transfer

For the studied system, the strategy consists in applying the intercellular transfer of the cell (a) toward the cell (b) in case of failure of one of machines of the first cell (see Figure 4). We assume that preparation times of intercellular transfer are negligible compared to times between failings and repair machine times.

The values of the availability governed by the two types of policy with and without transfer are calculated according to the analytical model. The obtained results show the improvement made by the application of the intercellular transfer policy in term of cell availability (see Figure 5).

To evaluate the performance of our policy with simulation tool and to support the results of the analytical model, we select the productivity of the cell, presented in the number of produced pieces, and machine utilization rate as performance criteria (see Table 4).

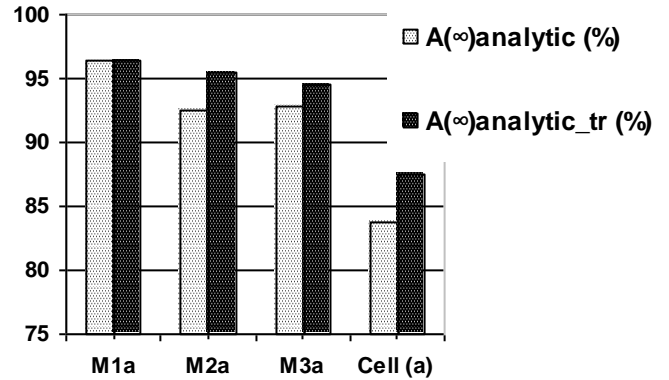

Figure 5. Improvement of the availability by the intercellular transfer policy predicted by the analytical model

Table 4. Performance of the cell (a) with and without intercellular transfer policy from simulation

Machine		Cell (a)		
		M _{1a}	M _{2a}	M _{3a}
Utilization rate (%)	Without transfer	42.56	62.26	60.96
	With transfer	44.12	62.95	62.40
Number of manufactured products	Without transfer	346650		
	With transfer	359337		

The simulation results show that intercellular transfer policy improves the machines utilisation rate and the productivity of the cell. This improvement reflects the augmentation of cell availability.

5. Conclusion

In this paper, an analysis of cellular manufacturing system is presented. The notion of virtual cells and intercellular transfer allowed the development of a solution, which overcomes the effect of failures by continuing the process with the machine of the adjacent cell. Analytical modelling makes possible to determine the expression of the availability of the cell and to explain the improvement obtained by applying the intercellular transfer policy. The simulation results validated our analytical model and proved the effectiveness of the applied policy in the improvement of the system performance.

References

[1] Banerjee, A. & Flynn B. (1987). A Simulation Study of Some Maintenance Policies in a Group Technology Shop. *International Journal of Production Research*. 25, 1595-1609.

- [2] Buzacott, J.A. (1968). Prediction of the efficiency of production systems without internal storage. *International Journal of Production Research*. 6, 173-188.
- [3] Geonwook, J., Herman, R.L. & Hamid, R.P. (1998). A cellular manufacturing system based on new similarity coefficient which considers alternative routes during machine failure. *Computers and Industrial Engineering*. 35, 73-76.
- [4] Lahoti, A. & Kennedy W.J. (1991). Analyzing the Effect of Installing Diagnostic Equipment in a Manufacturing Cell. *Proceeding of the IEEE Annual Reliability and Maintainability Symposium*. 10-14.
- [5] Savsar, M. (2006). Effects of maintenance policies on the productivity of flexible manufacturing cells. *OMEGA the International Journal of Management Science*. 34, 274-282.