

Arrangement of combustion system in experimental variable compression ratio engine

Abstract: Development work on the innovation, experimental design of variable compression ratio combustion engine are continued (comp. PTNSS–2009–SC–062 paper). Their goal is four-cylinder, VCR direct injection engine, where compression ratio alteration will be performed due to shifting and positioning cylinder-cylinder head assembly relatively to the fixed crankshaft position. One of the crucial matter is the selection of elements and parameters in the combustion system in order to provide a diversity and wide range of prospective research. The factors like the range of compression ratio variability, combustion bowl shape, number and distribution of fuel sprays and fuel injection rate are fundamental here. These parameters directly affects the combustion process, which is characterized by the heat release rate, cylinder pressure rate and its maximum value, harmful exhaust emission. The paper presents the selection criteria for design factors of combustion system and the analysis of their effects on combustion process characteristics. For this aim a computer simulation model of the VCR engine has been used.

Key words: combustion systems, compression ratio, direct fuel injection, air-fuel mixture formation, rate of heat release, cylinder pressure.

Konfiguracja systemu spalania w eksperymentalnym silniku o zmiennym stopniu sprężania

Streszczenie: Prace rozwojowe nad konstrukcją innowacyjnej, badawczej jednostki napędowej o zmiennym stopniu sprężania są kontynuowane (por. PTNSS–2009–SC–062). Ich celem jest opracowanie czterocylindrowego silnika tłokowego typu VCR (variable compression ratio) z wtryskiem bezpośrednim, w którym zmiana stopnia sprężania odbywać się będzie poprzez przesuwanie i odpowiednie pozycjonowanie zespołu cylinder-głowica względem ustalonego położenia wału korbowego. Jedną z zasadniczych kwestii jest odpowiedni dobór elementów i parametrów roboczych systemu spalania celem zapewnienia różnorodności i możliwie szerokiego zakresu przyszłych prac badawczych. Istotnymi parametrami są tutaj: zakres zmienności stopnia sprężania, kształt komory spalania, liczba i rozkład strug wtryskiwanego paliwa oraz przebieg wtrysku. Parametry te mają bezpośredni wpływ na proces spalania, którego charakterystycznymi cechami są przebieg wydzielania ciepła, szybkość narastania i maksymalna wartość ciśnienia w cylindrze, emisja szkodliwych składników spalin. Artykuł przedstawia kryteria doboru i analizę wpływu wybranych cech konstrukcyjnych systemu spalania na charakterystykę procesu spalania. W tym celu wykorzystano komputerowy model symulacyjny silnika o zmiennym stopniu sprężania.

Słowa kluczowe: systemy spalania, stopień sprężania, wtrysk bezpośredni paliwa, tworzenie mieszanki palnej, przebieg wydzielania ciepła, ciśnienie w cylindrze.

1. Introduction

Presently, the most important strategy in combustion engine development is simultaneous reduction of total exhaust toxicity and fuel consumption. This task encounters many problems. They stem from complex physical and chemical interactions in working cycle of piston engines, especially during combustion stage. Improving parameters of exhaust emission usually claims resignation from good fuel efficiency, and vice versa, fuel consumption decreasing causes higher toxic emission. This is because the present means of engine operation optimizing, such multi-split injection and injection pressure increasing in diesel engines, are close to the boundaries of their

effectiveness, that have the character of systematic limitations.

Finding the ways for improving combustion engines, a considerable progress has been done, but further measures toward their ecological and energetic performances face mentioned system limits, elimination of which requires major changes in engine designs.

One of the important design parameters for internal combustion engines is the geometric compression ratio ϵ . It is defined by the ratio of the maximum volume of the combustion chamber V_{\max} at the bottom dead center (BDC) piston position and a minimum volume of the combustion chamber V_{\min} at the top dead center (TDC) piston position. Conventional engines have this parameter set as unchangeable, what is not the solution for optimal

benefits that might have been derived from combustion process, especially under altering conditions of load and speed, typically occurred in powering road vehicles. It also reflects in exhaust emission problems.

Due to the direct relationship with the efficiency of the thermal cycle, there is a tend to use the higher degrees of compression ratio in modern combustion engines. Compression ratio in the conventional engine is always a compromise between obtaining high total efficiency and other constraints in operating parameters, such as knock limit, the level of mechanical and/or thermal strains, the maximum rate of pressure rise, charging ratio, exhaust emission, etc. These constraints are relevant only at high loads, and for these conditions are optimized. However, for the traction engines is not a significant area of normal operation. At low and moderate loads, the compression ratio could be much higher, resulting in an increase in overall energy efficiency of the vehicle without negative effects. Hence the idea of engine design with variable compression ratio adjustment is highly up-to-date. In such innovative engine designs, so-called variable compression ratio VCR, the geometric compression ratio parameter is one of the fast-speed operation adjustment regulators.

2. VCR Engine project overview

A few techniques of compression ratio continuous variation have been adapted to the real

engines [5]. Until now, all of them have not gone beyond the stage of studies, research and prototypes. The most known designs and methods are:

- a) articulated monohead (dev. by SAAB),
- b) piston of variable deck height (Daimler-Benz),
- c) eccentrics on crankshaft bearings (FEV),
- d) multilink rod-crank mechanisms (Nissan),
- e) secondary moving piston or valve in cylinder head (Ford),
- f) gear-based crank mechanisms (MCE-5),
- g) precisely shifted cylinder block - cylinder head assembly – used in authors' own project [3].

Despite of many technical difficulties and their feasibility, each of them has specific advantages, but the drawbacks too. They are widely discussed and described in [4] and [5].

Concerning manufacturing costs and machining abilities, the own-construction of VCR engine is based on standard stock engine 4 VD 14,5/12-1 SRW components. Cylinder lengthwise moving was selected as the technique for compression ratio variation. This method was not previously used because of some difficulties in construction of precise and powerful shifting mechanism. But the latest achievements in mechanical linear actuation technology can bypass these limitations. The actuation system is based at the set of no-backlash, synchronously driven roller screws [3], as is shown in Fig. 1.

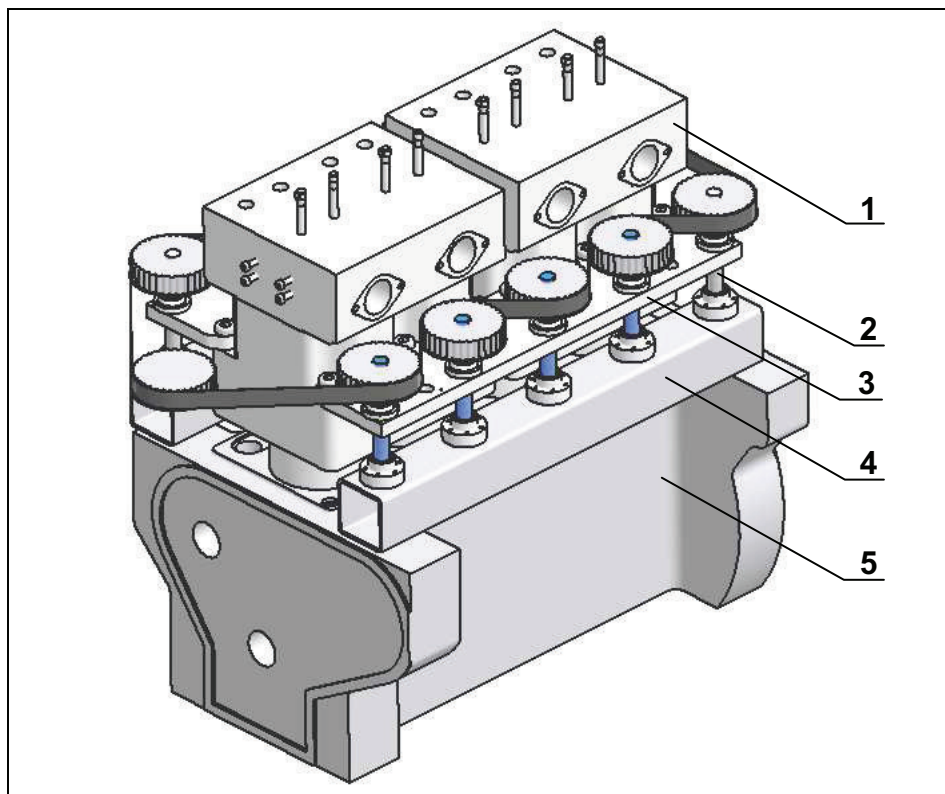

Fig. 1. Self-developed variable compression ratio engine layout [6]: 1 - cylinder block-head assembly, 2 - set of synchronously driven roller screws, 3 - upper support of actuation system, 4 - bottom support of actuation system, 5 - crankshaft block

The engine 4 VD 14,5/12-1 SRW is 4-cylinder, liquid cooled, in-line diesel engine of 6.56 liter of total swept volume. The main engine parameters are shown in table 1.

Table 1. Characteristics of 4 VD 14,5/12-1 SRW engine

Engine type:	4-stroke DI Diesel
Valves design:	OHV
No of cylinders:	4
Cylinders design:	in-line
Firing order:	1-3-4-2
Cylinder bore:	120 mm
Piston stroke:	145 mm
Total swept volume:	6560 cm ³
Original compression ratio:	18:1
Rated power:	92 kW (125 bhp)
Rated speed:	2300 rpm
Max. torque:	430 N·m
Max. torque speed:	1350 rpm
Min. fuel consumption:	218 g/(kW·h)

3. Compression ratio vs. cylinder charge preparation and combustion parameters

Compression ratio is the factor that substantially affects thermodynamic parameters of the cylinder

charge in the entire operation cycle. For engines with direct injection (DI) this effect is especially visible in the processes of air-fuel mixture formation and subsequent combustion. The compression ratio determines the value of a pressure and temperature in the end of compression stroke (Fig. 2 a), which directly affect the process of fuel auto-ignition and combustion (Fig. 2 b) and the geometry and internal structure of the fuel spray (Fig. 3).

Particularly, a significant impact of in-cylinder counterpressure on fuel spray formation and the quality of fuel atomization can be seen (Fig. 3). The important fuel spray parameters are the spray tip penetration s [mm] and the spray tip angle φ [°]. The spray tip penetration decreases at rising compression pressure, while the spray tip angle goes up. The quality of atomization is characterized by two parameters: the homogeneity and the degree of atomization. According to the definition of the degree of atomization, it is defined by droplet size d_k [μm] (e.g. Sauter mean diameter - SMD), while the homogeneity - by the amount of droplets of equal diameter u_i [%]. The increase of back pressure causes a more uniform fuel droplet size distribution in the stream, but it also increases the mean droplet diameter, which is undesirable.

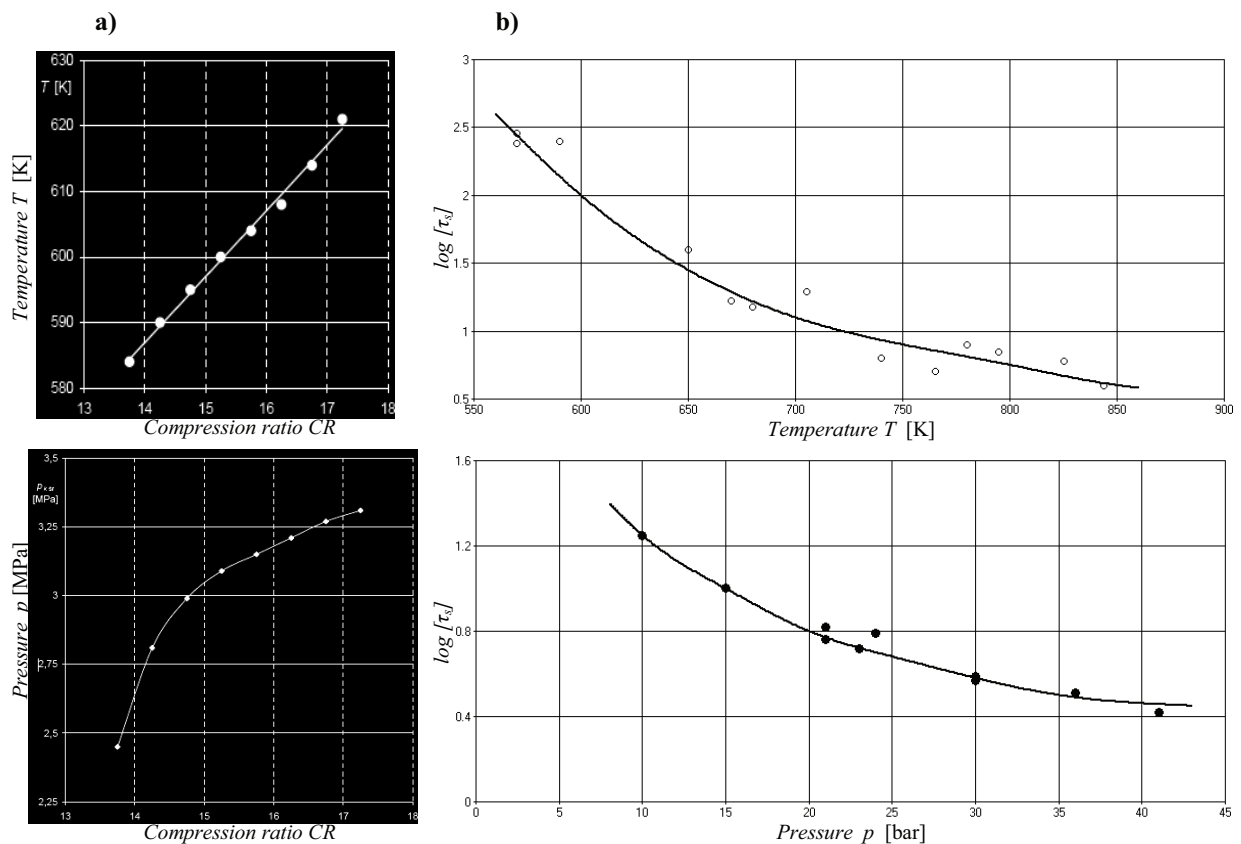

Fig. 2. The effect of compression ratio on temperature T and pressure p at the end of compression stroke (a); the effect of temperature T and pressure p at the end of compression stroke on fuel autoignition delay τ_s (b) [1, 7]

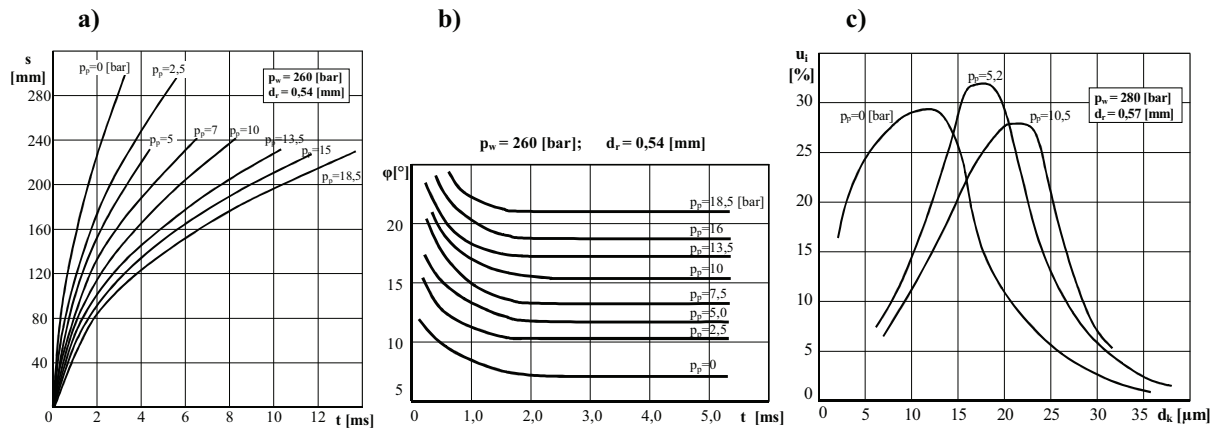

Fig. 3. The effect of in-cylinder counterpressure on fuel spray tip penetration s (a), fuel spray tip angle ϕ (b), and spray droplet size distribution (c) [7]; legend: p_p - in-cylinder back pressure, p_w - fuel injection pressure, d_r - injector hole diameter

4. Research on arrangement of combustion system in VCR engine

In view of discussed circumstances and some determined technical aspects, two combustion systems with different types of bowl shape were taken into consideration at constituting the engine structure. The first one was a sphere shaped bowl with one fuel spray injected tangentially to the bowl wall (well-known M-system), and the second one was a “mexican hat” bowl with two fuel sprays injected across the bowl space (Fig. 4).

For such combustion system arrangements some simulation tests have been performed. Their goal was to check the engine operation at various compression ratios. The Diesel-RK full cycle thermodynamic engine simulation tool has been used for the calculations [2]. Main features of program Diesel-RK are similar to other known

zero-dimensional programs like: WAVE (Ricardo Software), GT-Power (Gamma Technologies) and BOOST (AVL). However, Diesel-RK offers a true multi-zone model for diesel fuel spray mixture formation including fuel spray visualization tool. It allows multiparametric and multidimensional optimization of engine parameters with detail kinetic mechanism of NO formation.

The Diesel-RK internal mathematical model takes into account: engine geometry parameters; the shape of injection profile including split injection; drop sizes; direction of each spray in the combustion chamber; the swirl intensity; the piston bowl shape; chemical reactions with harmful compounds emission; etc. Evolution of wall surface flows generated by each spray reflects the spray and wall impingement angle and the swirl intensity.

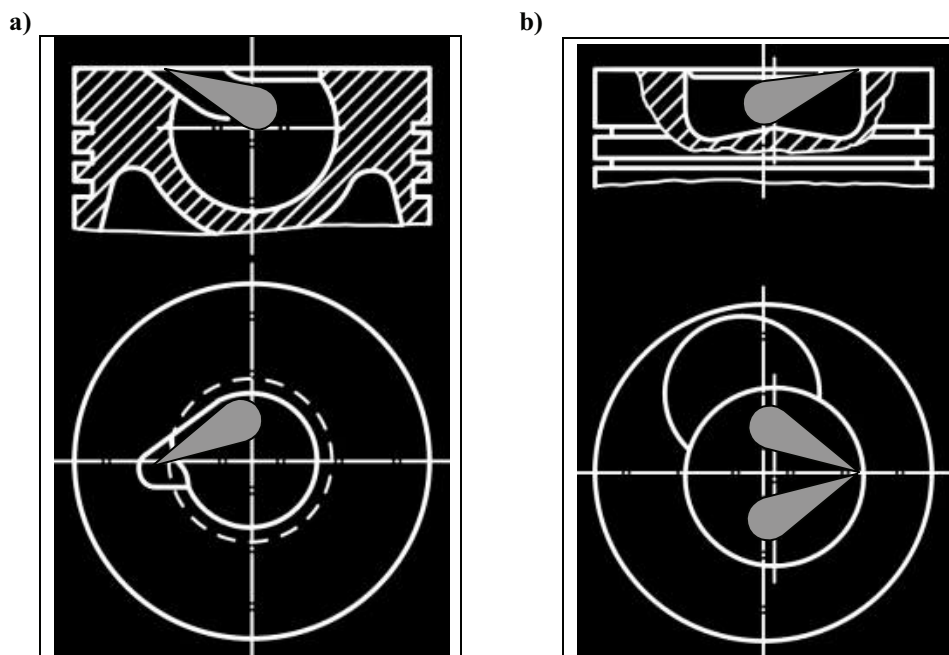

Fig. 4. Two variants of combustion systems taken for analysis of VCR engine operation: (a) – M-system bowl with one fuel spray injected tangentially to the wall, (b) – “mexican hat” bowl with two fuel sprays injected across the bowl space

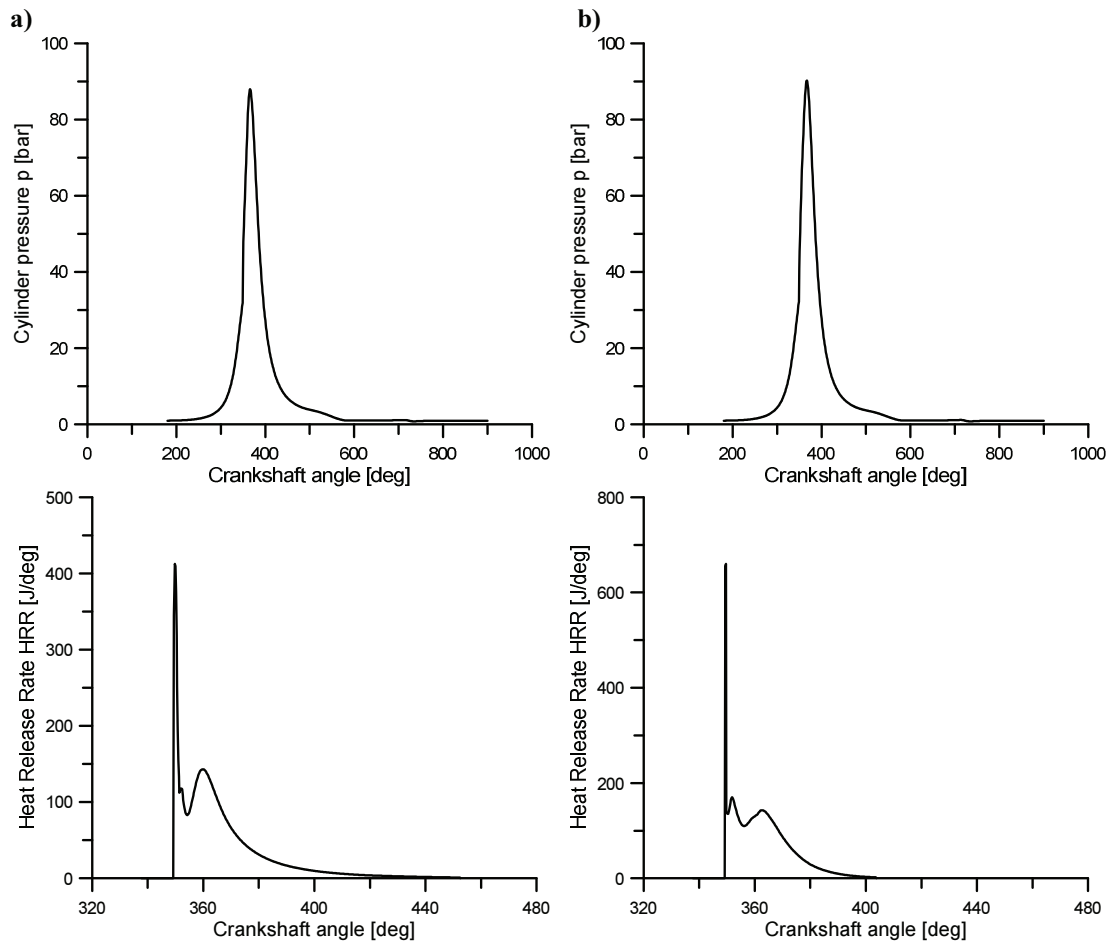

Fig. 5. Comparison of cylinder pressure course and heat release rate for : (a) – M-bowl system, (b) – “mexican hat” bowl system engine speed = 1300 rpm, engine load = 100%

It also makes possible to change the compression ratio by virtual moving the cylinder block-head assembly in the same way as in the real, self-developed engine. This functionality and user-friendly programming environment decided on its selection for the analysis.

In the program all engine data have been implemented including:

- piston stroke and cylinder bore,
- combustion chamber dimensions and geometry,
- direction of fuel spray,
- geometry of charge exchange system,
- actuation characteristics and timing of valves,
- fuel injection system parameters.

Before simulations to be made, the model was tuned to get a conformity with real object. Particularly it concerned the amount of fuel injected per cycle, the start of fuel injection, and maximum fuel injection pressure. These parameters were varied for matching the model output parameters with experimental data derived from engine tests. It can be noticed that very high consistency of both data has been achieved, what goes to show a proper engine working mapping by the program.

The simulation program makes possible choosing such parameters of the two combustion systems to maintain accurate and comparable indicators of the engine working, both in terms of efficiency and ecological features (Fig. 5). From the perspective of the planned research on low-temperature combustion the 'mexican hat' chamber is more advantageous, but in the conventional combustion mode it shows more intensive heat release (Fig. 5), which is a bit negative, especially for environmental reasons (harmful compounds emission).

5. Conclusions

VCR technology is the promising way for combustion engine development. Detailed study proves that it can improve engine parameters by giving an effective regulator for combustion process managing according to the present and further environmental restrictions and fuel economy demands. The paper demonstrates that simulations can also help to design internal structure of VCR engines.

Nomenclature/Skróty i oznaczenia

CA	Crankshaft angle/kąt obrotu wału korbowego	p	Pressure/ciśnienie
CR	Compression ratio/stopień sprężania	s	Spray tip penetration/zasięg czola strugi paliwa
DI	Direct Injection/wtrysk bezpośredni paliwa	SMD	Sauter mean diameter/średnia średnica kropli wg Sautera
d_k	diameter of droplet/średnica kropli	T	Temperature/temperatura
HRR	Heat release rate/szybkość wydzielania ciepła	VCR	Variable Compression Ratio/zmienny stopień sprężania
M	MAN bowl and combustion system/komora i sytem spalania typu MAN	φ	Spray tip angle/kąt czola stugi paliwa
NO	nitric oxide/tlenek azotu		
OHV	Overhead valves/układ rozrządu górnorozworowy		

The research work is supported by budgetary resources for science in 2010-2013 years as a grant No N N509 567639

Praca naukowa finansowana ze środków budżetowych na naukę w latach 2010-2013 jako projekt badawczy Nr N N509 567639

Bibliography/Literatura

- [1] Abramek K.F.: Zmiana stopnia sprężania i jej wpływ na właściwości rozruchowe silników z zapłonem samoczynnym. Zeszyty Naukowe Akademii Morskiej w Szczecinie, nr 10/2006.
- [2] Kuleshov A.S., Multi-Zone DI Diesel Spray Combustion Model and its application for Matching the Injector Design with Piston Bowl Shape, SAE Paper, No 2007-01-1908, SAE, Warrendale, PA, 2007.
- [3] Lejda K., Woś P., A Preliminary Project of Multi Cylinder, Variable Compression Ratio (VCR) Engine for Research Purposes, Combustion Engines, vol. SC2, Paper No PTNSS-2009-062.
- [4] MCE-5 Development Tech Newsletters: <http://www.mce-5.com>.
- [5] Shaik A., Shenbaga Vinayaga Moorthi N., Rudramoorthy R.: Variable compression ratio engine: a future power plant for automobiles – an overview. Proceedings of the Institution of Mechanical Engineers (IMEchE); Part D: Journal of Automobile Engineering, Vol. 221, No D9, 2007.
- [6] Woś P., Kuszewski H., Ustrzycki A.: Exhaust emission features of variable compression ratio (VCR) diesel engine. Journal of KONES Powertrain and Transport, Vol. 17, No. 3, 2010.
- [7] Zabłocki M.: Wtrysk i spalanie paliwa w silnikach wysokoprężnych. WKiŁ, Warszawa 1976.

Prof. Kazimierz Lejda, DSc., MEng. – Professor in the Faculty of Mechanical Engineering and Aeronautics at Rzeszów University of Technology.

Prof. dr hab. inż. Kazimierz Lejda – profesor na Wydziale Budowy Maszyn i Lotnictwa Politechniki Rzeszowskiej.



Paweł Woś, PhD., MEng. – Assistant Professor in the Faculty of Mechanical Engineering and Aeronautics at Rzeszów University of Technology.

Dr inż. Paweł Woś – adiunkt na Wydziale Budowy Maszyn i Lotnictwa Politechniki Rzeszowskiej.

