

A Novel Approach for Automatic Control of Piezoelectric Elements Used for Lorentz Force Detuning Compensation

Konrad Przygoda, Tomasz Pozniak, Andrzej Napieralski
 Department of Microelectronics and Computer Science
 Technical University of Lodz
 Lodz, Poland
 {kprzygod, pozniak, napier}@dmcs.pl

Mariusz Grecki
 Group of Maschine Strahlkontrollen
 Deutsches Elektronen-Synchrotron
 Hamburg, Germany
 mariusz.grecki@desy.de

Abstract—Linear accelerators such as Free Electron Lasers (FELs) use superconducting (SC) resonant cavities to accelerate electron beam to high energies. TESLA type resonators are extremely sensitive to detuning induced by mechanical deformations – Lorentz force detuning (LFD), mainly due to the extremely high quality factor (Q) of the 1.3 GHz resonance mode, in the range of 10^6 . The resulting modulation of a resonance frequency of the cavity makes power consumption and stability performances of the Low-Latency Radio Frequency (LLRF) control more critical. In order to minimize the RF control efforts and desired stabilities, the fast piezoelectric actuators with digital control systems are commonly used. The paper presents a novel approach for automatic control of piezoelectric actuators used for compensation of Lorentz force detuning, the practical application and carried out tests in accelerating module ACC6 in Free-Electron Laser in Hamburg (FLASH).

Index Terms—Lorentz force detuning compensation, piezoelectric actuators, superconducting resonance cavity

I. INTRODUCTION

Linear accelerators constitute one of the most important components of modern light sources such as FELs. The length of such facilities may reach more than several hundred meters. Such accelerators consists of superconducting resonance cavities which are used to accelerate the electron beam to high energies. The SC cavities are powered by pulsing Radio Frequency (RF) waves that interact with the walls made of niobium due to the Lorentz forces [1], [2]. The detuned cavity requires additional RF power for cavity field control and stability. To minimize the RF control efforts and power, the Lorentz force detuning can be compensated using scheme based on the fast mechanical tuning system with piezoelectric actuators. Presently under studies at many labs are different tuning systems and control techniques for LFD compensation [5]-[12]. Among the few electro-mechanical static tuning solutions, based on step motors, that have been realized in the frame of TESLA technology collaboration, the currently developed cavity tuners, referred as Saclay-I and II [3] and coaxial Blade Tuner [4], seems to be the most attractive solutions for compensation purpose. The typical control scheme, proposed at many labs, is based on response of the detuning curve to the piezo driving voltage applied prior to the RF field pulse [3]. The alternative solution described in [9], is

based on harmonic analysis of the Lorentz force detuning but it needs further development as well as more simplification for practical applications. Moreover, the cavity model studies based on power forward signal, field probe signal, and the phase difference between them, allows achieving the efficient control of piezo elements [12].

Over the last several years, Deutsche Elektronen-Synchrotron (DESY) has become actively involved in the development and testing of digital control systems for SC cavity fast tuners. The prototype LLRF control boards such a Simcon 3.1 [13] and Simcon DSP have been developed and successfully demonstrated for cavity filed control as well as Lorentz force detuning compensation [14]. The paper presents the novel approach for automatic control of piezoelectric actuators used for Lorentz force detuning compensation. The method is based on dependence of compensated LFD over the flattop region versus the applied piezo pulse amplitude. The Lorentz force detuning studies were carried out with different setups of accelerating field gradient. The control system was implemented using FPGA and its practical application was ported to Simcon DSP. The control boards were connected with optical links to be capable of compensating the 8 cavities simultaneously. The system was temporary installed and tested in accelerating module ACC 6 in FLASH facility.

II. LORENTZ FORCE DETUNING COMPENSATION FOR PULSED OPERATION

When cavity is operated in pulsed mode, the mechanical deformations excite several mechanical modes leading to a dynamic detuning during the RF field pulse. The fact makes power consumption and stability performances of the LLRF control more crucial. Direct experiences widely proved that successful results of Lorentz force detuning compensation can be obtained using single piezoelectric actuator acting, locally on the cavity edge and mainly on its length [4].

The chosen strategy has been to roughly duplicate the kind of excitation provided by the RF field pulse itself. Since the capacitive behavior of the piezo elements requires avoiding sharp transitions in the driving signal that would lead to undesirable current spikes, a single period of sinusoidal pulse with total time width of 4 ms has been proposed. Very short

pulses as well as significantly steeper rises in the driving pulse would not be far more effective at all for LFD compensation purpose, since the cavity mechanical dynamic would cut off higher harmonics included in the signal. The Lorentz force detuning is decoupled into static and dynamic detuning. The dynamic detuning is computed over the flattop region of the RF field pulse that means between points of ω_1 and ω_2 (see Fig. 5). The static detuning is estimated as an offset of detuning curve with reference to zero Hz on the vertical axis. The cavity static and dynamic detuning is graphically shown in Fig. 5.

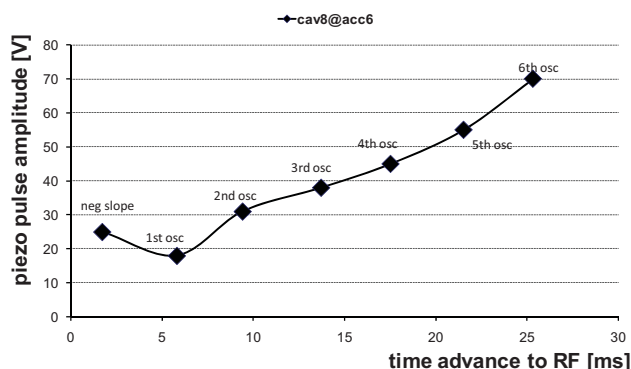

Figure 1. The linear function fitting of piezo pulse amplitude versus time advance to RF field pulse in cavity #8 in ACC6.

The compensation of Lorentz force detuning studies were carried out using simple feedforward control scheme. The feedforward tables were manually tuned and successively applied to piezo actuator using readouts of Lorentz force detuning compensation. The compensation pulse shape was synchronized to RF field pulse using external trigger signal. The measurements proved that besides amplitude, the time advance or delay between piezo pulse start and RF field pulse start also plays an important role for compensation of LFD [15]. Experimental investigations of this aspect of the control of dynamic LFD have been performed using desired amplitude for chosen time node of so called n-free oscillation induced by the piezo pulse compensation. Figure 1 shows successful results of Lorentz force detuning compensation using desired piezo pulse amplitude applied for different time delays prior to the RF field pulse.

As one can noticed, the Lorentz force detuning can be compensated using two schemes. The first method is based on short time delays (less than 2 ms) of applied piezo pulse compensation. The compensation signal directly reacts on the RF pulse excitation using first negative slope of the compensation pulse. The second method is based on long time delays (more than 5 ms) of applied piezo pulse compensation. The compensation signal acts on the RF pulse excitation using free oscillations induced by piezo pulse. It is clearly reasonable that for the significantly long as well as short time delays (the backward forecast using 4th order polynomial) the amplitude of piezo pulse can reach the voltage levels up to 70 V. As a result, the further compensation studies were performed using first negative slope or first three oscillations induced by piezo compensation in order to avoid voltage amplitudes close to power supply limit of piezo driver units which is in range of ± 80 V.

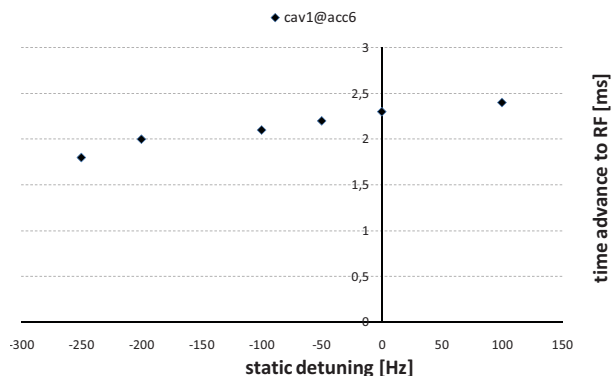

Figure 2. The static detuning compensation using chosen n-free oscillation induced by piezo pulse compensation. The dynamic detuning was compensated with desired piezo pulse amplitude.

Moreover, it was noticed that the static detuning can be efficiently compensated using small time shifts around chosen n-free oscillation induced by desired value of piezo pulse amplitude (see Fig. 1). The experimental results, shown in Fig. 2, considers time advance to RF pulse of 2.3 ms. It allows compensating the static detuning close to 0 Hz. Small time shifts of compensation pulse shows that the static detuning can be easily controlled in range of -250 Hz to +150 Hz. The most important benefits emerge in this configuration are:

- static and dynamic detuning controls are decoupled to two different parameters: the piezo pulse delay and amplitude respectively,
- small amount of static detuning variation can be efficiently compensated without moving the step motors.

Finally, the amount of absolute compensated detuning over the flat top region in each cavity in ACC6 has been investigated. The measurements were linearly interpolated as a function of the amplitude of each applied piezo pulse, while using the same pulse shape. For the compensation purpose the value of 2 ms of time advance to RF pulse was initially used. The experimental results obtained for cavity 8 in ACC6 are depicted in Fig. 3. The measurements were carried out for different accelerating field gradients, starting from 7 MV/m up to 11 MV/m of set point that means probe signal gradients of 15 MV/m and 25 MV/m respectively.

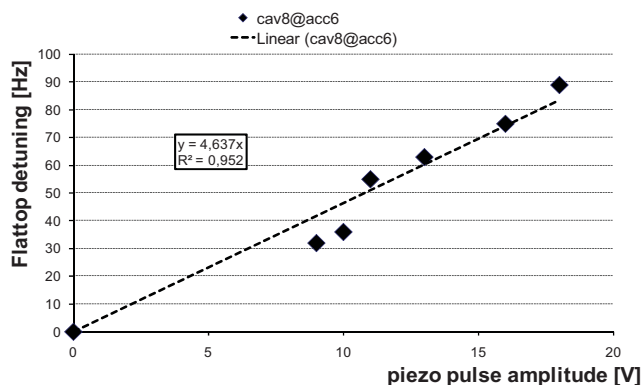

Figure 3. The linear function fitting of compensating Lorentz force detuning over the flattop region versus piezo pulse amplitude in cavity #8 in ACC6.

The obtained linear interpolation coefficients have been summarized in Tab. 1. The linear dependence of compensated detuning over the flat top region found good agreement to a linear function of the applied piezo pulse amplitude.

TABLE I. COLLECTION OF RESULTING FIT COEFFICIENTS

Cavity No.	Resulting fit coefficients
1	2,7
2	3,4
3	3,6
4	4,8
6	2,6
7	3,7
8	4,6
average	3,63 Hz/V

III. THE APPLICATION FOR AUTOMATIC CONTROL OF PIEZO ACTUATORS

The practical application for automatic control of piezoelectric elements was designed as a proof of performed measurements. The application for automatic control of piezo actuators consists of digital control system with ADC inputs and DAC outputs, 8-channel power amplifier – piezo driver and digital downconverter for sensing the RF probe signals (see Fig. 4). The digital control system is based on Simcon DSP prototype boards. The single board is capable of sensing and driving 8 input/output signals. The configuration of three boards connected with optical links allows sensing 24 RF signals. The forward, reflected power and probe field signals are used to estimate cavity detuning for 8 cavities simultaneously. The RF signals from cavity are downconverted and sensed with desired sampling frequency using ADC converters. The DAC converters are used to drive the power amplifier with low voltage signals in range of ± 1 V. The 8-channel piezo driver unit is used to amplify the compensation signals to proper voltage levels of order of ± 80 V [14].

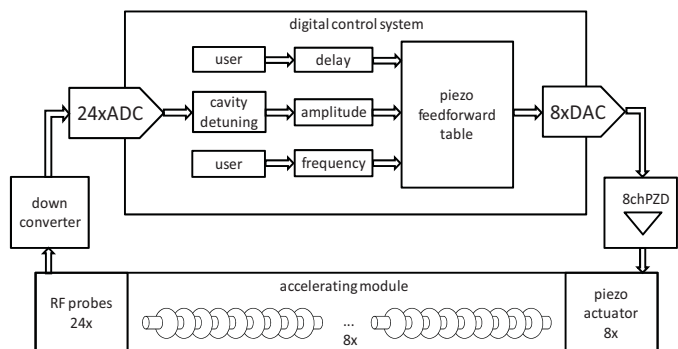

Figure 4. The block diagram of application for automatic control of piezo actuators.

The control algorithm is based on cavity detuning measured over the flat top region (dynamic detuning) of the RF field pulse. The piezo pulse amplitude computation is

based on simple proportional gain controller scheme. The difference between start (ω_1) and end (ω_2) of flattop detuning is multiplied by inverted value of linear function slope. The piezo amplitude is updated in successive way in a case of fact that cavity static detuning can be different for various gradients (positive – between +300 and 0 Hz, centered – crossed by 0 Hz or negative – between -300 and 0 Hz). When ω_1 and ω_2 values of the detuning over the flattop are positive and the ($\omega_1 > \omega_2$) dependence is fulfilled, the new calculated amplitude is added to the one computed in previous algorithm step. When ω_1 and ω_2 values are positive and the ($\omega_1 < \omega_2$) dependence is fulfilled the new calculated amplitude is subtracted from the one computed in previous algorithm step. The all dependences as well as crucial cases are shown in Fig. 5.

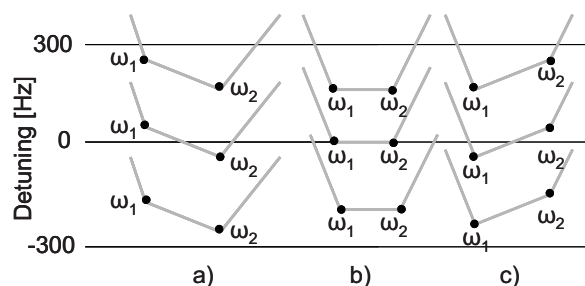

Figure 5. The possible states of the cavity detuning curves (a – without compensation, b – with compensation, c – overcompensation).

The fully scalable and serial pipelined architecture was designed and implemented to meet the multi-cavity configuration. The computations paths were optimized to achieve time delays shorter than 10 ns. The input and output blocks were added to meet different communication interfaces [16]. The automatic method for piezo pulse amplitude was optimized due to the FPGA resource usage. For both cases (addition or subtraction) a single adder was used. The other control logic uses a small amount of registers and flip-flops i.e. to detect the flattop detuning (ω_1 and ω_2 values).

IV. EXPERIMENTAL RESULTS

The measurement setup was temporary installed in ACC6 of FLASH facility. The Simcon DSP boards were installed in VME crate while the 8-channel piezo driver with integrated power supply unit was installed in Eurocrate. The compensation system was synchronized with RF pulse using trigger signal of repetition rate of 5 Hz. The ADC channels of each Simcon DSP board (master and slaves) were connected to digital downconverters for reading the RF signals. The sampling frequency was set to 1 MHz. The master board - controller was connected to 8-channel piezo driver unit. The power amplifiers were connected to piezoelectric actuators. The Lorentz force detuning computation core was first calibrated using Mexfile communication library – coupler directivity calibration of forward and reflected power. The piezo compensation tables were initially setup for each cavity with sinusoidal excitation with full range of 18 bits 2 complement values. The time advance to RF pulse and the frequency of each piezo compensation pulse were set between 2÷5 ms and 250 Hz respectively. Finally, the proportional gain controller coefficients for each cavity were setup. The

compensation system was turned on and the measurements of automatically updated piezo pulse amplitude for each cavity were carried out using monitoring outputs of piezo driver unit and digital scope. Moreover, the compensated flattop detuning was measured for each setup of accelerating field gradient. The example results for cavity #8 are presented in Fig. 6. The obtained results found good agreement to the second order polynomial of piezo pulse amplitude versus the set point gradient [17].

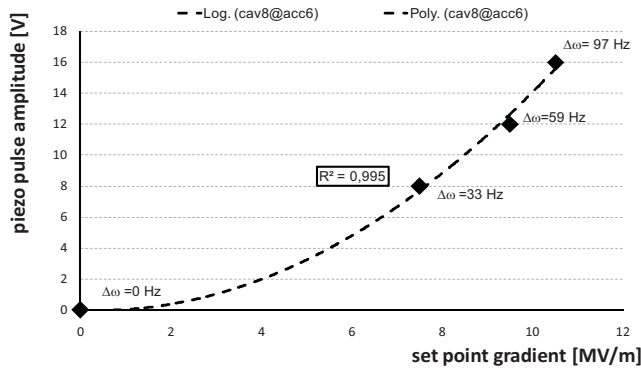

Figure 6. The second order polynomial fitting of piezo compensation pulse amplitude versus set point gradient for cavity 8 in ACC6. The compensated Lorentz force detuning over the flattop region is collected close to each piezo pulse amplitude measurement.

V. CONCLUSIONS

The automatic method for control the piezo pulse amplitude was developed after some experimental measurements of detuning dependence versus applied piezo pulse amplitude. The control algorithm was implemented in FPGA device and successfully demonstrated using practical application temporary installed in ACC6 in FLASH facility. The digital controller was optimized due to the FPGA resource usage as well as time delay data paths less than 10 ns. Future efforts in this development are to add the time advance to RF pulse dependence to closed-loop operation as it is the second most important compensation pulse parameter. Moreover the possibilities of static detuning compensation without using step motor tuners will be considered.

ACKNOWLEDGMENT

The research leading to these results has received funding from the European Commission under the EuCARD FP7 Research Infrastructures grant agreement no. 227579 and Polish National Science Council Grant 642/N-TESLA-XFEL/09/2010/0. The authors are scholarship holders of project entitled "Innovative education ..." supported by European Social Fund.

REFERENCES

- [1] M. Liepe, "Superconducting Multicell Cavities For Linear Colliders," Ph.D thesis, University of Hamburg, 2001.
- [2] L. Lije, S. Simrock, D. Kostin, M. Fouaidy, "Characteristics Of a Fast Piezo-Tuning Mechanism For Superconducting Cavities," Proceedings of EPAC 2002.
- [3] S. N. Simrock, "Lorentz Force Compensation Of Pulsed SRF Cavities," Proceedings of LINAC 2002.
- [4] R. Paparella, "Fast Frequency Tuner For High Gradient SC Cavities For ILC And XFEL," Ph.D. thesis, Universita' Degli Studi Di Milano, 2007.
- [5] E. Kako, H. Hayano, S. Nogushi, N. Ohuchi, M. Sato, T. Shishido, K. Watanabe, Y. Yamamoto, "Cryomodule Tests Of The STF Baseline 9-cell Cavities At KEK", Proceeding of EPAC 2008.
- [6] G. Devans, P. Bosland, M. Desmons, E. Jacques, M. Luong, B. Visentin, "Compensation Of Lorentz Force Detuning Of a TTF 9-cell Cavity With A New Integrated Piezo Tuner", Proceeding of EPAC 2006.
- [7] W. Brautigam, O. Felden, M. Glende, R. Maier, A. Schnase, G. Schung, H. Singer, R. Stassen, "Superconductive Test Cavity For The ESS", Proceedings of PAC 2001.
- [8] T. Saeki and others, T. Kenekiyo and others, "The First Measurement Of Low-loss 9-cell Cavity In A Cryomodule At STF", Proceedings of EPAC 2008.
- [9] M. Doleans, Sang-ho Kim, "Insights In The Physics Of The Dynamic Detuning In SRF Cavities And Its Active Compensation", Proceedings of PAC 2003.
- [10] Y. Pischalnikov and others, "A Technique For Monitoring Fast Tuner Piezoactuator Preload Forces For Superconducting RF Cavities", Proceedings of PAC 2007.
- [11] G. K. Davis, J. R. Delayen, "Piezoelectric Tuner Compensation Of Lorentz Force Detuning In Superconducting Cavities," Proceedings of PAC 2003.
- [12] R. Cargano and others, "First Fermilab Results Of SRF Cavity Lorentz Force Detuning Compensation Using A Piezo Tuner," 13th International Workshop on RF Superconductivity Peking University, Beijing, China 2007.
- [13] W. Giergusiewicz, W. Jalmuzna, K. Pozniak, N. Ignashin, M. Grecki, D. Makowski, T. Jezyński, K. Perkuszewski, K. Czuba, S. Simrock, and R. Romaniuk, "Low latency control board for LLRF system – Simcon 3.1, Photonics Applications in Industry and Research IV, August 2005.
- [14] M. Grecki, A. Andryszczak, T. Poźniak, K. Przygoda, S. Sękalski, „Compensation of Lorentz Force Detuning For SC Linacs (With Piezo Tuners),” Proceedings of EPAC 2008, pp. 862-864.
- [15] K. Przygoda, R. Paparella, "A Novel Approach for Hardware Implementation of a Detuning Compensation Control System For SC Cavities," 14th Int. Conf. MIXDES 2007.
- [16] K. Przygoda, W. Jalmuzna, A. Andryszczak, T. Poźniak, A. Napieralski, "FPGA Implementation of Multichannel Detuning Computation for SC Linacs," Proceedings of EPAC 2008.
- [17] P. Sękalski, "Smart Materials as Sensors and Actuators For Lorentz Force Tuning System," Ph.D. thesis, Technical University of Lodz, 2006.