

# SPATIAL SAS SIGNAL FILTERING BY MEANS OF POLAR FORMAT PROCESSING

MARCIN SZCZEGIELNIAK

University of Technology and Agriculture in Bydgoszcz  
Kaliskiego 7, 85-792 Bydgoszcz, Poland  
marcinszczegielniak@poczta.onet.pl

*Synthetic Aperture Sonar (SAS) is the high-resolution acoustic imaging technique which allows to improve the cross-range resolution. The main possibilities of SAS data gathering are the stripmap and spotlight modes. The stripmap system is only considered and analyzed in this paper. However, the results can be easily copied to the last one. In this specific mode, the sonar beam always points in the same direction (e.g. perpendicular to the direction of the travel) during imaging. The fundamental problem with the extraction of the echoes from the finite seafloor area appears in such a system. In order to deal with this inconvenience, we can take advantage of the well-known polar formatting, what is done in this paper. After that, the Omega-k algorithm is used to show some results of the numerical stripmap SAS system simulation. The outcomes confirm the possibility of the usage of the polar format processing to filter out the SAS signal from the undesirable contributions.*

## INTRODUCTION

The polar format processing is not particularly new and precise as a reconstruction method, but in this case it may be found a virtue. This algorithm has some serious drawbacks like smearing and geometric distortions in the resultant image. But we can use an image obtained by means of this algorithm to filter the SAS signal. It's obvious that the low computational cost or the simplicity becomes its benefit, which allows us to calculate an auxiliary image relatively fast. Then, this image is used for the purpose of spatial filtering.

The accuracy of the polar formatting depends on a few things which are discussed further. It's important that meeting this stuff authorizes us to use the polar format processing as a profitable tool for the extraction of the appropriate SAS signal.

At the beginning we should start with the geometrical model of SAS (Figure 1) and make a few assumptions occurring in this paper. First, for the notation simplification it's possible to define the new variable

$$r = \sqrt{y^2 + h^2} \quad (1)$$

where  $h$  is the altitude of the platform and  $y$  denotes the spatial coordinate according to Figure 1. Thanks to this abbreviation the imaging scene can be represented by the two-dimensional spatial domain  $(x, r)$ .

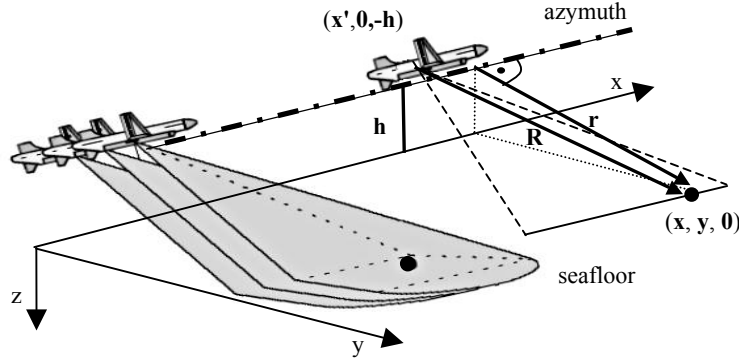

Fig.1 Synthetic aperture imaging geometry

The synthetic aperture domain will be represented by the variable  $\mathbf{x}'$ . Then the received signal by the synthetic aperture sonar is

$$e(\mathbf{x}', t) = \sum_k \sigma_k \cdot p \left( t - \frac{2\sqrt{(x_k - \mathbf{x}')^2 + r_k^2}}{c} \right) \exp \left( j\omega_c \cdot \left[ t - \frac{2\sqrt{(x_k - \mathbf{x}')^2 + r_k^2}}{c} \right] \right) \quad (2)$$

where  $p(t)$  is transmitted pulse with the carrier  $\omega_c$ ,  $c$  is the sound speed in water and  $\sigma_n$  represents unknown reflectivity. After the fast-time baseband conversion and the Fourier transform with respect to fast time we have

$$e(\mathbf{x}', \omega) = P(\omega) \sum_k \sigma_k \cdot \exp \left( -j2k\sqrt{(x_k - \mathbf{x}')^2 + r_k^2} \right) \quad (3)$$

where  $k = (\omega + \omega_c)/c$  is the wavenumber. The equation 3 is the start point for further analysis in this paper.

It's assumed that the sonar is stationary between transmitting and receiving a signal, so-called stop and hop model. Generally, this is not a good assumption for SAS because of the slow propagation speed of the sound. However, it may be valid for systems operating at short target ranges, e.g. for Kiwi-SAS system [1]. The distance to the center of the illuminated area used in the simulation is relatively small (30m) and comparable to the above-mentioned system.

The motion compensation problem is not considered in this article at all. Therefore, it's assumed that the platform carrying sonar moves along an ideal straight track with the constant speed  $v$  and sends successive sound pulses perpendicular to the direction of the travel with the constant **P**ulse **R**epetition **F**requency (PRF). The received echo signals are recorded graphically as consecutive lines, resulting in a two-dimensional reflectivity map of the acoustic backscatter strength.

## 1. THE BASICS OF POLAR FORMAT PROCESING

Transforming the SAS signal given by the equation 3 in order to move the origin to the center of the target area  $(X_c, R_c)$ , we obtain

$$e(\mathbf{x}', \omega) = P(\omega) \sum_k \sigma_k \cdot \exp \left( -j2k\sqrt{(X_c + x_k^T - \mathbf{x}')^2 + (R_c + r_k^T)^2} \right) \quad (4)$$

With the use of the auxiliary function in the form

$$e_a(\mathbf{x}', \omega) = P(\omega) \exp\left(-j2k\sqrt{(X_c - \mathbf{x}')^2 + (R_c)^2}\right) \quad (5)$$

(which represents the echo from the center of the target area, point  $(x_k^T, r_k^T) = (0,0)$ ), the simple multiplication is done in the following way

$$e_p(\mathbf{x}', \omega) = e(\mathbf{x}', \omega) \cdot e_a(\mathbf{x}', \omega)^* = |P(\omega)|^2 \sum_k \sigma_k \cdot \exp\left(-j2k\sqrt{(X_c + x_k^T - \mathbf{x}')^2 + (R_c + r_k^T)^2}\right) \cdot \exp\left(j2k\sqrt{(X_c - \mathbf{x}')^2 + (R_c)^2}\right) \quad (6)$$

It's possible to approximate the phase function by

$$\exp\left(-j2k\sqrt{(X_c + x_k^T - \mathbf{x}')^2 + (R_c + r_k^T)^2}\right) \approx \exp\left(-j2k\sqrt{(X_c - \mathbf{x}')^2 + (R_c)^2} - j2k(x_k^T \cdot \cos\phi + r_k^T \cdot \sin\phi)\right) \quad (7)$$

$$\text{where the angle } \phi = f(\mathbf{x}') = \arctan\left(\frac{X_c - \mathbf{x}'}{R_c}\right)$$

The meaning of this approximation is explained in Figure 2. As we can see the approximation is equivalent to neglecting the wavefront curvature. Then, the result is

$$e_p(\mathbf{x}', \omega) = e(\mathbf{x}', \omega) \cdot e_a(\mathbf{x}', \omega)^* = |P(\omega)|^2 \sum_k \sigma_k \cdot \exp(-2jk \cdot x_k^T \cdot \cos\phi - 2jk \cdot r_k^T \cdot \sin\phi), \quad (8)$$

where the right side takes after the target function in the spatial frequency domain defined by

$$e_p(\mathbf{x}', \omega) = e(\mathbf{x}', \omega) \cdot e_a(\mathbf{x}', \omega)^* = |P(\omega)|^2 \sum_k \sigma_k \cdot \exp(-jk_x \cdot x_k^T - jk_r \cdot r_k^T) \quad (9)$$

It follows that the target function  $\sigma(x,r)$  is achieved by the two-dimensional Fourier transform. However, it's necessary to interpolate the data on a rectilinear grid because of the mapping

$$\begin{aligned} k_x(x', \omega) &= 2k \cos\phi \\ k_r(x', \omega) &= 2k \sin\phi \end{aligned} \quad (10)$$

Moreover, the angle  $\phi$  is not a linear function of the variable  $\mathbf{x}'$  what makes the solution more complicated. We can get over this stuff and reduce this mapping to the form

$$\begin{aligned} k_x(x', \omega) &= 2k \cdot \cos\alpha \\ k_r(x', \omega) &= 2k_c \sin\alpha - 2k_c \frac{\cos^2\alpha}{R_c} \quad \text{where } \alpha = \arctan\left(\frac{R_c}{X_c}\right) \end{aligned} \quad (11)$$

by means of the narrow-bandwidth and narrow-beamwidth approximation for the near-broadside case [2]. The biggest advantage of this mapping is that we don't need an interpolation anymore to place the data on evenly spaced grid. This operation is reduced to the casual scale change.

## 2. SPATIAL FILTERING WITH THE USE OF POLAR FORMATTING

Although, the polar format processing used to be applied as the reconstruction method, it is preferable to filter out the unwanted contributions of the targets beyond the illuminated area [2]. The target function  $\sigma(x,r)$  which describes the examined area is just 2D Fourier transform of the equation 9 from  $(\mathbf{x}', \omega)$  into  $(k_x, t)$  (where the transform from  $\omega$  into  $t$  is the inverse one) what results from the above-mentioned analysis and directly from the equation 11. Spatial filtering in the stripmap SAS system is indispensable because of the manner of the data collecting.

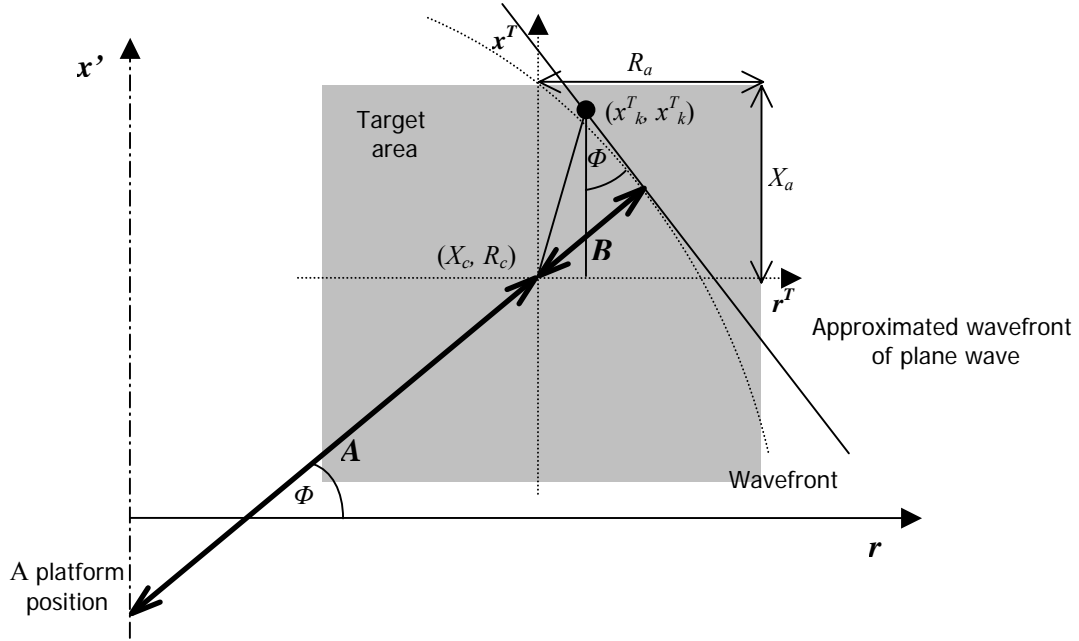

$$\sqrt{(X_c + x_k - \mathbf{x}')^2 + (R_c + r_k)^2} \approx A + B = \sqrt{(X_c - \mathbf{x}')^2 + (R_c)^2} + x_k^T \cdot \cos \phi + r_k^T \cdot \sin \phi$$

Fig.2 Plane wave approximation

Assuming only the main lobe of the radiation pattern in both directions, for the limited area described by

$$\text{Target Area (TA): } x \in [X_c - X_a, X_c + X_a] \wedge r \in [R_c - R_a, R_c + R_a], \quad (12)$$

the SAS echo signal contains the contributions from the targets which are in

$$x \in [X_c - X_a - 2W, X_c + X_a + 2W] \wedge r \in [R_c - R_a, R_c + R_a], \quad (13)$$

where  $W$  is the sonar half-beamwidth in the azimuth direction (along  $x$  axis) and depends on the system parameters and range  $r$ . Therefore, we need a kind of the spatial filter which allows to keep the appropriate contributions and construct the high-resolution image of the illuminated area. For the targets defined by the polar spatial coordinates  $[\Psi_k, R_k]$  when the sonar is at  $\mathbf{x}'=0$ , the contributions appear at [2]

$$t_k \approx \frac{2R_k}{c} \quad \wedge \quad k_{x'k} \approx 2k_c \sin(\Psi_k - \alpha) \quad (14)$$

in the polar format processed SAS image in the time domain  $t$  and the spatial frequency  $k_{x'}$ . In the rectilinear coordinates we have

$$r_k = \frac{c \cdot t_k}{2} \cos(\psi_k + \alpha), \quad x_k = \frac{c \cdot t_k}{2} \sin(\psi_k + \alpha), \quad \text{where } \psi_k = \arcsin\left(\frac{k_{x'k}}{2k_c}\right) \quad (15)$$

Finally, the spatial filter (SF) for the polar format processed SAS image in the  $(k_{x'}, t)$  domain takes the form

$$\text{SF: } \left| \frac{c \cdot t}{2} \cos(\psi + \alpha) - R_c \right| < R_a \quad \wedge \quad \left| \frac{c \cdot t}{2} \sin(\psi + \alpha) - X_c \right| < X_a \quad (16)$$

The SAS signal has to be set to zero beyond the SF area. The manner of the spatial filtering was depicted in Figure 3. Actually, the presented diagram should be supplemented with the options of upsampling and down-sampling in the  $\mathbf{x}'$  domain because of a wider bandwidth of  $e_p(\mathbf{x}', \omega)$ . However, if we divide the synthetic aperture into small enough

subapertures it will be possible to do without these operations. Then, the bandwidth of  $e_p(\mathbf{x}', \omega)$  becomes nearly the same as the  $e(\mathbf{x}', \omega)$  signal.

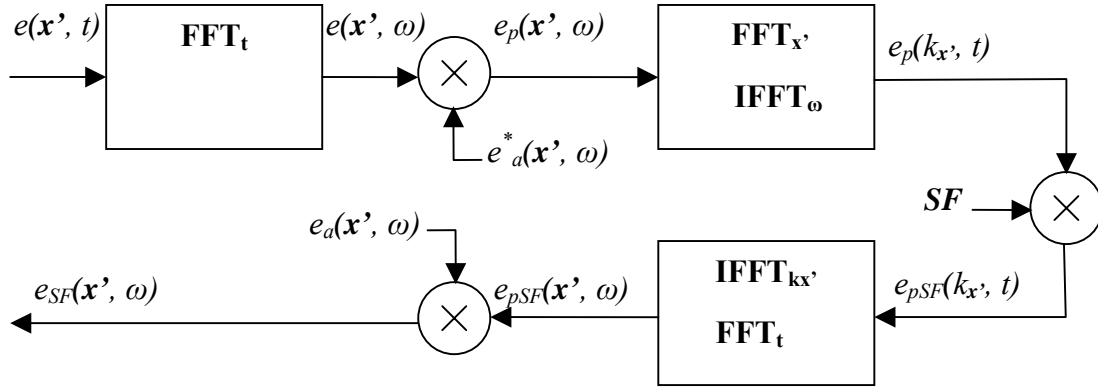

Fig.3 Spatial filtering algorithm

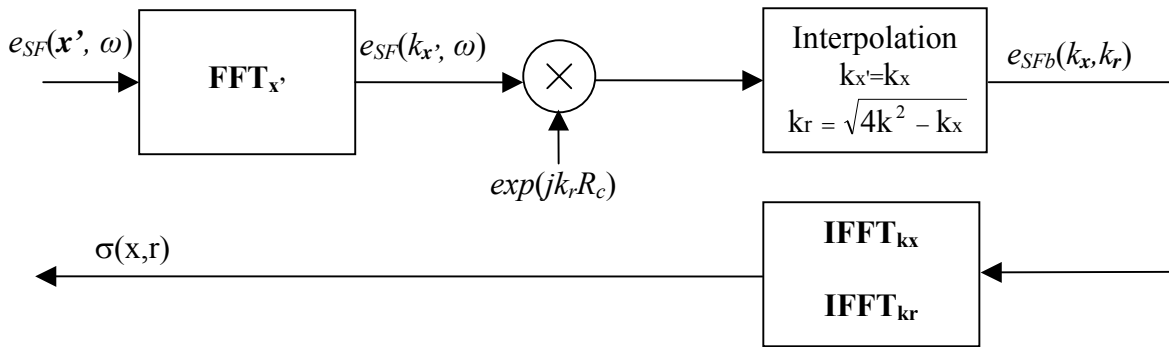

Fig.4 Omega-k algorithm

### 3. OMEGA-K ALGORITHM

The final image of the examined seafloor is obtained with the use of the Omega-k algorithm depicted in Figure 4. It was assumed that  $X_c=0$  what is referred to as a broadside case. Otherwise, we should introduce the additional phase term (taking into consideration a squint case) which  $e_{SF}(k_x, \omega)$  has to be multiplied by. The wavenumber algorithm is not subject of this paper (however used in the simulation), therefore details are not discussed here. More particulars can be found in [3] by author.

### 4. NUMERICAL SIMULATION

The case of the broadside SAS system (where  $X_c=0$ ) was used to examine spatial filtering of the SAS signal. The assumed parameters of the system were listed below (tab. 1). The chirp signal was applied for the purposes of this simulation. Figure 5A shows the echoes from 9 scatterers where only 4 contributions come from the target area and should appear in the processed image. The cause of appearing the undesirable contributions situated beyond TA is the finite antenna bandwidth (Equation 13). The aim of SAS processing is to filter out

unwanted contributions and focus the energy in both the azimuth and the range directions. The first step was the range compression (5B) which made the SAS signal appropriate to further processing. Then the spatial filtering with the use of the polar format processing was applied (5C), after that the final SAS image was obtained by the Omega-k algorithm (5D). We can see that the resultant image contains only the desirable well-focused targets.

Tab.1 Assumed parameters of SAS system.

velocity of platform	0.5[m/s]
c (sound speed in water)	1500[m/s]
chirp bandwidth	5[kHz]
chirp duration	5[ms]
carrier frequency	100[kHz]
sonar diameter in the azimuth direction	0.16[m]
range resolution	0.0750[m]
azimuthal resolution	0.0800[m]
$2 \cdot R_a$ (examined seafloor in the range direction)	20[m]
$2 \cdot X_a$ (examined seafloor in the azimuth direction)	10[m]
$R_c$ (distance to the center of the examined area)	30[m]

Actually, in order to achieve this effect the synthetic aperture was divided into four parts so-called subapertures. On the one hand, it is recommended to use subapertures as small as possible. This solution has two advantages. First, we don't have to upsample the received SAS data. Second, spatial filtering becomes more precise because of the range migration reduction in small subapertures. On the other hand, the usage of too small subapertures is equivalent to apply too short rectangular window. Therefore, the choice of the subaperture size is a kind of tradeoff. The result of applying only two subapertures is shown in Figure 5E. The scatterer at the edge of the examined area is fuzzy. In addition, a part of the outside scatterer signature got inside. The SAS image after the polar format processing in comparison with the ideal SAS signal (no undesirable contributions and spatial filtering, 5F) is only slightly different. The main difference lies in the fact that the sidelobes of the point spread function appears more dominant in the first one (compare 5D with 5F).

## 5. CONCLUSIONS AND REMARKS

Spatial filtering of the SAS signal was examined. The undesirable contributions (beyond the target area) were filtered out with the help of the polar format processing and then, the wavenumber algorithm was applied as the reconstruction method. It turned out that the sidelobes of the point spread function become more dominant in the resultant image in comparison to the ideal case where unwanted contributions did not occur at all.

Surely, spatial filtering could be improved by applying a few modifications of the presented processing. For the purpose of this improvement it's possible to withdraw the narrow-bandwidth assumption. However, the wide-bandwidth case requires an additional interpolation in the polar formatting and depending on the SAS system parameters (bandwidth and carrier frequency) this operation becomes more or less justifiable.

It was shown that in case of inappropriate choice of the subaperture size some targets near to the edges of the resultant image appeared fuzzy (the narrow-bandwidth approximation

may cause a similar effect). On the other hand, too small subapertures result in spreading of the point spread function. A simply idea is just to use a larger spatial filter and then to discard the poor quality parts of the resultant SAS image.

The simulation proved the validity of the usage of the polar format processing in spatial filtering.

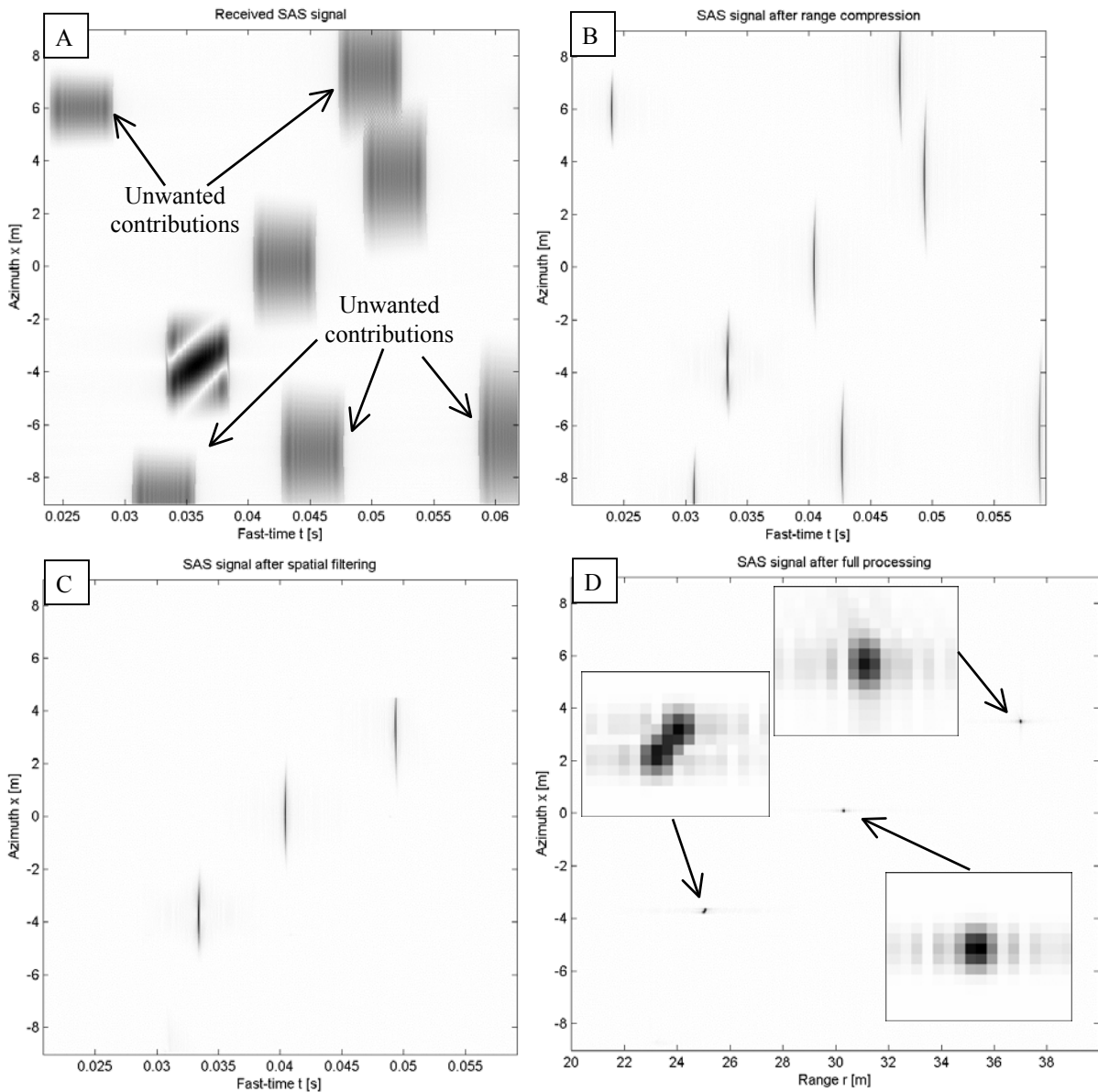

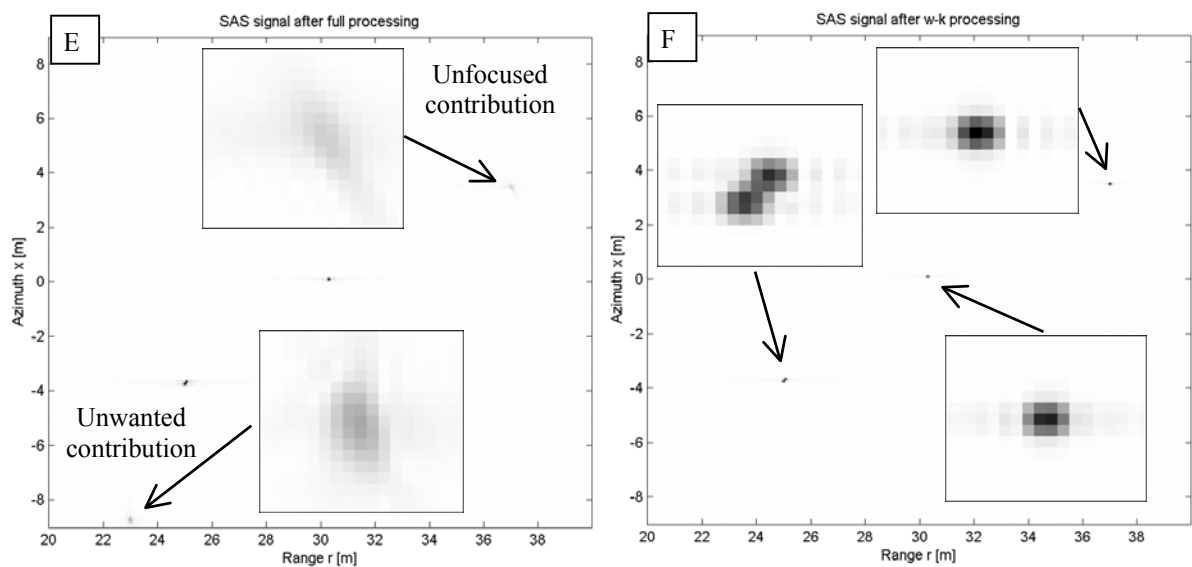

Fig.5 Some results of the simulation

#### REFERENCES

- [1] W. Bonifant, Interferometric synthetic aperture sonar processing, Thesis, 38-39, Georgia Institute of Technology 1999.
- [2] M. Soumekh, Synthetic aperture radar signal processing, John Wiley & Sons, 239-242, USA 1999.
- [3] M. Szczegielniak, Przetwarzanie danych sas przy pomocy algorytmu OMEGA-K, Otwarte Seminarium z Akustyki, Poznań-Wągrowiec 2005.