

# **ELECTRONIC STABILIZATION OF BEAMS IN SONAR WITH CYLINDRICAL ARRAY**

JACEK MARSZAL, WOJCIECH LEŚNIAK, ROMAN SALAMON,  
JAN SCHMIDT

Gdansk University of Technology,  
Faculty of Electronics, Telecommunications and Informatics,  
Department of Marine Electronic Systems  
Narutowicza 11/12, 80-952 Gdansk  
marszal@eti.pg.gda.pl

*The article presents the principle of operation of the beamformer of sonar with a cylindrical array. It demonstrates that a modified beamformer can be used for beam electronic stabilization. The paper presents the algorithm of a digital beamformer used to ensure that the beam's axis is maintained in a horizontal plane when the ship's pitch and roll are known. Finally, the article gives an overview of the technical problems of electronic beam deflection.*

## **INTRODUCTION**

As the ship's hull moves on the waves, sonar beams change their position in space. Narrow beam sonars require *beam stabilization*, a solution to ensure that beam position is independent of the ship's movements. There are two basic stabilization methods, *antenna position stabilization* and *beam electronic stabilization*. In both methods the momentary position of the ship's hull with the sonar antenna must be known. Gyro-horizon and gyro-compass are used to measure the angles between the hull, the horizontal plane and the north. Gyro signals are processed and used either in an automation system, which compensates antenna tilts or in a specialist beamformer, which causes the beam to deflect and/or rotate.

The article presents the principle of operation of an electronic stabilization beamformer with a cylindrical antenna. The beamformer compensates for the ship's pitch and roll, and the rotation caused by yawing and change of course is compensated for in sonar imaging.

## 1. PRINCIPLE OF OPERATION OF A BEAMFORMER WITH A CYLINDRICAL ANTENNA

The cylindrical antenna is built of  $M$  number of columns, spaced evenly every  $\phi$  degrees on the lateral surface of an  $R$  ray cylinder. The column is made up of  $P$  transducers, whose geometric centres of the radiant surface are spaced at  $l$ . Fig. 1 shows simplified antenna geometry.

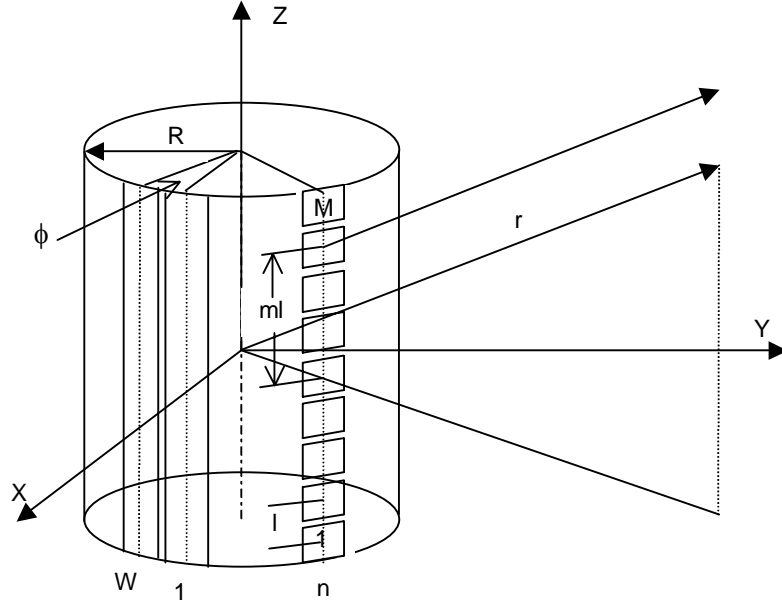

Fig.1 Geometry of cylindrical antenna

Let us assume that there is a very long distance  $r$  between the source of the acoustic wave and the centre of the cylinder, and the angles  $\theta$  and  $\phi$  define the position. The source's coordinates in rectangular coordinates are equal to:

$$x = r \sin \theta \quad y = r \cos \theta \quad z = r \sin \phi \quad (1)$$

Let us consider a transducer lying on the cylinder's surface with the following coordinates of the centre:

$$x_a = R \sin(n\alpha) \quad y_a = R \cos(n\alpha) \quad z_a = ml \quad (2)$$

The distance  $d$  between the source and the centre of the transducer selected is:

$$d = \sqrt{(x - x_a)^2 + (y - y_a)^2 + (z - z_a)^2} \quad (3)$$

The coordinates of the antenna's central transducer are equal to  $x_0=0$ ,  $y_0=R$ ,  $z_0=0$ , and the distance  $d_0$  between the source and the transducer's centre is equal to:

$$d_0 = \sqrt{x^2 + (y - R)^2 + z^2} \quad (4)$$

Formulas (3) and (4) give us the difference of the squares of these distances:

$$d^2 - d_0^2 = -2xx_a + x_a^2 - 2yy_a + y_a^2 - 2zz_a + z_a^2 + 2yR - R^2 \quad (5)$$

Because  $x_a^2 + y_a^2 = R^2$ , and following the substitutions, we obtain:

$$d^2 - d_0^2 = -2rR[\sin \theta \sin(n\phi) + \cos \theta \cos(n\phi)] - 2rR \cos \theta - 2rml \sin \phi + (ml)^2 \quad (6)$$

Next, using the known trigonometric relation, we obtain:

$$d^2 - d_0^2 = 2rR[\cos \theta - \cos(\theta - n\phi)] - 2rml \sin \phi + (ml)^2 \quad (7)$$

For a small difference in the distances  $\Delta d = d - d_0$ , the above difference of the distance squares can be expressed in a simplified form as:

$$d^2 - d_0^2 = (d - d_0)(d + d_0) \cong 2\Delta d d_0 \cong 2\Delta d r \quad (8)$$

When the relation is inserted into formula (6) and following the simplification, we obtain:

$$\Delta d \cong R[\cos \theta - \cos(\theta - n\phi)] - ml \sin \varphi + (ml)^2 / 2r \quad (9)$$

Where the distance between the source and antenna grows to infinity, the last term goes to zero and finally we obtain:

$$\Delta d \cong R[\cos \theta - \cos(\theta - n\phi)] - ml \sin \varphi \quad (10)$$

Let us now assume that the source is emitting a sinusoidal spherical wave with pulsation  $\omega_0$ . The wave number is then equal to  $k = \omega_0 / c_0$  and the acoustic pressure of a wave falling on the centre of the surface of the transducer in question can be written as:

$$p(d, t) = \frac{Q}{d} e^{j(\omega_0 t - kd)} = \frac{Q}{d} e^{j[\omega_0 t - k(d_0 + \Delta d)]} = \frac{Q}{d} e^{j(\omega_0 t - kd_0)} e^{-jk\Delta d} \quad (11)$$

where  $Q$  is the constant depending on the pressure of the wave emitted by the source.

The first term of the above formula describes the sinusoidal wave falling on the centre of the central transducer. Wave pressure will be determined as:

$$p_0 = p(d_0, t) = \frac{Q}{d} e^{j(\omega_0 t - kd_0)} \quad (12)$$

Therefore, we obtain:

$$p(d, t) = p_0 e^{-jk\Delta d} \quad (13)$$

The pressure phase of a wave falling on the transducer in question is shifted compared to the phase of the wave falling on the central transducer. The size of the shift is the exponential function exponent and is obtained by inserting expression (10) into the above formula:

$$p(d, t) \cong p_0 e^{-jkR[\cos \theta - \cos(n\phi - \theta)]} e^{-jkm l \sin \varphi} \quad (14)$$

The above formula shows an important feature of the phase shift: phase shift in connection with angle  $\theta$  (in the horizontal plane) is solely dependent on the angular position of the transducer in the horizontal plane, and phase shift in connection with angle  $\varphi$  depends solely on the position of the transducer in the vertical plane. In other words, all transducers aligned in a single column have the same phase shift as for angle  $\theta$ , and all transducers in a single row have identical phase shift for angle  $\varphi$ . Consequently, beams can be controlled independently in the horizontal and vertical plane. By determining the electric signal at transducer output number  $n m$  as  $s(n, m)$  we obtain <sup>1</sup>:

$$s(n, m) = S_0 s(n) s(m) \quad (15)$$

where

$$s(n) = e^{-jkR[\cos \theta - \cos(n\phi - \theta)]} \quad (16)$$

$$s(m) = e^{-jkm l \sin \varphi} \quad (17)$$

Both formulas describe the phase shift of a sinusoidal signal with frequency  $f_0 = \omega_0 / 2\pi$ , in connection with wave incidence direction and transducer number.

To generate a beam at a specific angle, phase compensation must be conducted [2]. In beamformers with cylindrical antennas, beam axes in the horizontal plane are perpendicular to

<sup>1</sup> We neglect the effect of finite transducer aperture.

the surface of transducers in the subsequent antenna columns. Phase compensation in the horizontal plane comes down to a multiplication of signals  $s(n,m)$  by coefficients  $w(n)$  equal to:

$$w(n) = e^{jkR[1-\cos(n\phi)]} \quad (18)$$

In the vertical plane phase compensation is performed for a specific deflection angle  $\varphi_0$ . Coefficients  $v(m)$ , by which signal  $s(n,m)$  is multiplied, have the following form:

$$v(m) = e^{jkm l \sin \varphi_0} \quad (19)$$

The algorithm for determining the signal at the output of a deflected beam can be written as:

$$S(0, \varphi_0) = \sum_{n=-N}^N \sum_{m=-M}^M s(n,m)w(n)v(m) = \sum_{n=-N}^N w(n) \left[ \sum_{m=-M}^M s(n,m)v(m) \right] \quad (20)$$

The above algorithm can be used for beam stabilization.

## 2. GEOMETRIC RELATIONS IN THE BEAM STABILIZATION SYSTEM

In electronic beam stabilization the idea is to continuously bring the axes of the beams to the horizontal plane. To achieve this, beamformer coefficient values  $v(m)$  are changed. The coefficients are calculated as part of sonar processes based on gyro-horizon signals. The gyro-horizon generates signals, which are proportional to two angles, i.e.:

- angle  $\alpha$  between the ship's axis and the axis' vertical projection on the horizontal plane,
- angle  $\beta$ , which is the angle between the ship's transverse axis, the projection of the axis across a plane perpendicular to the deck onto the vertical plane.

In other words, angle  $\alpha$  lies in the vertical plane, and angle  $\beta$  - in the plane perpendicular to the deck. The situation is illustrated in Fig.2.

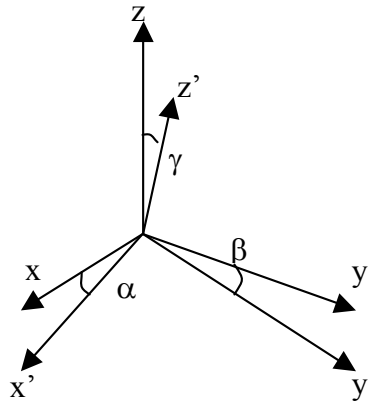

Fig.2 Angles of antenna tilt towards the horizontal plane

The position of axes  $x,y,z$  determines the position of the horizontal plane  $x,y$ . The system of axes  $x',y',z'$  is related to the ship and plane  $x',y'$  is the plane of the deck. The axis of the cylindrical antenna is parallel to axis  $z'$ . The antenna columns are in a fixed position towards  $x',y',z'$  and change the position as the ship's deck tilts compared to  $x,y,z$ . Angles  $\alpha$  and  $\beta$  are known, because these values are measured with the gyro-horizon. As we said earlier, we

assume that the ship does not rotate. Sonar beams rotation is compensated for after the beam-former in sonar imaging.

Our task is to identify the relation between angles  $\alpha$  and  $\beta$  and phase shifts in the beam-former, which deflects beams in the vertical plane, i.e. in the plane traversing axis  $z'$ . To that end, the coordinates of antenna elements should be expressed using coordinates  $x, y, z$ .

Because of the significance of angles  $\alpha$  and  $\beta$ , moving the coordinates  $x', y', z'$  to a new position should be done in two stages:

- to rotate the coordinates  $x', y', z'$  against axis  $y$  expressed with angle  $\alpha$ ,
- to rotate the new system against the new position of axis  $x'$ .

By following this rule, coordinates  $x, y, z$  depend on coordinates  $x', y', z'$  as follows:

$$\begin{bmatrix} x \\ y \\ z \end{bmatrix} = \begin{bmatrix} l_1 & l_2 & l_3 \\ m_1 & m_2 & m_3 \\ n_1 & n_2 & n_3 \end{bmatrix} \cdot \left( \begin{bmatrix} l_{1'} & l_{2'} & l_{3'} \\ m_{1'} & m_{2'} & m_{3'} \\ n_{1'} & n_{2'} & n_{3'} \end{bmatrix} \begin{bmatrix} x' \\ y' \\ z' \end{bmatrix} \right) \quad (21)$$

where matrix coefficients are direction cosines of angles  $\alpha$ ,  $\beta$  and  $\gamma$  which result from the above rotations. The brackets show the sequence of matrix multiplication. Hence we obtain:

$$\begin{bmatrix} x \\ y \\ z \end{bmatrix} = \begin{bmatrix} \cos \alpha & 0 & \sin \alpha \\ 0 & 1 & 0 \\ \sin \alpha & 0 & \cos \alpha \end{bmatrix} \cdot \left( \begin{bmatrix} 1 & 0 & 0 \\ 0 & \cos \beta & \sin \beta \\ 0 & \sin \beta & \cos \beta \end{bmatrix} \begin{bmatrix} x' \\ y' \\ z' \end{bmatrix} \right) \quad (22)$$

When the second matrix is multiplied by the vector we obtain:

$$\begin{bmatrix} x \\ y \\ z \end{bmatrix} = \begin{bmatrix} \cos \alpha & 0 & \sin \alpha \\ 0 & 1 & 0 \\ \sin \alpha & 0 & \cos \alpha \end{bmatrix} \cdot \begin{bmatrix} x' \\ y' \cos \beta + z' \sin \beta \\ y' \sin \beta + z' \cos \beta \end{bmatrix}, \quad (23)$$

and then, finally

$$\begin{bmatrix} x \\ y \\ z \end{bmatrix} = \begin{bmatrix} x' \cos \alpha & + & \sin \alpha (y' \sin \beta + z' \cos \beta) \\ y' \cos \beta + z' \sin \beta \\ x' \sin \alpha & + & \cos \alpha (y' \sin \beta + z' \cos \beta) \end{bmatrix} \quad (24)$$

The above relations are the relations we sought between the coordinates of both coordinate systems.

Let the axis of the cylindrical antenna beam be deflected from axis  $x'$  by angle  $\delta$ . The axis equation has the following form:

$$x' = R \cos \delta \quad y' = R \sin \delta \quad z' = 0 \quad (25)$$

In coordinates  $x, y, z$  we will obtain the beam axis equation by inserting the above relations into equation (24). Hence we obtain:

$$\begin{bmatrix} x \\ y \\ z \end{bmatrix} = R \begin{bmatrix} \cos \delta \cos \alpha & + & \sin \delta \sin \alpha \sin \beta \\ \sin \delta \cos \beta \\ \cos \delta \sin \alpha & & \sin \delta \cos \alpha \sin \beta \end{bmatrix} \quad (26)$$

It is an equation of a straight line going through the centre of a coordinate system, parallel to a certain vector  $\mathbf{R}$ , whose direction cosines are equal to:

$$\begin{bmatrix} l \\ m \\ n \end{bmatrix} = \begin{bmatrix} \cos \delta \cos \alpha & + & \sin \delta \sin \alpha \sin \beta \\ \sin \delta \cos \beta \\ \cos \delta \sin \alpha & & \sin \delta \cos \alpha \sin \beta \end{bmatrix} \quad (27)$$

The beam's axis can be brought to the horizontal plane by compensating for phase  $\varphi$ , when the phase meets the following equation:

$$\cos \varphi = ll' + mm' + nn' \quad (28)$$

where  $l'$ ,  $m'$ ,  $n'$  are direction cosines of the beam's axis in the horizontal plane.

The cosines have the following values:

$$l' = \cos \delta \quad m' = \sin \delta \quad n' = 0 \quad (29)$$

Hence we obtain:

$$\cos \varphi_0 = \cos^2 \delta \cos \alpha + \cos \delta \sin \alpha \sin \beta + \sin^2 \delta \cos \beta \quad (30)$$

Angle  $\varphi_0$  determined from the equation should be inserted into formula (19) to allow the determination of coefficients  $v(m)$ , to be followed by mathematical operations based on beamformer algorithm (20). As a result, the beam's axis will tilt in relation to the cylindrical antenna's axis and the beam's axis will be positioned on the horizontal plane. Consequently, the beam will be stabilized, which is the objective of the system in question.

### 3. TECHNICAL PROBLEMS OF BEAM STABILIZATION

Cylindrical antenna sonars fall into two groups, i.e. sonars that generate beams deflected both in the horizontal and vertical plane and those generating beams deflected in the horizontal plane only. In the first case there is no need to significantly extend the sonar to introduce electronic beam stabilization. Stabilization is achieved by an ongoing adjustment of coefficients  $v(m)$ , while the other operations remain unchanged. The receiver's analogue electronic systems do not require any extensions either. Electronic beam stabilization in these sonars is the best solution, both from a technical and economic perspective.

Before electronic beam stabilization can be used in sonars generating beams in the horizontal plane only, the receivers must be significantly extended and digital beamformer processing capacity increased several times. Here is an example. Let us assume that the sonar's receiver generates  $W=60$  beams  $6^\circ$  wide in the horizontal plane. Consequently, the cylindrical antenna is built of  $W$  transducer columns. To generate one beam  $2N+1=21$  antenna columns must be used. To determine  $W$  beams we must perform  $W(2N+1)$  multiplications for one complex sample in each beam. In this example, the number of multiplications is 1260. If the width of the beam in the horizontal plane is also equal to  $6^\circ$ , the number of transducers in each antenna column is also  $2M+1=21$ . To stabilize the beam in the vertical plane  $W(2N+1)(2M+1)$  multiplications of complex numbers would have to be performed. The processor must be  $2M$  times more powerful in the sonar with no electronic beam stabilization. In the example in question the processing power should increase 20 times. In addition, the receiver's analogue part needs extending, because the number of channels must increase 20 times as well. As a result, the sonar's design can generate beams deflected in the horizontal and vertical plane, which makes it high-end sonar, part of the first group of sonars.

In summary [1], the decision to use electronic beam stabilization in horizontal beam sonars must be weighed against a possibly simpler and cheaper solution, i.e. mechanical antenna stabilization.

### REFERENCES

- [1] J. Marszal, R. Salamon, A. Stepnowski, Military Sonar Upgrading Methods Developed at Gdansk University of Technology, IEEE Oceans'05 Europe - Conf. Proc., Brest 2005.
- [2] R. Salamon, Systemy hydrolokacyjne, Wyd. Gdańskie Tow. Naukowe, Gdańsk 2006.