

# PROCESSING THE COMPLEX SIGNAL IN THE ACOUSTIC PROCESSOR OF A SONOBUOY SYSTEM

ALEKSANDRA RAGANOWICZ, MARIUSZ RUDNICKI, ROMAN SALAMON

Department of Marine Electronics Systems, Faculty of Electronics, Telecommunications and Informatics, Gdansk University of Technology  
Narutowicza 11/12, 80-952 Gdansk, Poland  
e-mail: ragola@eti.pg.gda.pl

*The article presents digital methods for processing the complex signal in the acoustic processor of a sonobuoy. The overall system design and the complex signal are presented. Two alternative methods for signal processing are discussed: in the time domain and in the frequency domain. Block diagrams of the algorithms of both processing methods are included. The problems involved in the practical implementation of data analysis methods are discussed. The problems are produced by the phenomena occurring in the system's analogue section and by the complexity of the computation related to how powerful the digital algorithms are. The computation errors in both methods are analysed. The advantages and disadvantages of the different signal processing methods are discussed, with emphasis on the practicality of the device. The advantage of the processing method in the frequency domain is explained. Graphic images of the results of both processing methods are included on the example of real signals received during the study.*

## 1. GENERAL SONOBUOY SYSTEM CHARACTERISTICS

The sonobuoy system in question consists of three elements: a sonobuoy, VHF receiver, acoustic processor, a visualisation panel and manipulators. Figure 1 shows the block diagram of the system.

The system works as follows. As acoustic waves propagate in water, they are received by a set of sonobuoy hydrophones. They are then transmitted by radio to a radio signal receiver and transformed to become a complex signal at receiver output. The complex signal carries information about the wave's original direction. It is then fed to the analogue input of the acoustic processor for further digital processing.

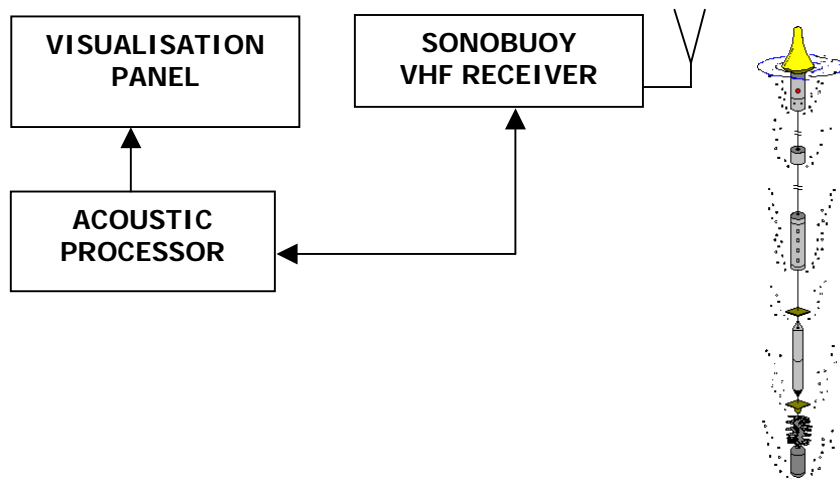

Fig.1 Block diagram of the sonobuoy system

## 2. GENERAL FORM OF THE COMPLEX SIGNAL

The complex signal at the VHF receiver's output is made up of three signals, which are essential for detecting and estimating direction. They are: the central *S* hydrophone signal and the carrier signal, modulated with differential *D13* and *D24* signals. The complex signal carries additional information about the angle North of antenna rotation. A compass included in the antenna system measures the angle. The general form of the complex signal is presented in Figure 2.

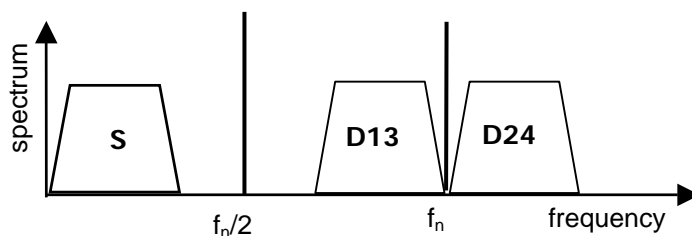

Fig.2 General form of the complex signal

## 3. COMPLEX SIGNAL PROCESSING IN THE ACOUSTIC PROCESSOR

In the majority of systems radio receivers have a module-based design. The modules are responsible for radio signal demodulation. Complex signals from the sonobuoys are fed to the outputs of the modules. Complex signals in each of the processor's channels are processed in exactly the same way. The first stage of processing involves analogue to digital conversion. The sampling frequency should be consistent with the Nyquist criterion, and in the system in question it should be higher than 36 kHz. To facilitate calculation, the frequency should be set at the power of 2, making the FFT algorithm possible without having to supplement the sequence of samples with zeros. In the system in question the frequency could be set at 65536 Hz, i.e.  $2^{16}$ .

The complex signal can be processed both in the time and frequency domain. Both methods are equivalent and yield similar results. When selecting a method, the practical aspects should be

considered, i.e. the processing algorithms, the resources and how powerful the equipment used for designing the acoustic processor is.

#### 4. TIME DOMAIN PROCESSING

Time domain processing performs all the functions of an analogue processor. The relevant algorithm is shown in Figure 3. The complex signal  $x(t)$  is fed to the processor's input. It is then filtered in digital filters. The first filter with mid-band frequency at  $f_n/2$  generates a signal with information about the angle of antenna deflection from the North. The next filter has mid-band frequency  $f_n$  and bandwidth at about 6 kHz and generates a narrowband signal modulated with differential signals. The third lowpass filter generates a signal from the central hydrophone. In the next stage of processing signal  $f_n/2$  is squared and then filtered in a narrowband filter with mid-band frequency  $f_n$ . The signal at the filter's output is phase shifted from the original sinusoidal keying signal by angle  $\Theta_0$  of antenna deflection from the North. The orthogonal signal of the same phase shift is obtained at the output of the Hilbert transformer, marked as HT in the Figure. The narrowband signal with mid-band frequency  $f_n$  is multiplied by the sinusoidal and cosine signal. Following lowpass filtration, the result is separate differential signals. If no noise is present, the amplitudes of these signals are proportional to the sine and cosine of the wave incidence angle North. Fourier transform is calculated from each of the three signals. The three transforms are the basis for determining the direction of wave origination.

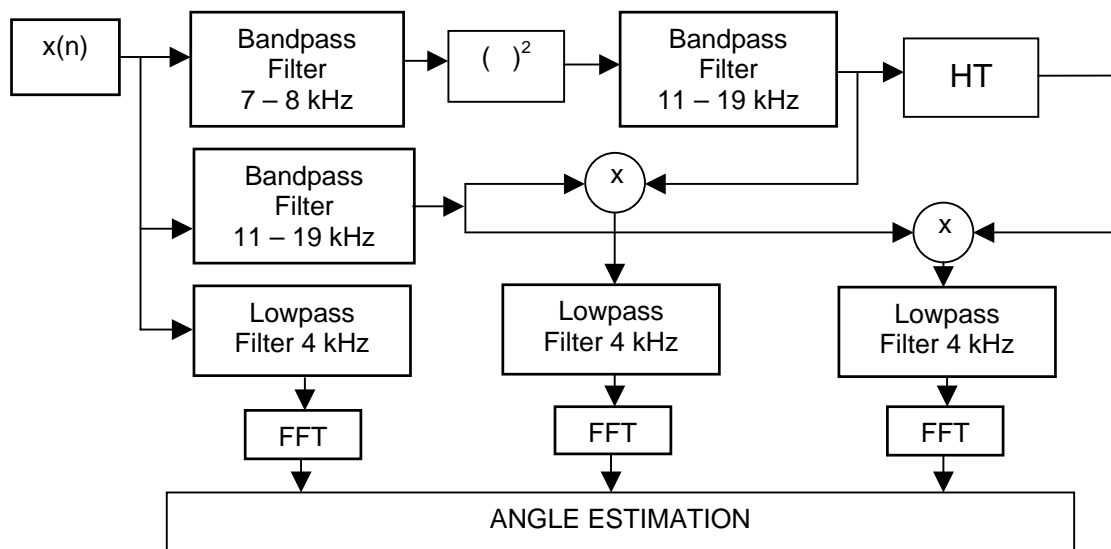

Fig.3 Time domain processing algorithm

#### 5. FREQUENCY DOMAIN PROCESSING

Frequency domain processing offers an alternative method. Unlike the above method, in frequency domain processing there is no need for complex signal reconstruction, and simple signal spectrum operations are sufficient. The algorithm includes the following operations:

1. the sequence of samples  $x(n)$  is multiplied by the Blackman-Harris window function (to reduce the side lobes produced when calculating Fourier transform),
2. the signal's Fourier transform is calculated  $y(n)$ ,

3. the lines of the acoustic signal from the central hydrophone  $S$  are isolated from the Fourier transform (equivalent of lowband filtration in the time domain),
4. the component lines of differential signals  $D13$  and  $D24$  are isolated (equivalent of narrowband filtration in the time domain),
5. the lines of the narrowband signal  $X_m$  with mid-band frequency  $f_n$  are isolated from the Fourier transform (equivalent of narrowband filtration in the time domain),
6. the convolution of the narrowband spectrum of signal  $X_m$  with the spectra of differential signals  $D13$  and  $D24$  is calculated,
7. the product of the central hydrophone signal's spectrum and the spectrum of the signal following the convolution is calculated,
8. the wave incidence angle North is calculated.

Figure 3 shows the block diagram of the algorithm.

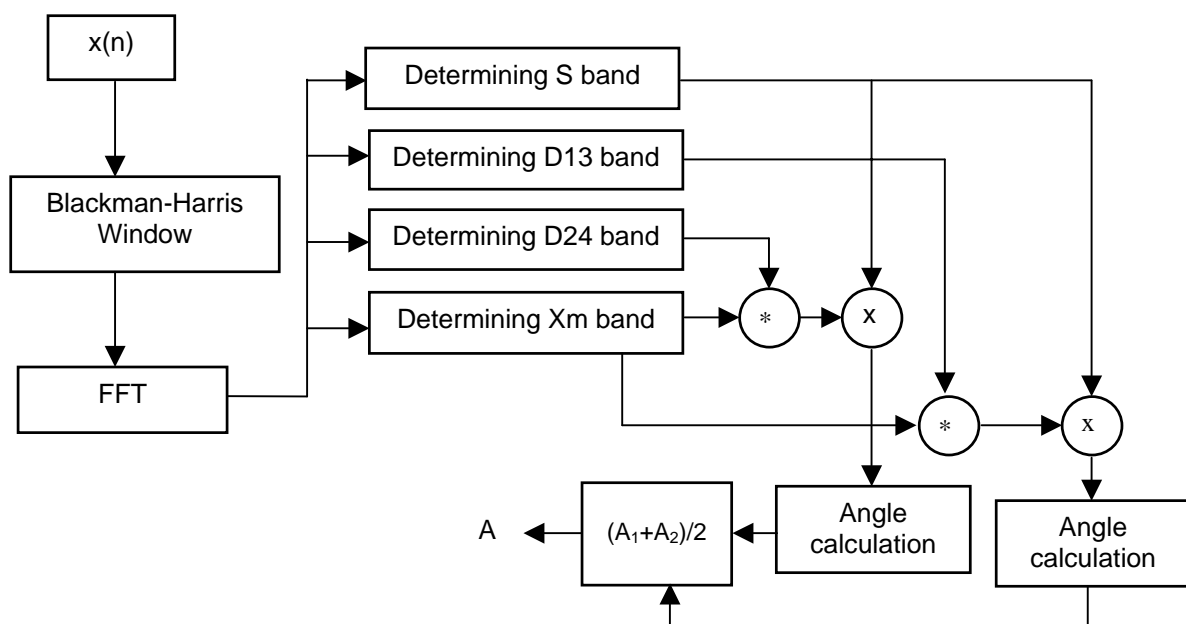

Fig.4 Algorithm of frequency domain processing

## 6. PROBLEMS WITH THE PRACTICAL IMPLEMENTATION OF BOTH METHODS

The choice of the processing method depended on how well it could be implemented using the equipment designed and developed for this purpose.

The time domain processing method draws on the concept of the analogue system. It requires a big number of numerical operations. The digital filters used in this method should have linear phase characteristics and adequately steep slopes, which in effect means that high order FIR filters have to be used. Their algorithms, however, are significantly complex to compute. The alternative is application IIR filters in combination with the sequence reversal method, which doubles the number of numerical operations. Using same order filters makes the method a lot easier, because it eliminates the need to synchronise signals after filtration. The next cumbersome stage of time domain processing is Hilbert transformer. In simulations of the system's algorithms the Fourier transform and simple spectrum operations were used. It is general knowledge that in practice the most common Fourier transform algorithm is the FFT algorithm, but using it imposes serious limitations on the input signal. In practice using the FFT algorithm to implement the algorithm of Hilbert transformer is not quite successful. The transformer will work well only if the sequence of

samples includes a complete number of periods of the measurement signal for which we want to determine the orthogonal component. Otherwise, the signal after Hilbert transformer is not orthogonal. Another method for reconstructing the cosine signal is to use a Hilbert transformer, that works in the time domain, described with the following formula:

$$h(m) = \begin{cases} 0, & m = (M + 1) / 2 \\ \frac{2 \cdot \sin^2\{\pi / 2[m - (M + 1) / 2]\}}{\pi \cdot [m - (M + 1) / 2]}, & m = \{0..M\} - \{(M + 1) / 2\} \end{cases}$$

In this case, the cosine component is determined by simply calculating the convolution function between the sequence of samples of the phase shifter and the sinusoidal signal. The accuracy of the algorithm depends on the length of the sequence describing the shifter function. The longer the sequence, the more accurate the representation of the orthogonal component, and, on the other hand, the bigger the number of numerical operations required. The disadvantage of introducing a bigger number of shifter function samples is that non-stationary states at the beginning and end of the cosine component become longer. As a result, an additional operation is required to synchronise the sinusoidal and cosine components.

Other problems with the practical implementation of complex signal time domain processing have to do with the structure of the equipment used for the design of the acoustic processor.

Each data processing block comprises 11 DSP processors, grouped in clusters. The processors and sub-groups are linked together with fast links, which the producer calls link-ports. The links are designed to enable a fast exchange of information between the processors involved in the different stages of the algorithm. The blocks have a dedicated operating system REMIX. It facilitates communications between the processors, and uses only a small portion of the processor's power and memory. This feature of the operating system suggests that computation can be shared by the processors. The problem, however, is that the system's communications functions can only support data transfer but cannot check the accuracy of the data transmitted. This function is performed outside the system. What this can mean in practice is that the system uses a large portion of the processor's capacity to steer and control data transmission, which is bad for processing.

From the processing perspective, static memory, used for storing measurement data, is another difficult issue. It is particularly important when listening time is prolonged and the volume of data increases in direct proportion to the length of time. Unfortunately, in the dedicated packages only four of eleven processors have sufficient SRAM memory 4Mx32b. This is why they have to take on the majority of numerical operations. The other processors are used for simple data compression operations and data transmission only. It needs to be noted that the natural unit of DSP processors memory capacity is the 32-bit word. The DSP computational units used in the acoustic processor only have 128kx32b of their own SRAM memory, while to save samples of a one second complex signal with sampling frequency at 65536, 64kx32b is needed, i.e. half of the available memory.

Frequency domain processing is clearly less problematic. The limitation of this method is the memory it needs to store input and output data for calculating the Fourier transform. However, when this operation is finished, those parts of the memory where input data were stored, can now be used for storing the interim results. In addition, frequency domain processing involves fewer numerical operations on fewer data and fewer interim results are stored.

Another factor which has an effect on the speed of processing, and one which should be considered when implementing the algorithms, is the use of the DSP processor architecture. These processors have duplicate groups of registers and buses of programme and data memory. If the data are properly distributed the architecture in one clock cycle gives access to both arguments of an operation. Another important factor influencing processing speed is using the processor in the

SIMD mode (*Single Instruction Multiple Data*), where an operation is carried out on two successive sets of arguments in one clock cycle.

## 7. COMPUTATIONAL ERRORS

Complex signal processing, i.e. determining the wave incidence angle, comes with two types of error. The first type of error has to do with what happens during the operation of the analogue part of the system. How accurate the computed direction is depends primarily on the signal to noise ratio. Another source of errors is clearly the instability of the carrier frequency of differential signals. As was mentioned before, this phenomenon has a negative effect on frequency domain processing and the spectrum convolution function must be used. If this phenomenon did not occur, the convolution could be replaced with one spectral line multiplication. Another source of errors is the accuracy of sinusoidal and cosine signals reproduction. As it was mentioned before, the amplitudes of these signals, if the signal to noise ratio is high enough, are proportionate to the sinus and cosine of the wave incidence angle North.

The second type of errors are computational errors, caused by the finite length of a word of data, used by the computational unit. Because of the speed, acoustic processors mainly use operations on 32-bit data. However, all constants and coefficients used in the algorithm are computed from double precision data (64-bits), and it is the final value that is stored on 32 bits. This approach eliminates to the minimum errors, which are the result of single precision data, and significantly speeds up the algorithm. When the results of 32 and 64-bit data computations were compared, the differences were after four decimal places.

## 8. RESULTS OF MEASUREMENTS

The images below show the results of simulations and real system operation. The four illustrations below show the results of a simulation on a real test signal, sampled in the acoustic processor, which has 10 independent frequencies with different bearings, constant in time. The results show four different times of listening operations.

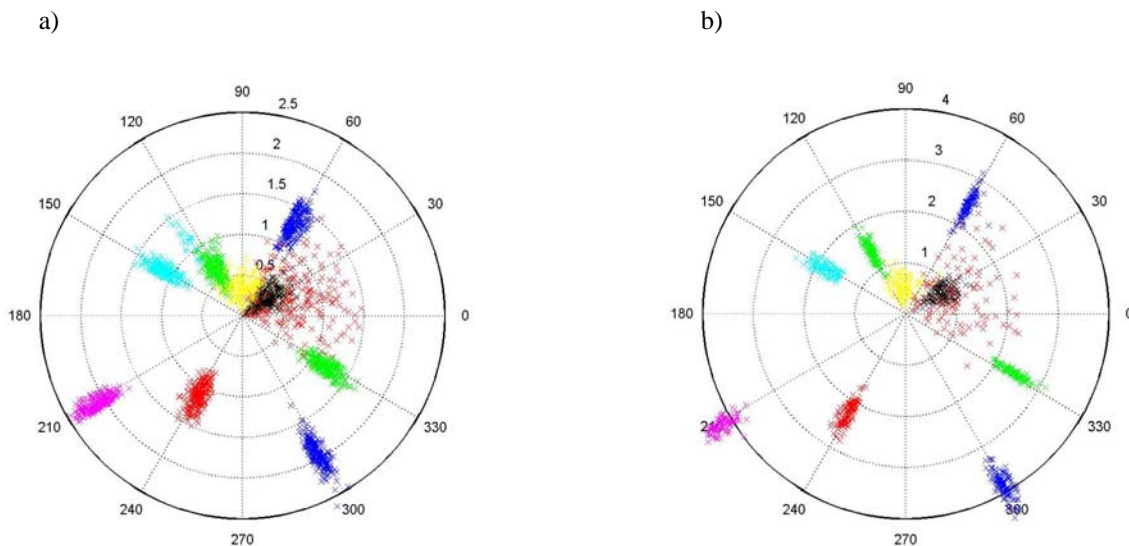

Fig.5 The computed bearings; a) time of listening 1s, b) time of listening 2s

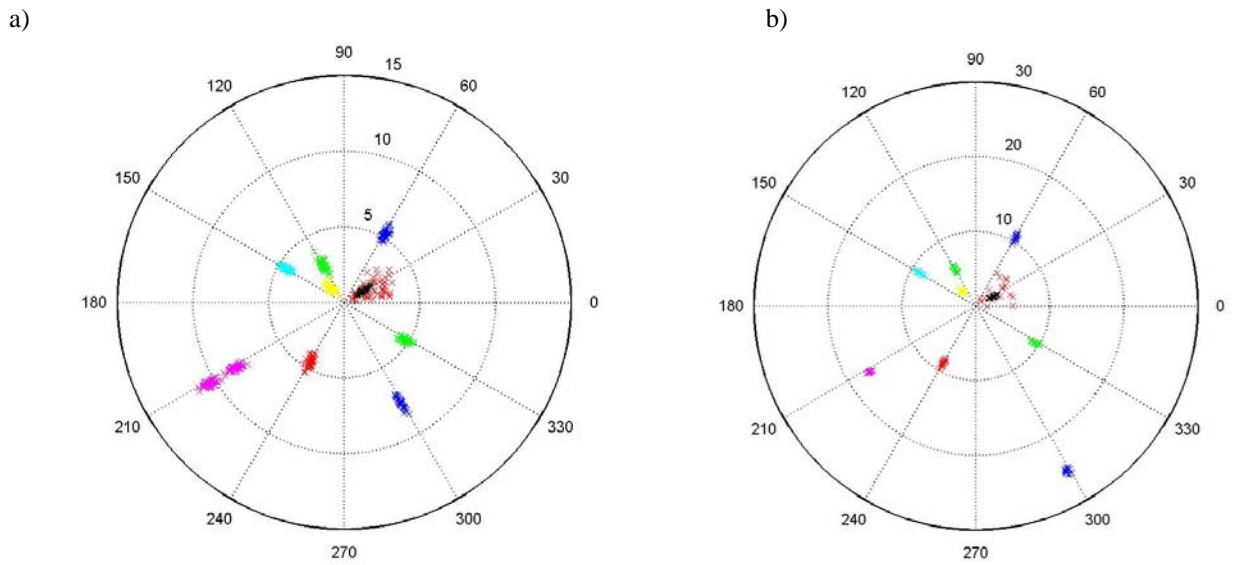

Fig.6 The computed bearings; a) time of listening 4s, b) time of listening 8s

The next illustrations show the images of the results of algorithm operation in a real system. The image in Figure 7 is the spectrogram of the bearing. The horizontal axis is the frequency, the vertical axis is the time. Constant vertical lines correspond to stable bearings. Figures 8 and 9 illustrate the results of measurements during real system operation. The signals are generated by different objects.

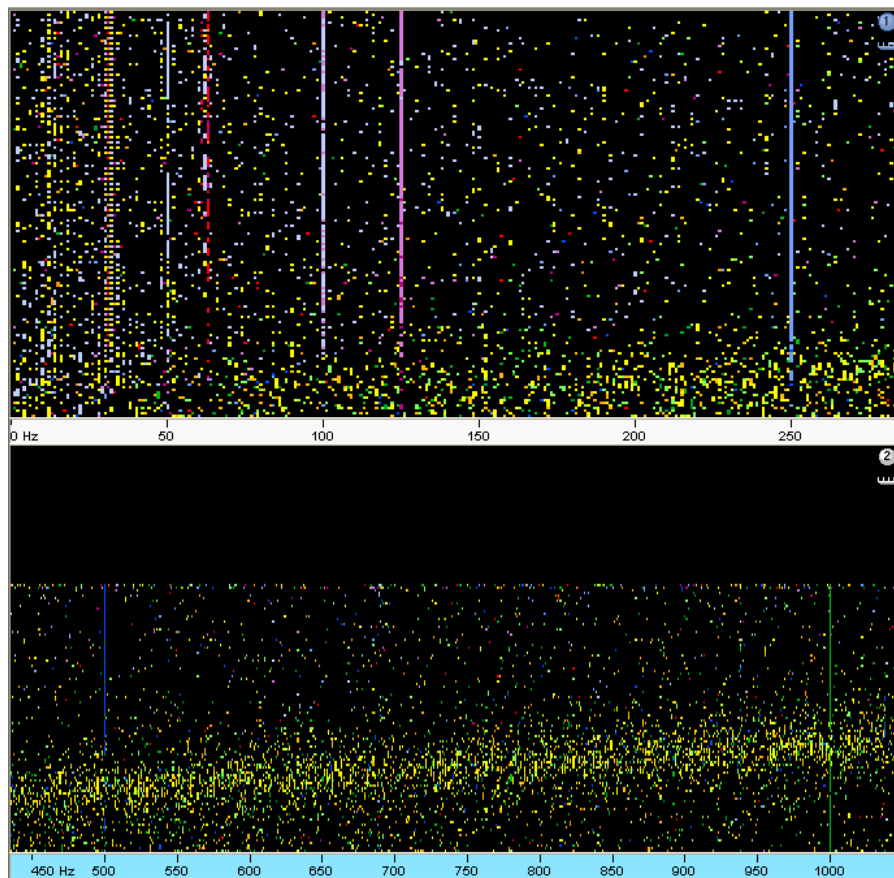

Fig.7 Image of the results of test signal measurements in a real system



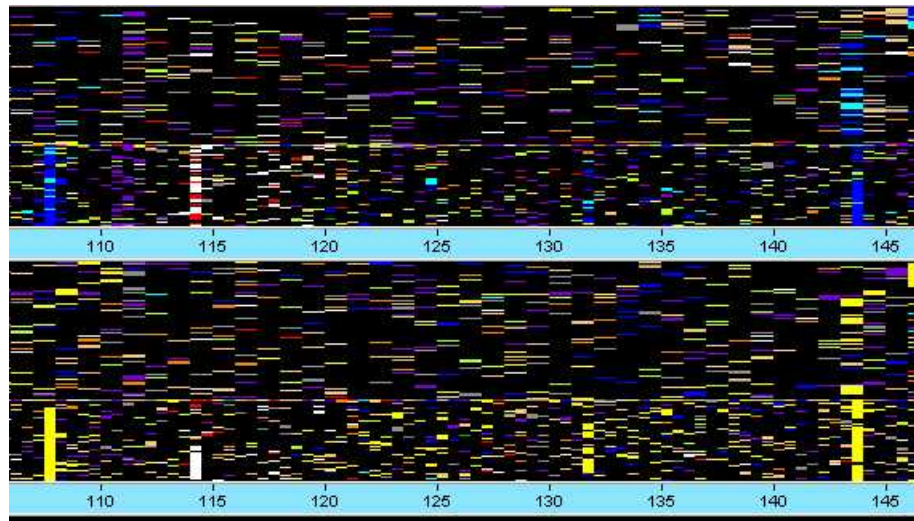

Fig.8 Bearings of real signals generated by the object – situation 1

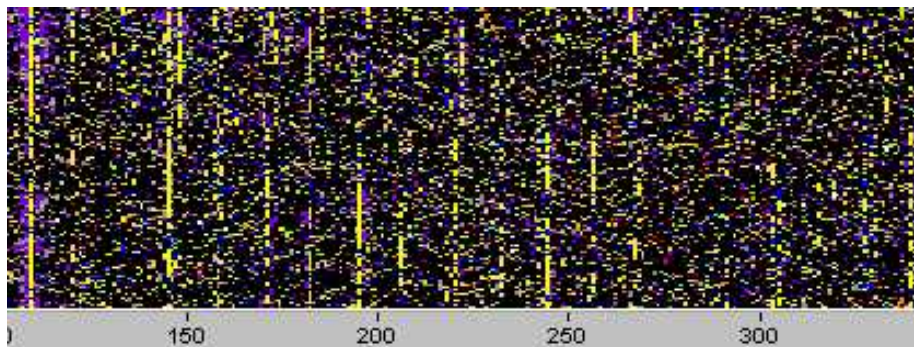

Fig.9 Bearings of real signals generated by the object – situation 2

## REFERENCES

- [1] R. Salamon: Directional Sonobuoy System for Detection of Submarines, SHA 2004.
- [2] R. Salamon, J. Marszal, M. Rudnicki: Underwater Acoustic System with Small Antenna for the Detection and Bearing of Sound Sources, 17th International Congress on Acoustics Proceedings, vol. II, Rome 2001.
- [3] R. Salamon, J. Marszal, A. Raganowicz, M. Rudnicki: Application of Fourier Transformation in a Passive Sonar with Gradient Hydrophones, Proc. of the Fifth European Conference on Underwater Acoustics. ECUA, Lyon 2000.
- [4] T. L. Stover: An Improved Arctangent Calculation Algorithm for DIFAR Bearing Computation in ASP, StormingMedia, 1982.
- [5] A. D. Delagrange: Further Improvements to a DIFAR Multiplexer-Demultiplexer System, StormingMedia, 1986.