

**Leszek Flis**  
**Akademia Marynarki Wojennej**

## **NUMERICAL SIMULATION OF BALISTIC IMPACT ON 10GHMBA STEEL ARMOR**

### **ABSTRACT**

A preliminary investigation of the ballistic impact on steel armor was carried out by resorting to numerical simulation using finite element method (FEM). The combined numerical and experimental study for analysis of 10GHMBA steel armor against 12,7 mm calibre bullet has been performed. The Johnson-Cook model was used for the steel plate. The bullet as an impactor was modeled as a rigid body. Numerical simulation was compared with experimental data to illustrate the performance of simulation [3, 11]. All FEM simulations were performed using ANSYS AUTODYN 12.1 code. The aim of the work is to find out how a rough computational model correlates with experimental ballistic testing. The numerical simulation is used to analyze ballistic impacts on the armors in order to obtain rough guidelines, particularly parameters adjustments for the further prototype configuration.

Keywords:

ballistic impact, steel armor, FEM, ANSYS AUTODYN.

### **INTRODUCTION**

The Institute of Machine Design in Faculty of Mechanical Engineering of the Polish Naval Academy conducts research projects [5, 8, 11] to develop the 10GHMBA steel hard armor.

As hard armors typically comprise of ceramic layers, metal and polymer, there are many design parameters involved in prototype constructions. Even if all materials are selected, geometrical factors such as size, thickness and arrangement are critical to performance.

The desing by trials and errors would require a lot of firing tests on prototypes, which are both time consuming and expensive. The numerical simulation provides an alternative approach for analyzing a ballistic impact, helps guiding the design process and reduces the number of the firing tests required to achieve the optimal configuration.

The present study aims to estimate a computational model that can qualitatively describe ballistic impact of the fast moving bullet onto 10GHMBA steel armor during firing test [11]. The efect of steel thickness are discussed in terms of deformation area.

In addition, as it is unable to obtain accurate material properties at such high strain rates due to the budget and procedure limitation, the results are not expected to be accurate but may point out certain characteristic of the problem. In short, this gives the nessesary knowledge to prepare the investigation to build a more complex numerical model.

## CASE STUDIES

The new 10GHMBA steel is high-strenght low-alloy steel grades with minimum yield stress 695.0 MPa. Steel was developed as a results of investigation carried out in the Polish Naval Academy. Advanced marine constructions, such as navy ships, tankers and offshoreplatforms require high-strenght low-alloy weldable steels for weight reduction. The 10GHMBA steel may be used for ships and offshore constructions and it is not susceptible to cold cracking during weldig [8].

Table 1. Mechanical properties of the 10GHMBA steel [3]

Young's modulus $E$ [MPa]	Density $\rho$ [g/cm <sup>3</sup> ]	Poisson's ratio $\nu$ [-]	Yeild stress $R_e$ [MPa]	Ultimate strength $R_m$ [MPa]
2,09·10 <sup>5</sup>	7,83	0,3	695,0	758,5

The experiments on steel plates are used as the case studies [3, 8, 11]. There were conducted at the certification firing range. A single 12,7 mm bullet was fired upon each specimen. In all, 11 armor specimens, each made up of an 10GHMBA steel plate are tested. The thicknesses of the these steel rings are from 8 to 36 mm

range, corresponding to the tested steel plate. The velocity range of the bullets  $V_{p_{ex}}$ , measured by the sensors before the bullets hit the target, from 724 to 813 m/s as summarized in table 2.

## NUMERICAL SIMULATION

All FEM simulations are performed using ANSYS AUTODYN 12.1 code [1] due to the nature of high speed and because the solve is one of not many which are dedicated to deal with such complicated problems.

A quarter model is used for the simulation of the bullet shape (fig. 1) penetrating a layer of steel material, as shown in figure 2a The bullet model corresponds to commercial bullets in terms of diameter and mass.

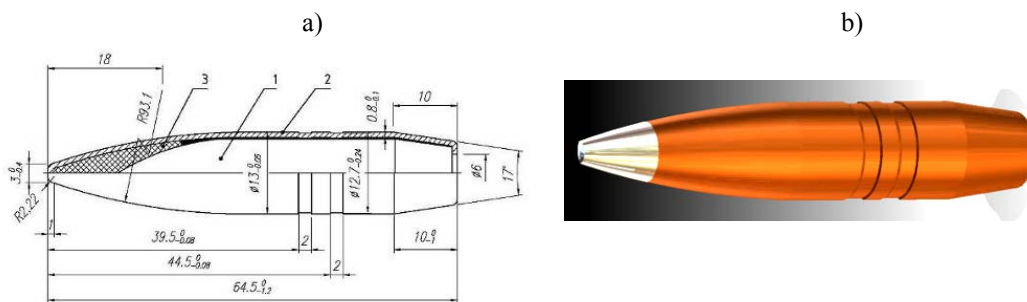

Fig. 1. The consider bullet:

a) main dimensions of 12,7 mm the bullet, b) and its CAD representation

Due to the anticipate severe deformation at contact, the fine mesh ( $1 \times 1 \text{ mm}^2$ ) is used at the steel region directly beneath the bullet tip while coarser mesh is used further away to reduce computational expense, as shown in figure 2b. The above model corresponds to 24185 nodes and 27239 elements. Elements are defined by eight nodes having the following degrees of freedom at each node: translations, velocities, and accelerations in the nodal  $x$ ,  $y$ , and  $z$  directions and this causes that the problem needs to be solved using a higher class computer. A personal computer is not enough to solve such a case. Sets in figure 2b) are considered as lagrang to lagrange environment copuling what poses a grat deal problems in the contact procedure.

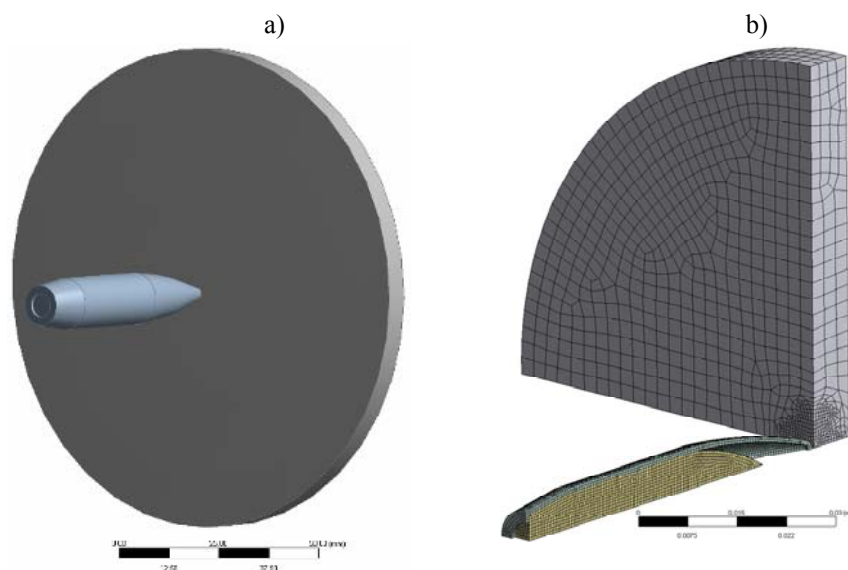

Fig. 2. The bullet/plate configuration and meshes

The fully restrained boundary condition is applied to the plane surfaces of sectioning. The bullet is given initial speed as a data measured from the sensors. The actual average bullet speed obtained from the firing test was of 769 m/s [11]. The modified density is used to obtain the bullet mass of 49,0 g used in the actual firing test.

During ballistic impacts between a bullet and an armor, the bullet tries to punch through the plate and may disintegrate in the process. The bullet is subjected to very large deformation and shattering of bullets upon impacts. This phenomenon involves many complex mechanisms, e.g. large deformation, crack and fracture, both of bullet and armor. Thus, it is extremely difficult to emulate these mechanisms in the simulation and it may be beyond a symulation software capability. In this case the impactor is very hard compared to the armor and due to bullets are modeled as a rigid body. The effect of the bullet deforming will be studied in the future.

The Johnson-Cook model is used for the steel plate as it is well suited to metal models that are subjected to high strain rate rate loadings [1]. The yield stress  $\sigma$  at non zero strain rate, depends on the strain hardening, strain rate hardening and temperature softening such that

$$\sigma = (A + B\varepsilon^n)[1 + C \ln(\dot{\varepsilon} / \dot{\varepsilon}_0)](1 - T_H^m), \quad (1)$$

where:

- $\varepsilon$  — effective plastic strain;
- $\dot{\varepsilon} / \dot{\varepsilon}_0$  — normalized effective plastic strain rate;
- $\dot{\varepsilon}$  — effective plastic strain rate;
- $\dot{\varepsilon}_0$  — reference strain rate equal  $1 \text{ s}^{-1}$ ;
- $T_H$  — nondimensional normalized (homologous) temperature  
 $(T - T_{room}) / (T_{melt} - T_{room})$ ;
- $A, B, C$  — material parameters ( $A$  initial yield stress,  $B$  hardening constant,  $C$  strain rate constant);
- $n, m$  — hardening exponent (work hardening coefficient) and thermal softening exponent.

The parameters values of the steel are adjusted from [1, 3, 7] such that  $A = 695 \text{ MPa}$ ,  $B = 510 \text{ MPa}$ ,  $C = 0,014 [-]$ ,  $n = 0,3$ ,  $m = 1,03$ . Shear modulus  $G = 8.03e7 \text{ kPa}$ , bulk modulus  $K = 1.74e8 \text{ kPa}$ , references temperature  $T = 300 \text{ K}$ , melting temperature  $T_{melt} = 1.793e3 \text{ K}$ .

The Johnson-Cook shear failure model (3) is based on the damage parameter  $\omega$  [1]. Failure occurs when the value of  $\omega$  exceeds 1.

$$\omega = \sum (\Delta\varepsilon / \Delta\varepsilon_f), \quad (2)$$

where:

- $\Delta\varepsilon$  — an increment of the equivalent plastic strain;
- $\varepsilon_f$  — strain at failure.

$$\varepsilon^f = (D_1 + D_2 \exp(D_3 p / q)) [1 + D_4 \ln(\dot{\varepsilon} / \dot{\varepsilon}_0)] (1 - D_5 T_H), \quad (3)$$

where:

- $p$  — is the pressure or mean stress;
- $q$  — is the Misses stress;
- $D_1$  to  $D_5$  — are failure parameters such that  $D_1 = 0.05$ ,  $D_2 = 3,44$ ,  $D_3 = -2.12$ ,  $D_4 = 0.002$ ,  $D_5 = 0.61$ , ref. rate = 1.0.

## RESULTS AND DISCUSSIONS

The result of the firing test and computer simulation are shown and compared in table 2. The bullet is allowed to penetrate the steel plate for 1–9 armor specimens. There were possibilities to carry out only the one shot to the one specimen. In the future it is obligatory to use bullets produced in the same period of time. In other case the specificity of the load material hurling makes too high differences between initial velocities. Cases for thickness 26, 28, 30 mm failed during the firing test and haven't been included in table 2.

Table 2. Case studies and main results

Lp.	Specimens thickness $h$ [mm]	Velocity before the bullet penetration $Vp_{ex}$ [m/s]	Velocity after the bullet penetration (firing test) $Vk_{ex}$ [m/s]	Velocity after the bullet penetration (simulation) $Vk_{sy}$ [m/s]	Puncture	
					Firing test	Simulat.
1	8	784	746	716	✓	✓
2	10	794	669	652	✓	✓
3	12	772	616	580	✓	✓
4	16	794	538	481	✓	✓
5	20	813	463	448	✓	✓
6	22	794	428	439	✓	✓
7	24	769	390	428	✓	✓
8	32	746	97	93	✓	✓
9	34	724	0	2	✗	✗
10	36	792	0	0	✗	✗

✗ — the bullet does not penetrate through the plate

✓ — the bullet penetrates through the plate

In the figure 3 there were compared experimental and simulation results from table 3 concerning the final velocity of the bullet as a function of the specimens thickness. It can be assumed that for the 10GHMBA steel specimen of 34 mm thickness there is a limit of the impact durability for the given bullet.

The main results, the ability of the plate to withstand impacts and prevent clean penetration are summarized in table 3. There are images of the plate puncture after impact shown together with simulation results. Table 3 shows the Von Mises

equivalent stresses contour plot for all cases at the end of penetration. The red color denotes areas in which the Misses stress exceeds flexural strenght. It can be noted that maximum values of the equivalent stresses are written down in the table 3 exceed the ultimate strength value for the 10GHMBA steel from table 1, given from a tensile test. Above results indicates that the computer model works as expected and identifies the strengthening of the material what is the result of the material work hardening while a high range strain rate is involved.

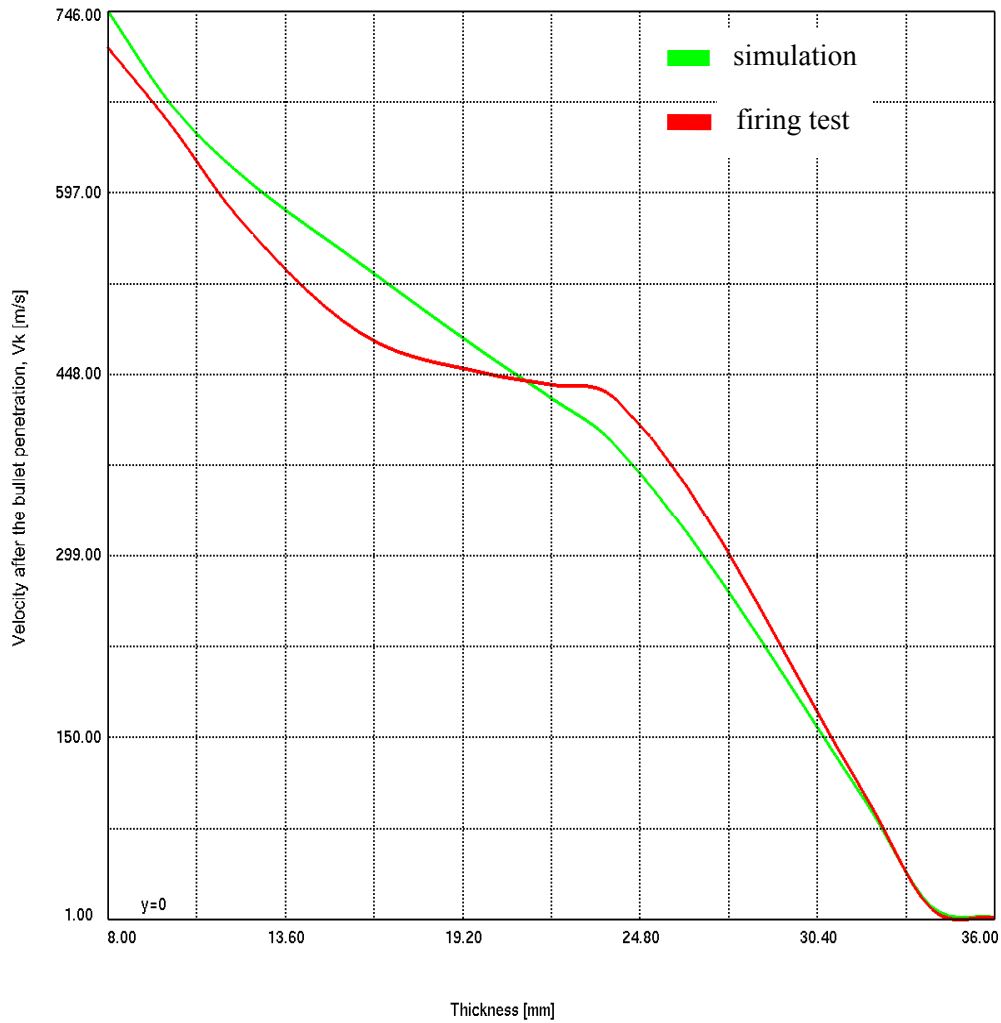

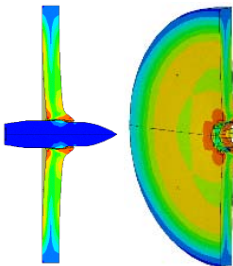

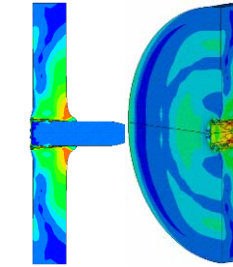

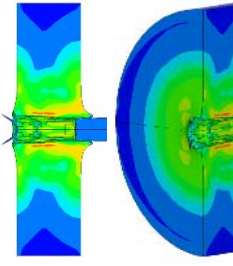

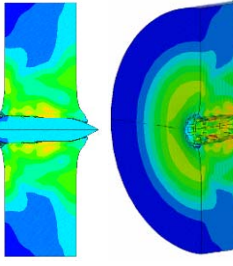

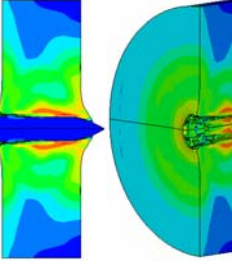

Fig. 3. Velocity of the bullet as a function of specimen thickness

Table 3. Selected comparison of the plate puncture after impact with simulation results as contour plots of the Von Mises equivalent stresses

<p><math>h = 8 \text{ mm}</math></p> <p><math>Vp_{ex} = 784 \text{ m/s}</math>  <math>Vk_{ex} = 746 \text{ m/s}</math>  <math>Vk_{sy} = 716 \text{ m/s}</math>  <math>\sigma_{max} = 1137 \text{ MPa}</math></p>	 	
<p><math>h = 16 \text{ mm}</math></p> <p><math>Vp_{ex} = 794 \text{ m/s}</math>  <math>Vk_{ex} = 538 \text{ m/s}</math>  <math>Vk_{sy} = 481 \text{ m/s}</math>  <math>\sigma_{max} = 1278 \text{ MPa}</math></p>	 	
<p><math>h = 32 \text{ mm}</math></p> <p><math>Vp_{ex} = 746 \text{ m/s}</math>  <math>Vk_{ex} = 97 \text{ m/s}</math>  <math>Vk_{sy} = 93 \text{ m/s}</math>  <math>\sigma_{max} = 1112 \text{ MPa}</math></p>	 	
<p><math>h = 34 \text{ mm}</math></p> <p><math>Vp_{ex} = 724 \text{ m/s}</math>  <math>Vk_{ex} = 0.0 \text{ m/s}</math>  <math>Vk_{sy} = 2.0 \text{ m/s}</math>  <math>\sigma_{max} = 1122 \text{ MPa}</math></p>	 	
<p><math>h = 36 \text{ mm}</math></p> <p><math>Vp_{ex} = 792 \text{ m/s}</math>  <math>Vk_{ex} = 0.0 \text{ m/s}</math>  <math>Vk_{sy} = 0.0 \text{ m/s}</math>  <math>\sigma_{max} = 1048 \text{ MPa}</math></p>	 	



## CONCLUSION

The pragmatic model, employing only heightened tensile strength of steel, enables the results to qualitatively agree with the experimental observation. The computational model was consistent with the experimental results from the firing test. Further refinement of the current model is warranted for quantitative predictability.

## REFERENCES

- [1] AUTODYN®Explicit Software for Nonlinear Dynamic, *Theory Manual Revision 4.3*, Century Dynamics, 2005.
- [2] Borvik T., *Numerical simulation of plugging failure in ballistic penetration*, 'International Journal of Solids and Structures', Vol. 38, pp. 6241–6262.
- [3] Cwiek J., Labanowski J., *The research on usability of 14HNMBCu and 10GHMBA high-strength low-alloy steels for marine applications*, 'Transactions on the Built Environment', Vol. 11, WIT Press, 1995.
- [4] Dobrociński S., *Stabilność rozwiązań zagadnień odporności uderowej konstrukcji*, ITE, Akademia Marynarki Wojennej, Gdynia 2000.
- [5] Fila J., *Badania odporności balistycznej materiałów okrętowych*, raport Nr 1/1993/IPBMO/POWŁ, Z1.KBN/AMW, cz. 1, 1993.
- [6] Jach K., *Komputerowe modelowanie dynamicznych oddziaływań ciał metodą punktów swobodnych*, PWN, Warszawa 2005.
- [7] Johnson & Cook, *LA-4167-MS Selected Hugoniot EOS*, 7<sup>th</sup> Int. Symp. Ballistics, 1969.
- [8] Kyzioł L., *Charakterystyki dynamiczne materiałów na konstrukcje morskie*, praca badawcza pk. „KONSTRUKTOR”, III etap — 2004, Biblioteka Główna AMW, ss. 49.
- [9] Meyers M. A., *Dynamic behaviour of materials*, A Wiley-Interscience Publication, 1994.
- [10] Potter D., *Metody obliczeniowe fizyki*, PWN, Warszawa 1977.
- [11] Szturomski B., *Charakterystyki dynamiczne do symulacji numerycznej materiałów stosowanych na osłony antyterrorystyczne na jednostkach pływających*, praca badawcza, AMW, Gdynia 2009.

- [12] Tarin V., *Numerical Simulation of Ballistic Impact on Ceramic Armor*, Department of Mechanical Engineering, Chulalongkorn University, Bangkok, 10330, 2005.
- [13] Tarin V., *Numerical Simulation of Level 3A Ballistic Impact on Ceramic/Steel Armor*, The 20<sup>th</sup> Conference of Mechanical Engineering Network of Thailand, 1820, October 2006.
- [14] Zukas J., *Introduction to hydrocodes*, Elsevier, 2004.

## **SYMULACJA NUMERYCZNA UDARU BALISTYCZNEGO W PANCERZ ZE STALI 10GHMBA**

### **STRESZCZENIE**

Wstępne badania udaru balistycznego w pancierz stalowy zostały wykonane metodą elementów skończonych (FEM) z zastosowaniem symulacji numerycznej. Przeprowadzono łączone numeryczne i eksperymentalne badania wytrzymałości pancierza ze stali 10GHMBA na uderzenie pocisku kalibru 12,7 mm. W przypadku płyty stalowej wykorzystano model Johnson-Cook. Pocisk (element uderzeniowy) został uformowany jako ciało sztywne. Symulację numeryczną porównano z danymi eksperymentalnymi w celu zilustrowania działania symulacji. Wszystkie symulacje FEM zostały wykonane z zastosowaniem kodu ANSYS AUTODYN 12.1. W artykule zaprezentowano, jak model obliczeniowy koreluje się z eksperymentalnymi testami balistycznymi. Symulacja numeryczna jest wykorzystywana do analizy oddziaływania balistycznego na pancierze dla uzyskania wstępnych wskazówek, głównie parametrów dostosowania w dalszym konfigurowaniu prototypu.

#### Słowa kluczowe:

uderzenie balistyczne, pancierz stalowy, FEM, ANSYS AUTODYN.

Recenzent prof. dr hab. inż. Tadeusz Niezgoda