

Waterjet propulsion of small-draught inland waterways ships

Zygfryd Domachowski, Prof.
Wiesław Próchnicki, Assoc. Prof., D.Sc.
Gdańsk University of Technology

ABSTRACT

This paper presents some aspects of ship waterjet propulsion. Advantages and limitations of its applicability are discussed. Also, possible use of waterjet propeller to move a small-draught inland waterways ship, is considered.

Keywords : ship propulsion, hydromechanics

GENERAL CHARACTERISTICS OF SHIP WATERJET PROPULSION

Waterjet propulsion of ship is based on application of 3rd principle of Newton's dynamics : „If two bodies mutually interact, their interaction forces are equal to each other and pointing in opposite directions”. In the waterjet propulsion a crucial role is played by a pump. Located nearby ship's stern, it takes in water through a recess in ship's bottom. From outlet of the pump the water is directed under high pressure to a nozzle placed in the ship's stern. The force pushing out the water from the stern is equal – as to its value – to the force moving the ship in the opposite direction. As to rotate the nozzle is possible practically by an arbitrary angle the same ship propulsion force can be obtained at any arbitrary position of the nozzle. The ship propulsion force depends on water flow rate at the nozzle outlet.

The pump is driven – through the shaft – by a diesel engine (in most applications which have been realized so far) or a gas turbine. The waterjet propulsion may even be of a higher energy efficiency as compared with that of the conventional propulsion (screw propeller), however only in the case if the nozzle, pump and driving engine are properly selected.

The steering of waterjet-propelled ship (change of direction of its motion) is effected by an appropriate change of outlet nozzle position. Astern motion is ensured by application of a deflector with the use of which the change of sense of ship propulsion force can be obtained. In general, the waterjet propulsion is considered favourable at the ship speed exceeding 25 knots. However, a correctly designed waterjet propulsion may be competitive against conventional one also at much smaller speeds. The waterjet propulsion extends its application to the recreation ships and sea-going coastal ships of special use. As compared with conventional one the waterjet propulsion has many advantages which are discussed below.

EXAMPLES OF WATERJET PROPULSION APPLICATIONS MADE SO FAR

Attempts to apply waterjet propulsion to ships have appeared as early as in the ancient ages.* However the Hamilton's low-power waterjets (1954) intended for propulsion of fast river boats can be considered as the first developed construction.**

Nowadays many firms build waterjets of a wide range output: from a few hundred kW to a few dozen MW.

Rolls-Royce company, a leader of modern waterjet constructions, offers complete propulsion systems for very fast ferry ships, cargo vessels, warships, cruise ships and yachts. Up to now about 1400 assemblies of the output from 22.000 kW to 70.800 kW have been built. And, a ship propulsion system of 250 MW output is under development

Due to the advantages of waterjet propulsion, its application range has become wider and wider. The most important of them are : good manoeuvrability of ship, environmental safety, comfort for passengers. Out of the ship waterjet propulsion applications made so far the following are worth mentioning :

- ☆ In the navy – it serves for propelling the patrol crafts, torpedo boats, destroyers, frigates and cruisers, first of all in USA, but also in France, Italy, Norway, Australia, Spain, Thailand, Canada, Japan, Republic of South Africa and Germany
- ☆ In the passenger fleet – it serves for propelling small inland waterways ships, fast yachts, recreation ships, including fishing ones
- ☆ In the merchant fleet – it has so far had rather narrow application, first of all for propelling fast ferries.

ADVANTAGES OF WATERJET PROPULSION

The waterjet propulsion – as far as its application to recreation passenger ships is concerned – shows many important advantages.

Safety

In contrast to the screw propeller drive the waterjet propulsion is not endangered by floating solid fragments, ropes or fishing nets. In particular, the waterjet propulsion **correctly fulfils** its role in shallow waters (like in the considered case of its application to an inland waterways ship). Also, persons remaining in water : swimmers, water skiers, divers etc are not exposed to hazards from the side of such device. Any overload of main engine is excluded as its power demand maintains constant regardless of developed ship speed.

* Archimedes axial water pump (287-212 AChN), Leonardo da Vinci pump (1452-1519), Toogwood's & Hayese's patent (1661), Benjamin Franklin's pulsators (1706-1790).

** So-called „First Hamiltonians”.

Manoeuvrability

Even at a low speed of motion the waterjet- propelled ships maintain excellent manoeuvrability due to possible setting an arbitrary spatial position of the outlet nozzle. Thrust force of an arbitrary value and arbitrary direction can be applied to ship . It is especially useful on narrow waterways (like in the considered case). In no circumstances any help from the side of any other floating unit is necessary. Even in rough weather conditions (strong wind, high waves) ship motion control is possible.

Energy efficiency

The waterjet propulsion correctly adjusted to the driving engine and ship hull, makes engine work at optimum settings possible, i.e. when the specific fuel oil consumption is the lowest. It concerns all its operational phases : moving, starting, stopping and standing-by. Moreover, maintenance cost of such installation are low; it means that operational costs of such propulsion system are low.

Travelling comfort of passengers

As compared with the screw propeller drive the waterjet propulsion ensures lower noise and vibration level on board of ship. In particular, no cavitation noise from the side of screw propeller is emitted . Screw propellers being of a lower rotational speed than that of rotating elements of waterjet propulsion system, are more bothersome. Pumps are placed in properly insulated casings.

Refloating the grounded ship

Motion of an inland waterways ship in shallow waters is considered. In the case of grounding the waterjet-propelled ship is able to refloat without any help but only by using its reverse propulsion which can develop a high thrust value.

On standing-by ship or during manoeuvres waterjet thrust reaches its maximum value expressed by the formula :

$$F_{u_{max}} = m \cdot (w_2 - u)_{u=0} = m \cdot w_2 \quad (1)$$

where :

- m – water mass flow rate of waterjet [kg/s]
- w₂ – out- of- the- nozzle flow velocity
- u – ship speed.

In the rated working point of waterjet the following relation is satisfied :

$$w_{2_{nom}} = \frac{u_{nom}}{\left(\frac{u}{w_2}\right)_{nom}} \quad (2)$$

where :

$$\left(\frac{u}{w_2}\right)_{nom} \cong 0.8 \div 0.85$$

hence :

$$\frac{F_{u_{max}}}{F_{u_{nom}}} \sim \frac{1}{1 - \left(\frac{u}{w_2}\right)_{nom}} \cong 5 \div 7 \quad (3)$$

It means that on the standing-by ship a propulsion force several times greater than that nominal can be achieved. It is a greatly favourable feature of such propulsion system as in the case of ship grounding it enables to cause an effective motion of ship hull, unavailable by means of any other propulsion system.

Impact on the environment

The waterjet propelled ships generate much lower water-borne disturbances (noise) as compared with the screw-propelled ones. It is specially important for the water natural environment because of much lower hazard to flora and fauna.

At a properly designed inlet to diffuser (based on model test results) can be obtained laminar inflow, lack of flow separation and turbulence (Fig.1). This way only small losses at inlet to diffuser are produced. The following relation is fulfilled with a good accuracy :

$$w_1 \cong u \quad (4)$$

where :

u – ship speed

w₁ – water velocity at inlet to diffuser.

Furthermore the vertical component velocity of the water flowing into the diffuser (Fig. 1) :

$$w_H = w_1 \cdot \sin \alpha = u \tan \alpha \quad (5)$$

decides on the force imposed on the waterway bed (scouring force); in the case of shallow water it is of a very small value and amounts to about 5÷10% of the water inflow velocity w₁. Therefore it can be stated that erosion impact of waterjet propeller on the bed of shallow water is not greater than that of conventional screw propellers.

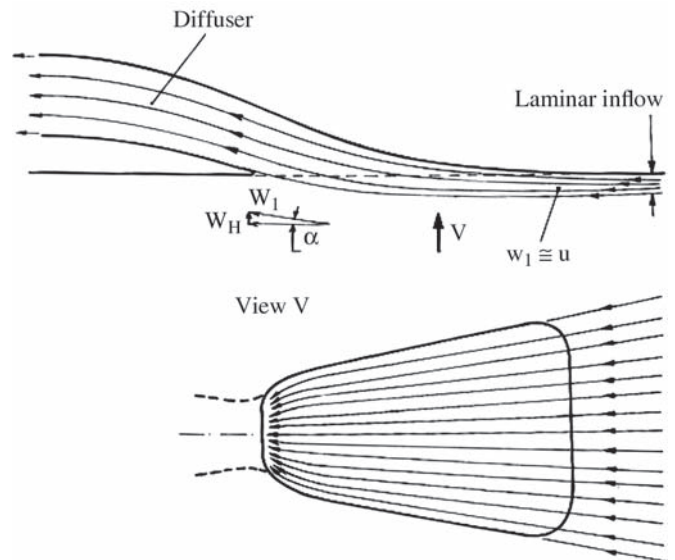

Fig. 1. Laminar water flow into diffuser .

Simplicity of construction

The waterjet propeller is characterized by a high simplicity of construction. It consists of a flow passage (diffuser and confuser), rotary pump (diagonal, helicoidal or impeller one) and a deflector which makes flow reversing and ship rotating possible.

Such propellers are produced as complete units by such firms as Hamilton Waterjet, Castoldijet, Ka-Me-Wa, Lips, Graupner etc.

To drive the waterjet propeller rotary pump a diesel engine or gas turbine is used. In Fig. 2 the ship fitted with the waterjet propeller of Ka-Me-Wa, driven by the Rolls-Royce gas turbine, is presented.

Owing to the above mentioned advantages the waterjet propulsion constitutes an alternative for the screw propeller drive in some, but not all, applications. It may only supplement but not

substitute the crew propeller drive. As usually the proper way is to choose one of the two kinds of ship propulsion system by selecting that suitable for a given ship's type and function.

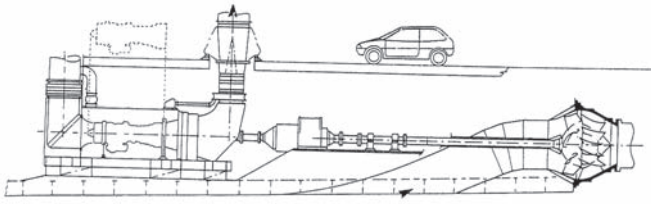

Fig. 2. The waterjet propeller driven by the gas turbine

LIMITATIONS IN APPLICATION OF WATERJET PROPELLER

An important design problem of waterjet propeller is strong dependence of the nozzle outlet area A_2 on the ship speed u .

$$A_2 = \left(\frac{N_u}{1 - \bar{u}} \right) \cdot \frac{1}{\bar{u}^2 \cdot \rho_w \cdot z} \quad (6)$$

where :

N_u – propulsion power

$\bar{u} = \frac{u}{w_2}$ – velocity index

ρ_w – water density

z – number of outlet nozzles.

At given values of N_u and \bar{u} the decreasing of the velocity u by 10% makes the outlet nozzle area A_2 increasing by 37%; at 20% decrease of u the outlet nozzle area increases almost twofold, and the velocity decrease by 30% results in the outlet nozzle area A_2 almost three times greater.

Taking into consideration the relationship :

$$N_u = \alpha \cdot u^3 \quad (7)$$

where :

α – coefficient of ship resistance power, one can obtain the following area of a single nozzle :

$$A_2 = \left(\frac{1}{1 - \bar{u}} \right) \cdot \alpha \quad (8)$$

The ship resistance power coefficient α is defined as a function of the ship mass displacement D_w (expressed in tons) and the Admiralty coefficient C_0 :

$$\alpha \left[\frac{\text{kW}}{\text{m}^3/\text{s}^3} \right] \cong 5.40 \frac{\sqrt[3]{D_w^2}}{C_0} \left[\frac{\text{KM}}{\text{knot}^3} \right] \quad (9)$$

In Fig.3 the $A_2 - \alpha$ relationship is presented for the selected values of the velocity index $\bar{u} = 0.6; 0.7; 0.8$ and 0.9 , and the assumed number of outlet nozzles $z = 2$.

And, as shown in Fig. 4 the smaller ship speed the greater hydraulic losses. The coefficient of total hydraulic losses has been defined as follows [10] :

$$\sum_{i=1}^h \zeta_i = 2 \frac{N_L + N_H}{\mu u^2} \quad (10)$$

where :

N_L – power of hydraulic losses in flow passage of waterjet propeller

N_H – power of elevating the water stream which flows out of the nozzle, up to the level H (H is the height of nozzle axis over the water level).

Hence it can be stated that the waterjet propeller is well adjusted to propelling fast ships.

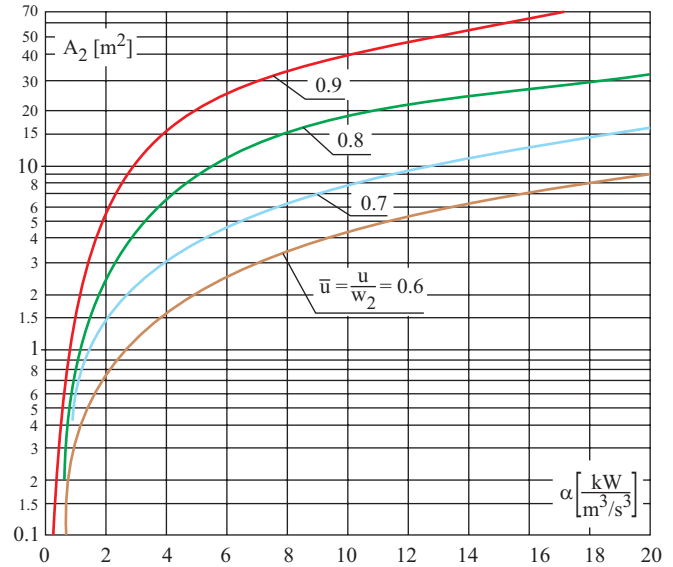

Fig. 3. The outlet area of two-nozzle waterjet propeller, A_2 , in function of the ship resistance power coefficient α and the velocity index \bar{u} .

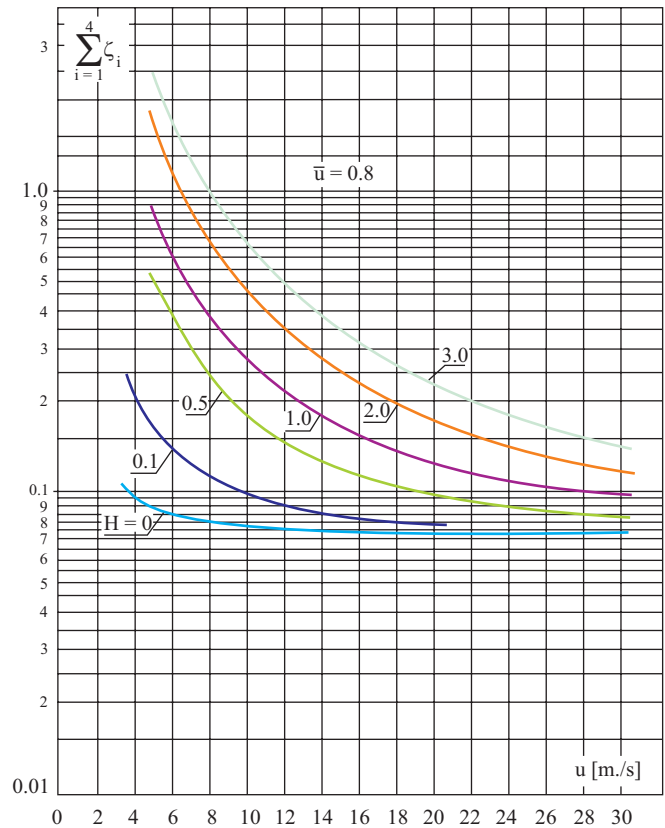

Fig. 4. Diagram of total energy losses in flow passage of waterjet propeller.

SPECIFIC REQUIREMENTS FOR WATERJET PROPULSION OF SMALL-DRAUGHT INLAND WATERWAYS SHIPS

The propulsion system of the two-segment recreation passenger ship intended for inland waterways service, is here considered. Such application requires to take into account a few specific conditions. The following belong to them :

- ❖ limited width of waterway (limited width of locks)
- ❖ limited depth of waterway (a small draught of ship is demanded)
- ❖ possible events of ship grounding on shallows
- ❖ environmental protection requirements
- ❖ ensuring a necessary travelling comfort for passengers
- ❖ limited ship speed.

Possible application of waterjet propulsion should be analyzed with taking into account a.o. the above mentioned aspects :

- As far as the aspect of limited waterway width is concerned, the waterjet propulsion makes it possible to precisely control ship motion at an arbitrary speed. Ship steering at a very low speed („zero speed”) facilitates berthing the ship as well as keeping it stopped short. The waterjet propulsion ensures also precise steering the ship during its moving astern.
- In the waterjet propulsion there are no elements protruding below the hull bottom . This way, ship sailing in very shallow waters is possible. Water-outlet area and ship's bottom surface are matched up. Nozzle's outlet can be located over water level. The more shallow water the lower efficiency of ship screw propeller. It does not concern the waterjet propeller.
- If waterjet-propelled ship grounds its refloating is facilitated by two circumstances : firstly, such ships usually have no elements protruding below hull bottom surface, secondly, waterjet propulsion ensures large value of thrust in moving astern. It is also important that in those conditions to cause a failure to waterjet propeller by carried - away sand and gravel is much less probable as compared with the case of screw propeller.
- Waterjet- propelled ships are much less hazardous to the environment than screw-propelled ones. It concerns possible mechanical failures of living organisms (fauna and flora), as well as waterborne noise.
- Passengers onboard waterjet- propelled ship enjoy a higher travelling comfort as compared with that on screw-propelled ship. As thrust force is directly transferred from waterjet propeller to hull, without help of any shafting and screw propellers the engine and pump can be seated on an elastic foundation, that reduces hull vibrations generated by propulsion system. There are neither hull vibrations due to transmission shafting and screw propellers nor cavitation noise effected from the side of screw propellers. In waterjet propulsion system, engine shaft's rotational speed is much greater than that in screw propeller drive system. Moreover the whole propulsion system is secured by a tight casing to lower effects of noise emitted to environment.
- As assessed, the waterjet propulsion system is most efficient at ship's operational speed in the range from 20 to 40 knots. And, at a given ship speed the screw-propeller drive system is a little more efficient than the waterjet propulsion. However the difference is balanced by a little higher ship hull efficiency (due to a lower hull resistance to motion), resulting from lack of screw propellers, shafts, rudders and shaft brackets located outside the hull. As a matter of fact the influence of the above mentioned elements on hull resistance to motion decreases along with ship speed decreasing.

Application of waterjet propulsion to large fast floating units is wider and wider. And, to decrease ship resistance to motion special hull forms are applied such as : catamarans, slender hulls (of a large L/B ratio) fitted with side sponsons to improve ship's stability. Worth mentioning, the waterjet propulsion makes it

possible to fully make use of driving power at any ship speed value, a very small too.

SPECIFIC FEATURES OF SHIP WATERJET PROPULSION

- ⇒ Application of high-speed diesel engine or gas turbine as a waterjet driving motor requires a transmission gear to be installed between the engine and pump.
- ⇒ Choice of a waterjet propeller depends a.o. on ship's hull form, on one side, and on the other side, in designing the ship hull form the specificity of such kind of propulsion should be taken into account.
- ⇒ In selecting the waterjet propulsion an important role is played by the ratio of propulsion power to weight of power plant.
- ⇒ A driving engine and propeller itself should be so selected for a given ship speed as to eliminate phenomenon of cavitation.
- ⇒ As ship propulsion thrust force does not affect the driving engine (through shafting and transmission gear) the shaftline can be inclined by a small angle to make alignment of shaft and waterjet propeller, easier. The maximum values of shaft slope angle depend on shaft's rotational speed and are equal from about 3° at 5000 rpm to about 8° at 2000 rpm.
- ⇒ The underwater exhaust gas pipe has not to be located before the water inlet to propeller so as to avoid gas sucking -in to the pump, which could result in lowering the propulsion thrust force. It should be placed aft the water inlet.
- ⇒ The fuel oil tank should be placed in longitudinal position close to ship's centre of gravity so as to avoid ship's trim disturbing as a result of fuel consumption or refuelling operations.
- ⇒ The driving engine and electric generator (if a shaft generator is provided for) should be placed close to ship's centre of gravity. For this reason they should be installed, if possible, on guides to facilitate ship balance correction after trials.
- ⇒ In ship design calculations an additional weight of the water contained in the propeller should be taken into account. Application of gas turbine to waterjet propulsion for small-draught inland waterways ship

The output power of waterjet propellers is contained in the range of 75 ÷ 900 kW. Like in the ship screw- propeller propulsion, also in the waterjet propulsion the application of high-speed diesel engines prevails. Gas turbines are also used however their share is lower.

Gas turbines – in a simple arrangement – are of a lower thermodynamic efficiency as compared with that of piston engines (in some cases regeneration is applied to improve the efficiency of gas turbines). Whereas it seems that other features of gas turbine could prevail in the considered application of waterjet propulsion to the passenger inland waterways ship in question.

In the above mentioned application the following features of gas turbine should be considered favourable :

- low sulphur content in exhaust gas (exhaust gas cleaning devices - unnecessary)
- low level of bending and torsional vibrations and noise (passenger cabins can be located close to propeller)
- low cost of maintenance, overhauls and lubricating oil
- high serviceability (high reliability, and possible fast repair or replacement of engine)
- small dimensions.

The features predestine gas turbine for propelling the passenger inland waterways ship in question. Therefore in the

preliminary concept of waterjet propulsion system for the ship a gas turbine was chosen to drive the pump, an element of the waterjet propeller.

SUGGESTIONS AS TO POSSIBLE APPLICATION OF WATERJET PROPELLER TO MOVE THE PASSENGER SHIP INTENDED FOR BERLIN – KALININGRAD ROUTE

- ★ a waterjet propeller, selected out of the units available on the market (produced e.g. by Castoldijet or Hamilton Waterjet), should be adjusted to the assumed nominal velocity $u = 4,166... \text{ m/s}$, by matching - up its nozzle outlet area to the required A_2 value and output power
- ★ if to apply – instead of the proposed gas turbine – a diesel engine, to obtain total efficiency more than two times greater will be possible. Similarly, if to assume that the centre of outlet nozzle is not placed over water level, i.e. $H = 0$, the total efficiency will increase by $\sim 13\%$
- ★ in Fig.5 and 6, on the basis of Casteldijet’s offer drawings, are presented the gas- turbine-driven propulsion devices arranged in ship’s engine room.

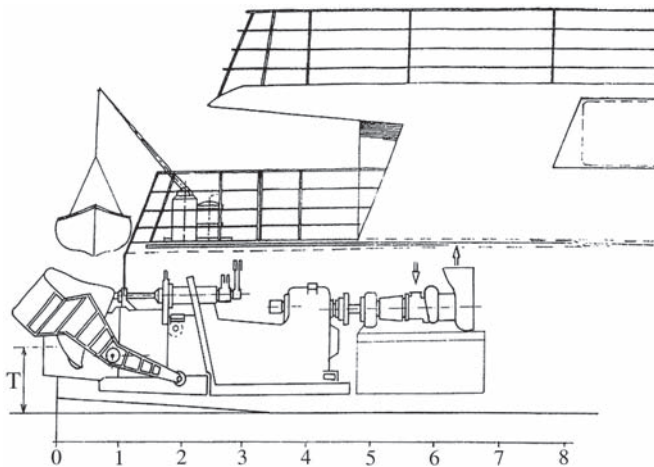

Fig. 5. Arrangement of the waterjet propeller in ship's engine room – side view .

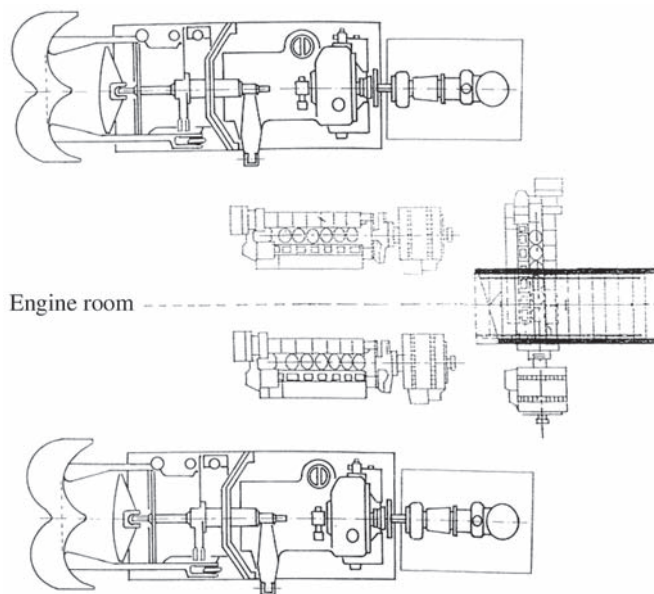

Fig. 6. Arrangement of the waterjet propeller in ship's engine room – downward view .

FINAL REMARKS

Summing up, the following aspects of the ship waterjet propulsion system are worth attention paying :

- The waterjet propulsion system is of important advantages as compared with the conventional screw - propeller propulsion system :
 - Lack of any movable elements behind the hull
 - Much lower hull-propeller interaction resulting in the hull efficiency increase by $13 \div 19\%$
 - Favourable energy indices at partial load
 - Lower torsional vibrations
 - Easy execution of turns and astern moving
 - Possible elimination of need of blade rudder (which results in lowering hull resistance to motion).
- Losses in flow passage are inversely proportional to u^2 and monotonically increasing along with the ship speed u increasing (Fig.4). The losses depend only slightly on the velocity index \bar{u} . Moreover they depend on smoothness of flow passage, hence its high smoothness should be ensured.
- Large dimensions of flow passage constitute an important design problem of waterjet propulsion. The circular cross-section area of its outlet, A_2 , is proportional according to some expression as follows :

$$A_2 \sim \alpha \left(\frac{\bar{u}^2}{1 - \bar{u}} \right)$$

where :

- α – acc. (15) – coefficient of hull resistance to motion
- $\frac{1 - \bar{u}^2}{\bar{u}}$ – the expression proportionally associated with the efficiency : i.e. the greater the assumed efficiency the greater the required dimensions of outlet nozzle (and flow passage).

- Reliable performance of waterjet propeller is ensured by :
 - protection of its pump and flow passage against hard solid fragments,
 - better control of turning and astern moving,
 - modernization of load - carrying bearing installed inside the pump, e.g. by applying a bearing fitted with water-lubricated ceramic sleeves.

The small-draught inland waterways ship in question has to operate with a low speed. It affects its propulsion efficiency. The ship is slender - hence its flow passage dimensions are restricted, which as a result limits waterjet propulsion efficiency.

NOMENCLATURE

- A_2 – cross-section area of outlet nozzle [m^2]
- F_u – thrust force [N]
- m – rate of water mass flow through propeller [kg/s]
- u – ship speed [m/s]
- w_1, w_2, w_H – water velocity of inflow to diffuser, outflow from confuser, and vertical component of velocity of water inflow to propeller, respectively [m/s]
- \bar{u} – propeller velocity index [-]
- α – coefficient of ship hull resistance power [$\text{kW}/(\text{m/s})^3$]
- ρ_w – water density [kg/m^3]
- ζ_{st} – dimensionless coefficient of hydraulic losses and those for water stream elevation [-].

BIBLIOGRAPHY

1. Allison J.: *Waterjet Selection and Performance at Model and Full-Scale for the Advanced Material Transporter (AMT)*, for U.S. Navy, 1991
2. Blount D.L., Grossi L., Lauro G.: *Sea Trials and Model Ship Correlation Analysis of the High Speed Gas Turbine Vessel „Destriero”*. FAST'91, Trondheim. June, 1991
3. Centkowski J.: *Research & design problems of waterjet propellers* (in Polish). 3rd Symposium of Ship Hydromechanics. Gdańsk, 1975
4. Domachowski Z., Próchnicki W.: *Advantages of Waterjet Ship Propulsion in Inland Waterway Transport*. Proc. of 3rd International Conference on Maritime Transport. Maritime and Inland Waterway Transport and Maritime History, Barcelona, May, 2006
5. Forde M., et al.: *Computational Fluid Dynamics Applied to High Speed Craft with Special Attention to Water Intake for Waterjets*. FAST'91, Trondheim. June, 1991
6. Lewis J.W.: *Calm Water Performance Trials on the 160 ft SES-200 with Diesel Driven Waterjets*. NSCSES Report No. 60-248, June, 1991
7. Łazarkiewicz S., Troskoleński A.: *Impeller pumps* (in Polish). Scientific Technical Publishing House (WNT). Warszawa, 1968
8. Mavlyudov M.A.: *Waterjets of Dynamically-Supported Ships (DSS) – Some Problems and Methods of Solution*. Krylov Shipbuilding Research Institute, St.Petersburg, Russian Federation, Personal Communication. June, 1993
9. Mununga L., Huntsman I.: *Water intertake flow improvement using boundary layer blowing and vortex generators*. IPENZ Transactions, 1999, vol.26, No.1/EMCh.
10. Próchnicki W.: *A proposal of ship gas-turbine driven waterjet propulsion – preliminary considerations*. Polish Maritime Research, S, 2004
11. Stricker J.G., Becnel A.J., Purnell J.G.: *Advanced Waterjet Systems*. ASNE Small Boats Symposium. May, 1993
12. Svensson R.: *A Description of the Waterjets Selected for „Destriero”*. FAST'91, Trondheim, June, 1991
13. Troskoleński A.T.: *Hydromechanics* (in Polish). Scientific Technical Publishing House (WNT). Warszawa, 1969
14. Van Terwisga T.: *On the Prediction of the Powering Characteristics of Hull-Waterjet Systems*. Marin Jubilee, Wageningen, May, 1992
15. Naval Architecture, November, 2001

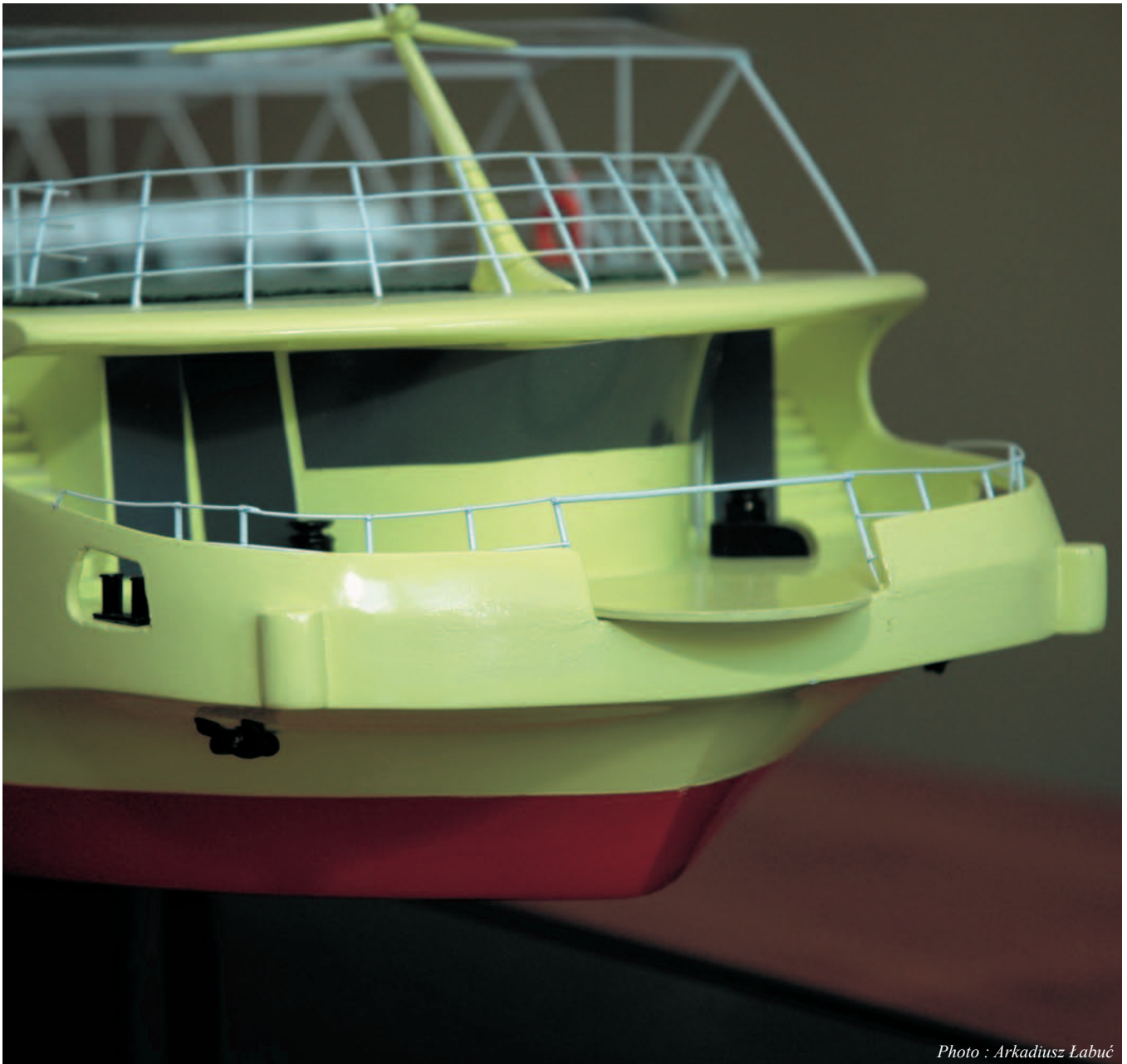

Photo : Arkadiusz Łabuć