

## APPLICATION OF ACTIVE MAGNETIC BEARINGS FOR IDENTIFICATION OF THE FORCE GENERATED IN THE LABIRYNTH SEAL

DOROTA KOZANECKA  
ZBIGNIEW KOZANECKI  
TOMASZ LECH  
ANDRZEJ KACZMAREK

*Institute of Turbomachinery, Technical University of Łódź*

*e-mail: dkozan@p.lodz.pl; zkozan@p.lodz.pl; tlech@p.lodz.pl; akaczm@p.lodz.pl*

A magnetic bearing system of a rotating shaft is characterized by a unique feature that consists in the possibility of monitoring static and dynamic loads (reactions) of each bearing under normal operation of the machine. In the paper, an identification procedure of bearing response forces, which allows for simultaneous measurement of the journal position with respect to the bush and the control currents that flow in magnetic bearing bush windings, is presented. The proposed procedure ensures effective protection of the rotating shaft supported in active magnetic bearings against too high loads and displacements that can occur in the rotating system. Experimental investigations were carried out on test rigs with the shaft supported in active magnetic bearings.

*Key words:* dynamics, magnetic bearing, load, identification, control

### 1. Introduction

The search for new solutions of bearing systems in turbomachinery that have to satisfy special performance demands has resulted in the interest in rotor active magnetic suspension systems. New solutions in bearing systems have been more and more frequently applied in modern rotating machines. An active magnetic bearing system is a qualitatively different technology in comparison with classical solutions and requires co-operation of specialists from two branches of technology as it is a combination of a mechanical system with an electronic automatic control system which controls this mechanical system (Schweitzer *et al.*, 1993; Kozanecka, 2000, 2001).

Application of this advanced technology to the design of machines with special performance requirements leads to the search for new, optimal designing methods of bearing measurement and control systems. Unique properties of active magnetic bearings allow us to consider their application to machines that are particularly liable to damage due to external excitations (Kozanecka *et al.*, 2003).

## 2. Bearing load identification

The magnetic bearing response vector is a sum of forces generated by bearing electromagnets. It alters in each control cycle.

The value of each component force  $F_m$  [N] is connected with the mean value of the control current  $I$  [A] measured in a given control cycle and the value of the magnetic gap  $S$  [m], whose value is found by measuring the instantaneous journal position with respect to the center of the bush, whose clearance is known. The value of each response force component is also a function of the bearing constant  $K$  [Nm<sup>2</sup>/A<sup>2</sup>], which depends on bearing design parameters and can be calculated theoretically. In order to increase the accuracy of the proposed measurement method of the magnetic force, the constant  $K$  is verified experimentally for each bearing (Kozanecka *et al.*, 2001, 2002, 2003). In Fig. 1, some exemplary results of the identification of the magnetic bearing dynamic response, connected with an occurrence of synchronous excitation due to unbalancing, are shown.

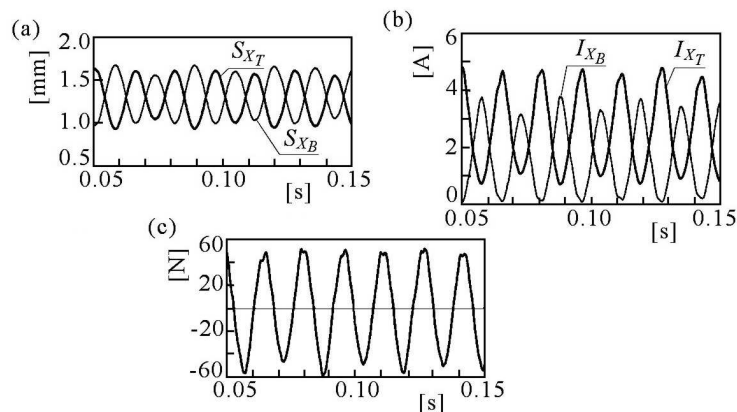

Fig. 1. Changes in the gap (a), currents (b) and the bearing response force (c) versus time for the control axis  $X$

Figures 1a and 1b present changes in the gap  $S$  and the currents  $I$ , in the top ( $S_{X_T}, I_{X_T}$ ) and bottom ( $S_{X_B}, I_{X_B}$ ) pair of electromagnets of the journal

bearing, respectively, for the control axis  $X$  as a function of time. These changes result in the calculation of the magnetic force response of the bearing along the axis  $X$  (Fig. 1c). The identification procedure of the bearing response forces comprises various configurations of the measurement system, which allows for simultaneous measurement of the journal position with respect to the bush and the control currents that flow in magnetic bearing bush windings.

### 3. Test rig

The investigations were aimed at the identification of the external load related to the forces generated by the labyrinth seal through the examinations of the response forces of the bearing in which the shaft was supported.

The test rig (Fig. 2) consisted of a vertical rotor levitating in the magnetic field and controlled in five control axes (two magnetic journal bearings – 2, 3 and one magnetic thrust bearing – 4) with a system of two-stream labyrinth seal 1 of the diameter  $\emptyset 359$  mm. Application of the vertical system of the rotor allowed for the identification of unsteady forces generated by the seal through indirect measurement of the forces in one, upper magnetic journal bearing (the control axes  $X$ - $Y$ ), which was located in a direct vicinity of the model seal. In that rotor system, the bottom journal bearing did not exhibit any influence of the labyrinth seal and was characterized by a low level of relative vibrations as well as static and dynamic loads.

### 4. Identification of unsteady forces generated by the labyrinth seal

In the first stage of the investigations, an experimental verification of the magnetic bearing parameters  $X$ - $Y$  employed in the indirect measurement method of the bearing response was carried out. In the indirect measurement of the magnetic force, the knowledge of the so-called bearing constant  $K$  and instantaneous values of currents and air gaps for all 4 electromagnets is required. In practice, a relationship for the magnetic force along one axis assumes the form as follows

$$F_{X_m} = K_T \frac{I_{X_T}^2}{(S_{T_0} - x)^2} - K_B \frac{I_{X_B}^2}{(S_{B_0} + x)^2} - F_{m_0} \quad (4.1)$$

where

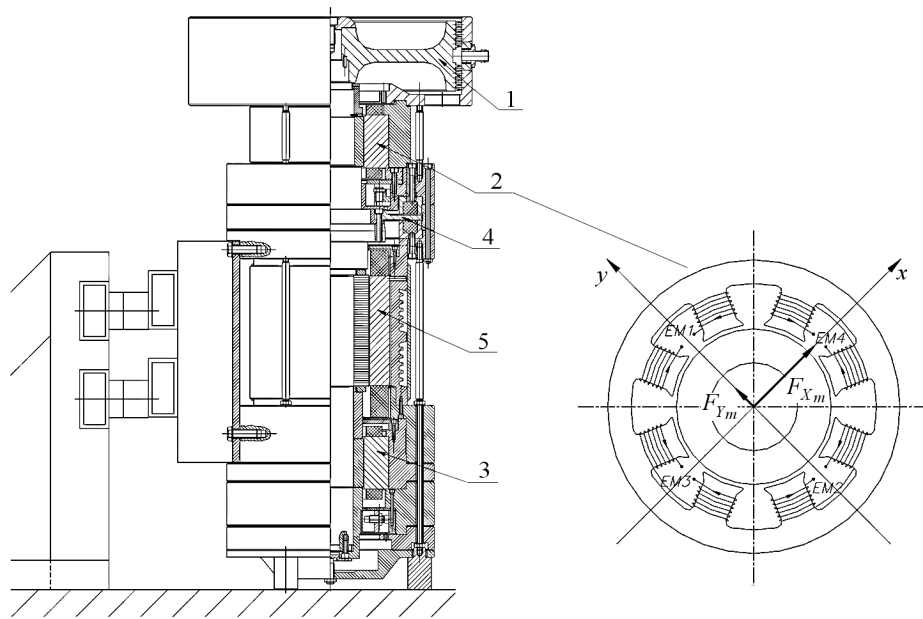

Fig. 2. A schematic view of the test rig and the magnetic journal bearing

- $I_{X_T}, I_{X_B}$  – currents in the top and bottom electromagnet [A],  
 $S_{T_0}, S_{B_0}$  – magnetic gaps of the top and bottom electromagnet  
 for the journal located in the center of the displacement  
 measurement system [ $\mu\text{m}$ ],  
 $x$  – journal displacement [ $\mu\text{m}$ ],  
 $K_T, K_B$  – top and bottom electromagnet constants [ $\text{N}\mu\text{m}^2/\text{A}^2$ ],  
 $F_{m_0}$  – correction constant [N].

After the verification procedure of the magnetic bearing parameters, experimental investigations of the seal were carried out. In order to conduct a reliable identification of the external load vector connected with the forces generated by the labyrinth seal, a comparison of the magnetic response force of the upper journal bearing for two states of the system operation, namely:

- when the seal is not supplied with the working medium,
- when the seal is supplied with the working medium,

was required.

The first state of operation of the investigated system is the background for the analysis of its state with the operating seal. A comparison of both these states provides a possibility of identification of additional forces that occur in the bearing under analysis while the seal is operating. It allows for the determination of dynamic properties of the seal and its influence on the rotating system dynamics.

The basic quantity assumed in the experiment was a step change in the pressure of the working medium in the seal under consideration from the value of  $p = 1$  bar up to  $p = 4$  bar. The pressure was measured with a pressure transducer manufactured by Aplisens, of the range of  $p = 10$  bar, and recorded in each measurement cycle. The measurements were taken at a constant angular frequency equal to  $n = 35$  Hz.

The parameter for each measurement series was the given seal eccentricity  $e_V = 0.13, 0.26, 0.39, 0.52$ , which was obtained through introduction of the defined, constant value of displacement for the control axis of the journal bearing.

The driving system of the test rig (Fig. 2) consisted of engine 5 integrated with the shaft and driven by a frequency converter. In order to eliminate possible disturbances caused by the driving system and the measurement and recording procedure of the results for the given eccentricity  $e_V$ , the rotating system was started up to reach the required frequency  $n = 35$  Hz, and then the driving system was switched off. Under such conditions, the measurement and recording of the following parameters of the journal bearing which are indispensable to determine the response forces according to the method developed, namely:

- instantaneous changes of the displacement [ $\mu\text{m}$ ] along the axes  $X$  and  $Y$  of the bearing,
- instantaneous changes of currents [A] in the windings of each pair of bearing electromagnets,

were carried out.

During the recording procedure, the operating conditions of the seal were altered, that is to say, the pressure of the working medium feeding the seal of the value  $p = 4$  bar was provided in a step-like manner. The measurement and recording of displacements and currents comprised the whole sequence of the seal operation with and without feeding by a working medium.

The next stage consisted in the processing of the results recorded, and its final effect was the identification of instantaneous changes in the magnetic response force for individual axes of the bearing  $F_{X_m}$ ,  $F_{Y_m}$ , the determination of their average values, and the determination of the resultant magnetic force and its average value  $(F_m)_{av}$ . In order to determine instantaneous changes in the magnetic response forces under the known operating conditions of the seal  $p = 1$  bar and  $p = 4$  bar, the known eccentricity  $e_V$  and the given frequency  $n$ , the averaged values of the displacement  $X_{av}$ ,  $Y_{av}$  and the bearing electromagnet currents  $(I_{X_T})_{av}$ ,  $(I_{Y_T})_{av}$ ,  $(I_{X_B})_{av}$ ,  $(I_{Y_B})_{av}$  were required. The obtained values of the displacement made it possible to generate the  $X$ - $Y$  orbits.

## 5. Exemplary results of the investigations

Some sample results of the analysis of static forces acting on the rotor in relation to the operation of the labyrinth seal for three measurement series are presented in the Table 1. For the known operating conditions (the frequency of shaft rotations  $n$ , the labyrinth seal eccentricity  $e_V$ ), the static components of the magnetic response forces  $F_m$  were measured, and then the increments of these responses related to the operation of the labyrinth seal  $\Delta F_m$  were calculated, which allowed for finding the components of the force  $F_{seal}$  with which the seal acts on the rotor. The results were recorded in a form of plots presenting changes in the static components of the magnetic bearing response  $F_{X_m}$ ,  $F_{Y_m}$  and the static components of the labyrinth seal response  $F_{X_{seal}}$ ,  $F_{Y_{seal}}$  as a function of the seal eccentricity  $e_V$  for both the axes  $X$  and  $Y$ .

Tabela 1. Static forces acting on the rotor under different operating conditions

Series No.	$n$ [Hz]	$e_V$ -	$p$ [bar]	$F_{X_m}$ [N]	$F_{Y_m}$ [N]	$\Delta F_{X_m}$ [N]	$\Delta F_{Y_m}$ [N]	$F_{X_{seal}}$ [N]	$F_{Y_{seal}}$ [N]
1	0	0	1	-3.2	-1.2	0	0	0	0
			4	-70.9	98.7	-67.7	99.9	-53.5	78.9
2	35	0	1	0.8	-0.7	0	0	0	0
			4	-34	119.5	-33.2	120.2	-27.5	94.9
3	35	0.13	1	0	-0.4	0	0	0	0
			4	-40.3	44.5	-40.3	44.9	-31.8	35.5

## 6. Conclusions

A unique test rig of the model rotor with a five-axis active magnetic bearing system has been built. The test rig allows for investigations of the rotor dynamics under assigned operating conditions, such as angular velocity, labyrinth seal eccentricity, pressure in the seal.

The developed method of indirect measurement of the bearing response makes it possible to identify the external forces that act on the rotor. The measurement of instantaneous values of journal positions and intensities of the current flowing in bearing electromagnet windings during the system operation enables one to calculate components of the vector of the magnetic bearing response at any moment. This provides a diagnostic capability that is not to be met in any other bearing system.

The method is used to measure the forces with which the model seal acts on the rotor-bearing system through a comparison of the forces of the bearing magnetic response in two states of the system operation. The measurable changes in the static and dynamic load of the magnetic bearing make it possible to determine the forces that act on the shaft in relation to the operation of the seal under analysis. Thus, the identification of the external forces generated by the seal operation and, consequently, the determination of the dynamic properties of the investigated seal and its influence on the machine rotating system dynamics are possible.

### References

1. KOZANECKA D., 2000, Diagnostic capabilities of active magnetic bearing actuators with digital control, *Proceedings of International Conference MECHATRONICS2000*, Warsaw, Vol. II, 314-317
2. KOZANECKA D., 2001, Dynamics of the flexible rotor with an additional active magnetic bearing, *Machine Dynamics Problems*, **25**, 2, 21-38
3. KOZANECKA D., KOZANECKI Z., LECH T., 2001, Modelling the dynamics of active magnetic bearing actuators, *Proc. World Multiconference on Systems, Cybernetics and Informatics, SCI 2001*, USA, Vol. IX, Industrial Parts I, 232-235
4. KOZANECKA D., KOZANECKI Z., LECH T., 2002, Theoretical and experimental investigation of dynamics of the flexible rotor with active magnetic bearings, *Advances in Vibration Engineering*, **1**, 4, 412-422
5. KOZANECKA D., KOZANECKI Z., LECH T., ŚWIDER P., 2003, New concept of the spin test system with active magnetic bearings, *Proc. of the 2nd Int. Symp. on Stability Control of Rotating Machinery*, Bently Nevada Corporation, 199-208
6. SCHWEITZER G., TRAXLER A., BLEULER H., 1993, *Magnetlager*, Springer-Verlag, Berlin [in German]

### Zastosowanie aktywnych łożysk magnetycznych do identyfikacji sił generowanych w uszczelnieniu labiryntowym

#### Streszczenie

System łożyskowania magnetycznego wirującego wału charakteryzuje unikatowa możliwość pozwalająca na monitorowanie obciążeń statycznych i dynamicznych (reakcji) w czasie pracy maszyny. W artykule przedstawiono procedurę identyfikacji sił

reakcji łożyska, pochodzących od działającego uszczelnienia labiryntowego, która polega na jednoczesnym pomiarze pozycji czopa w panwi oraz prądu płynącego w uzwojeniach elektromagnesów panwi. Eksperymentalną weryfikacją procedury przeprowadzono na stanowisku badawczym maszyny z wałem podpartym w aktywnych łożyskach magnetycznych.

*Manuscript received August 3, 2006; accepted for print October 18, 2006*