

J. ADAMCZYK* , M. SULIGA* , J.W. PILARCZYK* , M. BURDEK**

THE INFLUENCE OF DIE APPROACH AND BEARING PART OF DIE ON MECHANICAL-TECHNOLOGICAL PROPERTIES OF HIGH CARBON STEEL WIRES

WPLYW CZĘŚCI ROBOCZEJ I KALIBRUJĄCEJ CIĄGADŁA NA WŁASNOŚCI MECHANICZNO-TECHNOLOGICZNE DRUTÓW ZE STALI WYSOKOWĘGŁOWEJ

In this work the influence of the die approach and bearing part of die on mechanical-technological properties of high carbon steel wires has been assessed. The drawing process of $\varphi 5.5$ mm wires to the final wire of $\varphi 2.9$ mm was conducted in 6 passes, by means of a multi-die drawing machine Koch type. The drawing speeds in the last passes were: 7 m/s. For wires drawn according to four variants the investigation of mechanical-technological properties has been carried out, in which yield strength, tensile strength, uniform and total elongation, reduction of area, the number of twists and the number of bends were determined. On the basis of numerical analyses wire drawing process, the influence of geometry of die on redundant strain and effective strain has been determined.

The investigations have shown the essential influence of geometry of die on mechanical-technological properties of high carbon steel wires. It has been shown that the increase of strength properties in wires drawn with high die angle is related to the occurrence in their bigger effective strain.

Keywords: high carbon steel wires, mechanical properties, die geometry

W pracy określono wpływ części roboczej i kalibrującej ciągadła na własności mechaniczno-technologiczne drutów ze stali wysokowęglowej. Proces ciągnięcia drutów o średnicy 5,5 mm na średnicę końcową 2,9 mm zrealizowano w 6 ciągach na ciągarce wielostopniowej typu Koch. Prędkość ciągnięcia na ostatnim ciągu wynosiła 7 m/s. Dla drutów ciągniętych według czterech wariantów ciągnięcia, przeprowadzono badania własności mechaniczno-technologicznych, w których określono umowną granicę plastyczności, wytrzymałość na rozciąganie, wydłużenie równomierne i całkowite, przewężenie, liczba skręceń i liczbę zgięć. Natomiast w oparciu o analizę teoretyczną procesu ciągnięcia określono wpływ geometrii ciągadła na odkształcenia postaciowe i intensywność odkształcenia.

Przeprowadzone badania wykazały istotny wpływ geometrii ciągadła na własności mechaniczno-technologiczne oraz nierównomierność odkształcenia drutów ze stali wysokowęglowych. Stwierdzono, że wzrost własności wytrzymałościowych w drutach ciągniętych z dużymi wartościami kąta ciągnięcia związany jest z ich większą intensywnością odkształcenia.

1. Introduction

The ever growing technical progress makes the demand on the designer, the engineer and the user to assure increasingly high service and operational properties of wires. The basic engineering parameters that significantly influence the properties of drawn wire include the magnitudes of single and total reductions in area, drawing speed, lubrication conditions and the geometry and type of the drawing die [1÷3]. Drawing die geometry and shape have a decisive effect on the wire properties and drawing process parameters, i.e. mechanical and

engineering properties, fatigue strength, surface roughness, temperature, strain and stress state, and drawing force [4÷7]. It has been demonstrated in studies [8÷10] based on numerical analysis and experimental tests that the proper selection of conical die parameters, such as the drawing angle and the die sizing portion angle and length, may markedly contribute to the improvement of the high-carbon wire properties. The studies quoted were carried out for wires drawn in two dies in laboratory conditions using low drawing speeds, so under conditions deviating from industrial conditions, that is multi-stage drawing with drawing speed higher by several times.

* CZESTOCHOWA UNIVERSITY OF TECHNOLOGY, FACULTY OF MATERIAL PROCESSING TECHNOLOGY AND APPLIED PHYSICS, INSTITUTE OF PLASTIC FORMING AND SAFETY ENGINEERING, 42-200 CZĘSTOCHOWA, 19 ARMII KRAJOWEJ STR., POLAND

** INSTITUTE FOR FERROUS METALLURGY, 44-100 GLIWICE, 12-14 K. MIARKI STR., POLAND

In this connection, based on experimental tests carried out under industrial conditions and on an experimental analysis, the effect of multi-stage drawing in conical dies with a varying die angle (α), bearing slope (φ), and bearing length (Lk) on the mechanical-technological properties, the amount of lubricant on the wires, redundant strain and effective strain in high-carbon steel wires was determined within the present study.

2. Material and applied drawing technologies

The test material was wire rod of C62DP grade high-carbon steel. Chemical composition of the steel is given in Table 1.

TABLE 1
The chemical composition of steel

%C	%Mn	%Si	%P	%S	%Cr	%Ni	%Cu	%Al
0.62	0.70	0.15	0.035	0.035	0.15	0.20	0.25	0.01

The wire rod was subjected to the processes of patenting, etching and phosphating. Drawing of 5.5 mm-diameter wire to a final diameter of 2.90 mm was effected in 6 draws, under industrial conditions, on a Koch multi-die drawing machine with increasing drawing speed which was 7 m/s in the last draw. Table 2 shows the distribution of single drafts, Ds, the total draft, Dt, and drawing speed, V, in particular draws for the wires from Variants 1÷4.

TABLE 2
The distribution of the single draft, Ds; the total draft, Dt and drawing speeds, V for wires from variants 1÷4

Draft	φ , mm	Ds, %	Dt, %	V, m/s
0	5.50	–	–	–
1	4.98	18.0	18.0	2.37
2	4.45	20.2	34.5	2.97
3	3.98	20.0	47.6	3.72
4	3.56	19.9	58.1	4.65
5	3.20	19.2	66.1	5.75
6	2.90	17.9	72.2	7.00

To determine the effect of die geometry on the wire properties, 4 drawing types were proposed, which different in the die angle α , the bearing slope φ , and the varying bearing length Lk, see Table 3 and Fig. 1. The length of the bearing length in Variants 1÷3 depended on the φ angle. It was assumed that in each draw (Variant1÷3), the 20% of the deformation takes place in the bearing part, while 80% in the reduction part of the

die. Hence the varying length of the bearing part in particular variants. In Variant 4, on the other hand, standard conical dies, as commonly used in industry, were used.

TABLE 3
The parameters of dies, where: dk – final wire diameter, α – die angle, φ – bearing slope, Lk – bearing length

Variant	dk, mm	α , °	φ , °	Lk	
				%	mm
1	4.98	2	1.5	40dk	1.99
	4.45	2	1.5		1.78
	3.98	2	1.5		1.59
	3.56	2	1.5		1.42
	3.2	2	1.5		1.28
	2.9	2	1.5		1.16
2	4.98	6	1	60dk	2.99
	4.45	6	1		2.67
	3.98	6	1		2.39
	3.56	6	1		2.14
	3.2	6	1		1.92
	2.9	6	1		1.74
3	4.98	10	0.5	120dk	5.98
	4.45	10	0.5		5.34
	3.98	10	0.5		4.78
	3.56	10	0.5		4.27
	3.2	10	0.5		3.84
	2.9	10	0.5		3.48
4	4.98	8	0	40dk	1.99
	4.45	8	0		1.78
	3.98	8	0		1.59
	3.56	8	0		1.42
	3.2	8	0		1.28
	2.9	8	0		1.16

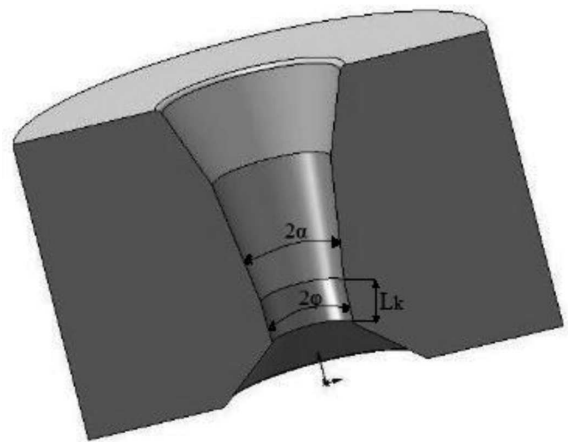

Fig. 1. The designation of the conical die, where: α – die angle, φ – bearing slope, Lk – bearing length

3. Mechanical-technological properties of drawn wires

To determine the effect of drawing die geometry on the mechanical property of the wires, tests were carried out (according to PN-EN ISO 6892-1:2009 standard) on a Zwick Z100 testing machine. For wires drawn according to Variants 1÷4, the following was determined: yield stress (YS), the ultimate tensile strength (UTS), the YS/UTS ratio, and the uniform elongation (ELU).

Figures 2÷4 represent the effect on the die shape on the variation of the yield stress, the ultimate tensile strength and YS/UTS ratio as a function of the total draft.

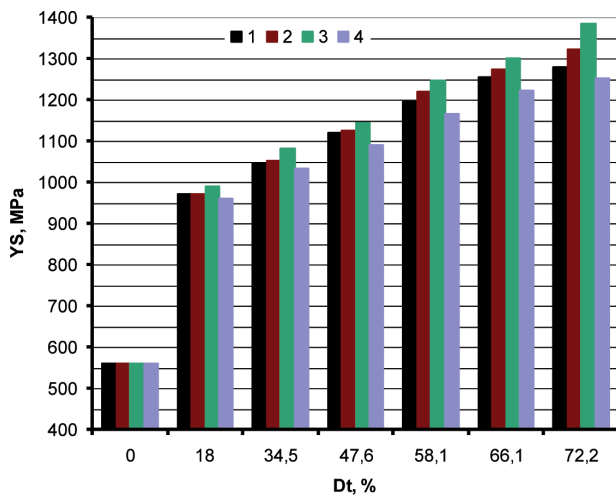

Fig. 2. Influence of die geometry on yield stress

cause an enhancement in the strength properties of the wire. The Variant 3 wires ($\alpha = 10^\circ$, $\phi = 0.5^\circ$, $L_k = 1.2dk$), as compared to the Variant 4 wires ($\alpha = 4^\circ$, $\phi = 0$, $L_k = 0.4dk$), exhibit yield stress higher by 10.7% and the ultimate tensile strength higher by 6.9%. The tests carried out indicate also that the increase of the drawing angle, with varying magnitudes of bearing slope, results in an enhancement of the strength properties of the wire. The wires from Variant 3 ($\alpha = 10^\circ$, $\phi = 0.5^\circ$, $L_k = 1.2dk$), as compared to the wires from Variant 1 ($\alpha = 2^\circ$, $\phi = 1.5^\circ$, $L_k = 0.4dk$), show yield stress higher by 8.3% and the ultimate tensile strength higher by 5.8%.

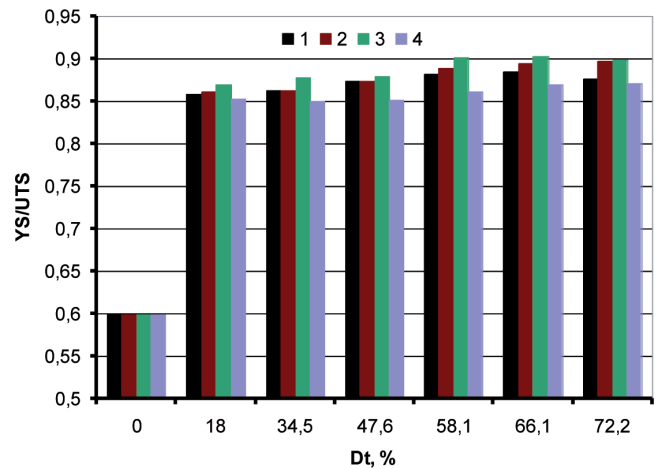

Fig. 4. Influence of die geometry on coefficient YS/UTS

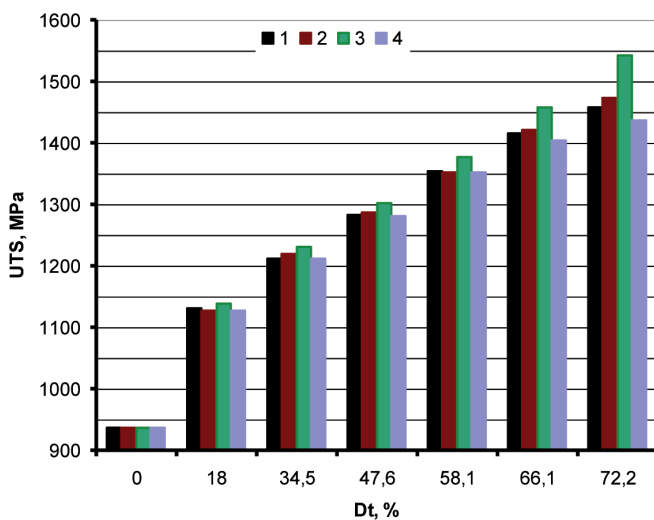

Fig. 3. Influence of die geometry on ultimate tensile strength

It can be seen from the test results in Figs. 2÷3 that the die geometry significantly influences the strength properties of high-carbon steel wires. By analyzing the strength properties of the wires drawn following Variants 3 and 4 it can be found that using a bearing slope

To better examine the yield stress and the ultimate tensile strength, the analysis of the YS/UTS ratio was made in the study. The YS/UTS ratio enables the determination of the susceptibility of wire to plastic deformation (the lower the ratio, the more plastic the material is). Figure 4 indicates that using a bearing part, as well as increasing the drawing angle in particular, negatively affects the wire plasticity. The Variant 3 wires, depending on the total draft, exhibited a YS/UTS ratio greater by approx. 3%. To confirm the negative effect of the above-mentioned die parameters on the plastic properties of wires, the variation in the uniform elongation ELU as a function of the total draft is presented in Fig. 5.

The data shown in Fig. 5 indicate that using a bearing slope and a large drawing angle of die lowers the plastic properties of the wire. The wires from Variant 3 ($\alpha = 10^\circ$, $\phi = 0.5^\circ$, $L_k = 1.2dk$), as against the wires from Variant 4 ($\alpha = 4^\circ$, $\phi = 0$, $L_k = 0.4dk$) and from Variant 1 ($\alpha = 2^\circ$, $\phi = 1.5^\circ$, $L_k = 0.4dk$), are distinguished by the uniform elongation lower by 8.2% and 10.0%, respectively.

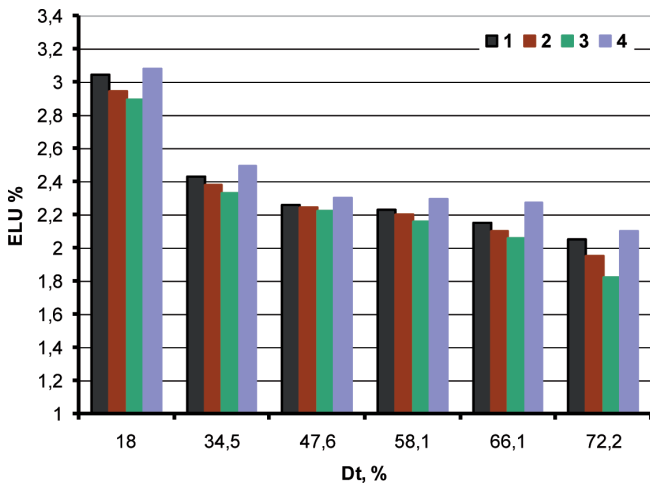

Fig. 5. Influence of die geometry on uniform elongation

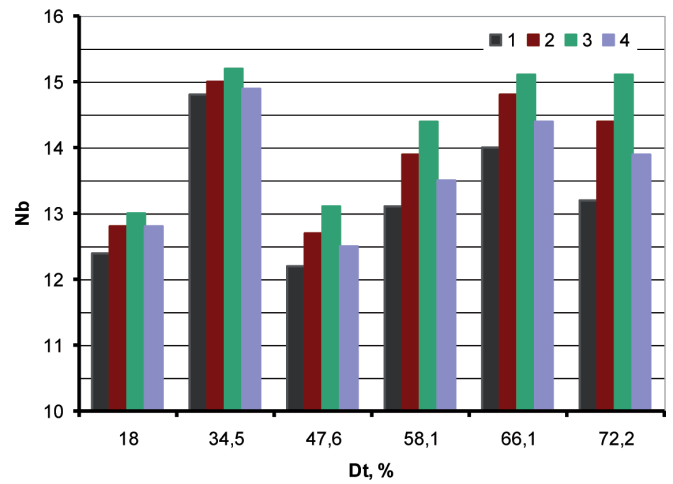

Fig. 7. Influence of die geometry on the number of bends

The parameters defining the strength properties and plasticity of wires are also the number of twists, N_t , and the number of bends, N_b . These tests reflect, in some way, the actual state of the material, because the technological properties of wire, that is N_b and N_t , are determined by both its strength and its plasticity. Therefore, technological tests of wires were carried out according to PN-EN 10218-1:2001 standard within the study. Figures 6-7 represent the variation in the number of twists, N_t , and the number of bends, N_b , as a function of the total draft for the wires drawn according to Variants 1÷4.

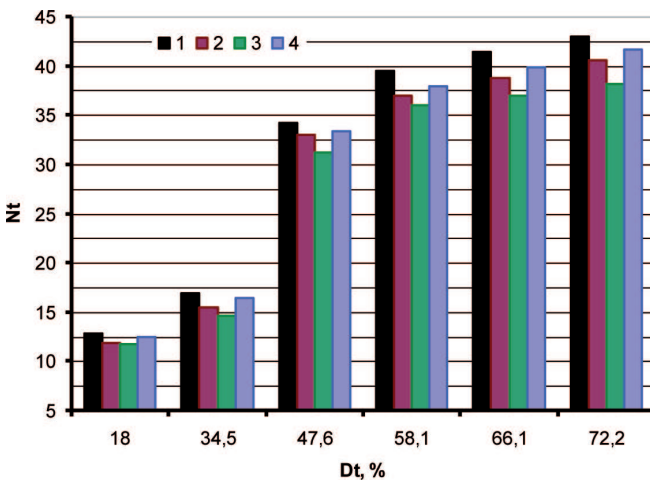

Fig. 6. Influence of die geometry on the number of twists

It can be found from the test results in Figs. 6÷7 that the bearing slope ϕ and the drawing angle α significantly influence the technological properties of wire. The wires from Variant 3 ($\alpha = 10^\circ$, $\phi = 0.5^\circ$, $Lk = 1.2dk$), compared to the wires from Variant 4 ($\alpha = 4^\circ$, $\phi = 0$, $Lk = 0.4dk$) and from Variant 1 ($\alpha = 2^\circ$, $\phi = 1.5^\circ$, $Lk = 0.4dk$), are distinguished by the number of twists smaller by 8.2% and 10.9% and the number of bends greater by 8.6% and 12.6%, respectively.

4. Effect of die geometry on the lubrication conditions in the drawing process

To determine the effect of die geometry on the conditions of lubrication in the process of drawing, the amount of lubricant on final $\varphi 2.9$ mm wires was determined. The tests results are presented in Fig. 8.

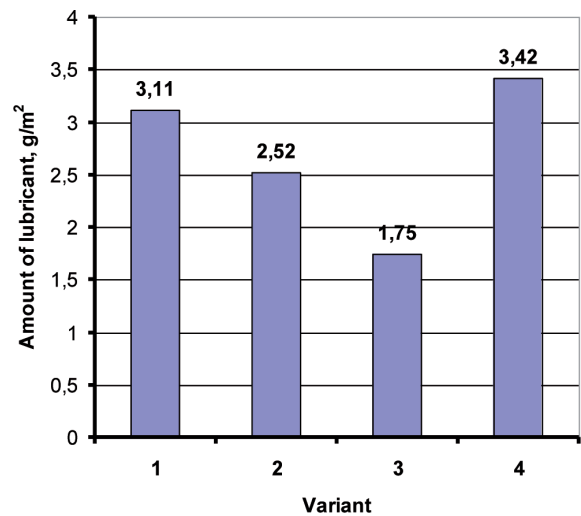

Fig. 8. The amount of lubricant on $\varphi 2.9$ mm wires drawn according to Variants 1÷4

The measurement of the amount of lubricant on the wires showed a significant effect on die geometry on the lubrication conditions in the multi-stage high-carbon wire drawing process. The data shown in Fig. 8 indicate that using a bearing slope and a large drawing angle impairs the lubrication conditions. For the wires from Variant 3 ($\alpha = 10^\circ$, $\phi = 0.5^\circ$, $Lk = 1.2dk$), a decrease in the amount of lubricant on the wires by 48.8% and 43.7%, respectively, as against the wires from Variant 4 ($\alpha = 4^\circ$, $\phi = 0$, $Lk = 0.4dk$) and from Variant 1 ($\alpha = 2^\circ$, $\phi = 1.5^\circ$, $Lk = 0.4dk$), was noted. Using the bearing slope resulted

in an increased contact between the wire and the die, hence the largest amount of lubricant was noted for the wires from Variant 4 (standard conical dies).

So, the enhancement of strength properties in the wires drawn according to Variant 3 (a large drawing angle and a bearing slope of die) should be linked with the poorer lubrication conditions for this variant and the greater hardening of the sub-surface wire layer. Therefore, the effect of die geometry on the inhomogeneity of strain in the high-carbon wire drawing process was established within the study.

5. Theoretical analysis of the drawing process

The experimental determination of the distribution of redundant strain on the cross-section of wire being drawn is difficult to accomplish, therefore a theoretical analysis of this problem was made in the study based on the Drawing 2D software [11]. Simulation of the multi-stage drawing process was performed for the rheology of pearlitic-ferritic steel C62 (~0,62 %C) using single drafts and the total draft and drawing speeds, as shown in Table 2, with a friction coefficient of $\mu = 0.07$. In addition, the parameters of dies given in Table 3 were input to the program.

The distributions of redundant strain ϵ_{xy} and effective strain ϵ_c on the surface of the wires drawn according to Variants 1÷4 as a function of the total draft are shown in Figs. 9 and 11. While Figs. 10 and 12 represent the distributions of redundant strain ϵ_{xy} and effective strain ϵ_c on the cross-section of the wires upon exit from the die sizing portion.

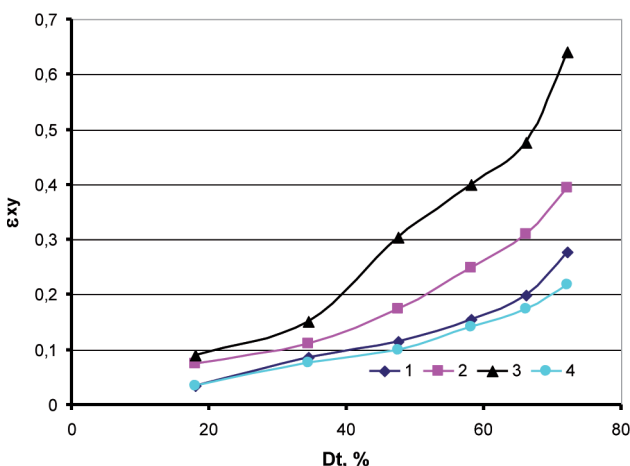

Fig. 9. The redundant strain ϵ_{xy} on the wire surface for wires drawn according to 1÷4 variants in total draft function

The tests carried out showed a significant effect of die geometry on the inhomogeneity of strain in the drawing process. The use of a bearing part and large drawing

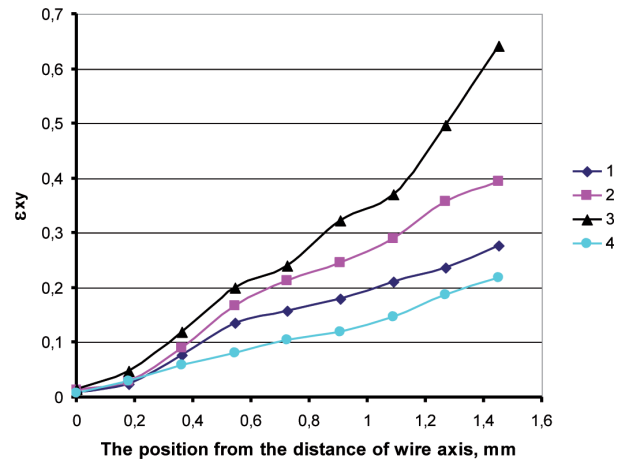

Fig. 10. The distribution of redundant strain ϵ_{xy} on the cross section of 2.9 mm wires drawn according to 1÷4 variants

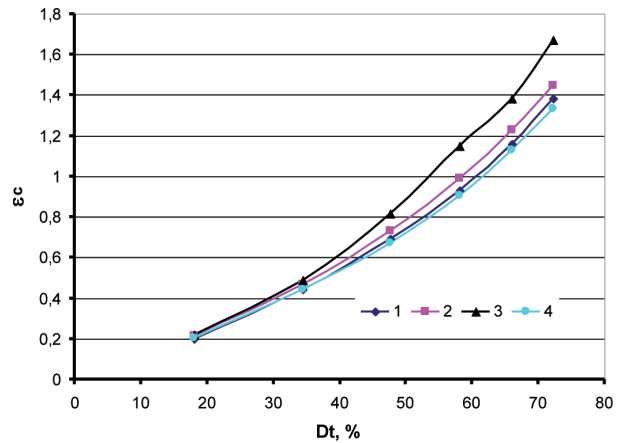

Fig. 11. The effective strain ϵ_c on the wire surface for wires drawn according to 1÷4 variants in total draft function

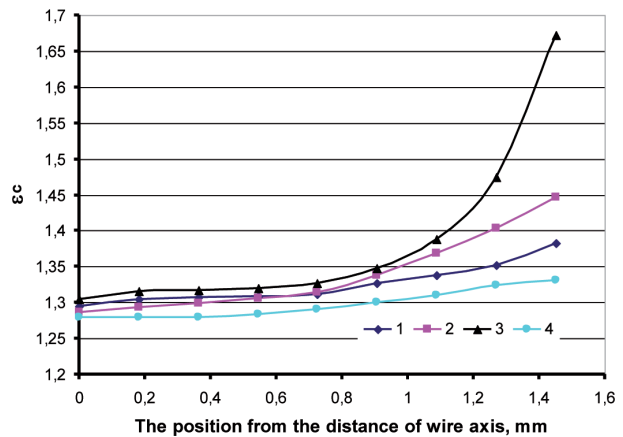

Fig. 12. The distribution of effective strain ϵ_c on the cross section of 2.9 mm wires drawn according to 1÷4 variants

angle values results in an increase in strain inhomogeneity on the wire cross-section. The differences between variants increase with the increase in the total draft, Fig. 9. The final wires from Variant 3 ($\alpha = 10^\circ$, $\phi = 0.5^\circ$, $Lk = 1.2dk$), as against the wires from Variant 4 ($\alpha = 4^\circ$,

$\phi = 0$, $L_k = 0.4dk$) and from Variant 1 ($\alpha = 2^\circ$, $\phi = 1.5^\circ$, $L_k = 0.4dk$), are distinguished by redundant strain higher by 194% and 131%, respectively (Fig. 10). The significant increase in redundant strains in the Variant 3 wires is confirmed by higher effective strain values obtained for this variant, see Figs. 11÷12.

6. Findings and conclusions

1. Die geometry, which includes the drawing angle α , the bearing slope ϕ and the bearing length of die L_k , greatly influences the mechanical properties of high-carbon steel wire.
2. The tests carried out have shown that using drawing dies with a bearing slope (Variants 1÷3) in the drawing process enhances the strength properties of wire, while impairing its plastic properties. The wires from Variant 3 ($\alpha = 10^\circ$, $\phi = 0.5^\circ$, $L_k = 1.2dk$), as compared to the wires from Variant 4 ($\alpha = 4^\circ$, $\phi = 0$, $L_k = 0.4dk$), exhibit yield stress higher by 10.7%, the ultimate tensile strength higher by 6.9%, and the uniform elongation lower by 13.3%.
3. It has been found that the increase in drawing angle, with varying bearing slope values, results in an enhancement in the strength properties of wire and a decline in its plastic properties. The wires from Variant 3 ($\alpha = 10^\circ$, $\phi = 0.5^\circ$, $L_k = 1.2dk$), as against the wires from Variant 1 ($\alpha = 2^\circ$, $\phi = 1.5$, $L_k = 0.4dk$), show yield stress higher by 8.3%, the ultimate tensile strength higher by 5.8%, and the uniform elongation lower by 11.2%.
4. It has been demonstrated that using a bearing slope of die and an increased drawing angle causes, on the one hand, a decrease in the number of wire twists (by 8%, on average), and on the other hand, an increase in the number of wire bends (averagely by approx. 10%).
5. The enhancement in the strength properties of wires drawn according to Variant 3 should be associated with redundant strains and effective strain being higher for this variant, as well as the poorer lubrication conditions.

REFERENCES

- [1] M. Suliga, The influence of the high drawing speed on mechanical-technological properties of high carbon steel wires, Archives of Metallurgy and Materials, Quarterly **56**, 3, Warszawa-Kraków, 823-828 (2011).
- [2] J. Łuksza, Elementy ciągarstwa, AGH Uczelniane Wydawnictwo Naukowo Techniczne Kraków (2001).
- [3] M. Suliga, The influence of the multipass drawing process in classical and hydrodynamic dies on residual stresses of high carbon steel wires, Archives of Metallurgy and Materials Quarterly **56**, 4, Warszawa-Kraków, 939-944 (2011).
- [4] B. Golis, J.W. Pilarczyk, Z. Błażejowski, Druty stalowe, Seria Metalurgia, 35, Wydawnictwo Politechniki Częstochowskiej, Częstochowa (2003).
- [5] Z. Steininger, Ciągnięcie drutów stalowych, Wyd. "Śląsk", Katowice (1976).
- [6] J.G. Wistreich, The fundamentals of wire drawing, Metallurgical Reviews **3**, 10, 97 (1958).
- [7] F. Knap, Naprężenia własne w ciągnionych drutach i wyrobach z drutu, Seria Monografie, 25, Wydawnictwo Politechniki Częstochowskiej, Częstochowa (1991).
- [8] B. Pikos, J. Michalczyk, J. Krnać, A. Milenin, J.W. Pilarczyk, Wpływ kształtu części roboczej i kalibrującej ciągnadła na siłę ciągnięcia oraz własności mechaniczne drutów. (Hutnik -Wiadomości Hutnicze) 1-2, 78-81 (2007).
- [9] B. Pikos, J.W. Pilarczyk, F. Knap, J. Krnać, Design of convex, concave and sigmoidal die. International Technical Conference Global Technologies for Emerging Markets, India, October (2006).
- [10] J. Krnać, R. Włodzik, J.W. Pilarczyk, R. Krugel, Influence of angles of approach and Bering parts of dies on mechanical properties of drawn steel carbon wire, Wire Journal International, 72-77, April (2010).
- [11] A.A. Milenin, B.P.B. Gautham, S.C. Goyal, J. Pilarczyk, Z. Muskalski, FEM simulation of wire fracture phenomena during multi-pass drawing, Wire Journal International, 93-99, October (2008).

Received: 10 May 2012.