

## MULTIFREQUENCY WIDEBAND SONAR ARRAY

ANDRZEJ ELMINOWICZ, WALDEMAR LIS\*, LEONARD  
ZAJĄCZKOWSKI

OBR Centrum Techniki Morskiej S.A., ul. Dickmana 62, 81-109 Gdynia, Poland,  
andrzej@ctm.gdynia.pl

\* Gdansk University of Technology, ul. Narutowicza 11/12, 80-233 Gdańsk, Poland,  
wall@eti.pg.pl

*This paper describes of new approach to Multifrequency Wideband Arrays (MWA), applied piezocomposite technologies of the array elements. MWA operating in transmitting (Tx) and receiving (Rx) mode on two or three bands, requires state-of-the-art technology and efficient array designing than conventional array in which separate arrays for every band or even separate Tx and Rx transducers/arrays are used. The new piezocomposite elements are designed at OBR Centrum Techniki Morskiej S.A., manufactured by Materials Systems Inc. (Littleton, USA) and tested at the cooperation with Gdansk University of Technology.*

*The article presents research and development work at the multifrequency wideband piezocomposite arrays elements. An example of dual frequency wideband Tx/Rx array with design parameters and its implementation for the dual frequency wideband sonar will be presented. The results of array elements measurements: TVR, RVS, Impedance and Phase versus frequency from 50 kHz to 500 kHz as well as beam patterns, will be also presented.*

### INTRODUCTION

The sonar system is a critical element of the mine countermeasure capability and her essential part is the array that must provide both searching and classification of the all types mines, particularly modern sea mines make in stealth technology, sometimes in harsh environmental condition (littoral zone). An operation at two or three different frequencies LF (low frequency), HF (high frequency) and sometime VHF (very high frequency) are required for modern sonar arrays thus the multielement wideband array operating in the above-mentioned frequencies is needed. Usage of the wideband frequency modulated (FM) signals provides processing leading to SNR increase and higher range resolution which significantly improving detection and classification performance. The arrays generally used classic

piezoelectric elements tapered to define frequency what caused manufacture complexity of array and electronics. We proposed using piezocomposite technology enabling few wideband resonance frequencies in one elements of array. Three different methods of elements modeling for design three types of samples predicted for operation on two separate wide bands have been used.

## 1. TRANSDUCER PROJECT

On the basis of performed research works, project of the MWA has been developed and the essential requirements for the new element (sample No. 1) of the transducer operating in low and high frequencies at first and third harmonics approaches are as follows:

- central frequency: 130 kHz and 430 kHz,
- 3 dB horizontal/vertical beamwidth: 21° and 7°,
- vertical sidelobes: -13 dB nominal,
- element TVR (re  $\mu\text{Pa}/\text{V}@1\text{m}$ ): 130 dB and 140 dB,
- maximum voltage at 2% duty cycle: 700 V<sub>rms</sub>,
- 3dB transmit bandwidth: 100 kHz to 150 kHz and 410 kHz to 450 kHz,
- RVS with 30 cm of cable (re V/ $\mu\text{Pa}$ ): -186 dB and -197 dB,
- 3dB receive bandwidth: 110 kHz to 160 kHz and 410 kHz to 460 kHz,
- manufacture technology: 1–3 piezocomposite.

The essential requirements for the new element (sample No. 2) of the transducer operating in low and high frequencies at split resonance approach are as follows:

- central frequency: 90 kHz and 190 kHz,
- 3 dB horizontal/vertical beamwidth: 21° and 7°,
- vertical sidelobes: -13 dB nominal,
- element TVR (re  $\mu\text{Pa}/\text{V}@1\text{m}$ ): 130 dB and 140 dB,
- maximum voltage at 2% duty cycle: 700 V<sub>rms</sub>,
- 3dB transmit bandwidth: 70 kHz to 110 kHz and 170 kHz to 210 kHz,
- RVS with 30 cm of cable (re V/ $\mu\text{Pa}$ ): -186 dB and -197 dB,
- 3dB receive bandwidth: 70 kHz to 110 kHz and 170 kHz to 210 kHz,
- manufacture technology: 1–3 piezocomposite.

Two types of transducer elements (samples No. 1 and No. 3) operating at the first and third harmonics and one type of element (sample No. 2) operating at split resonance approach have been modeled and designed in order to obtain required performance. It is assumed also Materials System Inc. (Littleton, USA) which is leader in designing and manufacturing high performance piezocomposite transducers for navies and defense customer will be transducer manufacturer. Modelling of TVR (Transmitting Voltage Response) and RVS (Receiving Voltage Sensitivity) versus frequency for samples operating at the first (130 kHz) and third (390 kHz theoretically but 430 kHz according with modeling results) harmonics are presented in the Figures 1 and 2.

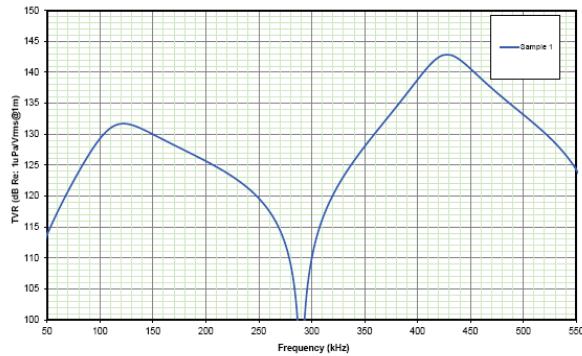

Fig.1. TVR versus frequency at the first and third harmonics.

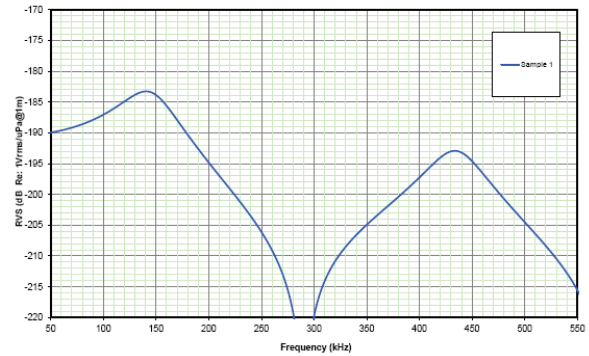

Fig.2. RVS versus frequency at the first and third harmonics.

Modelling of the transducer beam patterns with 32x25 mm (vertical x horizontal) size of elements has been performed – results examples are depicted in Figure 3.

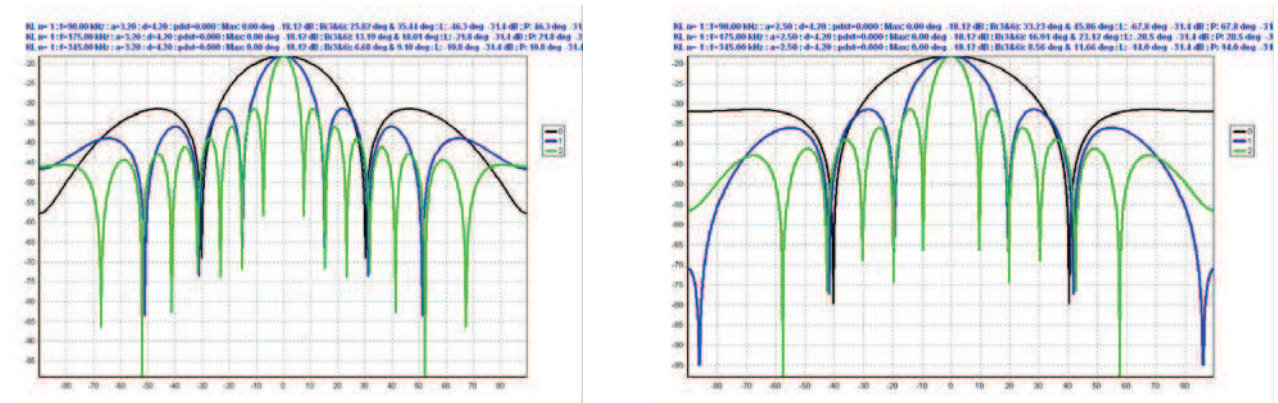

Fig.3. Vertical (left) and horizontal (right) beam patterns in angle range from  $-90^\circ$  to  $90^\circ$  for three central frequencies.

Black color - 90 kHz, blue color - 175 kHz and green color - 345 kHz

*Note: blue text over diagrams is the modelling input parameters*

## 2. TRANSDUCER TESTS

Factory acceptant test (FAT) of three different transducer elements (samples No. 1, No. 2 and No. 3) has been performed by manufacturer (MSI), FAT results are presented in Figure 4.

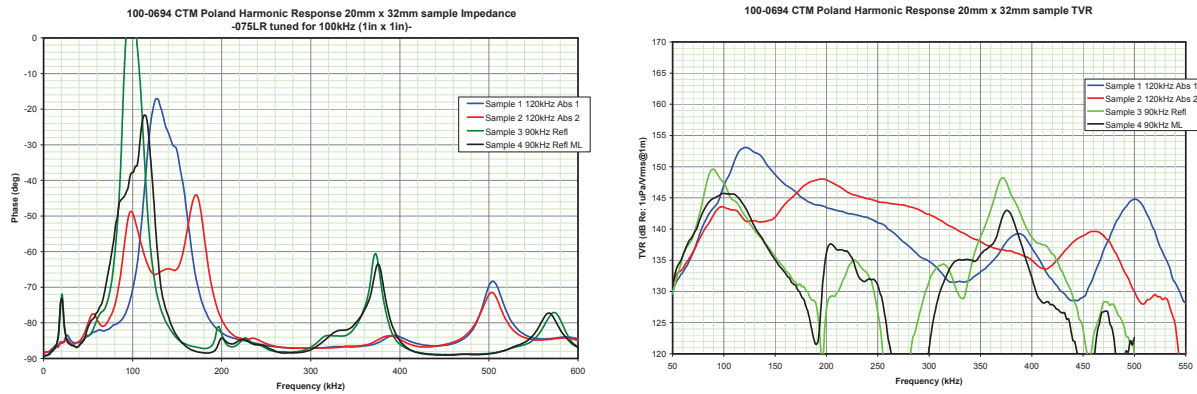

Fig.4. Examples of FAT results: phase (left) and TVR (right) Tests performed for 4 samples of transducer.

R&D MTC performed detail tests of the delivered piezocomposite elements (samples) in own small laboratory tank and in measurement basin of Gdańsk University of Technology, the following features was measured:

- impedance in air and water,
- TVR from 50 kHz to 500 kHz,
- RVS from 50 kHz to 500 kHz,
- horizontal and vertical beam patterns for two central frequencies,
- matching of Tx/Rx transducer to transmitter for selected bands.

TVS and RVS measurements have been carried out by hydrophones B&K 8104 and Reson TC4034. An example of the tests for sample No. 2 with split resonance is presented in Figure 5.

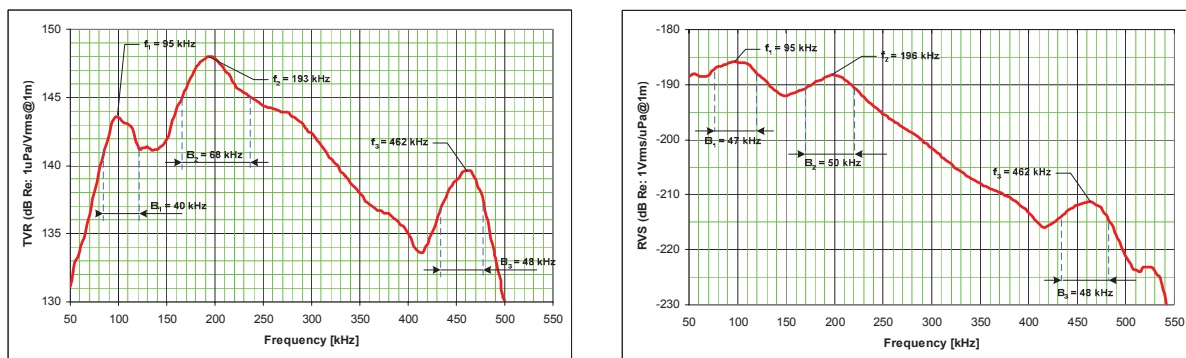

Fig.5. TVR versus frequency (left) and RVS versus frequency (right) for sample No. 2 The resonance frequencies and bands are marked.

On the basis of TVR parameters, admissible voltage and signal duration, source level (SL) was determined. The normalized SL is 190.8 dB re  $1\mu\text{Pa}/1\text{ V}/1\text{ m}$  at 90 kHz, and 193.3 dB re  $1\mu\text{Pa}/1\text{ V}/1\text{ m}$  at 170 kHz.

Results of the beam patterns measurement are presented in Figure 6. Measurements display that at 90 kHz: beamwidth is about  $40^\circ$  with side lobe levels = -17 dB and -18 dB and at 170 kHz: beamwidth is about  $17^\circ$  with side lobe levels = -13 dB and -14 dB.

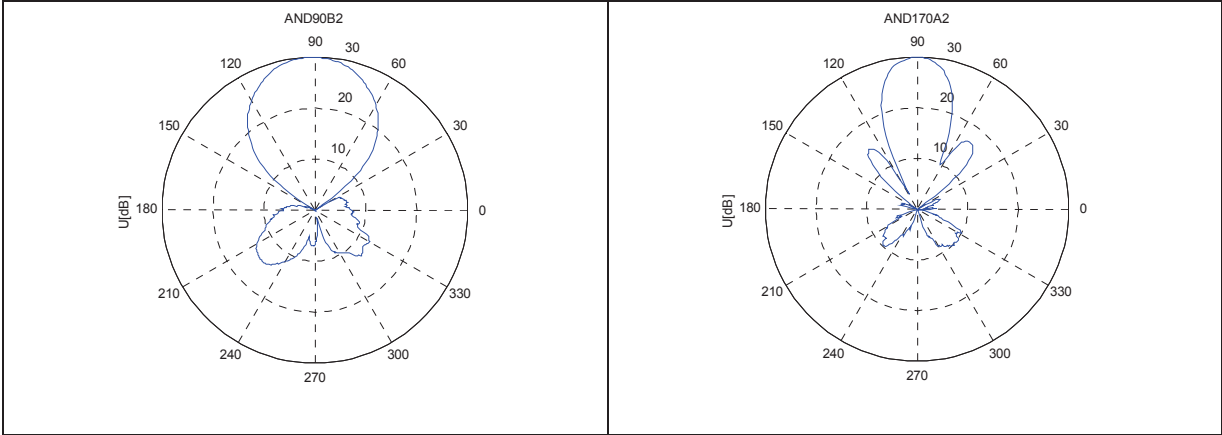

Fig.6. Beam patterns at 90 kHz (left) and at 170 kHz (right).

Measurements of transmitting characteristics, in wide frequency range from 50 kHz to 450 kHz, using steering generator sinusoidal wave at  $U_{p-p} = 2 V_{p-p}$  and duration = 0,2 ms for driving transmitter as well as matching and compensation of the transducer to band from 160 kHz to 190 kHz, has been performed. Example of the result is presented in Figure 7. It is noted that the transducer enables operate in three wide bands at 90 kHz, 175 kHz and 340 kHz and moreover slight changes of frequency resonances, their bandwidth and working levels may be adjusted by changes of matching elements parameters (L and C).

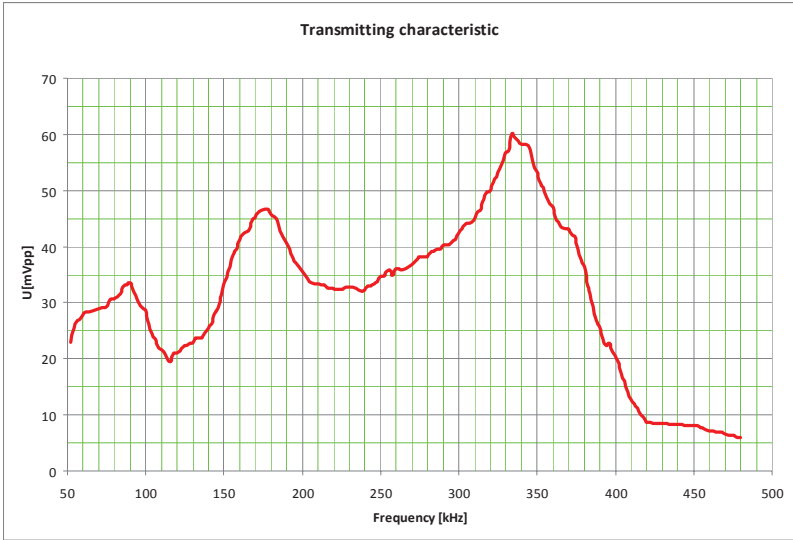

Fig.7. Transmitting characteristic of matched and compensated transducer.

To estimate obtained transmitting performance of piezocomposite transducer (estimate transducer quality) comparative measurements, with the element of Thales antenna module as comparative transducer, has been performed in this same conditions and this same

measurement equipment like at the measurement piezocomposite transducer. Result of the comparison is shown in Figure 8.

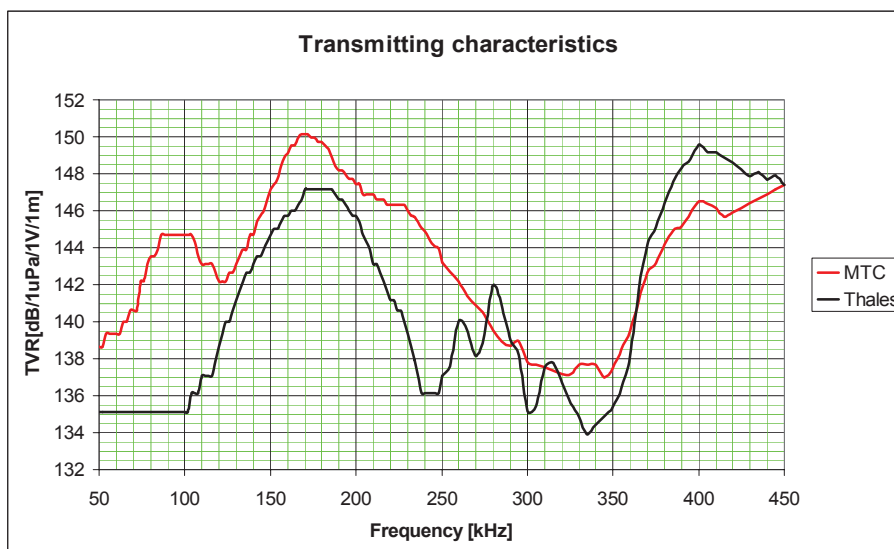

Fig.8. Comparison of transmitting voltage response (TVR) versus frequency for new transducer of R&D MTC (red) and Thales transducer (black).

### 3. CONCLUSIONS

1. Tested three delivered samples have the following features: sample No. 1 have three wide bands, main on first harmonic and the others (15 dB lower) on the third harmonic, sample No. 3 have only narrow bands and sample No. 2 have three wideband resonances with two of them on the promising TVR and RVS levels.
2. Results of tests of the piezocomposite transducer elements show that a multielement transducer composed of the piezocomposite elements may effectively operate as wideband Tx/Rx array in two or three resonance frequencies.
3. Application of the piezocomposite wideband array simplifies indispensable electronics, reduces of manufacture costs and enables all required operation modes for mine hunting.

### REFERENCES

- [1] A. Elminowicz, W. Lis, W. Męciński, Transducer for the DDS technology demonstrator, International Symposium on Hydroacoustic, Łeba, 2009.
- [2] A. Elminowicz, L. Zajączkowski, Application of wideband DDS and acoustic barrier for underwater harbour protection, MAST 2010, Roma, November 2010.
- [3] Shatalov, MY, Wallis, JR and Nicolaidis, KE. 2005. Modelling and implementation of 1-3 piezocomposite side scan sonar array. Proceedings of the International Conference "Underwater Acoustic Measurements: Technologies & Results" Heraklion, Crete, Greece, 28th June – 1st July 2005.