



Bi-modular Charge System for 155 mm Calibre Ammunition

Jiří BERÁNEK¹, Ladislav LEHKÝ²

¹ *KONŠTRUKTA – Defence, a.s., Trenčín, K výstavisku 15, SK-912 50 Trenčín, Slovakia, e-mail: beranek@kotadef.sk*

² *University Pardubice, UEM, CZ-532 10 Pardubice, Czech Republic, e-mail: lehky@seznam.cz*

Abstract. This article provides background information on issues of a Bi-modular charge system designed for a 155 mm calibre artillery system. It summarizes the principles of design and knowledge gained during the developmental stage and provides information about the firing of modules in testing 100 mm TK V20 cannon.

Keywords: mechanics, interior ballistics, Bi modular charge, cartridge chamber, propelling charge

1. INTRODUCTION – basic information

This is a further developmental stage of the design of charge systems for separated ammunition; we can say that these are the 2nd generation modular charges as presented in [1]. The complete Bi-Modular Charge System (BiMCS) represents in its design substance the solution of charge systems by two types of modules: A bottom Charge module – E (BC-E) and a top Charge module – F (TC-F). The BC-E module serves for covering of small ranges of fire (it consists of one Zone-1 module and two Zone-2 modules). Type of TC-F module serves for covering of long and maximum ranges of fire (it comprises of three to six modules – Zone – 3, 4, 5 and 6).

The BiMCS system is designed in a way that the combines both types of modules, i.e. BC-E and TC-F together, since the internal ballistics logics do not presume their interaction.

The solution of that BiMCS gives considerably reduces the demands on logistical support, and mainly increases the speed of the preparation of ammunition for firing on one hand and reduces the risks of errors on the other hand. First and foremost this BiMCS was designed for the length of the barrel of 52 calibres and a cartridge chamber volume of 23 litres.

Based on the ballistic tests it can be said that the BiMCS can be used also in weapon systems with barrel lengths of 39, 45 and 47 [3] calibres with the cartridge chamber volume ranging from 18 to 25 litres, which covers a wide range of weapon systems in service. Although using the BiMCS in weapon systems of various manufacturers with the parameters mentioned above may be considered as a universal pattern, design of modules may not necessarily be optimal for the given weapon and therefore a certain design modification of charge geometry would need to be adjusted.

The substantial part of the entire task was designing the ballistic solution for large calibre ammunition, combustible ammunition components and other system components (ignition system, deterrent, de-coppering agent, flash reducer, etc.) as well as – the verification possibility of the testing in the testing cannon. Both outlined modules which create the complete BiMCS may be demonstrated as follows:

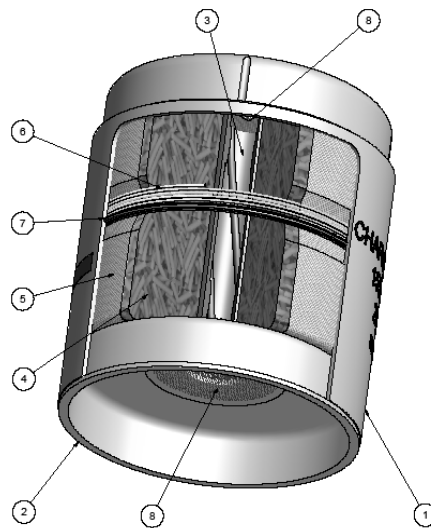

Fig. 1. BC-E module

- 1 – combustible case, 2 – combustible cover, 3 – ignition set, 4 – powder charge – single-base multi-perforated grain powder, 5 – cloth cover, 6 – de-coppering agent, 7 – cord, 8 – cover foil for ignition set

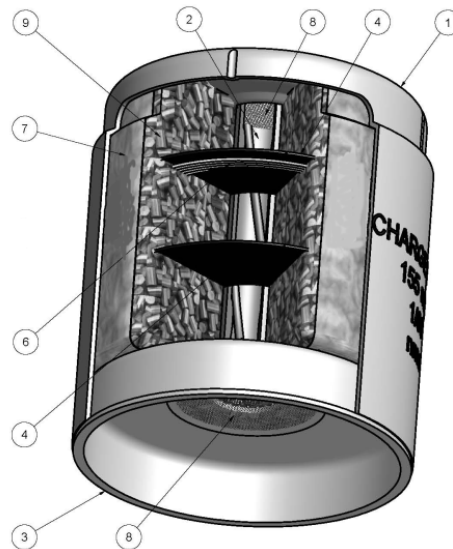

Fig. 2. TC-F module

1 – combustible case, 2 – ignition set, 3 – combustible cover 4 – flash reducer, 6 – de-coppering agent, 7 – powder charge of plastic cover, 8 – cover foil for ignition set, 9 – powder charge – single-base multi-perforated grain powder

The approach to the development of the BiMCS has been characterized by the constituting interior ballistic project (study) carried out as the basic theoretical processing of design requirements for a single module where correlative inputs like reaching required muzzle velocities and pressures – while using individual partial configurations of modules as well as the full configuration consisting of 6 modules – were also computed.

Bearing in mind the low financial resources for the testing, the tests were conducted in an effective manner in testing the 125 mm calibre gun up-gunned on 100 mm calibre. Only after satisfactory results of the targeted variants of BC-E and TC-F modules were tested in the proper 155 mm calibre weapon.

2. THEORETICAL PART

The testing of the 100 mm TK V20 cannon stood as the tool for the verification of the interior-ballistic performance of the designed BiMCS modules.

It is due to testing the 100 mm TK V20 cannon that enables the testing of the complete configuration of modular charges in quantities of 1, 2, 3 and 4 pieces so far that TC-F modules in the quantities of 3, 4, 5 and 6 pieces are used in 155 mm calibre artillery systems highlighted with volume of 23 litre cartridge chamber.

The targeted pressure has been measured with two piezoelectric sensors placed at the bottom of the cartridge chamber and near the bottom of the projectile.

The objective was to follow the pressures at the bottom of the projectile as well as at the bottom of the cartridge chamber in the initial phase of the round development. In case the pressure at the bottom of the projectile overtakes the pressure at the bottom of the cartridge chamber in its initial phase of the round development, it caused a clear demonstration of the wave action.

All the tests were performed in accordance with the established methodology of ballistic tests of smokeless powders and charges. In this case the barrel must be of a ballistic category which means that the velocity loss of a particular round cannot be more than 2%. An acceptance test assessment of the weight of the particular module is carried out at three weight levels.

The variance of muzzle velocities serving for checking the “homogeneity” of charges under testing was defined as follows:

Variance in the group of rounds with several levels of powder charge weight:

When the weight of the powder charge of the tested rounds has been tested in a single group, the probable deviance is then calculated according to the following formula:

$$\sigma = \sqrt{\frac{\sum_{i=1}^n (V_{0i} - V_{0stř.})^2}{n-1}} \quad (1)$$

$$U_{V_0} = 0.6745 \sigma.$$

When considering firing with different weights of charges and different number of rounds, a linear regression function of V_0 depending on the weight of the charge is then calculated as follows:

$$V_0 = a + b\omega \quad (2)$$

where a and b are determined regression coefficients.

For the compliance of the “calculated determined mean” values with those of gained after the firing, an equivalent to the probable deviation mentioned above can be calculated as follows:

$$\sigma_{REG} = \sqrt{\frac{\sum_{i=1}^n (V_{0i} - V_{0iREG})^2}{n-1}} \quad (3)$$

$$U_{V_0REG} = 0.6745 \sigma_{REG}.$$

The formula V_{0iREG} is a value of velocity determined from linear regression relationship (2) for i -level of weight ω_i of the powder charge tested by firing.

$$V_{0iREG} = a + b \omega_i,$$

This relationship is equivalent to the formula for one weight of charge being tested (1).

Ballistic tests of TC-F in the testing cannon includes series of check, namely checking of individual components, preliminary acceptance test assessment of the powder charge, checking of round development and checking of wave progression of pressures.

In our case the tests were performed with the configuration of powder charges 4x TC-F and 2x TC-F.

The definitive acceptance test assessment of the weight of the TC-F charge was done with a full number of modules, i.e. 5x TC-F in a proper 155 mm/39 Cal. gun, as well as 6x TC-F in both proper 155 mm/45 Cal. and 155 mm/52 Cal. guns.

The acceptance test assessment was carried out by firing two valid three-round groups with two different weights of the powder charge with a full number of modules. The weight of the charge was preliminarily defined by firing from the 100 mm TKV20 testing cannon; wave characteristics of the powder charge were verified at the same time. In addition, another three-round group with three modules with an estimated weight of the powder charge was fired so far that a total of 9 valid rounds were fired.

3. EXPERIMENTAL SECTION

a) Test results for the module charge TC-F tested in the 100 mm TK V20 cannon provided the pattern for the performance and wave processes. The following table shows the obtained outputs and measured values.

Table 1. Table of results of selected rounds (100 mm TK V20 testing cannon, type of projectile 100 mm PSvE, weight 14.4 kg)

Ser. No.	Type of charge	Time Act. [ms]	Velocity V_{40} [m/s]	Piezo M_1 [MPa]	Piezo M_2 [MPa]	- Δ Piezo M_1-M_2 [MPa]
11	4x TC-F	101	819.3	228.8	215.1	2.0
12	4x TC-F	113	815.7	225.4	213.2	6.0
13	4x TC-F	73	822.0	231.1	218.4	1.0
14	4x TC-F	120	824.1	233.1	221.6	9.0
15	4x TC-F	88	828.4	234.9	221.5	1.5
16	4x TC-F	118	839.8	239.7	227.0	10.0
17	4x TC-F	64	840.6	240.3	226.4	1.5
18	4x TC-F	149	834.3	237.6	224.9	14.0
19	4x TC-F	101	839.2	239.3	226.8	5.0

Note: - Δ Piezo – the differential pressure on the bottom of cartridge chamber and bottom of the bullets in during firing process, maximum difference.

The figures below show examples of measured pressure waveforms and pressure differences of rounds fired from the testing cannon 100 mm TK V20.

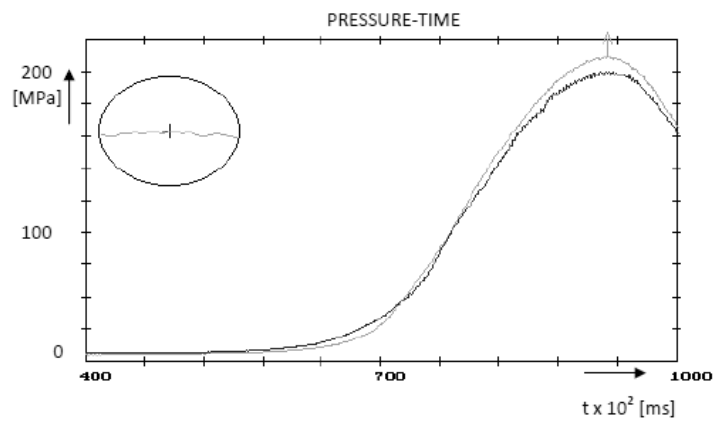

Fig. 3. Dependency of the pressure on time

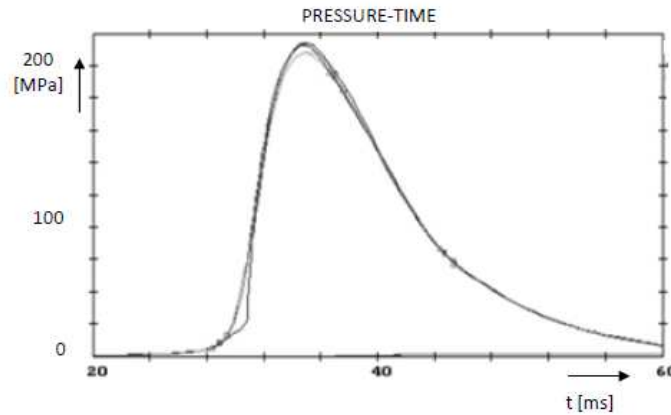

Fig. 4. Dependency of the pressure on time

b) Test results of module charge TC-F at the 155 mm/45 Cal.gun.

Projectile OFd-Mk (hollow base) was fired from 155 mm/45 Cal.gun. The representative weight of the projectiles was 43.55 kg. Firing tests measured by piezoelectric pressure measuring points. The velocity was measured by two pairs of electromagnetic frames. The pressure was measured with a pair of pressure crusher gauges with copper cylindrical crushers 8/13, a pair of pressure crusher gauges with copper ball crushers and two piezoelectric sensors. Piezosensors were placed on the 155 mm/45 Cal. cannon at a distance of 330 mm (M_1) and 930 mm (M_2) from the bottom of the cartridge chamber. The temperature of powder charges before firing was registered at 21°C, 50°C and 62.5°C.

Table 2. Test performance results of TC-F (155 mm/45 Cal. cannon, type of projectile 155 mm OFd-Mk, weight 43.55 kg)

No.of rounds	Charge	Temp. [°C]	Vo [m/s]	P_{cu} cylinder 8/13 [MPa]	P_{cu} ball [MPa]	Piezo M_1 [MPa]	Piezo M_2 [MPa]	- Δ Piezo M_1 - M_2 [MPa]
2	3x VAR4	21	547.3	93.5	107.9	101.8	100.6	2.7
2	3x VAR4	62	556.1	94.5	108.3	102.8	101.9	2.9
2	4x VAR4	21	680.1	143.8	173.0	167.6	164.4	4.4
2	5x VAR4	21	807.8	227.7	264.8	255.1	245.4	3.0
2	6x VAR4	21	935.4	320.8	388.1	380.8	365.0	3.9
2	6x VAR4	50	948.5	335.9	398.4	390.0	376.5	4.6
2	6x VAR4	62	958.2	343.6	415.9	405.0	391.6	20.1

Note: - Δ – the differential pressure on the bottom of cartridge chamber and bottom of the bullets in during firing process, maximum difference.

P_{cu} – pressure measurement according to STANAG 4113

The following figures present examples of measured pressure waveforms and pressure differences for modules 3x TC-F, 4x TC-F and 6x TC-F.

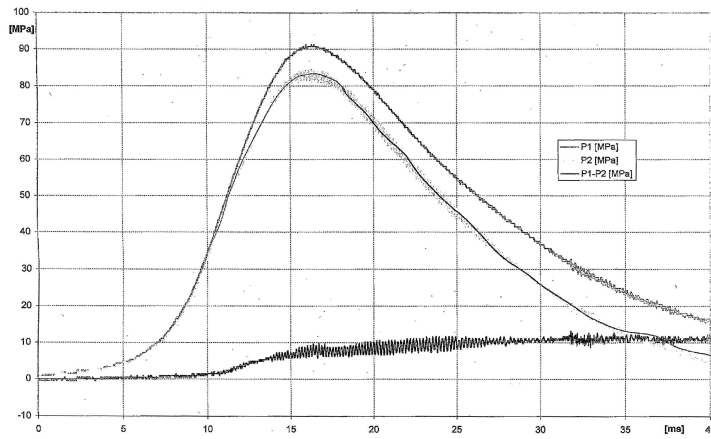

Fig. 5. Dependency of the pressure on time-charge 3xTC-F

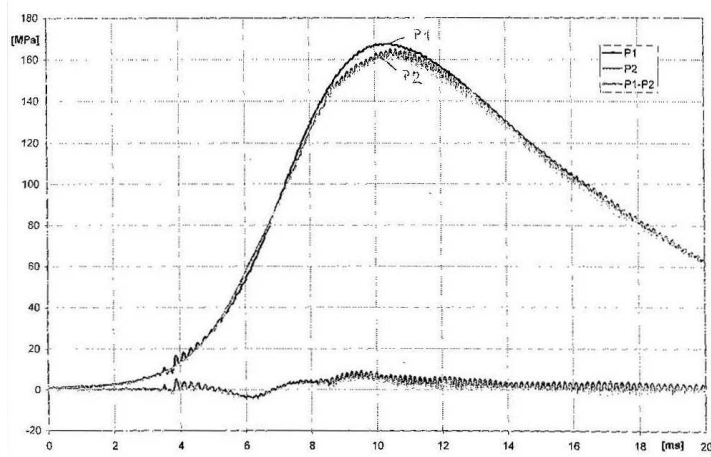

Fig. 6. Dependency of the pressure on time-charge 4xTC-F

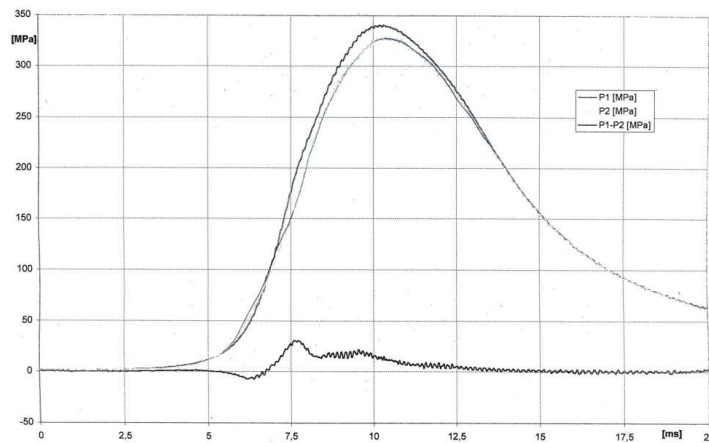

Fig. 7. Dependency of the pressure on time-charge 6xTC-F

4. DISCUSSION OF RESULTS AND CONCLUSION

The experimental exercise met its prerequisites and expectations.

As far as the comparison of the results obtained from the 100 mm testing cannon and the real 155 mm cannon, we can say that the testing cannon is a sufficient substitute for getting the first elementary interior-ballistic data necessary for the design & development of modules of BiMCS. It has been proven that the method enhances the knowledge from the point of performance characteristics of modules, possibility to find out the forming of waves during the firing and other relevant parameters regarding the development of modules of BiMCS.

By using the testing cannon it has been proven its relevance for the verification of interior ballistics of the designed modular charges and their configurations, e.g. from the point of ignition spreading and interior-ballistic parameters like dispersion as well as meeting the requirements of the so called “Ballistic memorandum” that defines all required interior-ballistic data.

Moreover, using the testing cannon gives the possibility of assessing the numeric criteria for the “quality” of wave processes as well as monitoring the quantity of unburned residues during the firing of the round from the testing cannon.

When contemplating the future tasks from the viewpoint of acceptance test assessment of the weight of powder charge for individual modules, the tests should be extended by a series of firings from a proper gun system. Such an approach based on the bigger number of comparative firing tests will definitely lead to getting more explicit real conversion coefficients.

Along with the knowledge gained from conducting and examining the tests, the final conclusion on the acceptance tests of the complete BiMCS must be supported by the firing which provides the real gun system.

REFERENCES

- [1] Pengelley R., Modular charge systems mature for global artillery operations *JANE'S INTERNATIONAL DEFENSE REVIEW*, vol. 37, no 2, pp. 32-39, 2004.
- [2] *155 mm Artillery Modular Charge System* RHEINMETALL AG, commercial prospectus.
- [3] Bonnband T., Gerrois P., Paulin J.L., French Modular Artillery BCM and TCM Charge System for 155 mm, *Proceedings of The 36 Annual Gun and Ammunition Symposium*, San Diego, USA, no 4, 2001.