

Working parameters of the electron-beam-generated ion source for ISOL facilities

Yuriy V. Yushkevich,
Marcin Turek,
Dariusz Mączka,
Krzysztof Pyszniak,
Bronisław Słowiński,
Yuriy A. Vaganov,
Jarosław Zubrzycki

Abstract. An electron-beam generated plasma (EBGP) ion source for nuclear spectroscopy purposes at YASNAPP (YAdernaya Spektroskopya NA Putschkah Protonov – nuclear spectroscopy using proton beams) isotope separation on-line facility is presented. Working conditions both in on- and off-line mode are presented and discussed. Formation of a potential trap inside a discharge chamber is an advantage of the presented construction, enabling relatively high ionization efficiencies (2–5%) even for hard-to-ionize elements like Be, Ti, V, Zr, Nb, Mo, Tc, Ru, Rh, Hf, Ta, W, Re, Os, Ir, Pt. The paper presents estimation of critical values of working parameters that enable formation of the ion trap leading in consequence to high efficiency of ionization. The optimal temperature of the discharge chamber and cathode walls is found to be in the range 2600–2800 K. Calculations of the output rates of ions produced in the on-line mode are also presented as well as the constraints on the half-life time of obtained nuclides imposed by construction details like the target material and its thickness.

Key words: on-line isotope separation • short-lived nuclides • nuclear spectroscopy • ion sources

Yu. V. Yushkevich, Yu. A. Vaganov
Joint Institute for Nuclear Research,
6 Joliot-Curie Str., 141980 Dubna,
Moscow region, Russia

M. Turek, K. Pyszniak
Institute of Physics,
Maria Curie-Skłodowska University,
1 M. Curie-Skłodowskiej Sq., 20-031 Lublin, Poland

D. Mączka[✉], B. Słowiński
Institute of Atomic Energy POLATOM,
05-400 Otwock/Świerk, Poland,
Tel.: +48 22 718 0100, Fax: +48 22 779 3481,
E-mail: dmaczka@hektor.umcs.lublin.pl

J. Zubrzycki
Technical University in Lublin,
Institute of Technological Systems of Information,
36 Nadbystrzycka Str., 20-618 Lublin, Poland

Received: 7 November 2011

Accepted: 16 March 2012

Introduction

Efficiency of an ion source is a crucial point in nuclear spectroscopy of short-lived radioactive isotopes using ISOL facilities (isotope separation on-line) [24]. This particular feature of the ion source determines scientific usefulness of a mass separator for the study of isotopes far from stability line. Despite the many years of development [5, 16], ion sources of different types suitable for such purposes are still designed and optimized [3, 6, 10, 14, 18, 22, 23]. Ionization and effusion processes that occur in ion sources dedicated for ISOL purposes are studied both theoretically [12, 13, 15] and by means of numerical simulations [19, 27–29].

The most important features of ion sources are: short delay time (especially important in the case of short-lived radioactive species), high efficiency of the ionization and extraction of ions from the ion source, high working temperature needed to achieve a short release time and to prevent the condensation of elements with low vapor pressure [21]. These requirements are relatively well fulfilled by the EBGP (electron beam generated plasma) ion source [20]. Ion source of that type has been recently studied and optimized [7, 17] for the needs of SPIRAL-2 and EURISOL facilities.

In this article we present the construction of such a type of the ion source, which is dedicated to the YASNAPP – the ISOL facility at the Laboratory of Nuclear Problems, JINR (Dubna, Russia) [4, 11].

The ion source provides beams of many hard-to-ionize, refractory elements including Be, Ti, V, Zr, Nb, Mo, Ta, Ru, Rh, Rd, Hf, Ta, W, Re, Os, Ir, Pt and others.

In this work a brief description of the ion source construction and its principle of operation as well as a review of its characteristics are given. Estimations of values of some operational parameters (critical values of these parameters) that lead to the existence of potential trap inside the ionization chamber are also shown. Calculations of the output efficiencies of radionuclides in the on-line working mode of the source are presented and discussed.

Design of the ion source and its principle of operation

The construction of the ion source is schematically shown in Fig. 1. The discharge chamber, having the inner diameter of 10 mm and the length of 8 mm, is made of tungsten (any refractory metal that is relatively easy for machining could also be used). This part is maintained at the anode potential. During the operation of the ion source in the on-line mode, the discharge chamber walls may play the role of a target irradiated by high-energy proton beams in order to produce radioactive nuclides to be studied. Inside the discharge chamber there is a cathode, which is indirectly heated by accelerated electrons emitted by the filament. The cathode temperature is about 2800 K in order to provide sufficient electron emission. The electrons emitted by the cathode pass through the anode grid and get into the ionization volume, where they can hit and ionize neutral atoms. The presence of electrons generates the negative space charge inside the ionization chamber. Some of these electrons may oscillate in this volume. As a result, a potential trap for positive ions is created. The anode grid at the potential varying in the range 20–200 V is located approximately 0.25 mm away from the cathode. Under certain conditions, the negative space charge in the ionization chamber is larger than the positive space charge of ions created during ionization of neutral atoms. Hence, it is possible to maintain relatively high ionization efficiency of the ion source.

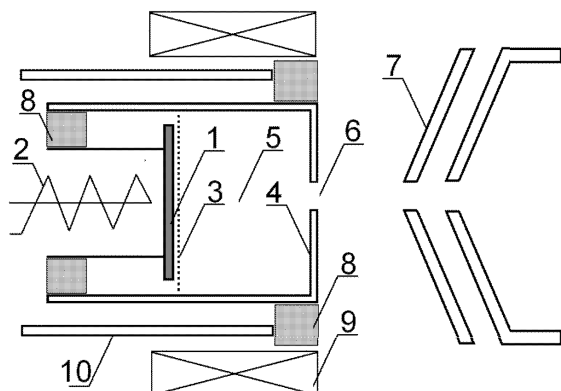

Fig. 1. Schematic drawing of the EBG ion source: 1 – indirectly heated cathode; 2 – cathode filament; 3 – anode grid; 4 – anode; 5 – ionization volume; 6 – extraction opening; 7 – extraction electrodes; 8 – insulators; 9 – electromagnet; 10 – heat shielding.

In order to initiate the discharge inside the ionization volume a buffer gas is introduced into the discharge chamber. As a rule, a noble gas like Ar, Kr is chosen as a carrier gas.

Let us assume that the described ion source works in the on-line mode (ISOL). In such a case the neutral atoms introduced into the discharge chamber are products of the nuclear reactions between high-energy protons and irradiated target atoms.

Theoretical estimations and experimental results show that in such a case the values of parameters of the ion source are the following: electron beam current density from cathode $j_e = 0.3\text{--}0.7\text{ A/cm}^2$, electron density $n_e = 3\text{--}7 \times 10^{16}\text{ m}^{-3}$, electron current $I_e = 0.5\text{--}1.2\text{ A}$, electron energy (discharge voltage) $V_d = 60\text{--}100\text{ V}$, neutral particles density $n_0 < 10^{17}\text{ m}^{-3}$ ($p = 10^{-5}\text{ Torr}$), density of the extracted ion current (Ar) $J_i^0 \approx 14\text{ A}\cdot\text{m}^{-2}$, the maximum permissible ion current (Ar) extracted from the ion source (extraction opening diameter 1.5 mm) $I_i^0 \approx 10^{-5}\text{ A}$.

For the above-mentioned conditions, the maximum extracted ion current, in the case of argon as a buffer gas, was $\sim 25\text{ }\mu\text{A}$, assuming that the outlet diameter was 1.5 mm ($2\text{ }\mu\text{A}$ for the outlet diameter 0.4 mm). These values of ion current are appropriate for ISOL facilities and allow good resolution of mass lines. The main advantage of the ion source is that the majority of ions formed in the ionization volume are extracted from the ion source because they are not lost at the walls, as they are trapped in the potential well. For example, in the case of ionization of microquantities of Kr introduced into the chamber, the total source efficiency was about 20–30%. Extracted ions are also energetically separated because ions having energy much higher than the average are able to overcome the potential barrier and are lost at the chamber wall. This results in an “ion cooling” effect favourable for mass line resolution. The nuclide staying time in the source may be estimated from the calculation of ionization efficiency. For this purpose, it is convenient to introduce the atom ionization length l_i .

$$(1) \quad l_i = ev_a / j_e \sigma_i$$

where we assumed the following values of parameters: atom velocity $v_a = 7 \times 10^2\text{ m/s}$, ionization cross-section $\sigma_i = 4 \times 10^{-20}\text{ m}^2$, and electron current density $j_e = 5.5 \times 10^3\text{ A/m}^2$. Using the above formula, it is easy to show that for our source $l_i = 0.5\text{ m}$. Then, the ionization probability P at the mean free path $l = 8\text{ mm}$ (dimension of the ion source discharge chamber) is:

$$(2) \quad P_i = l / l_i = 1.6 \times 10^{-2}$$

Assuming the ion trap is ideal, i.e. it holds all ions in the chamber, the mean staying time of nuclides in the ion source can be determined as:

$$(3) \quad \tau_0^* = \tau_a / P_i \approx 60 \tau_a$$

where τ_a is the atom sticking time on surface of the ion source walls. This means that the particle leaves the ion source as an ion after approximately 60 ($1/P_i$) collisions with chamber walls. For example, for Hf isotopes this time is about one second. If the output rate of the nuclides from the ion source is estimated on the basis

of current of their ions I_i^t at total ionization and if this current is lower than the critical current for existence of the potential trap ($I_i^0 \approx 10^{-5} \text{A}$), the ion source allows to obtain nuclides with the minimal half-life time ($t_{1/2}$) expressed by the formula:

$$(4) \quad t_{1/2} = \frac{\tau_0^*}{\ln(I_i^0 / I_i^t)}$$

The nuclide current $I_i = 10^{-13} \text{A}$ ($6 \times 10^6 \text{ at/s}$) is usually large enough to collect spectroscopic data. Then, as follows from formula (4), the EBGIP source allows to obtain nuclides with the half-life times

$$(5) \quad t_{1/2} > 0.05\tau_0^*$$

The critical value of the extracted ion current limits the total number of neutral atoms arriving in the ion source, including atoms evaporated from the source walls. This imposes some limitations on working temperature and choice of materials used for ion source parts, especially those the discharge chamber is made of.

Choice of values of the ion source working parameters

Working conditions of the ion source

It was shown in [4] and confirmed by many experiments, for example described in [1], that in spite of high yield of nuclides in interaction between the high energy proton beam and the thick target it is possible to use thin targets as a structural part of the source in the on-line investigation of short-lived nuclei far from the β -stability line. As a rule, the effective thickness of the target, ensuring the supplying of short-lived nuclides into the volume of the ion source is much smaller than the thickness of the structural elements of the source [8].

The described ion source has to operate both in off-line and on-line regimes. In the first case, which is easier from the technical viewpoint, the irradiated target is at some distance from the ion source, a mass separator or the rest of spectroscopic equipment. Such a solution is adequate for nuclides with a relatively long half-life time (hours/tens of minutes rather than seconds). Nevertheless, the problems concerning the effective extraction of nuclides from the target and the fast transport of the sample into the ion source have to be overcome – some ways to do that are mentioned in Fig. 2. The very popular solution used in the case of the off-line nuclear spectroscopy was based on a chemical

separation of produced nuclides following the solution of the target (“wet chemistry”). The separated products were placed on a metal (most often tungsten) foil by sedimentation. The sample was then transported to the spectroscopic setup. Another solution was applied in the case when a wide variety of nuclides that are hard to separate by chemical methods were produced during the bombardment (e.g. in the case of rare-earth nuclides). In such a case, an electromagnetic isotope separation is applied and the mass-separated beam of the desired nuclide irradiates e.g. tungsten foil, which is used as a sample for spectroscopic studies. The described ion source could be equipped with an evaporator, where samples could be placed via a gate-valve transfer system. Such a sample should not contain volatile components in order to keep the pressure in the source volume below its critical value ($p = 5 \times 10^{-6} - 1 \times 10^{-5} \text{ Torr}$). The temperature of the evaporator varies in the range from 1500 K up to approximately 2600 K, which allows regulation of the evaporation rate of the sample.

The on-line method characterized by placing the irradiated target inside the ion source (or making it even a structural part of the source) enables studies of short-lived isotopes. The nuclides that are produced during the target bombardment reach the ionization volume of the source due to the thermal diffusion. The targets, which are heated to high temperatures, e.g. by beams of electrons, are often made of refractory metals like tungsten or tantalum. Despite the fact that oxides and carbides are harder for machining, they are often used due to their porosity, leading to the faster thermal diffusion of impurities, which may be crucial in the case of short-lived isotopes.

The main properties of the elements which are of interest for investigations with the discussed ion source are listed in Table 1. It presents values given in Refs. [8, 26], namely the ionization potential V_i , work function ϕ , melting point T_m , temperature corresponding to the vapour pressure 10^{-6} Torr , and evaporation rate W at $T = 2600 \text{ K}$. The table contains also calculated values of the evaporation heat q_a at $T = 2600 \text{ K}$, sticking time constants for the atom on the surface ($\Delta = -\lg \tau_a$), evaporation rate constants $\lg v_a$, where $v_a = N_a / \tau_a$ (assuming that N_a is the surface density of atoms of the substance under investigation). The calculations were performed with the reference values [8] using the formulae given below:

$$(6) \quad q_a = \frac{\lg v_2 - \lg v_1}{(5040/T_1) - (5040/T_2)}$$

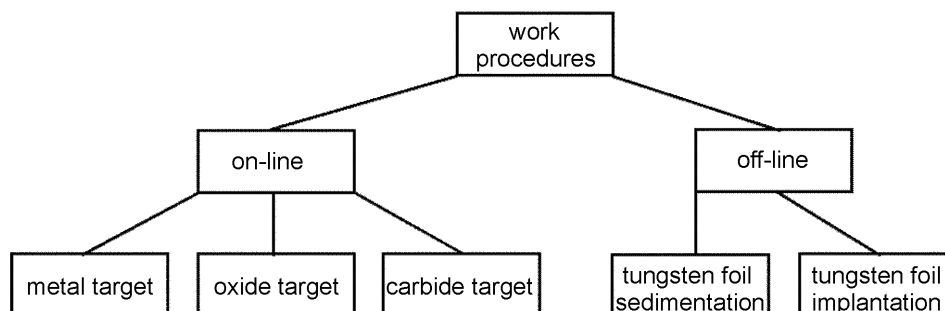

Fig. 2. Working procedures of the ion source.

Table 1. Physico-chemical properties of some refractory elements (for $T = 2600$ K)

	Be	Zr	Hf	Ta	W	Re	Os	Ir	Pt	Au
T_m (K)	1550	2125	2495	3270	3680	3453	3273	2727	2042	1336
T (K) ($p = 10^{-5}$ Torr)	1170	2110	2320	2670	2820	2640	2360	2070	1875	1260
φ (eV)	3.92	3.9	3.53	4.12	4.54	5.0	4.7	4.7	5.32	4.3
V_i (eV)	9.32	6.84	7.0	7.9	7.98	7.82	8.7	9.1	9.0	9.2
q_0 (eV)	3.16	6.66	4.7	8.25	7.5	8.13	7.69	6.35	5.54	3.54
q_0^{ex} (eV)	–	–	3.7	–	5.3–7	–	–	–	5.7	4.2
D ($\text{cm}^2\cdot\text{s}^{-1}$)	$\sim 10^{-14}$	$\sim 10^{-16}$	$\sim 10^{-11}$	$\sim 10^{-15}$	$\sim 10^{-13}$	$\sim 10^{-15}$	$\sim 10^{-16}$	$\sim 10^{-15}$	$\sim 10^{-14}$	$\sim 10^{-14}$
W ($\text{g}\cdot\text{cm}^{-2}\cdot\text{s}^{-1}$)	1.6	5×10^{-6}	6×10^{-6}	5×10^{-8}	9×10^{-9}	2×10^{-7}	4×10^{-6}	2×10^{-4}	2×10^{-3}	2.2
$\lg v_0$ ($\text{cm}^2\cdot\text{s}^{-1}$)	29.1	31.1	25.8	30.2	28.2	30.0	31.0	30.3	29.7	29.1
τ (s)	3×10^{-8}	8×10^{-4}	2×10^{-2}	4.5	14.8	3.18	0.13	2×10^{-3}	2×10^{-4}	1×10^{-7}

$$(7) \quad \lg v_a = \lg v_1 + q_a \frac{5040}{T_1}$$

$$(8) \quad \Delta = \lg v_a - \lg N_a$$

$$(9) \quad \lg \tau (2600 \text{ K}) = -\Delta + q_a (5040/2600)$$

where v_1 and v_2 are the evaporation rate constants at temperatures T_1 and T_2 , respectively. Using the values listed in Table 1 the evaporation rate of the investigated element at temperature T can be calculated as:

$$(10) \quad \lg v = \lg v_0 - q_0 (5040 / T)$$

One should have in mind that the values of heat and evaporation rates for refractory elements are practically unknown – hence, the calculated values of N_a , v_a and τ_a (or Δ) are only very rough estimations. However, Table 1 lists the known experimental values for evaporation heat q_a for W/W (W atoms evaporating from W surface) [9], Pt/W [30], Au/W [25], which shows that the agreement with theoretical estimations, at least for the purpose of the present work. Unfortunately, there is a lack of appropriate experimental data for oxides and carbides are missing in the literature.

Critical values of the source working parameters

Existence of the critical electron current density and atom concentration (saturated vapour pressure) as the conditions under which the potential trap for ions is formed in the ion source was already mentioned above. Application of the tungsten cathode and the chamber made of the same material results in a very good ionization efficiency of most elements listed in Table 1. In the on-line mode, the target may be made of the metal, isotopes of which are to be studied, or its oxides and carbides, or a metal with high atomic number. Thus, for example, during investigation of Hf and Ta it is convenient to use a tungsten target. For other elements, appropriate refractory metal targets should be chosen. The critical values of working parameters are determined by the electron emission efficiency and evaporation rates of the source and target walls. Estimations of the critical values at $T = 2600$ K for the ion source with a cathode and chamber made of tungsten yielded the following results: density of electron current emission $j_e = 0.7 \text{ A/cm}^2$, electron current $I_e = 1.4 \text{ A}$, evaporation rate of tungsten cathode $v_w =$

$8.5 \times 10^{13} \text{ cm}^{-2}\cdot\text{s}^{-1}$, concentration of tungsten atoms $n_w = 2 \times 10^9 \text{ cm}^{-3}$, tungsten ion current from the source at total ionization $I^0 = 2.9 \times 10^{-5} \text{ A}$, tungsten ion current from the source at real ionization $I_w = 1.35 \times 10^{-6} \text{ A}$, source efficiency for tungsten $\beta_i \approx 0.05$.

The current of tungsten ions produced by the ion source was calculated according to the formula presented in [20]

$$(11) \quad I_w = \chi I_e l_i \kappa_i (n_w / n^*)$$

where χ is the mean number of electron oscillations in the source ($\chi = 1.4$ at anode grid transparency 0.53), $l = 8 \text{ mm}$ (discharge chamber dimension), κ_i is the differential ionization cross-section ($\kappa_i \approx 1.5 \times 10^{-3} \text{ m}^{-1}$), n^* is the concentration of atoms at 273 K and $p = 1 \text{ Torr}$ ($n^* = 3.53 \times 10^{22} \text{ m}^{-3}$).

From the data in Table 1, it is evident that the temperature corresponding to the critical saturated vapour pressure (10^{-5} Torr) for Be, Zr, Hf, Os, Ir, Pt and Au is lower than 2600 K. This means that these elements cannot be used as targets for producing of their isotopes during interactions of high-energy protons and target atoms. Therefore, it is necessary to investigate the possibility of using oxides and carbides of these metals as targets.

The use of tungsten as a cathode material gives the possibility to increase ion source temperature up to approximately 2800 K, which corresponds to the electron emission current density 3.5 A/cm^2 . An increase of the ion source temperature leads to the decrease of the sticking times of nuclides and enables obtaining more intense beams of short-lived nuclides. However, the rise of the ion source temperature results also in a higher vapour pressure in the chamber, due to the intense evaporation of the materials the ion source is made of. Thus, the temperature $T = 2600 \text{ K}$ seems to be the optimal choice. Hence, production efficiencies of isotopes having different half-lives should be estimated for this T value.

Efficiency of the radionuclide output from the ion source in the on-line mode

During the on-line mode work of the ion source, when the discharge chamber is irradiated by swift protons, the output rate of the nuclides produced in the source is defined by many factors. These are: the particle generation rate in the irradiated target, the rate of nuclide appearance on the surface as a result of diffusion, their

desorption from the chamber/target surface, the loss caused by radioactive decay, ionization probability inside the discharge chamber, extraction efficiency as well as losses of nuclides during the transportation to the readout system.

In order to estimate the efficiency of the discussed ion source one can use the results presented in [2], describing the case of a flat target placed into a hot cavity ion source. Taking into account some changes due to the fact that the considered target is a tube of thickness δ , the output rate of the ions of the nuclides under investigation may be described by the following equation:

$$(12) \quad I_i = \frac{e\beta_i}{1+\lambda\tau^*} S_i \sigma \rho G (D/\lambda)^{1/2} th\{(\delta/2)(\lambda/D)^{1/2}\}$$

where: e is the elementary charge; β_i is the dimensionless ionization coefficient in the source, S_i is the target surface area (m^2), σ is the nuclide production cross-section (m^2), ρ is the target density (m^{-3}), G is the proton beam intensity ($\text{m}^{-2}\cdot\text{s}^{-1}$), D is the diffusion coefficient ($\text{m}^2\cdot\text{s}^{-1}$), $\lambda = (0.693/t_{1/2})$ is the decay constant (s^{-1}), δ is the target thickness (m), τ^* is the mean staying time of the nuclide on the surface of the ionization chamber governed by the adsorption (evaporation) time at the total number η of nuclide-wall collisions (s).

One can assume that $\eta \approx (1/P_i) + 1$, where $P_i \approx l/l_i$ is the atom ionization probability during a flight across the ion source chamber. Our estimation (see Eq.(3)) is $\tau^* \approx 60\tau_a = 60\tau$, where τ is the value from Table 1. The value $\beta_i \approx 0.05$ was estimated as the tungsten ionization efficiency under the conditions described by the critical values of the source working parameters (see section ‘Working conditions of the ion source’). Thus, the expression for the radionuclide output rate has the form:

$$(13) \quad I_i = \frac{e\beta_i}{1+60\tau\lambda} S_i \sigma \rho G (D/\lambda)^{1/2} th\{(\delta/2)(\lambda/D)^{1/2}\}$$

With increasing λ , the value of hyperbolic tangent tends to 1 and the nuclide output does not depend on the target thickness. In practice, the target thickness should be chosen to be comparable to the thickness of the ‘‘working layer’’ of the target, i.e. the layer from which the short-lived isotopes may reach the surface before their decay. Thus, the target thickness should satisfy the condition:

$$(14) \quad \alpha \equiv \frac{\delta}{2} \sqrt{\frac{\lambda}{D}} \geq 1$$

Using the above condition for a given δ , one can estimate the limiting values of λ or $t_{1/2}$ of nuclides that may be efficiently produced and ionized in the described ion source. These critical values of λ and $t_{1/2}$ as a function of δ are listed in Table 2 for the two values of $th(\alpha)$ (1 and 0.9). As follows from the table, for $D = 10^{-9} \text{ cm}^2\cdot\text{s}^{-1}$ and the target thickness of 1 mm, the nuclide output from the target will go on up to $t_{1/2} = 17.5 \text{ h}$ without loss and up to $t_{1/2} = 9 \text{ d}$ with 10% loss.

Figure 3 shows the nuclide output rates for some high-melting elements (W, Ta and Ir) calculated using formula (12) at $th(\alpha) = 1$. Calculations were done assuming: $\beta_i = 0.05$, $D = 10^{-9} \text{ m}^2\cdot\text{s}^{-1}$, $S_i = 2 \text{ cm}^2$, $G = 32 \mu\text{A}/\text{m}^2$, $\delta = 1 \text{ mm}$. As one can see, the output rates

Table 2. Critical λ and $t_{1/2}$ values in dependence on target thickness δ

$th(\alpha)$	δ (mm)	λ (s^{-1})	$t_{1/2}$ (s)
1	10	1.1×10^{-7}	6.3×10^6 (7.3 d)
	1	1.1×10^{-5}	6.3×10^4 (7.15 h)
	0.1	1.1×10^{-3}	6.3×10^2 (10.5 m)
	0.01	1.1×10^{-1}	6.3
	0.001	11.22	6.3×10^{-2}
0.9	10	9×10^{-9}	7.7×10^7 (2.48 y)
	1	9×10^{-7}	7.7×10^5 (8.9 d)
	0.1	9×10^{-5}	7.7×10^3 (2.1 h)
	0.01	9×10^{-2}	7.7×10^1 (1.3 m)
	0.001	9×10^{-1}	7.7×10^{-1}

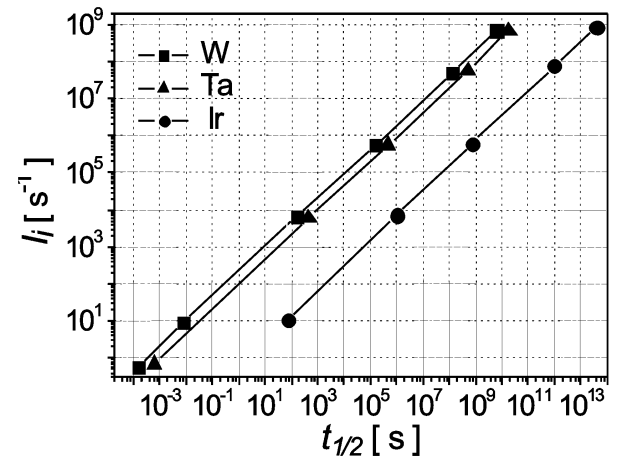

Fig. 3. Nuclide output rates for some high-melting elements.

diminish rapidly with decreasing nuclide half-life time, reaching values of ~ 10 ions per second for $t_{1/2}$ of the order of 0.1 s.

Conclusions

The described electron beam generated plasma ion source is a promising tool enabling studies that require ions of refractory elements.

The advantage of the described ion source, in comparison with other plasma ion sources, relies mainly on the formation of the potential trap inside the plasma volume.

On the basis of the critical conditions for maintaining the potential trap and physical properties of tungsten as a material the cathode and chamber walls are made of, working temperature of the ion source is estimated to be in the range 2600–2800 K. This temperature level determines the efficiency of nuclide ions production of refractory elements. This efficiency mainly depends on their half-life times.

The expected ionization efficiency of the refractory metals like Be, Ti, V, Zr, Nb, Mo, Tc, Ru, Rh, Hf, Ta, W, Re, Os, Ir, Pt is, according to our estimations, in the range 2–5%. Moreover, production of ions of isotopes with half-life times down to 1 min within a minute range is still quite feasible.

Having in mind technical difficulties concerning the on-line working mode of the ion source, using thin targets made of oxides or carbides should be consid-

ered. In the off-line mode, it seems to be necessary to use samples containing non-volatile components of the elements to be ionized.

Acknowledgment. M.T. and K.P. kindly acknowledge the support from the Polish Ministry of Science and Higher Education, Grant no. N N515 246637.

References

- Afanasev VP (1979) Alpha decay of short-lived rare earth's isotopes. Preprint LINP-532 (in Russian)
- Afanasev VP, Obukhov VA (1978) Emission of radioactive nuclei from the target of a surface ionization source during on-line operation of mass separator. Preprint JINR Dubna P13-11698 (in Russian)
- Alton GD, Liu Y, Stracener DW (2006) High-efficiency target ion sources for radioactive ion beam generation. *Rev Sci Instrum* 77:03A711–03A715
- Arlt R, Bystrov VA, Harenicht W *et al.* (1972) Isobars from the spallation reaction for nuclear spectroscopy. *Nucl Instrum Methods* 102:253–256
- Beyer GJ, Herrmann E, Piotrowski A *et al.* (1971) A new method for rare-earth isotope separation. *Nucl Instrum Methods* 96:437–439
- Bricault P, Ames F, Achtzehn T *et al.* (2008) An overview on TRIUMF's developments on ion source for radioactive beams. *Rev Sci Instrum* 79:02A908–02A912
- Cheikh Mhamed M, Lau C, Essabaa S (2008) Two-dimensional/three-dimensional simulations for the optimization of an electron-beam-generated-plasma-based-type ion source. *Rev Sci Instrum* 79:02B911–02B913
- Dushman S (1962) *Scientific Foundation of Vacuum Technique*. John Wiley & Sons, New York
- Ehrlich G, Kirk C (1968) Binding and field desorption of individual tungsten atoms. *J Chem Phys* 48:1465–1470
- Eléon C, Jardin P, Gaubert G *et al.* (2008) Development of a surface ionization source for the production of radioactive alkali ion beams in SPIRAL. *Nucl Instrum Methods B* 266:4362–4367
- Gromov KY, Kalinnikov VG, Tsupko-Sitnikov VM (1987) ISOL – facility YASNAPP-2. *AIP Conf Proc* 164:853–856
- Huysse M (1983) Ionization in a hot cavity. *Nucl Instrum Methods* 215:1–5
- Kirchner R (1990) On the thermoionization in hot cavities. *Nucl Instrum Methods A* 292:203–205
- Koizumi M, Osa A, Oshima *et al.* (2003) A laser ion source with a thin ohmic-heating ionizer for the TIARA-ISOL. *Nucl Instrum Methods B* 204:359–362
- Latuszyński A, Pyszniak K, Drożdźiel A *et al.* (2007) Atom ionization process in the thermoionization ion source. *Vacuum* 81:1150–1153
- Latuszyński A, Zuber K, Zuber J *et al.* (1974) Method of electromagnetic separation of radioactive isotopes of rare-earth elements directly from targets. *Nucl Instrum Methods* 120:321–328
- Lau C, Cheikh Mhamed M, Essabaa S (2008) Status of ionization by radial electron neat adaptation ion source research and development for SPIRAL2 and EURISOL-DS. *Rev Sci Instrum* 79:02A903–02A905
- Menna M, Catherall R, Lettry J *et al.* (2008) R&D for the development of negative ion beams of halogens. *Nucl Instrum Methods B* 266:4391–4393
- Mustapha B, Nolen JA (2004) Simulations of effusion from ISOL target/ion source systems. *Nucl Instrum Methods A* 521:59–64
- Nitschke JM (1985) An electron-beam-generated-plasma ion source for on-line isotope separation. *Nucl Instrum Methods A* 236:1–16
- Obukhov VA, Raiko VI (1986) Production of ions of short-lived isotopes. *Atom Energy* 60:139–146
- Osa A, Ichikawa S, Matsuda M *et al.* (2008) Ion source development for the on-line isotope separator at JAEA. *Nucl Instrum Methods B* 266:4394–4398
- Pantelev VN (2004) Recent ion source developments for production of radioactive beams. *Rev Sci Instrum* 75:1602–1606
- Shmor PW (2002) Ion sources for radioactive ion beams in ISOL facilities. *Rev Sci Instrum* 73:707–710
- Sokol'skaya IA, Zubenko YV (1966) Studies of gold adsorption on tungsten surface at the electron microscope with field emission. *Proc USSR Academy of Sciences, Physics Series* 30:1921–1929 (in Russian)
- Table of Periodic Properties of the Elements (1968) Sargent-Welch Scientific Co, Skokie, Illinois, USA (Catalog no. S-18806)
- Turek M, Pyszniak K, Drożdźiel A *et al.* (2008) Ionization efficiency calculations for cavity thermoionization ion source. *Vacuum* 82:1103–1106
- Turek M, Pyszniak K, Drożdźiel A (2009) Influence of electron impact ionization on the efficiency of thermoemission ion source. *Vacuum* 83:S260–S263
- Zhang Y, Alton GD (2005) Monte-Carlo simulation of complex vapor-transport systems for RIB applications. *Nucl Instrum Methods B* 241:947–952
- Zubenko YV, Sokol'skaya IA (1962) Field emission of electrons from Au-Ba. *Radiotechnics and Electronics* 7:1467–1473 (in Russian)