

APPLICATION OF FINITE ELEMENTS METHOD IN THE DESIGN OF ROAD LOCATED IN THE DENSELY BUILT-UP RESIDENTIAL AREA

Jarosław Bednarz, Grzegorz Brożek, Jan Targosz

AGH University of Science and Technology
Faculty of Mechanical Engineering and Robotics
Department of Robotics and Mechatronics
Mickiewicza Av. 30, 30-059 Krakow, Poland
tel.: +48 12 617-31-16, fax: +48 12 634-35-05
e-mail: bednarz@agh.edu.pl, gbrozek@ec-e.pl, jantargosz@interia.pl

Abstract

Nowadays, many of the designed roads are located through the densely built-up residential areas, and even the areas where there are historic buildings. Therefore, already at the stage of preliminary road design one should take into account the effects of vibration wave propagation caused by movement of vehicles on buildings located in the immediate vicinity of designed road. One of the methods that can be used to determine the dynamic effects of designed road for residential buildings is the finite element method. This paper presents an application of the finite element method for the estimation of the dynamic interaction of designed road located in the centre of a major city in the nearby residential buildings. Finite element method was used to model the land and buildings located near the designed road. In the process of land modelling the geological studies of ground and measurements of soil vibrations caused by the vibratory road roller rides conducted by the authors were used. Thus, it was possible to tune the developed finite element model. Proposed in this paper method of analysis of ground vibrations reduce the time needed to design a vibration isolating elements that will protect people and buildings from the destructive effects of vibration caused by vehicles movement the designed road. The work was carried out in a research project 4875/B/TO2/2010/38 financed by Ministry of Science and Higher Education.

Keywords: finite elements method, propagation of vibration wave in the soil, road design

1. Introduction

This paper presents analysis of propagation of vibration wave excited by the movement of vibrating roller in the soil on which is planned to build a new road. To determine the amplitude of vibration the finite elements method (FEM) was used. The analysis uses the results of measurements of vibration acceleration amplitudes done by employees of the Department of Robotics and Mechatronics AGH during the works on government research project 4875/B/TO2/2010/38 and the results of drilling carried out to identify the composition of the soil at the planned place of foundation building.

2. Description of measurements

The impact assessment of vibration waveform a newly designed road on the environment and residential buildings in one of the major Polish cities was the main purpose of research. Because the road is still being built in order to extract ground vibration a vibrating roller was used (Fig. 1) with adjustable excitation frequency up to 38 Hz and adjustable excitation force up to 15 kN.

The vibrating roller task was to excite vibrations on the measuring cross-sections on the route of the planned investment. In some cases, for purpose of gathering more dynamic information, vibrating roller was raided between the route of planned investment and residential buildings.

The scope of study included measurements of the effective value of the acceleration in the axes x and y in frequency range from 0.5 Hz to 100 Hz and in z axis in frequency range from 1 Hz to 100 Hz rectangular coordinate system of the existing buildings.



Fig. 1. A photo of a vibrating roller during its rides at the times measurements

Vibration tests were carried out in seven measuring cross-sections. In each section, the amplitude of vibration acceleration was measured in the ground at several points at different distances from the road on which vibratory roller was raised and on the foundation of existing buildings. Sometimes measurements were also carried out inside the buildings. The measuring time at each point was 180 s.

Because of the measurements, we determined the maximum value of the acceleration, which were used to tune the numerical model of land and buildings.

2. Description of numerical analysis

Numerical analysis of vibration wave's propagation was carried out with use of using the explicit finite element method [1, 4, 5]. This method is widely used for the analysis of transient phenomena such as the analysis of collisions or explosions. In the present case provides an accurate way to map the way the wave vibration induced by any coercion, and identifies a range of sizes, such as acceleration or velocity at any point in the numerical model as well as the nature of vibration transfer mechanism (Rayleigh wave or some other mechanism).

The main purpose of the analysis is to show the possibility of the use of numerical methods for the verification of solutions of wave's propagation in the soil and its dynamic effects influence on buildings. The correct representation of this phenomenon requires the construction of accurate numerical model, which requires very accurate material data and the accurate mapping of a specific area in which there is propagation of the wave as well as the correlation of results from experimental research. A properly constructed model allows to study the behaviour of such a building at different excitation (different frequency and amplitude of the signal) or for example, examine the impact of vibration isolating material to reduce vibration without the need for lengthy and costly experiments.

Numerical model built for this purpose has a size cover an area of 114 m x 72 m x 14 m approximate the situation on one of the measurement section near a single-family house. The model consisted of two layers of soil found in the area identified based on geological measurements and a simplified model of a concrete building with a basement. In the centre of the model was placed point excitation sinusoidal signal with a frequency of 33 Hz and amplitude force 15 kN simulating a vibration wave coming from a vibration roller. At a distance of 3 m, 5 m, 7 m, 15 m and at two points in the building - one at the foundation and one of the room - the amplitude of acceleration was measured in three perpendicular directions. In Fig. 2 and 3 details of a numerical model of the visible measuring points are shown.

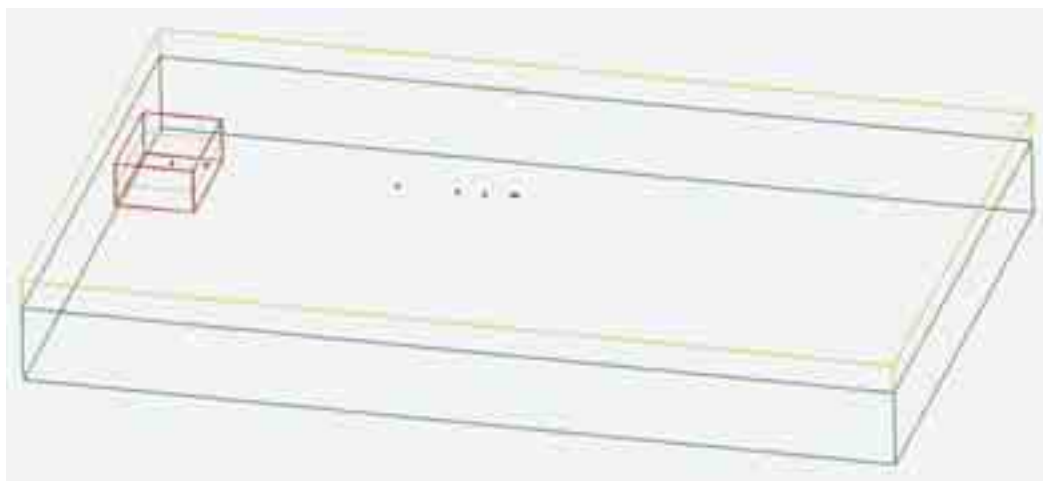

Fig. 2. View of numerical model with visible point of data record and point of excitation

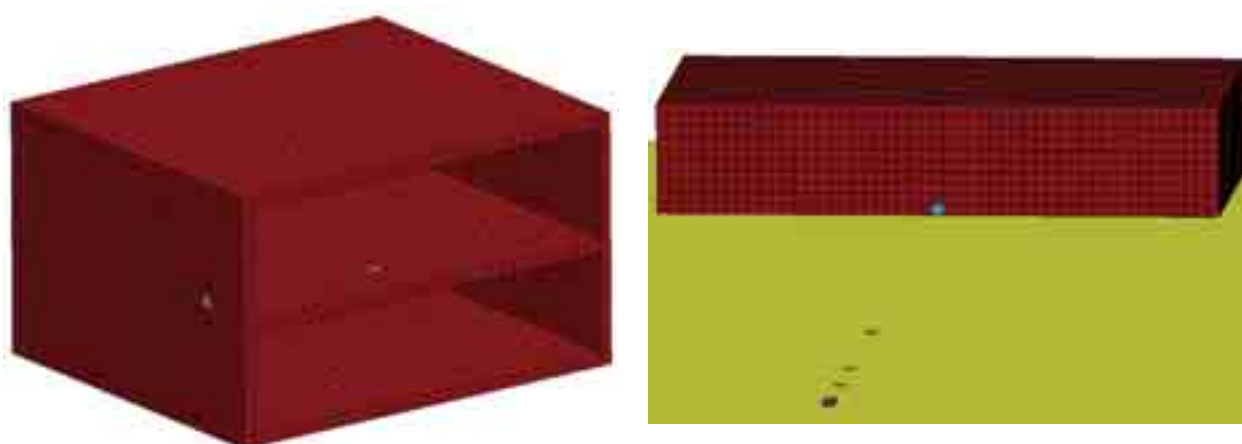

Fig. 3. Details of numerical model of a building with the measuring points (blue ones)

Due to the limited size of the model is very important to use one of the built-in mechanisms to allow the software used to prevent the wave reflected from the surface of the extreme limit the numerical model [7]. One of the most important aspects is the modelling of materials, in particular, modelling the behaviour of the soil, which is chiefly responsible for propagating wave and its damping. In this case Drucker-Prager material model [3] was used, which is widely used in numerical methods for simulating the behaviour of different soil types. In addition, the material prepared for the land allowed using them directly in the material model used. Both concrete (building) and steel (plate forcing) were included with isotropic material model. Significant impact on the quality of the analysis is accepted model for vibration damping. Rayleigh damping was used as described by the formula: $C = \alpha M + \beta K$, where C is a symmetric matrix attenuation [M] mass matrix, [K] stiffness matrix. The coefficients α and β are determined for the material based on literature data and the use of modal damping. The model consists of 4.3 million finite elements in the shape of a cube. Element size was set at 300 mm. This value results from the maximum frequency for which the results are analyzed and amounted to 100 Hz due to the experimental verification of analytical results that show the greatest force in the 33 Hz frequency (excitation frequency) and 66Hz (second harmonic of excitation signal). For the adopted set a minimum frequency of 100 Hz wavelength propagated in the centre (based on the stiffness and density of the medium) and 10 finite elements was adopted at a wavelength (3 m to the ground) for the correct mapping of a sinusoidal waveform. Numerical analysis was performed on a PC with 8 Intel Xeon class processors and took about 24 hours for the event with duration of 1s. Analysis of longer duration require a proportionately greater time, but for the numerical analysis show the possibility

of such a time was sufficient and included the moment of reaching the wave vibration to the building. The adopted time step is $1.25 \cdot 10^{-5}$, which corresponds to 80 kHz sampling rate and is fixed in program based on the highest speed of the wave at any facility used in the model and based on the dimensions of the smallest finite element used in the model. This approach results from the mathematical approach to solving algebraic equations and provides adequate stability for solutions. The results shows how the spread of the wave vibration and the nature of this phenomenon (Fig. 4). Results of analysis fully confirmed the applicability of the numerical modelling of wave propagation as a tool vibration, which significantly helps to speed up and verify the design work associated with this type of phenomena.

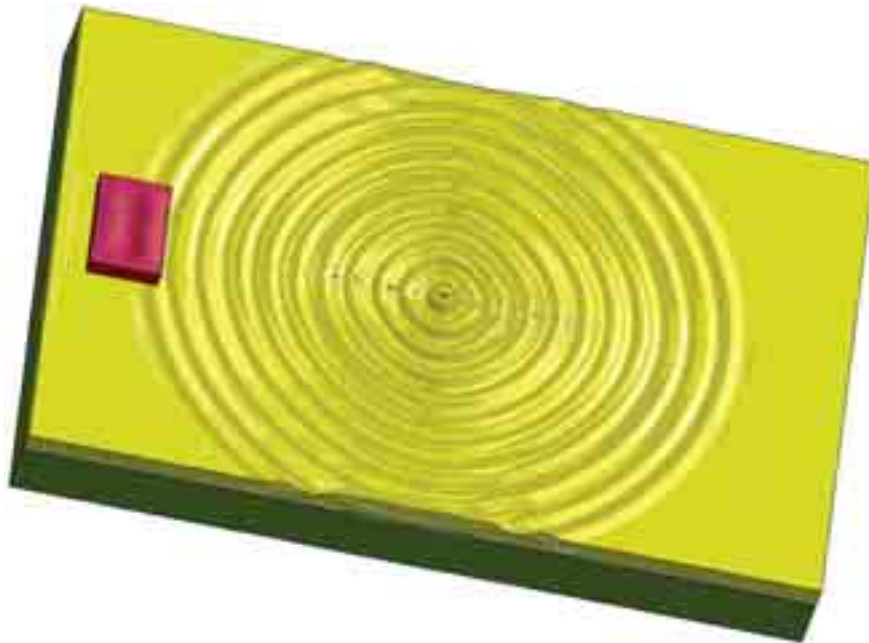

Fig. 4. View of the shape and nature of the wave vibration over time 0.3s from the first excitation (deformation scaled by a factor 50000)

3. Principles of environmental protection from vibration

The technical solutions protecting buildings from vibrations, which are, relate directly to the road and its surroundings can be distinguished essentially into three methods [2]:

1. vibration isolation of the road,
2. use of the anti-vibration screens,
3. buildings with built-in anti-vibration protections.

More than 30 - years of experience showed that one of the most effective methods of reducing vibration is to use antivibration systems. The effectiveness of such systems is determined by the ratio of vibration amplitude (displacement, velocity, or acceleration) before and after using vibration isolation, which can reach over 80%. The use of the vibration isolation of the roads is fully justified. In the seventies in the Institute of Mechanics and Vibroacoustics AGH, the studies on the problem of reducing the dynamic interactions of motor vehicles and trains were undertaken. Based on developed theoretical models the experimental and theoretical study on vibration isolation materials was conducted. For an approximate analysis we take into account the simply models of road (Fig. 5) and determine only the frequency of oscillations [6].

Vibration isolation element in our model is the rubber plate with continuous distribution of mass, which is regarded in model as a longitudinally vibrating rod. In the vibration isolation system of roads (Fig. 5) mass m_p is the mass of the platen (so-called inertial platen), and coefficient k_g is the stiffness of constant-weight distribution element (rubber plate).

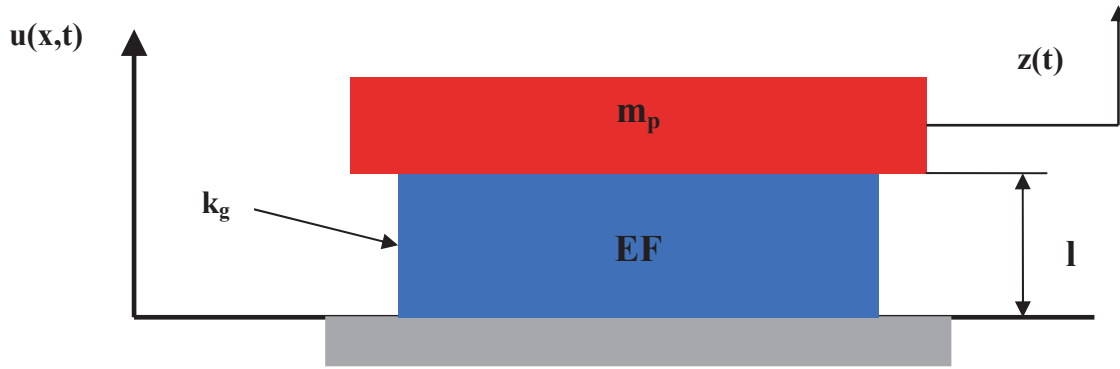

Fig. 5. Model of vibroisolated object

Vibration isolation of the road results in significant reduction of dynamic impact of traffic coming to the substrate, and thus to it increase its lifespan and significantly less subsidence in the ground path while ensuring continuity of transit transport. The theoretical research on minimizing vibration isolation should be distinguished from the effects of dynamic environment at low frequency $f < 50$ Hz and isolation of components due to the high-frequency vibrations in materials known as acoustic isolation, which is not the subject of this work. We have two types of vibration isolation: force and displacement. The first concerns the limitations of dynamic influence on the substrate, the second is intended to reduce vibration transmitted from the ground to object. In the case of machinery and transport equipment, we have in principle to deal with force vibration isolation. The condition for proper operation of vibration isolation system is to fulfil the condition:

$$\frac{f}{f_0} = \sqrt{2}, \quad (1)$$

where:

f – excitation frequency,

f_0 – natural frequency.

The condition (1) is not always feasible because the mechanical system, which is vibroisolated can be exposed to multiple resonances. Hence, it is necessary to weaken the condition of vibration isolation:

$$f_{0i} < f_w < f_{0(i+1)}, \quad i = 1, 2, \dots, 6. \quad (2)$$

This means that the frequency of excitation should be contained within the range bounded by two consecutive natural frequencies. If the mass of the vibration isolation element is significant, as is the case of machinery and transport equipment, where the geometrical elements of the vibration isolation, assimilated to a belt or a sheet modelling of vibration isolation system as a discrete system carries certain risks. The most important of these is the phenomenon of elastic wave elements because you can no longer assume that these elements are massless. In such a flexible element may appear so. internal resonances, which can cause the effect of isolation would be counterproductive, i.e. reduction of dynamic impact on the environment. To prevent this possibility, it is necessary to determine the natural frequency of vibration isolation element based on consideration of the vibration isolation system as a model of continuous or discrete-continuous. The differential equation describing this model takes the following form:

$$\frac{\partial^2 u}{\partial t^2} = a^2 \frac{\partial^2 y}{\partial x^2}, \quad (3)$$

where:

$$a = \sqrt{\frac{E}{\rho}},$$

E – dynamic Young modulus,

ρ – density of the rubber material.

Using the Fourier method of separation of variables, we obtain the equation for the frequency of the initial-boundary problem of the form:

$$\tan \frac{\omega}{a} l - \frac{EF}{m_z a \omega} = 0, \quad (4)$$

where:

$$a = \sqrt{\frac{E}{\rho}},$$

E – dynamic Young modulus,

ρ – density of the rubber material,

F – cross-sectional area of rubber,

m_z – platen mass.

On the basis of this dependence, we determine ω_i - natural frequency of road vibration isolation system. After substituting the actual value, we can choose the natural frequencies of the element of vibration isolation system and the mass of the concrete platen, so that they do not coincide with excitation frequencies. For example, we show the calculations of vibration isolation system consisting of a rubber element with a thickness of 0.4 meters and manhole cover. Fig. 6 shows a chart based on which a natural frequencies of vibration isolation system were chosen.

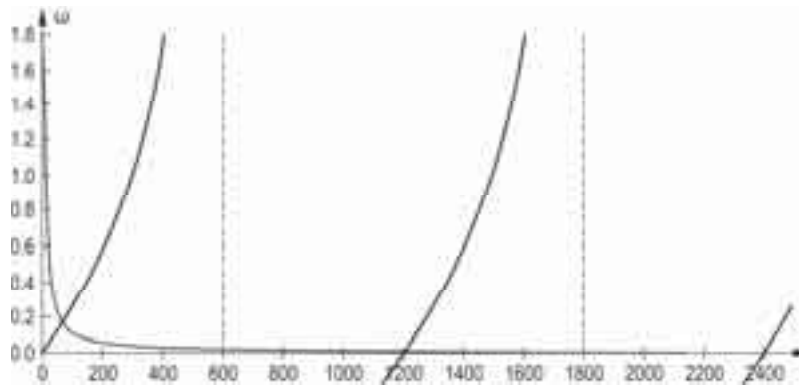

Fig. 6. Estimation of natural frequencies

The first three natural frequencies of vibration isolation system own are $f_1 = 9.39$ Hz, $f_2 = 191$ Hz and $f_3 = 382$ Hz. The only drawback to this approach is the cost of making a section of road, which could raise up to twice the cost of performance of traditional ways. Fig. 7 shows the perforated elastomeric plate, which can be, used as a rubber vibration isolation component and in Fig. 8 the idea of vibration isolation of road.

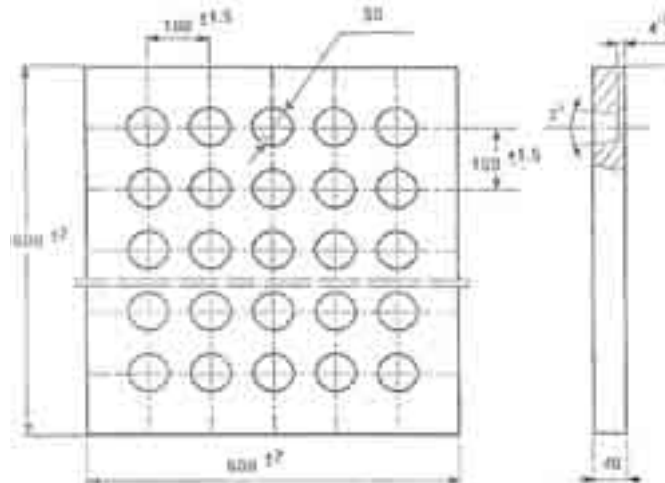

Fig. 7. Elastomeric vibration isolation plate

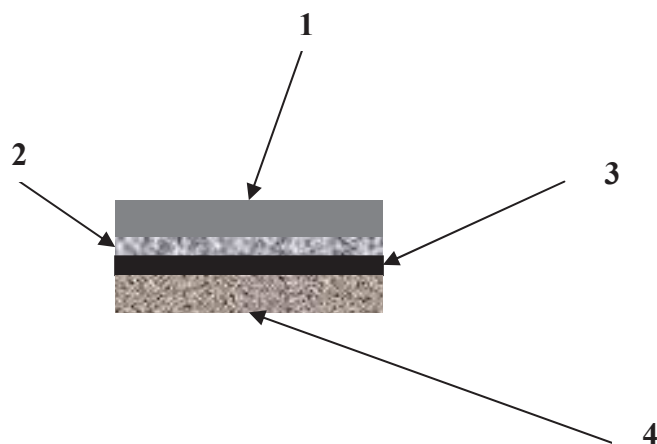

Fig. 8. Scheme of vibroisolated road

The individual layers of the road include:

1. paved road surface (4)
2. bottom concrete slab or foundation levelling of asphalt (3),
3. perforated rubber sheets which are vibration isolation system (2),
4. road (1) which is also the inertial mass.

The second method of limiting the propagation of vibrations from road communication is the use of antivibration screens. Application of antivibration screens can be divided into two types:

1. active isolation (isolation at the source of vibrations)
2. passive isolation (away from the source and closer to the isolated object).

The main target of active vibration isolation is to reduce the emitted vibrations from the source to the outside (Fig. 9). In the passive insulation (Fig. 10) anti vibrations screens are placed a baffle spaced from the vibration source and closer to the point where the vibration amplitude should be reduced. The effectiveness of the active isolation is the best when a source of vibration is surrounded by an aperture. This solution is virtually impossible in the case of vibrations from road transport, since the sources are moving, and they are not spotlights. Therefore, in practical applications the passive insulation is commonly used.

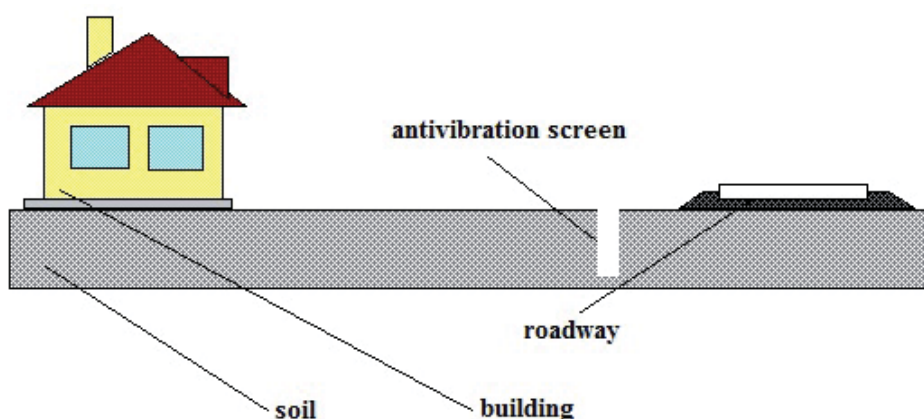

Fig. 9. Active vibration isolation

Passive isolation is most effective when the ratio of slot depth H to the vibrations wavelength λ is between 1.2 to 1.5. For example, assuming that the velocity of the wave is 200 m/s and the wavelength at the frequency $f = 10$ Hz is $\lambda = 20$ m, the depth of the gap for effective insulation should be 24 to 30 m so we can see that also in many cases possibility of passive slots application is limited.

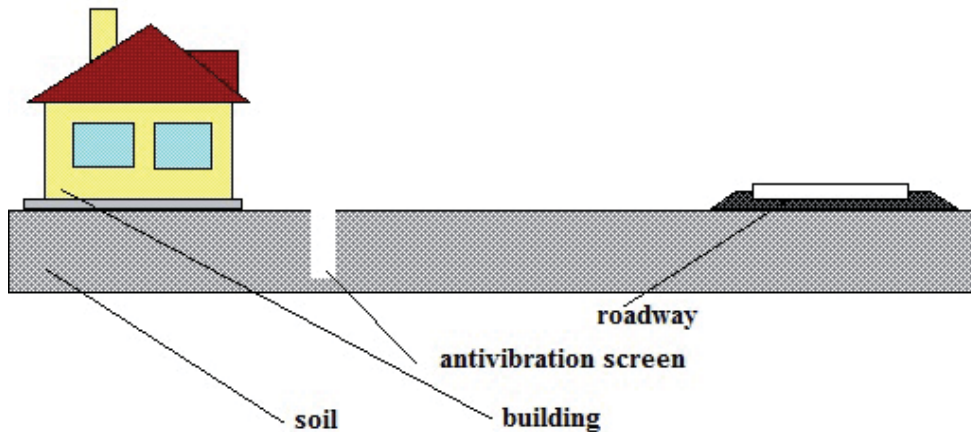

Fig. 10. Passive vibration isolation

The technical solutions for protection of buildings from vibrations caused by road and rail traffic can be classified as follows:

1. proper selection of buildings material at the design stage including:
 - a) selecting construction material with the most favourable dynamic parameters such as stiffness, damping, mass, to reduce the possibility of structures resonances,
 - b) application of elastic materials,
 - c) introduction of vibration isolation elements into construction of the building,
2. application of passive insulation system to protect the whole building from the impact assessment of vibration,
3. application of vibration isolation between the foundation and the building by using the springy, rubber or polyurethane absorbers,
4. isolation rooms inside buildings by so called. "floating floor".

The most effective way to prevent the building structure vibrations from the environment is to take into account the possible vibration source already at the design stage. Based on the knowledge of seismic conditions (vibration caused by seismic shock) or paraseismic (vibration caused by road and rail traffic) ones can so modify the design of building that the probability of resonance states of construction is minimized. In Fig. 11 and 12 some building structures modification methods at the design stage are presented. In Fig. 11a model of a building structure with modification of the stiffness and mass is presented. In the Fig. 11b the idea of damper application is presented.

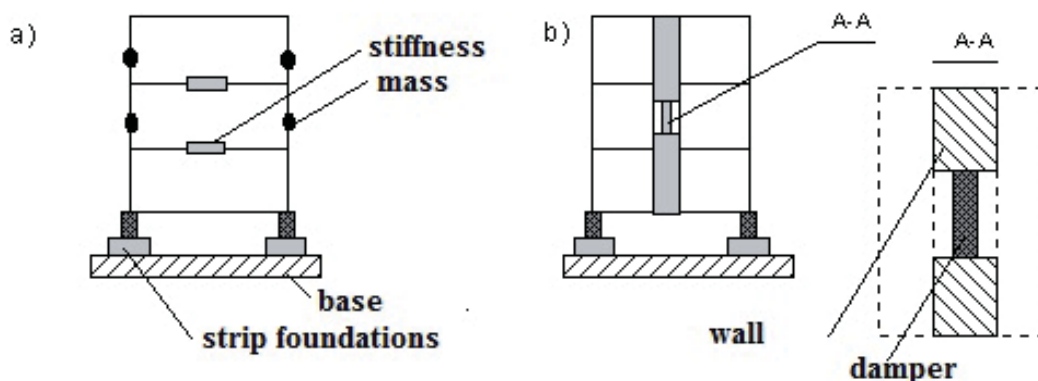

Fig. 11. Methods modifying the structure of buildings

In Fig. 12a the frame structure that uses elastic joints is presented. In Fig. 12b a diagram of the foundation with four absorbers built-in is presented. The absorbers assume the role of mid-frequency filter.

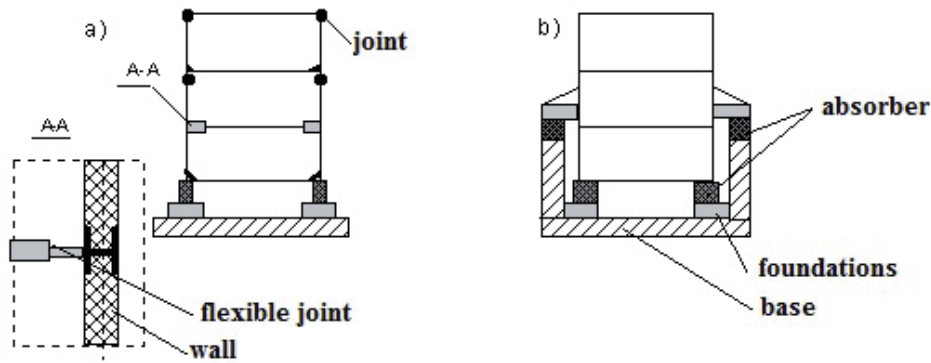

Fig. 12. Example of structures with flexible joints

In the Fig. 13 the concepts of foundation of loose lower tier, which are often used in the USA, is presented. This technical conception base depends on foundation bearing basins, which can move in limited range by application of the elastic dampers.

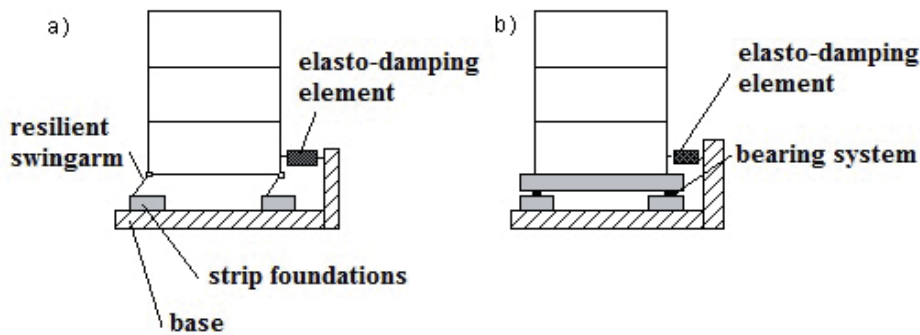

Fig. 13. Building placed on a flexible element

In Fig. 14 the diagrams of active vibration isolation systems are presented. These solutions are often used in areas threatened by earthquakes i.e. in Japan and USA. The system control the stiffness and damping parameters of the vibration absorber based on signal from the vibration sensor.

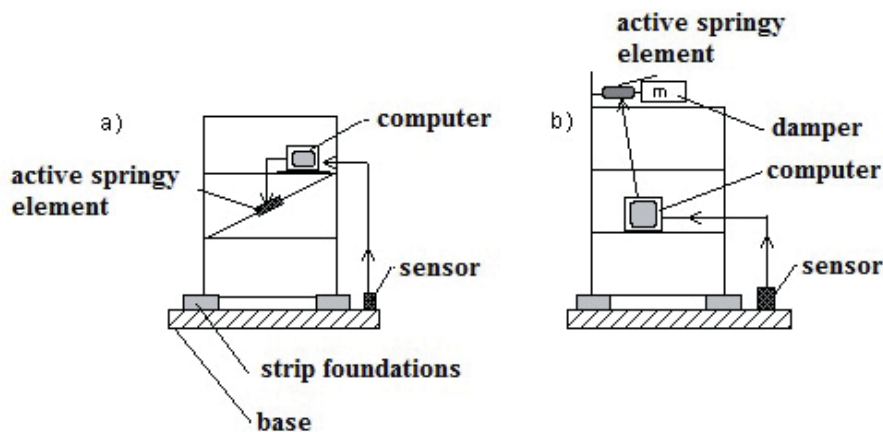

Fig. 14. Active vibration isolation of building

If a building already exists and seismic conditions or traffic on existing road have changed the vibration isolation can be used between the foundation and structural walls. In Fig. 15 the idea of building vibration isolation base on elastomeric elements between foundations and structural walls is presented.

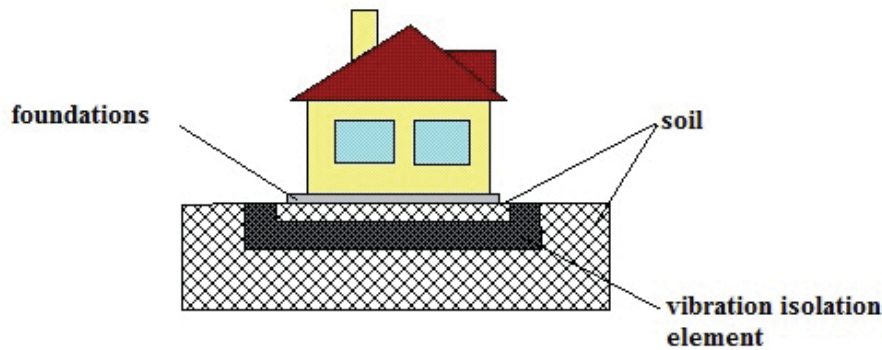

Fig. 15. Concept of building vibration isolation

To reduce the impact of vibration cause by moving vehicles for people living in buildings and equipment in manufacturing plants the so-called “floating floor” technique can be used (Fig. 16).

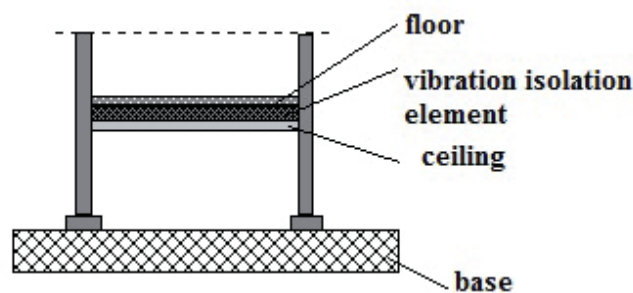

Fig. 16. Concept of so-called “floating floor”

Between the ceiling and the floor-selected vibration isolation system, such as a perforated rubber plate (Fig. 7) dissipates the energy of vibration transmitted from the ground and reduces the amplitude of a vibration impact on the people residing on the premises.

4. Conclusion

Conducted vibration measurements and analysis carried out confirmed the prognostic evaluation based on simulation of vibration spreads into the environment. Hence the observation that at the design stage of a new road must first be carried out and then you can greatly reduce the amount of measurements. It should be also noted that the type of force adopted, with such a high dynamic force will not occur in the real world, even in the case of heavy traffic and load. However, in order to protect residential buildings the solutions presented in chapter 3 of this paper should be applied. Experience has shown that vertical antivibration screens do not always are the best solution, we propose to apply horizontal vibration isolated road on certain sections of this investment. Proper selection physico-mechanical properties such as stiffness, damping, durability, hardness parameters, of available vibration isolation materials have to be made by experienced team.

References

- [1] Bednarz, J, Targosz, J., *Finite elements method in analysis of propagation of vibrations wave in the soil*, Journal of KONES Powertrain and Transport, Warsaw 2011.
- [2] Ciesielski, R., Maciag, E., *Drgania drogowe i ich wpływ na budynki*, WKŁ, Warszawa 1990.
- [3] Drucker, D. C., Prager, W., *Soil mechanics and plastic analysis for limit design*, Quarterly of Applied Mathematics, Vol. 10, No. 2, pp. 157–165, 1952.

- [4] Gerolymos, N, Gazetas, G., *Static and dynamic response of massive caisson foundations with soil and interface nonlinearities-validation and results*, Soil Dynamics and Earthquake Engineering, Vol. 26, pp. 377-394, 2006.
- [5] Hassen, G, de Buhan, P, Abdelkrim, M., *Finite element implementation of a homogenized constitutive law for stone column-reinforced foundation soils, with application to the design of structures*, Computers and Geotechnics, Vol. 37, pp. 40-49, 2010.
- [6] Lipiński, J., *Fundamenty pod maszyny*, Wydawnictwo Arkady, Warszawa 1985.
- [7] Mulliken, J. S., Karabalis, D. L., *Discrete models for through-soil coupling of foundations and structures*, Earthquake Engineering Structural Dynamics, Vol. 27, pp. 687–710, 1998.