

# NUMERICAL ANALYSIS OF THE SCREW CONNECTION WITH PRELOAD TENSION USED IN THE MOUNTING OF SLEWING BEARINGS

Piotr Reszka, Ludwik Kania, Rafał Pytlarz

Technical University of Czestochowa  
Department of Mechanical Engineering and Computer  
Dąbrowskiego Street 73, 42-200 Czestochowa, Poland  
tel.: tel. +48 34 325-06-20, fax: +48 34 325-06-47  
e-mail: reszka@imipkm.pcz.p  
ludwik@imipkm.pcz.pl, pytlarz@imipkm.pcz.pl

## Abstract

Slewing bearings are used as devices that connect two part working machine, usually with a rotating chassis body must meet safety criteria, manage to cope with extreme loads and environmental factors operation life. In this paper the distribution of pressure on surfaces of the screw's connections with preload tension is considered. A joining model which is used in rolling bearing is the subject of the analysis. The aim of the work is to introduce an auxiliary criterion of 'connection tightness' to the calculating methodology of bearings' fastening connections with building structure. Considered part of the three-row roller bearing, rings bearings and mounting elements are modelled solid type, and the bolts are modelled with beam-type element introduced preload tension value equivalent catalogue. Connected elements of the screw head rigid elements. The screws used in such a combined coronary bearings are not close fit, and established contact between the surfaces of the rings and the building is not homogeneous. Work is not only dedicated to the stress of contact between the contact surfaces A and B, but also considered is the effect of pitch spacing of the screws on the pitch rolling element bearing in the numerical solution ADINA system was used to prepare numerical models of junction. The results of the calculations of pressure distributions for changeable screw's span are shown graphically and the table of percentages of the load loss of contact between the surfaces A and B of slewing bearing screw connection.

**Keywords:** slewing bearings, screw connection, preload tension, FEM

## 1. Introduction

Bolt connections used in slewing bearings are the subject of the work. Bearings are elements of heavy construction machinery used in various fields of technology. Slewing bearings connect two parts of the machine: chassis structure and body. The bearing acts as a mechanism of rotation and transmit the external load from the body to the underbody structure. The bearings can be loaded by axial force  $Q$ , radial force  $H$  and tilting moment  $M$ . Fig. 1 shows slewing bearing in the structure of a working machine. The slewing bearings are selected on the basis of graphs of maximum bearing load called the characteristics of the bearing. Such characteristics determine the field of the bearing work in the form of the equation  $M = f(Q)$ .

The bearing's characteristic is determined on the basis of the limited load of rolling parts based on the established criterion. Mostly, it is the criterion of relative plastic deformations in the contact zone [1]. What is more, the bearing's load capacity depends on the load capacity of the screw junction. Bolts which fasten the bearing are assembled with the initial tension and calculated according to traditional methods of calculating this type of bolts [2]. Guidelines for the calculation of bolts are also given in the recommendations of the bearings' producers [3]. The primary criterion of the calculations is the limited stress value in the bolt while maintaining specified value of residual clamp in the zone of joined elements' deformation. However, such approach does not

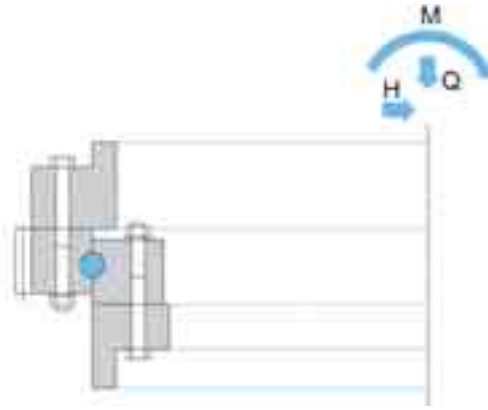

Fig. 1. The slewing bearing in structure of the machinery working

always provide the correct bearing work. As a result of the load with tilting moment bearing, rings are tearing off from buildings elements on circuit's parts. The development of computational techniques and the usage the method of finite element for modelling the bearings also changed the way of analysis of screw connections. Screws are modelled singly finite elements, in the work of [1, 4, 5] or are full of models bolt made with solid elements [6-9] whether, finally, other special ways of modelling [10].

It seems that the most effective way of modelling is the simulation of core screw with single finite element. Independently from the method of modelling bolts in slewing bearings, the ring can treat as beam supported in many ways, and the segment of the ring between each, and every bolt as a beam span. Along this span load which comes from parts of rolling works, and that load causes bending and torsion of ring. Eventually, it may lead to the loss of contact between connected elements. Rings of slewing bearing can be sectional and non-sectional. An example of the sectional rings are used in ball bearings and double row roller bearings triple row Fig. 2a. and non-sectional bearing ring is single row ball bearing Fig. 2b.

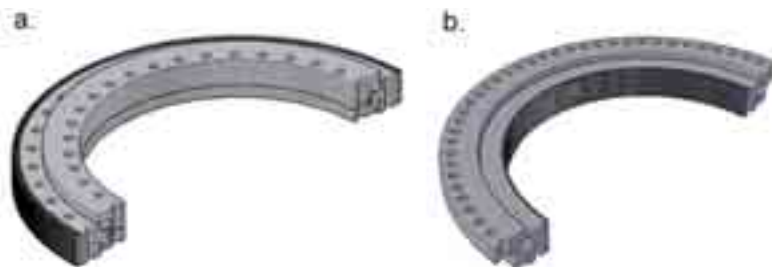

Fig. 2. Slewing bearings: a) three-row roller bearing with external gear, b) single row ball with internal gear

For bearings with sectional rings is very important not the loose the contact between the two parts of the ring. Loose of the contact increases the effective value of the clearance in the bearings. Nonetheless, that may cause operational problems with bearings, as well as loss of contact between the bearing rings and the elements of the building. The bearings with sectional rings which fasten the bearing also act as the connecting screws which join parts of bearing rings. In addition, the bearing attached to the deformable support structures is deformed by factors resulting from the design of these structures. The purpose of this paper is to analyze the influence of pitch spacing of the screws on the perimeter of the slewing bearing on the quality of junction which is understood as a contact between the joined elements spans on the entire length of the ring. On the basis of a catalogue of large rolling bearings [11] we can stated that the single row ball rolling bearings, the number of pitch of rolling elements per one pitch of screws varies from two to four, in three-row roller bearings three to four, and up to five in double-row bearings. These data is summarized in Tab. 1.

Tab. 1. The number of scales on the scale of the roller screw in selected solutions

Number of rolling elements	Screw number	The number of rolling elements on the pitch screws
Single-row ball bearing		
34	12	2.83
46	12	3.75
50	12	4.166
double-row ball bearing		
95	28	3.39
195	40	4.875
169	30	5.633
three-row roller bearing		
187	60	3.11
142	40	3.55
150	36	4.166

Therefore, it seems that the introduction of an additional criterion for selection of bolts bearing is desirable. For this purpose, in this study a preliminary analysis of the problem in the way of numerical calculations using the ADINA system was performed [12].

## 2. Tested model description

The solution of connection structure for three-row roller bearing with a diameter of 1.5 m was used for the construction of numerical models junction. This is a bearing with shared rings which has three rows of rollers. Two rows are arranged radially and transmit axial force  $Q$  and the tilting moment  $M$ , the third row of rollers is parallel to the bearing axis and transmit only the radial component of external load of bearing. The segment of the circumference of the bearing is isolated with a length of more than three pitches between the screws. To simplify the model the curvature of the ring is omitted. That allows a relatively large diameter of the bearing. The system is shown in Fig. 3. In the test metric M24 bolts in grades 8.8, 10.9 and 12.9 are used. Load capacity of the rolling elements is assumed on the basis of the permissible load:

$$\delta_{pldop}/d_w = 0.0002 . \tag{1}$$

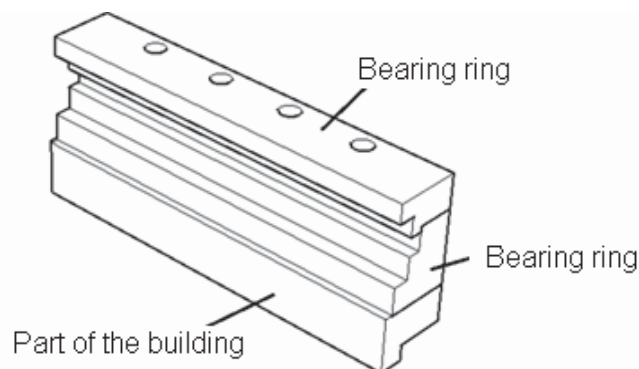

Fig. 3. The slewing bearing in structure of the machinery working

Permissible axial force for this class of bolts is given in the catalogue [3]. The load for bearing rings is carried out by concentrated forces applied in places and distributions of bearings' rollers with the limit value of 18 kN [3] (roller with a diameter of 20 mm and 18 mm active length). This is the maximum force that may be loaded, calculated on the basis of roller according to [1]:

$$P_{dop} = 123.57 f_H d l \sqrt{1 - \frac{d}{2a_0} \cos \alpha} . \quad (2)$$

A coefficient of friction with  $\mu = 0.15$  between the contact surfaces is taken into account. The appropriate preload force corresponding to the strength class is applied for each of the screws.

### 3. Numerical modelling and simulation

Numerical model of the bearing rings and the building is built with 8-node solid elements most suitable for contact problems modelling. Beam elements are used to model the rod of bolt and a group of rigid components is applied to model the bolt heads and nuts in models of screws which connect rings and shell. ADINA program provides a special type of beam elements, called bolt, which can transmit bending moments, and the application of the initial tension is possible. The nodes of beam elements should be combined with nodes of bearing rings and shell beam. For this purpose, a mechanism connecting screw nodes to rings nodes with rigid splitters simulating the bolt head was used. It is shown in Fig. 4.

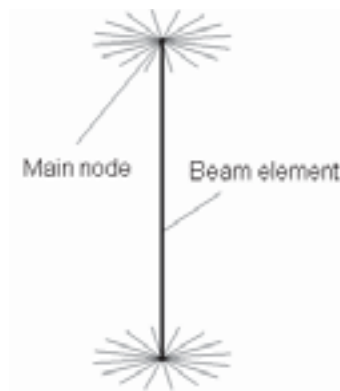

Fig. 4. Bolt model used in connection

That model sometimes is called a rigid spider web. Rigid elements are joined by one of its nodes in the centre of the rigid spider web, which is associated with two-element node beam which simulates the stem bolts. Other nodes of spider web can connect to any ring nodes and shell elements and create a rigid screw head. This is one way of modelling the bolts in the slewing bearing models. Beam elements of the bolt have related diameter of the screw corresponding to the size of the M24 screw and the choice of a cross-section of a pipe element with the full space used only in the case of beam elements is used. It is a specific way of modelling the bolts in the ADINA program. Between the surfaces of the bearing rings (surface A) and the ring and shell (surface B) appropriate contact conditions are applied. Fig. 5 shows the numerical model of the tested screw connection. The initial tension with a value of 168 kN and 200 kN and 270 kN is introduced for M24 bolts according to the strength class bolts. The forces exerted by the rollers are applied with 25 mm pitch (as in a standard bearing). The distance between the screws in the various models of the ring is from 3 to 6 load pitches. Models are called correspondingly 3, 4, 5 and 6. The calculation are made at three selected values of the initial tension for each model. Two cross-connectors (shown in Fig. 6) are selected to analyze the changes of contact conditions. All cases of bolted joints are proper due to the bond strength calculated by classical methods.

### 4. The results of calculations

Using the models of screw connection, calculations for the three classes of strength bolts are made. The results are presented in graphs and tables. In order to estimate the loss of contact on the

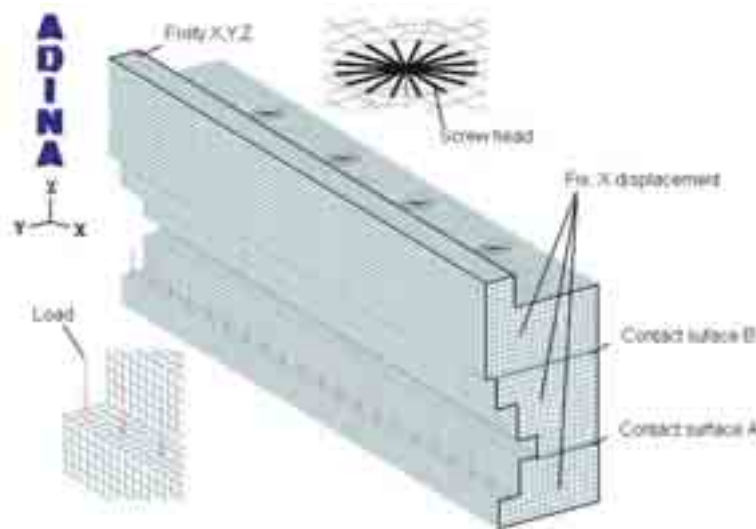

Fig. 5. Grid numerical model with boundary conditions

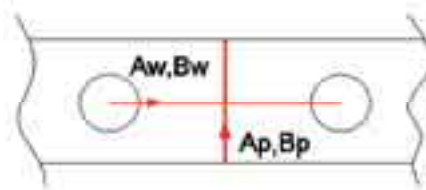

Fig. 6. The analyzed cross connector

surfaces of the bearing rings, we introduced additional cross-sections for the studied surfaces A, B. ( $A_W$ ,  $B_W$  cross – section along the study surfaces,  $A_P$ ,  $B_P$  – cross-section across the surfaces). Cross sections are indicated in Fig. 6. Fig. 7 shows an exemplary distribution of the contact stresses on the analyzed surfaces of numerical model (4-8.8) with screws located at a distance 0.1 m with 4 pitches of the rolling element and the preload tension equal in the screw 168 kN.

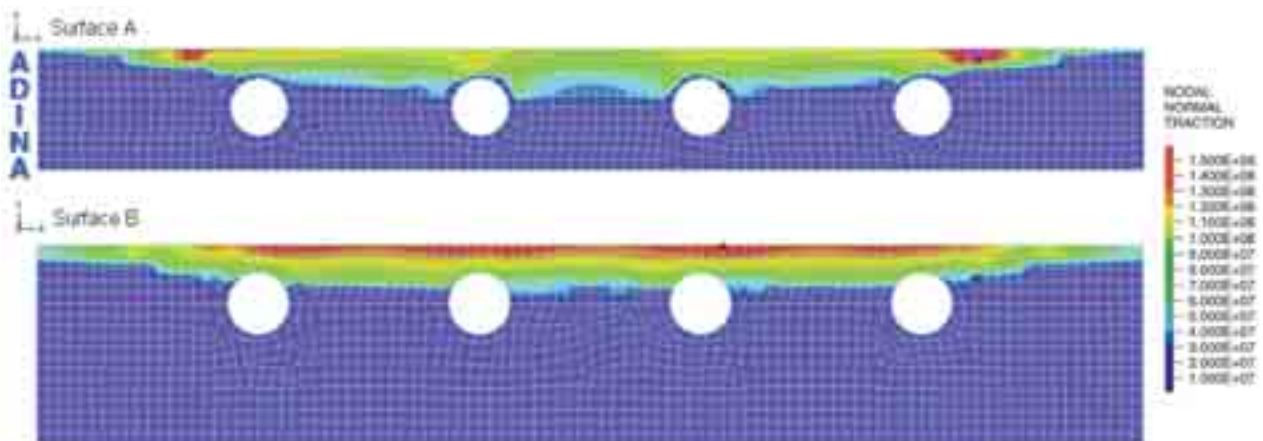

Fig. 7. The distribution of contact stresses, the surface of A and B (0.1 m bolt spacing – 4 scale load)

The graphs of bolted joints' stresses distributions in two sections: along the surface and across the surface A is given in Fig. 8 and 9. For maximum roller load equal to 18 kN total loss of contact occurs at the value of 12 kN. It is 66.6% of the maximum load for a cross-sectional surface of the roller  $A_W$  (section along the surface), for the  $A_P$  cross section (cross section across the surface), the total loss of contact stress appears after reaching 27.7% of the maximum load, there is no complete breakdown of the contact stress. In the case of surface B, the total cross-section of  $B_W$  loss of

contact stress occurs much earlier, at 55.5% of the maximum load roller, but for section B<sub>p</sub> effect of partial loss of stress appears in the moment of the initial tension introduction. In other models of the screw connection (3, 4, 5, 6) a partial loss of contact stresses also occurs for B in the cross-sectional B<sub>p</sub> during the initial tension introduction.

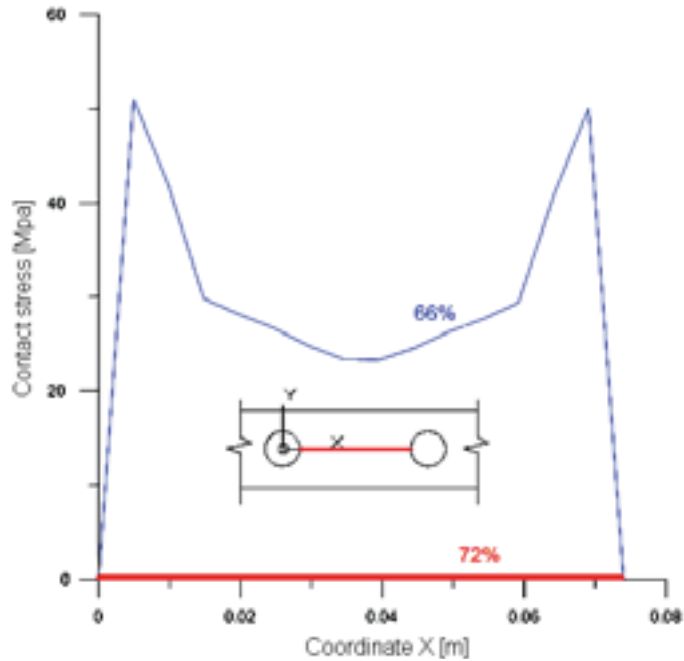

Fig. 8. The distribution of contact stresses, the surface of A and B (0.1 m bolt spacing — 4 scale load)

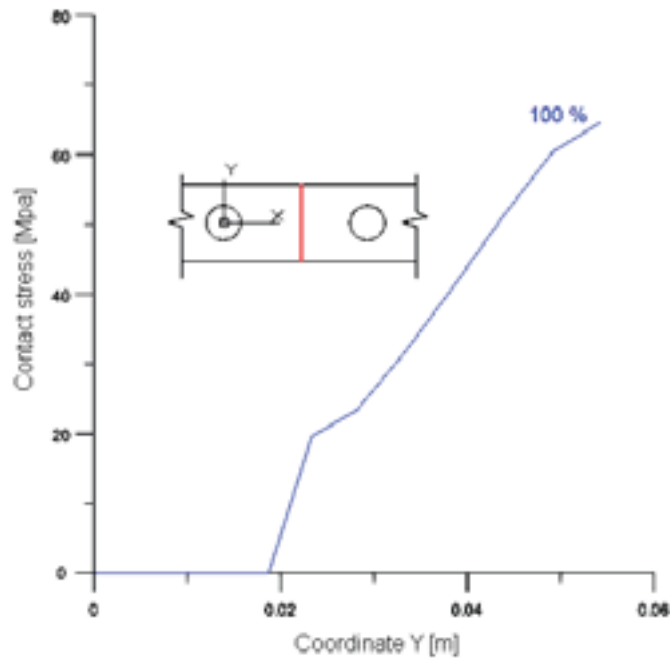

Fig. 9. The Graph contact stresses across the screw connection, the area A, class 8.8, the distance between the screws 0.1 m — 4 scale load.

In the case of a farer screws location, as in the model (5-8.8) with the same initial tension as described in the previous example, the location of screws at the distance of 0.125 and five pitches, partial loss of contact on cross-sectional surface A<sub>w</sub> occurs at 55.5% of the load roller, and when reaching 58.3% complete loss of contact stresses occurs. In comparison with the model (4-8.8), total loss of contact occurs at A<sub>w</sub> section occurs with a smaller of 8.75% load. For cross-section A<sub>p</sub>

in the model (5-8.8) a partial loss occurs for the same value of the load like in the model (4-8.8), which means 27.7% for the maximum roller load. Appropriate choice of scale is thus determined by number of rollers and the initial tension in the bolts. Comparing the results of the calculations in Tab. 2 (models 3, 4, 5, 6) can be seen that the optimal model is the model with three pitches of rolling elements, because the complete loss of contact stresses along the screw connection does not occur there. That confirms the obvious conclusion that short span of the ring beam experiences the smallest deformations. A small number of roller scales on one screw scale can sometimes lead to technological difficulties due to insufficient distance between the screws.

Tab. 2. The results of calculations on the impact of the load loss of contact between the surfaces of the analyzed connection

		Screw class					
		8.8		10.9		12.9	
		Load rollers a percentage of maximum load					
Loss of contact		P	F	P	F	P	F
Model 3	A <sub>w</sub>	91.3	91.6	—	—	—	—
	A <sub>p</sub>	89.4	—	55.5	—	66.6	—
	B <sub>w</sub>	92.7	92.7	—	—	—	—
Model 4	A <sub>w</sub>	—	66.6	72.2	77.7	95.5	98.8
	A <sub>p</sub>	27.7	—	44.4	—	44.4	—
	B <sub>w</sub>	—	55.5	—	72.7	—	88.8
Model 5	A <sub>w</sub>	55.5	58.3	55.5	72.2	77.7	94.4
	A <sub>p</sub>	27.7	—	27.7	—	27.7	—
	B <sub>w</sub>	55.5	56.1	66.6	72.2	83.3	94.4
Model 6	A <sub>w</sub>	44.4	56.6	44.4	66.6	55.5	83.3
	A <sub>p</sub>	0	—	27.7	—	27.7	—
	B <sub>w</sub>	44.4	66.6	44.4	66.6	66.6	88.9

P – partial loss of contact, F – full loss of contact

The paper contains only sample graphical results of pressure distributions along the line connecting the screws on the surface for increasing load values for two cases.

## 5. Conclusions

The results gain thanks to numerical calculations of screw connections allow to conclude that the proposed criterion of continuous contact on the bearing rings in most cases is not performed. The image of contact stresses on the surfaces of the bearing rings indicates that the criterion of the residual clamp in the area of the deformation cone in connector with the initial tension (criterion for analytic calculation of bolted connections) is also not satisfied. In the illustrated example (screws classes 10.9, screws scales four times bigger than the scale of the roller) loss of contact stresses in the cross-sectional area A<sub>w</sub> occurs at a rollers load of 12 kN, which represents 66.6% of the maximum and balanced contact surface is increasing rapidly with the increase of load. It is unacceptable situation. Therefore, it is needed to use screws or a higher class, or in this case, reduce the scale of the rolling elements (which is usually not an option) or change the distance between screws. Using bigger initial tension in the screw (higher grade of bolts) we can achieve favourable contact stress distribution on the surface, but higher initial clamp reduces the effective area of the bearing, with large values of subversive time. This is an issue that goes beyond the scope of this study and will be dealt with separately. Each of the proposed method is limited to certain conditions and construction. That is why individual cases of bearings appliance should be considered

separately. Finally, it should be noted that because of the relatively rapid loss of contact between the surfaces of the bearing rings and body, and especially between the non-sectional rings, introduce of an auxiliary criterion of “connection tightness” is desirable, at least in a partial extent.

## References

- [1] Kania, L., *Analyze of internal load of slewing bearings in respect of their load carrying capacity*, Czestochowa University of Technology Publishing, Czestochowa 2005.
- [2] Dziurski, A., Kania, L., Mazanek, E., *Calculation of bolted joints in slewing bearings*, Review of Mechanical Engineering, Vol. 61, No. 9, pp. 30-36, 2002.
- [3] *Slewing Bearings GWL\_GB*, Rothe Erde, Dortmund 2011.
- [4] Smolnicki, T., *Physical aspects of the coherence of large-scale deformation of rolling bearings and support structures*, Publishing House of Technical University of Wroclaw, Wroclaw 2002.
- [5] Smolnicki, T., Derlukiewicz, D., Stańco, M., *Evaluation of load distribution in the superstructure rotation joint of single-bucket caterpillar excavators*, Automation in Construction, Vol. 17, No. 3, pp. 218-223, 2008.
- [6] Chaib, Z., Daidié, A., Leray, D., *Screw behavior in large diameter slewing bearing assemblies: numerical and experimental analyses*, International Journal on Interactive Design and Manufacturing, Vol. 1, No. 1, pp. 21-31, 2007.
- [7] Jeong Kim, J., Yoon, J., Kang, B., *Finite element analysis and modelling of structure with bolted joints*, Applied Mathematical Modelling, Vol. 31, No. 5, pp. 895–911, 2007.
- [8] Pollicino, F., Schleeßelmann, R., *Berechnung der hochbelasteten Schraubenverbindung des Rotorblattes einer Windenergieanlage mittels FEM und VDI 2230 unter Berücksichtigung der Montage*, Germanischer Lloyd Wind Energie GMBH, Hamburg 1-25, 2005.
- [9] Göncz, P., Glodež, S., *Calculation model for pre-stressed bolted joints of slewing bearings*, Advanced Engineering, Vol. 3, No. 2, pp. 175-186, 2009.
- [10] Mazanek, E., Krynke, M., *Possibility of modelling the fastening bolts slewing bearing*, XXIII Trends in the Development of Heavy Duty Machines, Zakopane 2010.
- [11] *Łożyska toczne wielkogabarytowe, katalog-informator*, Zawierciańska Mechanical Plant „Bumar-Łabędy” S.A., Zawiercie 1997.
- [12] *ADINA, Theory and Modelling Guide*, ADINA R&D, Inc., Watertown 2011.