

DIAGNOSTIC AND MEASUREMENT SYSTEM DEDICATED FOR MARINE ENGINES' EXPLOITATORY ATTRIBUTES EVALUATION

Adam Charchalis

*Gdynia Maritime University, Faculty of Marine Engineering
Morska Street 83, 81-225 Gdynia, Poland
tel.: +48586901347, fax: +48586901399
e-mail: achar@am.gdynia.pl*

Abstract

Modern way of machines' exploitation, due to their high level of constructional complication, requires certain level of supervising. That supervising is generally reduced to detection of pre-failure states and evaluation of machines' single elements or components condition. In the frame of development of the research capacity of the Mechanical Faculty of Maritime Academy in Gdynia, has been developed the Exploitation Decision Aid System for marine engines exploitation, based on existing test bed with the marine diesel engine Sulzer AL 25/30. Modernization of the engine, significantly extended research and measurement capacity, what has resulted with improvement of quality, extension of the span, and acceleration of carried out research and development works in the domain of safety of exploitation and diagnostics of marine power plants. Above stated investments enables also an extension of the range of research and expertise related to engines' failures and exhaust gases emission pollution, in relation to broad spectrum of implemented fuels. The goal has been achieved in the way of the test equipment modernization including: effective pressure sensors, high pressure fuel sensors, monitoring and visualization of the engine systems' parameters, electronic indicators adopted to continuous operation at all cylinders in the same time, and high class decision aid computer equipment.

Keywords: *diesel engines, marine engines, engine diagnostic, exploitative attributes evaluation, pressure sensors*

1. Marine Diesel Engine Sulzer AL 25/30 test bed

Diagnostic system for evaluation of exploitation attributes of marine diesel engines consist of the diesel engine driving electric generator and top class operating station enabling monitoring and recording of working parameters. The operating station enables also remote control of the engine and auxiliaries. Diagnostic system consists of:

- three cylinders, four stroke diesel engine type 3AL 25/30 Cegielski Sulzer with power rate of 396 kW, with turbocharger type VTR 160 Brown Boveri,
- synchronous, self - excitation electro generator GD8-500-50, 500 kVA,
- operating station EMOS,
- electronic indicator with Kistler combustion sensors,
- electric switchgear,
- fan coolers,
- fuel tanks with fuel distribution system and the centrifugal.

Diesel engine

The marine diesel engine type 3 AL 25/30, is four stroke non-reversible self-ignition, turbocharged engine. The engine was manufactured by HCP Cegielski in Poznan, under licence of Sulzer.

Main technical particulars of the engine:

- type - 3AL 25/30,
- no. of cylinders - 3,
- bore [mm] - 250,

- stroke [mm] - 300,
- swept capacity [cm³] - 14726,
- power rate [kW] - 408,
- rotational speed [rpm] - 750,
- compression ratio - 1:13.

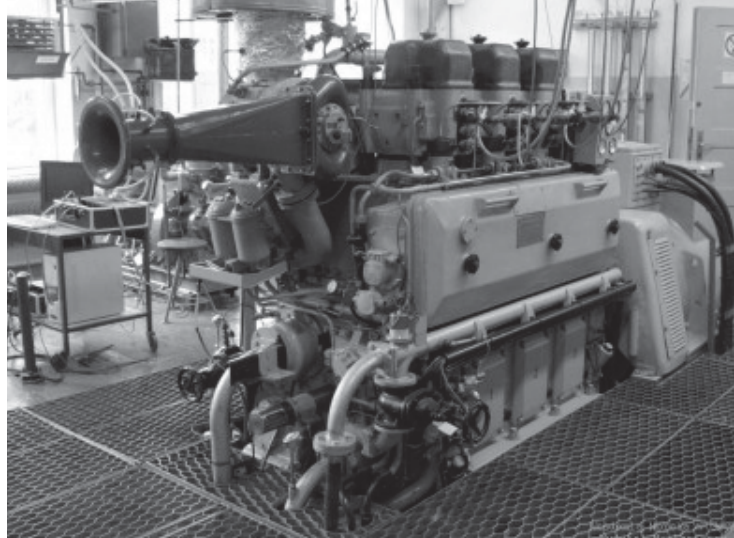

Fig. 1. Marine diesel type 3AL 25/30

Operator station EMOS

Operator station EMOS is dedicated to current control, visualization and archive of the working parameters of the engine Sulzer 3AL 25/30.

The station is equipped with personal computer with two displays (19" and 40") and operator board, consisting the set of control lights and elements of engine's systems work control. The station is also equipped with safety devices system, and system of auxiliary mechanism monitoring and steering, both are governed by PLC programmable Logic Controller) Schneider Modicon.

PLC Schneider Modicon is based on 4 basic processors, with Modbus communication, and 3 processors for integration of two within 3 communication lanes (CANopen, Ethernet and Modbus) each. Every processor has a port USB mini-B, which is the programming port and also connecting port for graphic panels Shneider Electric. The system modicon M340 is build up basing on the board enabling configuration of full spectrum of amplifiers, processors and in/out modules with "hot swap" function what means broken element exchange without switching off the system. In/out modules are: analog, digital (64 channels) and fast counters.



Fig. 2. Programmable Logic Controller Modicon M340

All parameters controlled by operator station are available for outer recorders.



Fig. 3. Operator station EMOS

The operator station fulfils tasks as follow:

- operator access to all controlled working parameters,
- constant display of alarms list with alarm on, alarm off and acknowledge time,
- acknowledgement of appearing alarms using the keyboard or the mouse,
- possibility of setting four alarm threshold levels for analog signals,
- possibility of setting time delays of alarm signals,
- changing of configuration of measurement channels, selection of measurement ranges and calibration,
- constant archiving of data and simple mode of files outlook,
- recording of trends of analog data and trends of changes based on records history,
- Data export to outer receivers for subsequent analysis and processing,
- Three access levels for different operators,
- Printing of the rapports and data sets,
- Independent work of two monitors enabling display of two pictures in the same time.

In the case of occurring the alarm, EMOS system initiates visual alarm in the form of a blinking light and a horn acoustic signal. The alarm initiation delay can be set on individual determined for every alarm channel.

For measurement, depending of range, were used transducers EMT-101-PT100 or TCH-3212-PT100. Measurements of pressure value were proceeded using transducers ECOS or NA-10A.

Stationary Cylinder Pressure Indicator

For measurement of variable pressure in cylinders and high pressure fuel pipes, electronic indicator Unitest has been used. It is six – way indicator with piezoelectric sensors of combustion pressure Kistler type 6353A24, light pipe sensors of injection pressure Operand AutoPSI-S-2000 and impulse head type MOC. It enables pressure measurements with discretion 0.5° of crankshaft angle.

Kistler sensors are connected by dedicated adapters, enabling measurement of combustion pressure before indicators cocks. Solution like that lets avoid errors of value run due to interference of the cocks. In this case, automatic recording of indicator charts on-line mode is possible.

Electronic indicator Unitest 2008 can be placed in a group of Mean Indicated Pressure (MIP) calculators. That device is a stationary indicator dedicated to measurement, digital recording and visualization of the runs of combustion pressure and fuel injection pressure in domain of crankshaft angle. The most important elements of the indicator are: pressure sensors, injection sensors, crankshaft angle sensor, signal amplifiers, analog-digital transducers and personal computer.

Tab. 1. List of registered parameters

Item	Name of parameter	Symbol	Unit	Measurement range
1.	Oil pressure before engine	P1	MPa	0 – 1 MPa
2.	Jacket water pressure	P2	MPa	0 – 1 MPa
3.	Sea water pressure	P3	MPa	0 – 1 MPa
4.	Charging air pressure	P4	MPa	0 – 1 MPa
5.	Sea water after intercooler pressure	P5	MPa	0 – 1 MPa
6.	Sea water after cooler	P6	MPa	0 – 1 MPa
7.	Jacket water after cooler pressure	P7	MPa	0 – 1 MPa
8.	Air inlet pressure	P8	MPa	0 -100 kPa
9.	Charging air temperature	T1	$^{\circ}\text{C}$	0 – 100 $^{\circ}\text{C}$
10.	Jacket water outlet temperature	T2	$^{\circ}\text{C}$	0 – 100 $^{\circ}\text{C}$
11.	Sea water before engine temperature	T3	$^{\circ}\text{C}$	0 – 100 $^{\circ}\text{C}$
12.	Sea water after cooler temperature	T4	$^{\circ}\text{C}$	0 – 100 $^{\circ}\text{C}$
13.	Sea water after oil cooler temperature	T5	$^{\circ}\text{C}$	0 – 100 $^{\circ}\text{C}$
14.	Sea water after cooler temperature	T6	$^{\circ}\text{C}$	0 – 100 $^{\circ}\text{C}$
15.	Lubricating oil temperature before engine	T7	$^{\circ}\text{C}$	0 – 100 $^{\circ}\text{C}$
16.	Exhaust gas temperature after cylinder 1	T8	$^{\circ}\text{C}$	0 – 600 $^{\circ}\text{C}$
17.	Exhaust gas temperature after cylinder 2	T9	$^{\circ}\text{C}$	0 – 600 $^{\circ}\text{C}$
18.	Exhaust gas temperature after cylinder 3	T10	$^{\circ}\text{C}$	0 – 600 $^{\circ}\text{C}$
19.	Exhaust gas temperature before turbocharger	T11	$^{\circ}\text{C}$	0 – 600 $^{\circ}\text{C}$
20.	Exhaust gas temperature after turbocharger	T12	$^{\circ}\text{C}$	0 – 600 $^{\circ}\text{C}$
21.	Engine rotational speed	n1	rpm	0 - 1000
22.	Turbocharger rotational speed	n2	rpm	0 - 1000
23.	Power of electro generator	NE	kW	0 - 500
24.	Fuel rack index	W0	-	0 - 10
25.	Air temperature after turbocharger	T13	$^{\circ}\text{C}$	0 -100

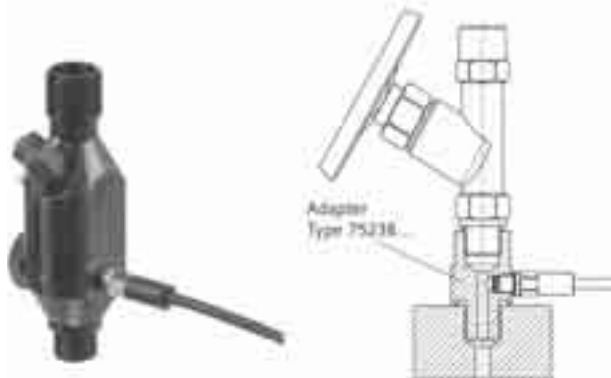

Fig. 4. Sensor's connecting adapter before the indicator cock

The indicator has been equipped with special program enabling measurement and visualization of pressure runs. Example of a window with combustion and injection pressure charts is presented on Fig. 5.

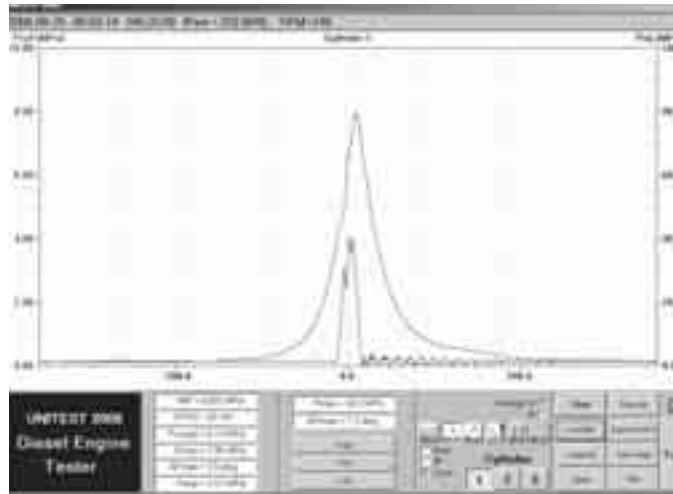

Fig. 5. Electronic indicator program window

The indicator program includes broad spectrum of options for easy analysis gathered runs of combustion and fuel injection. Extension of selected parts of a picture is possible, and run of functions can be related to mean values of all cylinders and values of reference. Apart from graphic analysis of runs, automatically following parameters of combustion and injection are determined:

- indicated power of the engine,
- mean indicated pressure,
- peak of combustion pressure,
- angle of combustion pressure peak,
- expansion pressure (at angle 360 after TDC),
- peak injection pressure,
- angle of injection pressure peak.

Combustion pressure sensors Kistler 6353A24 – specification

- Measurement range: 0 – 200 bar,
- Sensitivity: 50 μ A/bar,
- Nonlinearity and hysteresis: $\leq \pm 0.75\%$ FSO at 230 °C,
- Working range: -500 °C to 3500 °C,
- Sensitivity deviation due to temperature changes 23...3500 °C: $\leq \pm 2\%$,
- Sensitivity deviation due to temperature changes 200...200 °C: $\leq \pm 0.05\%$,
- Frequency range: 0.01Hz to 15 kHz,
- Output power: 8 – 20mA,
- Input voltage: 16 – 30V DC.

Fuel injection pressure sensors Optrand AutoPSI-S2000 – specification

- Maximum pressure: double value of the range,
- Nonlinearity and hysteresis: $\pm 0.5\%$ FS for measurement not related to combustion, in constant temperature $\pm 1-3\%$ FS for combustion pressure measurement, i.e., variable temperature related to combustion cycle,
- Resonance frequency: 120 kHz/min,

- Frequency range: 1.0 Hz to 25 kHz,
- Sensor body range: -400 °C to 3500 °C,
- Light pipe length: 2m,
- Pressure input signal: Analog: AutoPSI-S 0.5–3.6V,
- Power input: 85 mA max, 50 mA average.

Above stated elements are as follow: 6-channel vibration analyzer Brüel & Kjaer, acoustic emission recorder Vallen System, SEFRAM parameters recorder with 18 analog and 16 digital channels, Spectro Inc. Industrial Tribology Systems spectrometer dedicated to quick analysis of lubrication and hydraulic oils with detection of contamination by wear products or others like metal particles and additives, mobile exhaust gases analyzer Testo 350 XL, video-endoscope Everest XLG 3, thermo vision camera ThermoGear G100\G120. Implementation of above equipment, together with elaborated methodology of tests, enables proper verification and evaluation of condition of machines and mechanisms.

Modernization of the engine and extension of diagnostic base will enable carrying out research specified below:

- diagnostic research based on active experiment, leading to determination of diagnostic parameters' data base,
- diagnostic research of the engine's functional systems, especially turbo charging, fuel injection and piston-connecting rod ensemble,
- research related to the utilization of combustion pressure charts, high pressure fuel fluctuation analysis and acoustic emission, for marine engines diagnostics,
- research on influence of alternative fuels implementation at the engine exploitation parameters including exhaust gases composition and toxic,
- research on influence of mode of the engine exploitation at its elements condition, including elements after recovery treatment,
- research on possibility of utilization of data base information for automatic gathering of knowledge (inductive methods of machine learning and knowledge reveal methods).

References

- [1] Pawletko, R., Polanowski, S., *Influence of TDC determination methods on mean indicated pressure errors in marine diesel engines*, Journal of KONES Powertrain and Transport, Vol. 18, No. 2, pp. 355-364, Warsaw 2011.
- [2] Polanowski, S., Pawletko, R., *Acquisition of diagnostic information from the indicator diagrams of marine engines using the electronic indicators*, Journal of KONES Powertrain and Transport, Vol. 18, No. 3, pp. 359-366, Warsaw 2011.
- [3] Pawletko, R., Polanowski, S., *Research of the influence of marine diesel engine Sulzer AL 25/30 load on the TDC position on the indication graph*, Journal of KONES Powertrain and Transport, Vol. 17, No. 3, pp. 361-368, Warsaw 2010.
- [4] Polanowski, S., Pawletko, R., *Application of multiple moving approximation with polynomials in curve smoothing*, Journal of KONES Powertrain and Transport, Vol. 17, No. 2, pp. 395-402, Warsaw 2010.