

# THE PRELIMINARY DESIGN OF MULTIPURPOSE ENGINEERING MACHINE

**Łukasz Trzeciński**

*Military Institute of Engineer Technology  
Obornicka Street 136, 50-961 Wrocław, Poland  
tel.:+48 71 3474462, fax:+48 71 3474404  
witi@witi.wroc.pl*

## **Abstract**

*The preliminary design of a multipurpose engineering machine on the wheeled chassis was presented in the paper. The machine meets a series of specific requirements such as: off-road prowess, ability of movement with high speed on hard-surface roads, limited weight and dimensions at the maintaining of great hoisting capacity. These requirements were adjusted to the present character of warfare and that is why the machine construction deviates from classic working machines being used in the civil sector. The meeting of defined requirements required the development of innovative methods. The solution aiming at the increasing the stability of the machine by the application of using a sliding drive unit was described. As a result of that, the increased capacity and efficiency of mined materials were obtained. Additionally, the system of two telescopic arms was applied, so that the efficiency was improved by the shortening of machine working cycles and it is possible to change the length of arms as well as both telescopic arms were placed on the rotating body achieving in such a manner the big workspace for arms. The 3D model of a multipurpose engineering machine and model with rear mounted drive unit and raised and extended arms are presented in the paper*

**Keywords:** *engineering machine, working machine, loader, stability, preliminary design, multipurpose machines*

## **1. Introduction**

The changing nature of warfare, which is manifested by the growing intensity of engineer support, forces the use of universal machines that have a wide operating range. It can be observed at the same time that as the requirements of the battlefield increase, the quality of equipment will be better and continuous improvement (modernisation) of the equipment is needed.

Contemporary combat operations pose special requirements to engineer vehicles, which should be able to move freely under hard conditions. The free movement consists of such elements as speed, manoeuvrability, range and off-road prowess. It should be distinguished the tactical and operational mobility. Vehicles, which are capable of driving on good roads with great speed, are characterized by insufficient manoeuvrability and crossing ability and they are devoid of the tactical mobility. However, the vehicles, which are characterized by good manoeuvrability and crossing ability and driving too slow on good roads, are devoid of operational mobility. The creative balance between defining characteristics of tactical and operational mobility determines the value of a vehicle. Except for it, an engineer vehicle should be characterized by the so-called strategic mobility, i.e. it should be suited to the land, water and air transport. The special requirements in that field are defined by the air transport, both overall dimensions and weight.

## **2. Project**

The development of the appropriate preliminary project is significant for further forming and using the machine. That is why the presented project was preceded by a thorough analysis of

current solutions for working machines relating to requirements, which should be met by the machine.



*Fig. 1. 3D model of a multipurpose engineering machine*

Basing on definite requirements, which should be met by an engineering machine, the 3D vehicle model was developed (Fig. 1) in the Inventor programme. The type and layout of the machine chassis was chosen from among 13 types of combinations of different chassis types, including a tracked chassis as well as a tracked-wheeled one. Various variants of chassis solutions were assessed taking into account assumed criteria. The chassis with three torsion axles, where each of the axles is a driving axle got the highest score. The machine is characterized by the appropriate off-road mobility and three torsion axles provide high manoeuvrability, what is connected with the better performance. Two front axles of the machine provide adequate capacity for heavy duty arms. The drive unit frame 1 (Fig. 2) together with this unit 2 is placed at the rear of the main frame. The drive unit frame 1 is able to change its position relative to the main frame by use of working sliding elements 3, which can change the drive unit position thanks to the guides 4. One of the solution includes also a loader unit, which is characterized by a big workspace using a rotating body 5 and two telescopic arms 6 (not one as in the previously known solutions) were placed on the body. Two sliding supports with vertical feet 7 were mounted on the ends of the main frame at the front and rear. The supports are applied in this solution due to the great hoisting capacity, the using of supports is limited, and they are used only at unloading and loading of big masses when there is a need to carry out the body 5 rotation.

The above-mentioned solutions are filed at the Patent Office of the Republic of Poland.

The advantage of the engineering machine with the sliding drive unit is the increased stability obtained by changing the centre of gravity of the entire vehicle, which is achieved by adjusting the relative position of the drive unit frame together with this unit with respect to the main frame in a horizontal plane without increasing the weight of the machine by use of outside ballasts.

The advantage of this solution is also the capability to adjust smoothly the position of the drive unit together with its frame to the machine working conditions. It allows obtaining larger values of the reaction on machine front wheels, what causes the increasing the cutting force into the mined medium due to maximum approximation of the bucket centre of gravity, in the case when the bucket moved upward under load, the drive unit is away from the bucket centre of gravity. In addition, the engineering machine has a big workspace of loader fittings. Due to the possibility of rotating the body, the loader is capable of side unloading without the necessary time-consuming positioning of the machine and the use of telescopic arms allow you changing their length and the workspace, if necessary. Two telescopic arms have a positive effect on the system stiffness when the mined medium exerts pressure on the loader bucket.

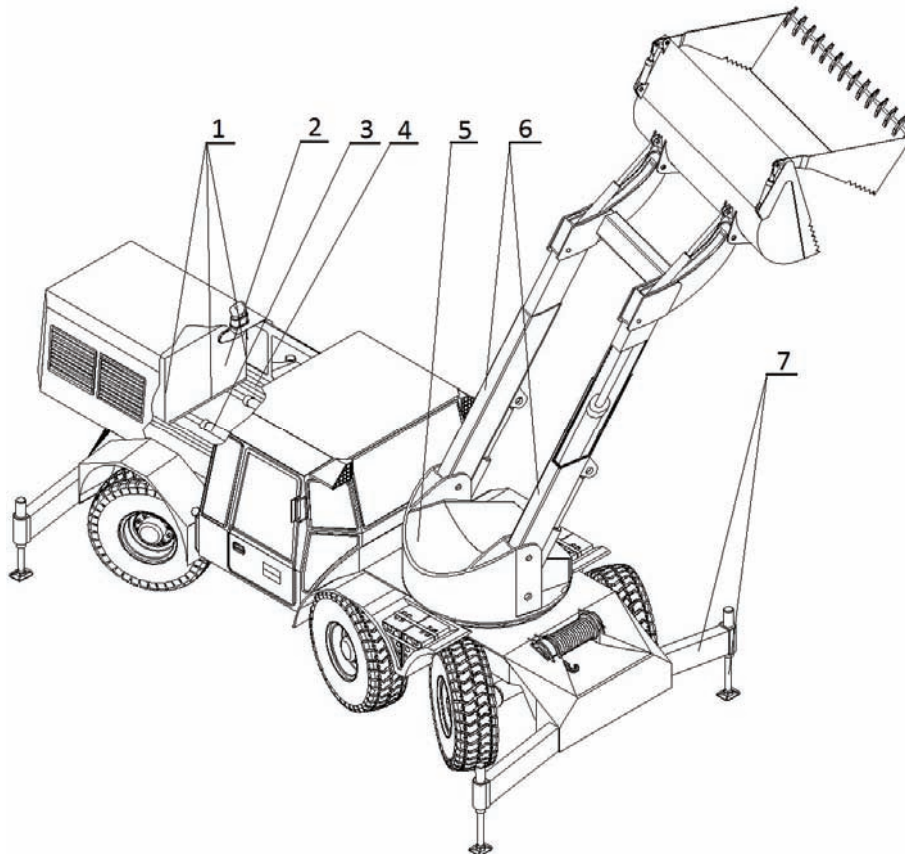

*Fig. 2. Model with rear mounted drive unit and raised and extended arms*

## References

- [1] Dziama, A., *Metodyka konstruowania maszyn*, PWN, Warszawa 1985.
- [2] Pieczonka, A., *Ładowarki łyżkowe*, Wydawnictwo Politechniki Wrocławskiej, Wrocław 1975.

