

## PRELIMINARY INVESTIGATIONS OF THE HCCI COMBUSTION SYSTEM IN A SINGLE CYLINDER RESEARCH ENGINE

Krzysztof Motyl, Aleksander Lisowski

Warsaw Agricultural University (SGGW)  
Nowoursynowska 166, 02-787 Warsaw, Poland  
tel.: +48 22 5934538, fax. +48 22 5934514  
e-mail: krzysztof.motyl@ge.com, aleksander\_lisowski@sggw.pl

### Abstract

*This paper describes the results of the preliminary experimental research of the HCCI combustion system in a single cylinder research engine fuelled by means of natural gas containing 95% methane. In this research, influence of the initial temperature of the charge and mixture composition on the maximum combustion pressure, maximum speed of pressure growth, selfignition delay time, combustion time, maximum combustion temperature, heat release and combustion efficiency have been studied. The paper contains: description of the engine modification to adopt it for HCCI operation requirements, applied measurements equipment, selected results of the experimental research. The results shows that initial charge temperature and mixture composition (relative air/fuel ratio coefficient) have essential influence on the engine operating results. The experimental research has been conducted for the varied initial charge temperature from 140 °C up to 210 °C and for varied relative air/fuel ratio coefficient  $\lambda=1$ ;  $\lambda=1.5$ ;  $\lambda=1.7$ ;  $\lambda=2$ . Maximum charge pressure, maximum speed of pressure growth selfignition delay time was rather unaffected on the initial charge temperature increase beyond 200 °C. Previous and current author's research works have indicated that extremely low emissions and high combustion efficiencies are possible to reach if homogeneous charge compression ignition is applied.*

**Keywords:** thermodynamics, internal combustion engines, HCCI, combustion process, exhaust emission, bio-fuel

### 1. Introduction

This paper shortly describes history of research work, their results, advantages and problems following from specific combustion process, characteristic for HCCI engines. Next part of the paper presents instrumentation, implemented modifications in single cylinder engine and additional equipment required to convert conventional engine to HCCI combustion. Obtained results are presented in the form of diagram characteristics and their analyses.

Reducing exhaust emissions and increasing the fuel economy of internal combustion engines are presently a global importance. To meet the demand of: economy, energy saving, exhaust emissions, especially carcinogenic NO<sub>x</sub>, and responsibility for a greenhouse effect CO<sub>2</sub>, higher thermal efficiency, present generation engines must be characterized by: lower fuel consumption; higher efficiency; higher reliability; lower price and smaller cost of usage. New type of engine combustion process such a Homogeneous Charge Compression Ignition is seen among the most promising ways to meet the market and environmental challenges of the future power unit used to produce electricity, and as the cars propulsion widely used in transportation. Additionally, those new engines have to meet strict regulations concerning CO<sub>2</sub> and NO<sub>x</sub> emissions, together with increased efficiency that it expresses in low fuel consumption.

Engines operate basis of a new combustion process such as Homogeneous Charge Compression Ignition supplied by methane is seen among the most promising ways to meet the environment challenges of the future engines used in transportation with associated robust ultra low pollutant emissions. Besides that engine promises thermal efficiencies comparable or higher than those

attained by high compression ratio, unthrottled diesel engines while maintaining the smoke – free operation of spark – ignited engines. This new type of combustion does not possess normal flame propagation, instead of that, the entire charge in the combustion chamber is burned in non-flame mode, almost in the same time. For the reason of design and work principle, this kind of engine is operated unthrottled thus pumping losses are significantly reduced especially during low and partial load. New type of combustion applied to the engines required high compression ratio, similar or even higher than those used in Diesel engines. In order to control the energy release – knock intensity – engine must be operated at high level of mixture dilution. This combination of high compression ratio and lean – burn mode, is an effective way to meet the demand for energy saving, higher thermal efficiency and low harmful exhaust emissions. Unlike a diesel engine, HCCI combustion takes place homogeneously throughout the whole mixture in combustion chamber. Since there is no fuel-rich diffusion flame burning, the particulate emissions are at the zero levels. The reduction in  $\text{NO}_x$  emissions results from the decrease burned gas temperature. The  $\text{NO}_x$  emission levels are well below even from spark ignition engines with direct injection and stratified charge, and stoichiometric port injection equipped with complex three-way catalyst system. Indeed, an HCCI engine offers the potential fuel economy comparable, or better in comparison with diesel engines. While the potential advantages of HCCI combustion are great, this combustion also poses its own set of unique problems, such as high HC and CO emissions, knock intensity during load increase and difficulty in combustion phasing control especially during variable load of engine operation. Achieving the ability to control phasing combustion during transient engine operation and reducing level of unburned hydrocarbons would be the key to successful HCCI engine introduction to the world market.

The first studies regarding HCCI were conducted on two-stroke engines by Onishi et al. in 1979 [4] and by Noguchi et al. [6]. In 1983 Najt and Foster [5] showed that it is possible to achieve HCCI combustion in four-stroke engine. Ever since HCCI has been studied by a number of researches, most of these research works concerned: different concepts of HCCI, operational range, limits of mixture composition, used fuels, chemical kinetic reactions, supercharging, water injection, etc. [1, 2, 9, 10]. Authors of this paper are engaged in HCCI research since 2000 year [3]. They have conducted preliminary research in the rapid compression machine [4] where modelled HCCI combustion. At present the researches are conducted to realize feed system of the research engine with biogas [5] that currently is irreparable loss. Increase methane contents in the biogas up to 95% permit to apply biogas as a fuel driving engines.

## 2. Experimental

The experimental engine is one cylinder, four strokes, compression ignition engine, which was designed to research the influence of the swirl and turbulence on the mixture preparation process and combustion process. The engine was modified to realize HCCI combustion mode. Table 1 presents the major engine specifications. The research engine was equipped with following systems: air supply system, fuel (natural gas) injection supply system, measurement and control systems. Figure 1 presents schematic test set up, Figure 2 shows view of research engine set up. The air supply system was designed to provide relevant parameters of the charge (temperature, pressure, relative air/fuel ratio and volumetric efficiency).

The air supply system include: pressurized reservoir, heat exchanger, heat exchanger control system, flow meter, temperature and pressure measurement equipment. The inlet air was heating by means of specially designed heat exchanger consist of electric heater with power about 30 kW allowed to obtain inlet air temperature around 250° C during one minute. Air temperature was controlled in closed loop control system with accuracy  $\pm 0.5^\circ$  C. One of the drawbacks of intake manifold is a very small cross section, which in other side allowed gaining big air flow speed, expressed in the swirl and turbulence in the research engine cylinder. This feature of inlet system

was used to obtain as quickly as possible homogeneous air-gas mixture in research engine cylinder. Natural gas was injected upstream to air into the directed groove in the cylinder head. By means of such designed inlet system authors obtained high relative velocity air and natural gas what facilitate creating homogeneous mixture.

Tab. 1. Research engine specifications

Bore [mm]	102
Stroke [mm]	120
Displacement [cm <sup>3</sup> ]	980
Combustion chamber volume [cm <sup>3</sup> ]	75
Compression ratio	14.1:1
Length of connecting rod [mm]	217

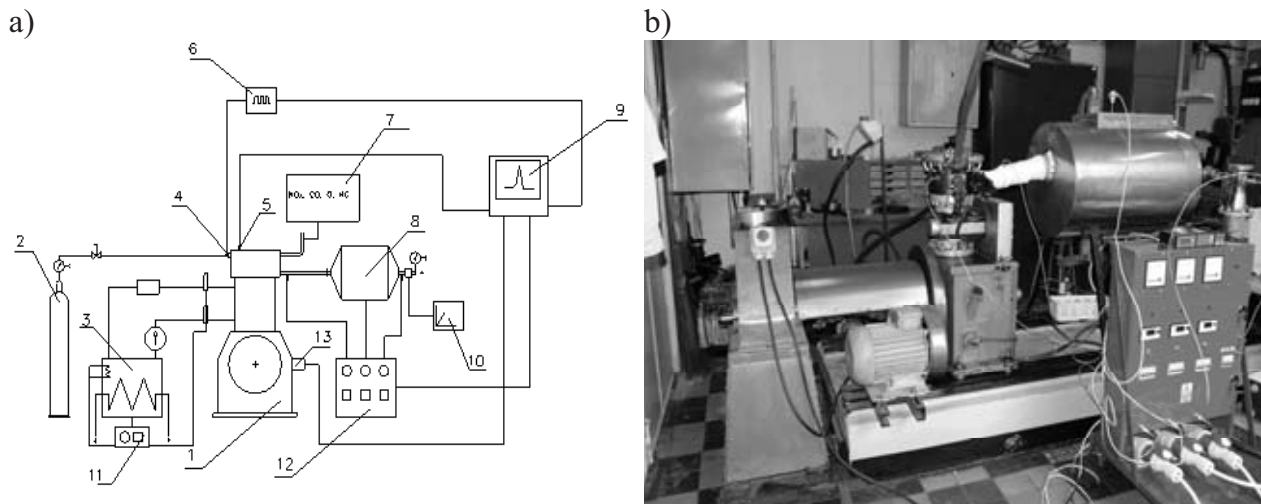

Fig. 1. Experimental set-up HCCI engine, a) Schematic, b) View: 1 – Experimental engine, 2 – Pressurized methane bottle, 3 – Cooling/heating fluid tank, 4 – Methane injector, 5 – Pressure transducer, 6 – Control system of gas injection, 7 – Exhaust Gas Analyzer System, 8 – Air reservoir, 9 – Acquisition system, 10 – Air rate measuring system, 11 – Control system of heating and flow rate of cooling liquid, 12 – 30 kW power air heater, 13 – Crank angle measuring system

Small cross section of inlet manifold required to provide the supply air from air system installation pressurized to about 0.3 MPa. Such system was required because normally aspirated engine has volumetric efficiency coefficient only 0.3–0.4 and was impossible to obtain required compression pressure that ensure mixture selfignition. When pressurized system was used volumetric efficiency coefficient increase in range from 0.92 to 0.95. Applied turbine flow meter type AMX 403 was used to measure mass flow rate. During conducted experiments the air temperature was varied from 140° C to 210° C with 10° C steps. Natural gas was injected to air with specially designed and built by author natural gas injector. An injector was equipped with high-speed reaction electromagnetic valve Servojet Product Inc. Injection pressure was 2 MPa but the pressure in the gas bottle was 15MPa.

Cylinder pressure tracers were measured using a water-cooled pressure transducer Kistler 6053A, amplifier 5011 and crank angle encoder PFI 80. The measurement data were acquired with AVL Data Acquisition System Indiskope 427. The results reported in this paper concern varied temperature from 140° C to 210° C and varied air/fuel ratio  $\lambda=1$ ;  $\lambda=1.5$ ;  $\lambda=1.7$ ;  $\lambda=2$ . Temperature measurements were performed with thermocouples type K and registered with special A/C chart.

The research engine was driven by electric motor with belt reduction transmission gear at constant speed 800 RPM.

Figure 3 shows schematic of cylinder head equipped with natural gas injector and water-cooled pressure transducer. Figure 4 presents a view of cylinder head with directional groove made in lower face of cylinder head.

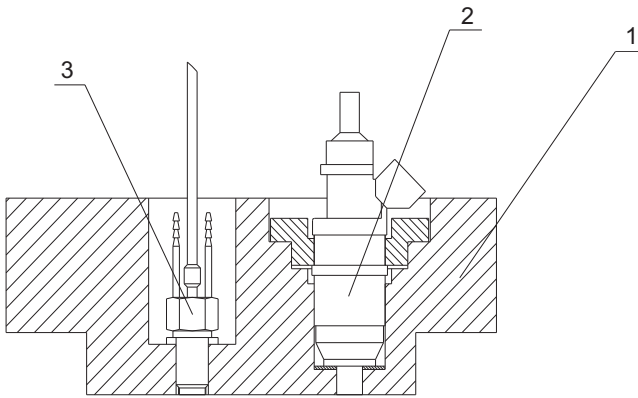

Fig. 3. Schematic of cylinder head 1-cylinder head, 2-injector, 3-pressure transducer



Fig. 4. View on directional groove in lower face of cylinder head

The experiments results were processed mainly to determine effect of the initial temperature and air/fuel ratio coefficient on the combustion maximum pressure, maximum pressure speed growth, selfignition delay timing, combustion efficiency, maximum combustion temperature and heat release heat. Maximum combustion temperature and heat release rate were calculated from pressure traces in combustion chamber that have been registered during engine operation.

### 3. Results and discussion

Figures 5 and 6 show typical pressure traces which were measured at varied initial charge temperature (from 140° C to 210° C) as a function crank angle position of crankshaft, for relative air/fuel ratio coefficient  $\lambda=1$  and  $\lambda=2$  respectively. The traces of the pressure are quite similar in different temperatures and different air/fuel ratio, but they various in selfignition delay time and maximum combustion pressure and temperature. Selfignition delay time is measured from the beginning compression stroke because mixture has sufficient temperature to start pre flame reactions. As initial temperature is increased, the selfignition delay time decreases. Maximum combustion pressures as a function of initial temperature for different mixture composition are shown in figure 7. It can be seen that at the beginning maximum combustion pressure growths if initial temperature increase, but since any value of initial temperature of the charge is kept at fixed level. For constant initial temperature of the charge was found big differences of maximum combustion pressure for various mixture compositions.

Figure 8 are presented curves that represent dependence between combustion maximum combustion temperature and relative air/fuel ratio coefficient. As relative air/fuel ratio coefficient increases the maximum combustion temperature decreases. The effect of  $\lambda$  coefficient is most pronounced for initial temperature of the charge between 140° C and 160° C. If initial temperature

is higher than 160° C the differences of maximum combustion pressure is smaller. Differences between maximum combustion pressure decrease when relative air/fuel ratio increase.

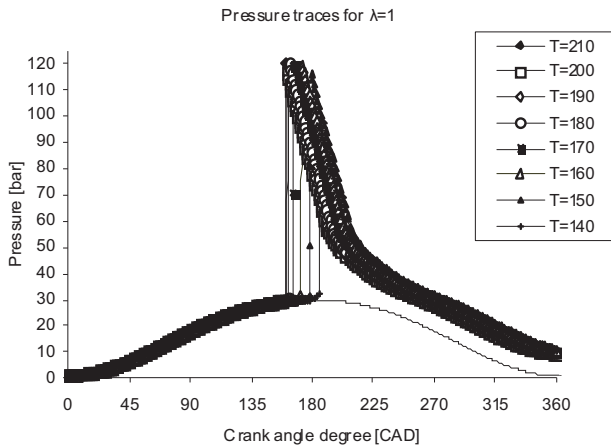

Fig. 5. Combustion chamber pressure traces for different initial charge temperature, for relative air/fuel ratio coefficient  $\lambda=1$

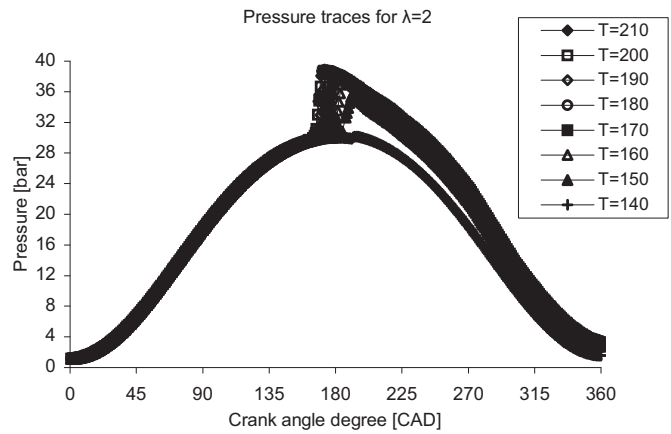

Fig. 6. Combustion chamber pressure traces for different initial charge temperature, for relative air/fuel ratio coefficient  $\lambda=2$

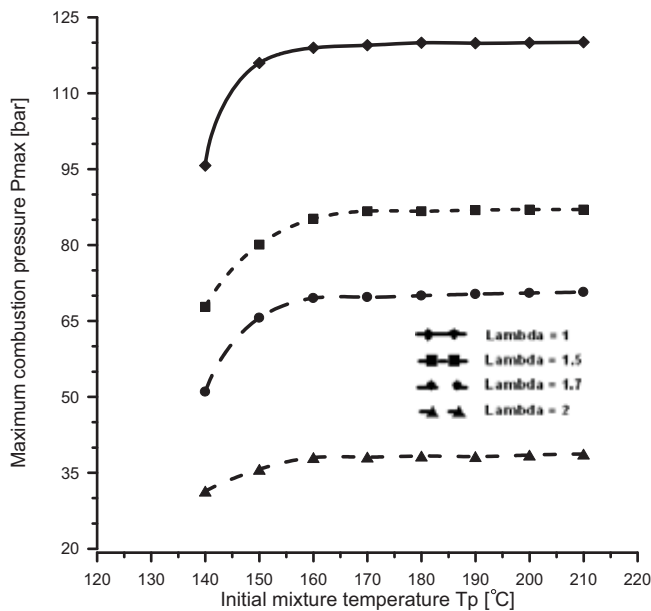

Fig. 7. Maximum combustion pressure versus initial charge temperature for different relative air/fuel ratio coefficient

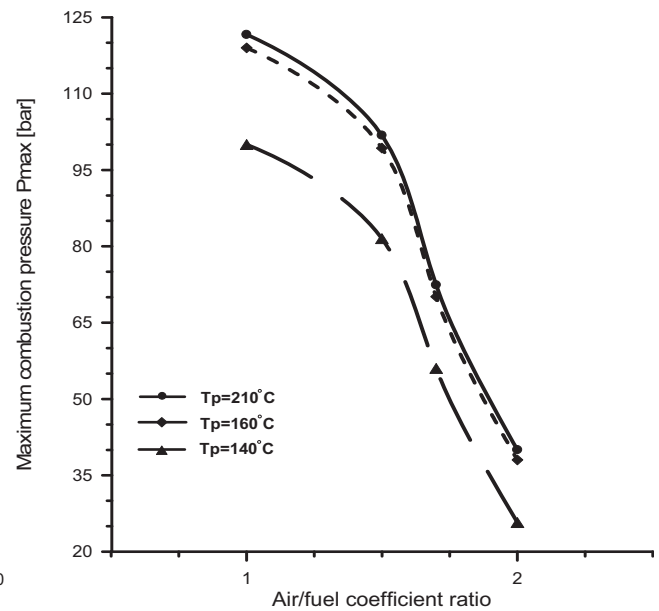

Fig. 8. Maximum combustion pressure as a function of relative air/fuel coefficient for constant initial charge temperature: 140° C and 160° C and 210° C

Figure 9 shows the dependences between pressure speed growth and initial charge temperature, for different constant values of relative air/fuel ratio coefficient. The traces of the curves are similar to traces of maximum combustion pressure versus initial charge temperature. As initial charge temperature increases maximum speed of pressure growth increases too. It can be seen as big differences for maximum speed of pressure growth, for different values of relative air/fuel ratio coefficient in constant initial charge temperature. This is presented in figure 10.

The maximum values of speed pressure growth are for  $\lambda=1$  and initial charge temperature higher than 160° C. They amounted was 1.56 MPa/CAD. As initial charge temperature was above 160° C maximum values of speed pressure growth are almost constant. Therefore in figure 10 curves for

initial air temperature values of 140° C and 210° C are only presented. Differences in maximum speed of pressure growth for different  $\lambda$  at the same but varied initial charge temperature are similar. The effect of  $\lambda$  is the most pronounced when  $\lambda$  is varied from  $\lambda=1.7$  to  $\lambda=2$ . The  $\lambda$  changes from  $\lambda=1$  to  $\lambda=1.7$  causes a reduction of  $dp/d\phi$  about 450%. For the maximum pressure in combustion chambers increase of  $\lambda$  from  $\lambda=1$  to  $\lambda=2$  causes variations of this pressure, at constant temperature, about 350%. This means that the mixture composition has bigger influence on maximum speed of pressure growth than on the maximum combustion pressure.

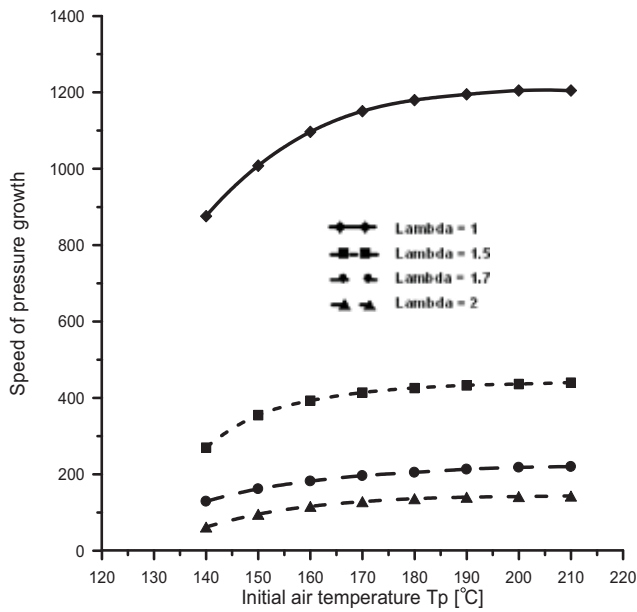

Fig. 9. Maximum speed of pressure growth versus initial charge temperature for different relative air/fuel ratio coefficient

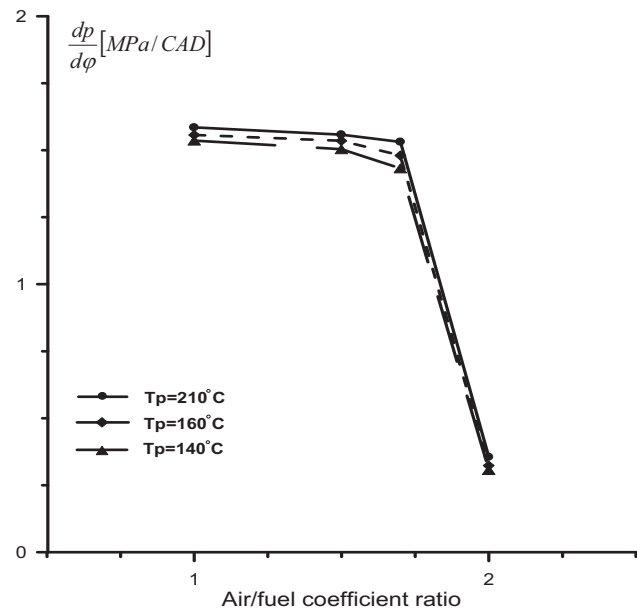

Fig. 10. Maximum speed of pressure growth as a function of relative air/fuel ratio coefficient, for constant initial charge temperature 140° C, 160 C and 210° C

Figure 11 shows dependence between selfignition delay time and initial charge temperature for different mixture composition. The selfignition delay time was measured from the beginning of compression stroke because initial temperature of the charge is so high that precombustion chemical reactions start to run. As evidenced by figure 11 the increase of initial charge temperature causes reduction of selfignition delay time. The smaller relative air/fuel ratio coefficient ( $\lambda$ ) the shorter is selfignition delay time. When initial charge temperature reaches 200° C the ignition delay time reaches almost fixed level; variations are very small. So further growth of initial charge temperature, beyond 200° C, do not cause variation neither selfignition delay time, maximum combustion temperature, neither maximum speed of pressure growth.

Figure 12 shows dependence between maximum temperature values in combustion chamber and initial temperature of the charge for fixed mixture composition  $\lambda$ . These values were determined from pressure traces in combustion chamber during engine operations. The higher values of initial charge temperature and smaller values of relative air/fuel ratio coefficient mean higher values of temperature in combustion chamber. The traces of maximum temperature in combustion chamber are similar to maximum pressure traces; at beginning the temperatures in combustion chamber increase if initial temperature grows, but exceed any value they fix at almost constant level. Maximum value of combustion temperature which have been determined in this method for  $\lambda=1$  and  $T_p=140^\circ\text{C}$  is 1500 K but for  $\lambda=1$  and  $T_p=210^\circ\text{C}$  is 1638 K, however for  $\lambda=2$  and  $T_p=140^\circ\text{C}$  is 906 K, but for  $\lambda=2$  and  $T_p=210^\circ\text{C}$  is

1080 K. Mixture composition and initial charge temperature have significant influence on the temperature of the charge in combustion chamber. The combustion efficiency versus initial charge temperature for different relative air/fuel ratio coefficient ( $\lambda$ ) is presented in figure 13.

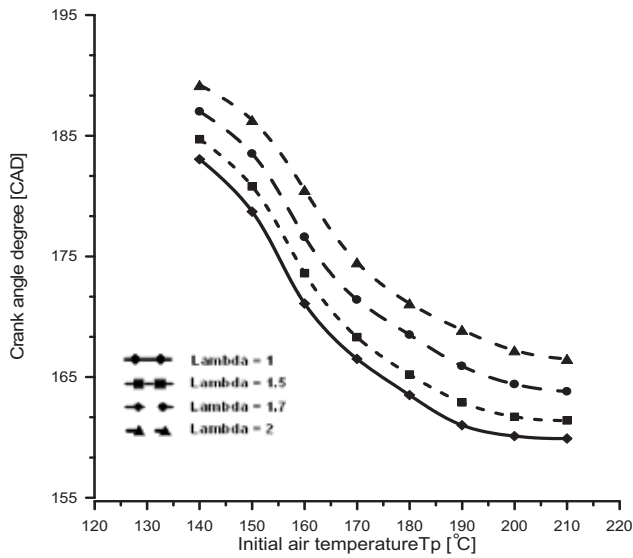

Fig. 11. Selfignition delay time versus initial charge temperature for different relative air/fuel ratio coefficient

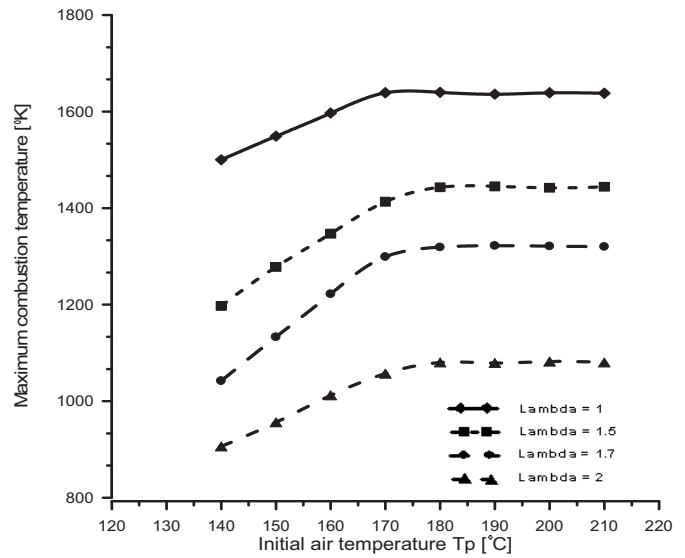

Fig. 12. Dependence between maximum temperature in combustion chamber and initial charge temperature for different relative air/fuel ratio

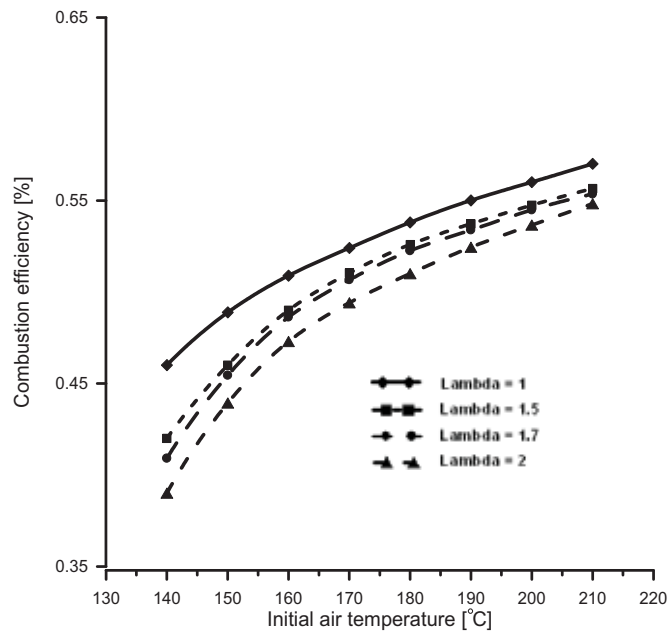

Fig. 13. Combustion efficiency as a function of initial charge temperature, for different relative air/fuel ratio coefficient

It is apparent that growth of initial charge temperature causes increase of combustion efficiency. For fixed initial temperature are visible meaningful differences in combustion efficiency for various mixture compositions. These differences decrease when initial temperature increases. At fix level of the air/fuel ratio, when initial temperature increases it needs to reduce quantity of fuel to keep constant air/fuel mixture. In spite of smaller quantity of the fuel in mixture combustion efficiency increases but maximum combustion pressure practically keep steady at the same level.

#### 4. Conclusion

The research carried out on the new HCCI combustion system showed that initial temperature of the charge and mixture composition (relative air/fuel ratio coefficient) have essential influence on: maximum combustion pressure and temperature, maximum pressure growth speed, combustion time and selfignition delay time, rate and quantity of heat release, combustion efficiency. Therefore the initial temperature and mixture composition can be regards as control parameters in realization of HCCI combustion in piston engines. The research results have preliminary character because they have performed only for one of engine speed and limited quantity of air/fuel ratio coefficient where during normal cycle life engine operates with countless various load and speed. It is onerous and very time-consuming task. Authors in their work proved that increasing the initial temperature cause changes in maximum combustion pressure and temperature, maximum speed of pressure growth, selfignition delay time and their derivative to the determined value. Further growth of the initial temperature doesn't cause any changes in these parameters. By confronting those results of the research with engine performance data it will be possible to arrive at answers to some basic questions how to organize the combustion process in point of view on maximum engine economy and environmental impact.

#### References

- [1] Christensen, M., Johansson, B., Amneus, P., Mauss, F., *Supercharged Homogeneous Charge Compression Ignition*, SAE 980787.
- [2] Flowers, D., Aceves, S., Westbrook, C.K., Smith, J.R., Dibble, R., *Detailed Chemical Kinetics Simulation of Natural Gas HCCI Combustion, Gas Composition Effects and Investigation of Control Strategies*, Transactions of the ASME, Journal of Engineering for Gas Turbine and Power, Vol. 123, April 2001.
- [3] Motyl, K., Rychter, T.J., *HCCI Engine – a Preliminary Analysis*, Journal of KONES, Internal Combustion Engines, Vol. 10, 2003.
- [4] Motyl, K., Rychter, T.J., *Preliminary Investigation of the HCCI Combustion System in a Rapid Compression Machine*, Journal of KONES, Internal Combustion Engines, Vol. 11, 2004.
- [5] Motyl, K., Lisowski, A., *Możliwości wykorzystania silnika pracującego na ładunku jednorodnym według koncepcji HCCI zasilanego biogazem, (Possibility of the utilization of the HCCI engine supplied by biogas)*, Problemy Techniki Rolniczej i Leśnej VI Międzynarodowa Konferencja Naukowa, Warszawa 2007.
- [6] Najt, P.M., Foster, D.E., *Compression-Ignited Homogeneous Charge Combustion*, SAE 830264.
- [7] Noguchi, M., Tanaka, Y., Tanaka, T., Takeuchi, Y., *A Study on Gasoline Engine Combustion by Observation of Intermediate Reactive Products during Combustion*, SAE 790840.
- [8] Onishi, S., Hong, Jo S., Shoda, K., Do, Jo P., Kato, S., *Active Thermo-Atmospheric Combustion (ATAC) – A New Combustion Process for Internal Combustion Engines*, SAE 790501.
- [9] Wyszynski, M.L., Xu, H., *HCCI with Standard and Alternative Fuels at Moderate Compression Ratios*, I Międzynarodowy Kongres PTNSS, No. PTNSS P05-C151, 2005.
- [10] Zhao, H., Peng, Z., Laddomatos, N., *Understanding of Controlled Auto ignition Combustion in a Four-Stroke Gasoline Engine*, Proceeding of the ImechE, Journal of Automotive Engineering, Part D, Vol. 215, 2001.