

THE POSSIBILITY OF DIAGNOSIS EGR SYSTEM'S DEFECTS BY VIBRATION ANALYSIS

Andrzej Kaźmierczak, Radosław Wróbel

Wroclaw University of Technology
Institute of Machine Design and Operation
Łukasiewiczza Street 7/9, 50-371 Wrocław
e-mail: andrzej.kazmierczak@pwr.wroc.pl
radoslaw.wrobel@pwr.wroc.pl

Abstract

The Exhaust Gas Recirculation is a popular system of recirculation of the automotive vehicle emission. The principle of working depends on the forcing in the part of outlet gas to the combustion chamber. Majority of the users of automotive vehicles with EGR systems claim that system has negative effect on the performance of the car. Nonetheless that opinion is subjective, because the generally available research on the subject doesn't exist. However, EGR system, as the most of automotive vehicle is being subjected to physic's rules - it uses up. The polluted flowing valve of circuit has an influence on stability of engine's work, and what follows on a performance of a car. The authors presents a new in - vitro way of diagnosis in automotive vehicle which depend on detection and measure of vibroacoustic vibrations of the diesel engine. It seems that EGR circuit that does not work properly shouldn't have an influence on vibrations generated by an engine. However, authors indicate that this statement is wrong. EGR system has an influence on engine's vibration, what was described in the article. On that way, detection of vibrations must be accomplished with high quality diagnostic systems. Therefore, vibrometric laser scanner Polytec had been used. To achieve full diagnostic results multidimensional vibration's function has been researched, where the torque moment has been used as an extra parameter. Measured vibrations were subjected to digital signal processing like windowing, fast Fourier transform, filtration by finite impulse response. The results of measure and processing perform in form of 3D plots, which indulge in speed estimate of the usefulness of presented method. Moreover authors presents principle of working EGRs' systems of different generations and its evolution.

Keywords: EGR system, fast Fourier transform, automotive diagnosis, vibroacoustic analysis

1. Introduction

Since the 1960s, when rapid degeneration of the environment was first noticed, ways of reducing the emission of dangerous substances by automotive vehicles have been sought. The dangerous compounds are hydrocarbons (HC), nitrogen oxides (NO_x) and carbon dioxide (CO₂). The dangerous emissions can be reduced by [1]:

1. improving the fuel,
2. improving lubrication,
3. maintaining higher thermal stability,
4. perfectly insulating the system,
5. using catalytic systems.

Among the systems which have a bearing on engine thermal economics by reducing lean mixture temperature there is the Exhaust Gas Recirculation (EGR) system whose principle of operation consists in forcing some of the exhaust gas back into the combustion chamber [2].

The first experiences with EGR systems date back to the 1970 s. The operation of the system was then limited to steady feeding the exhaust gas to the combustion chamber when the vehicle user turned on the system by means of a proper switch. That system only partially fulfilled its functions which included [3]:

1. lowering the combustion temperature of the lean mixture,
2. oxidizing harmful substances,
3. accelerating fuel vaporization.

As one can easily guess, the first vehicles with the EGR, which, thanks to General Motors, appeared on the American market in 1973 contributed little to emission reduction. It was mainly the fault of the human being who would decide when the EGR was and was not to work. In the late 1970 s the system was improved by introducing a primitive diagnostic system whose integral part was a temperature sensor located on the cooler. It would turn on the EGR (provided the decision unit, i.e. the human being, had switched on the whole system) only at specified engine (coolant) temperatures. The next generations of the system were equipped with timing circuits which would switch off the EGR for a few seconds after the throttle was fully opened.

In 1983 research on the 4th generation EGR which is human-independent, i.e. it takes its own decisions about switching the system on or off, started. Besides taking the right switching decision, the system also decides what percentage of the exhaust gas can be turned back to the combustion chamber. The modern EGR takes a decision to switch on the system only if the following conditions are fulfilled [3]:

1. the engine temperature is higher than 77°C,
2. the temperature under the bonnet is above -6°C,
3. the engine has been working for at least 3 minutes at the above temperatures,
4. the crankshaft rotational speed is 1952-2400 rpm for the manual gearbox,
5. the crankshaft rotational speed is 2248-2688 rpm for the automatic gearbox,
6. the exhaust gas overpressure is 667-2667 Pa,
7. the fuel temperature does not differ from the one specified by the vehicle manufacturer (T_0) by -8% to + 7%,
8. the voltage generated by the throttle opening sensor is in a range of 0.6 - 1.8V,
9. the driving speed is higher than 40 km/h.

2. Operation of EGR

Although the idea seems to be simple, since it consists in pumping some of the exhaust gas back to the combustion chamber, its implementation is not so obvious. Two groups of systems [5] are distinguished:

1. pneumatically controlled,
2. electronically (processor) controlled.

As a rule, the operation of electronically controlled systems is based on a decision unit in the form of a (micro-) processor system. The decision whether to switch the system on and about the amount of exhaust gas which is to be forced back into the combustion chamber belongs solely to the integrated circuit which takes the decision on the basis of the information coming from the sensor CAN bus.

The EGR, belonging to the group of negative pressure-controlled sensors [2], is employed in both supercharged and unsupercharged engines. Generally speaking, in all the EGR systems known so far the valve is opened by a negative-pressure servomotor and closed by an elastic element [5]. Subpressure is produced by a double-purpose pump called a tandem pump, which is a combination of a fuel pump and a subpressure pump in one housing (Fig. 2). The subpressure value is adjusted by an electrovalve controlled by the information contained in the rectangular signal. In this case, this is pulse-duty factor k_w :

$$k_w = \frac{t_i}{T}, \quad (1)$$

where: t_i - pulse duration, T - the period.

When the pulse - duty factor is close to 0, the electrovalve is closed. The degree of valve opening is directly proportional to the value of the factor and the maximum opening is reached at $k_w = 1$.

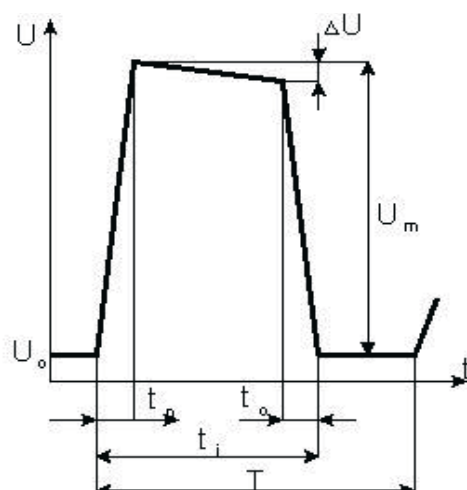

Fig. 1. Ideal pulse

The control system allows switching on the ERG only in certain engine operating conditions (described in chapter 1). But never the entire exhaust gas is forced back into the combustion chamber. The amount of exhaust gas which is forced in depends on [5]:

1. the mass of the air sucked in by the engine,
2. the volume of the air sucked in by the engine,
3. the throttle opening angle,
4. the absolute pressure in the intake manifold,
5. the exhaust gas overpressure in the exhaust system.

3. EGR failures

In the literature on the subject and also on Internet forums the EGR and the need for its existence are often discussed. Unfortunately, many users who know how the EGR system works switch it off to improve the performance of their vehicles and prevent failures in the intake systems [4]. As a result, the EGR valve in the supercharged engine gets gummed up, as shown in Fig. 5. Carbon deposit accumulation may totally block the EGR electrovalve and thereby damage the lambda probe, which leads to serious consequences.

The EGR valve can also be blocked when the negative-pressure system is untight or the pulse length control system is damaged. Negative-pressure system leakage is a typical failure of systems controlled in this way. The problem here is that the pipes feeding negative pressure to the EGR system are located close to the hot engine parts. Damage to a negative pressure feeding pipe results in, among other things, engine stalling both when the engine is cold and hot.

Besides the failures mentioned above, the systems of sensors which aid the processor unit in taking the ERG system switch on decision may fail. The sensors include [6]:

1. A coolant temperature sensor (CTS), which is an NTC (Negative Temperature Coefficient) thermistor. A throttle position sensor (TPS), which is a potentiometer measuring voltage drop.
2. An oxygen sensor (OS), which is located in the throttle system and measures air volume. It usually works in tandem with a rate generator coupled with an a/d converter.
3. An intake air temperature (IAT) sensor, which, similarly as the coolant temperature sensor, is an NTC thermistor. As opposed to the thermistor which measures coolant temperature, a semiconductor thermistor with a different dopant is used in this case.
4. A crank sensor (CS).
5. A manifold absolute pressure (MAP) sensor.

A failure of any of the systems mentioned above will cause a malfunction of the EGR system. EGR faults have special a special symbol in the EOBD (OBDII) code, i.e. the value 4 in the 3rd field of the fault code [5].

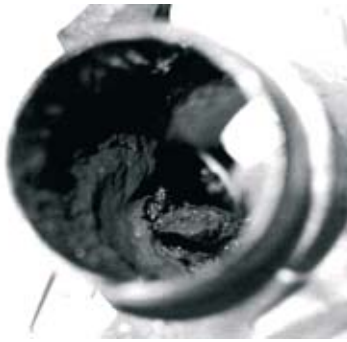

Fig 2. Gummed up intake valve of EGR [4]

A new method of diagnosing the EGR system, based on the multidimensional function of compression-ignition engine vibration, is presented below.

4. Measurement methodology

Since 2008 the CAN bus can be the only diagnostic medium in automotive vehicles. Furthermore, since 2001 each new European vehicle has been equipped with the European On Board Diagnostics (EOBD) system which enables the real-time diagnosis of 849 faults [7].

The presented here EGR diagnostics methodology does not require direct access. The proposed system diagnoses many faults through a dedicated analysis of combustion engine vibrations. It would seem that the exhaust gas recirculation system has no effect on the (vibroacoustic) vibrations generated by the engine. However, it turns out that such diagnostics is possible.

A compression-ignition Volkswagen, 1.9 TDi engine was used for the tests. The engine is with direct injection effected by a system of injection units, a turbocharging system with adjustable charger guide blades and a turbocharging air cooling system, and an intercooler.

The engine performance specifications are as follows:

1. maximum power - 74 kW (101 KM) at 4000 rpm,
2. maximum torque - 250 Nm at 1900 rpm.

Fig. 3 shows the external performance of the tested engine.

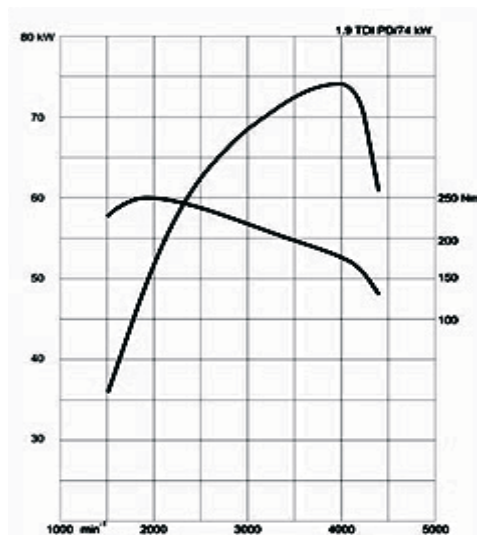

Fig. 3. Tested engine performance [14]

The engine test bench was equipped with a Ralpha 240 electrorotary brake made by AVL [8]. Its specifications are as follows [9]:

1. maximum power - 240 kW,
2. maximum torque - 600 Nm,

3. maximum speed - 10000 rpm,
4. inertia - $0.368 \frac{J}{kg * m^2}$.

The vibrations generated by the engine were measured by a scanning vibrometric system PSV made by Politec. The system includes:

1. a controller (OFV-5000),
2. a decoder module,
3. a vibrometric head (PSV400).

The vibration measurement parameters are shown in Tab. 1.

Tab. 1. Vibration measurement parameter

No.	Parameter	Value
1.	Kind of measurement	Speed vector
2.	Averaging	Off
3.	Number of samples	4096
4.	Sampling frequency	2048 Hz
5.	Measurement duration	2 s
6.	Filter	No
7.	Directivity	+Z
8.	Barrier frequency	20 kHz
9.	Vibration range	640 μ V/m

Fig. 4 shows the adopted diagnostic circuit.

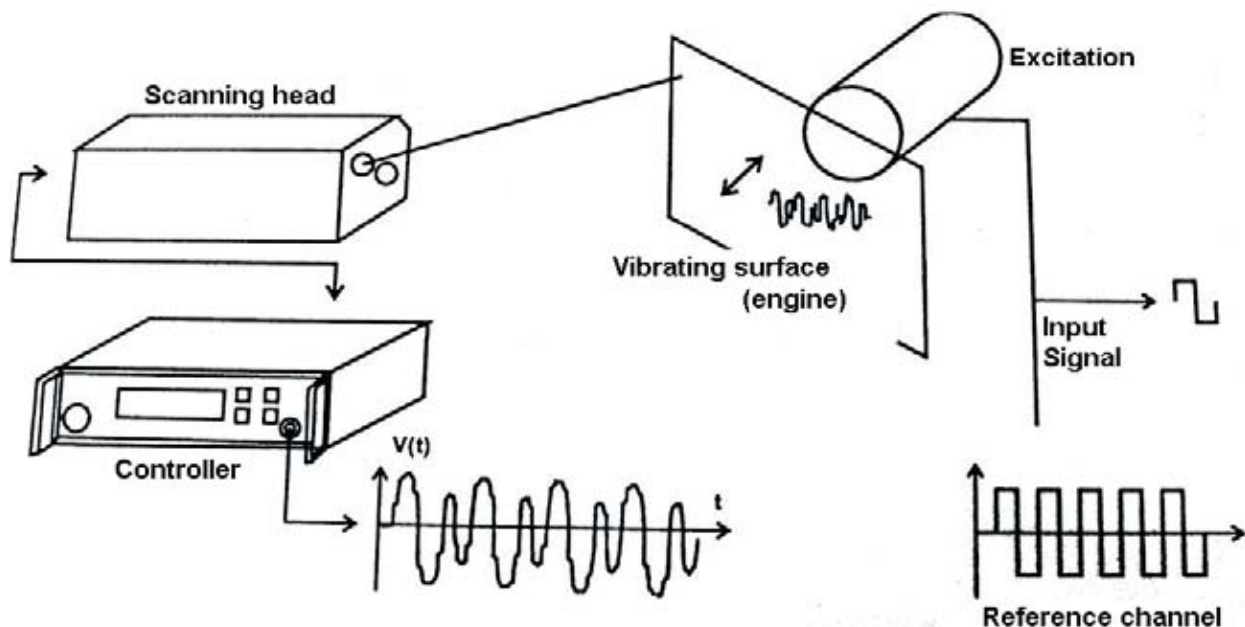

Fig. 4. Adopted diagnostic circuit

One should mention that it was not necessary to use a reference channel with a trigger arm in the investigations. This means that garage diagnostics without additional specialist equipment will be possible.

5. Digital processing of vibration signal

Without proper signal processing direct measurements do not yield explicit results. In addition, the proposed method requires multidimensional measurements, i.e. of a series of vibrations in the torque domain.

5.1. Operations on signal in time domain

The aim of all the signal digital processing operations performed during the investigations was to change the shape of the signal spectrum in a replicable way using standard methods. The first operation is signal windowing. In this case, windowing in the time domain since it is limited to the multiplication of the discrete vibration signal and the discrete window spectrum. Naturally, one could use a window in the frequency domain, but this would require the convolution of the two discrete signals.

A rectangular spectrum would have an ideal windowing sequence for damping uncharacteristic (from the investigation point of view) parts of the spectrum and simultaneously amplifying its characteristic parts. The ideal window would not distort the signal and prevent spectral leakage (an effect in which a part of the signal component, not situated by the frequencies for which the analysis is made, appears in all the output discrete signal values after transformation to the frequency domain [12]).

Since it is impossible to obtain a rectangular frequency characteristic a compromise is necessary. The compromise consists in the use of the best (from the investigation point of view) windowing sequence.

It has been experimentally found that a flap-top window is a good solution. This window is characterized by a low resolution at high dynamics [10]. Also its amplitude rendering accuracy is quite high. The values of this kind of window are calculated from the following formula (1) [10]:

$$\omega(t) = 1 - 1.93 \cos\left(\frac{2\pi t}{T}\right) + 1.29 \cos\left(\frac{4\pi t}{T}\right) - 0.388 \cos\left(\frac{6\pi t}{T}\right) + 0.0322 \cos\left(\frac{8\pi t}{T}\right), \quad (2)$$

where: $0 \leq t \leq T$ and $\omega(t) = 0$ for values from outside the domain.

5.2. Transformation to frequency domain

After windowing the signal is transformed to the frequency domain, using the fast Fourier transform with a base of 2. The way in which the FFT algorithm is introduced has been known since 1965 and it is widely described in the literature [10-12]. The fast Fourier transform used for discrete signals is expressed as follows:

$$X(k) = \sum_{j=1}^N x(j) \omega_N^{(j-1)(k-1)}, \quad (3)$$

where: $\omega_N = \exp\left(\frac{-2\pi i}{N}\right)$; N - the number of samples, k - the current sample of the frequency domain, j - the current sample of the time domain.

Thanks to the algorithm the calculations can be significantly speeded up and a modern PC does the job in a few seconds.

5.3. Filtering in frequency domain. Remez algorithm

One of the features of the discrete signal after the Fourier transformation, i.e. the time domain shift theorem, was used in the investigations. It follows from the definition of the Fourier

transformation that a shift of the signal in the time domain by the value x is equivalent to multiplying the signal spectrum by the complex number $e^{-j\omega x}$ [13]. The multiplication result has no effect on the shift of the spectrum in the frequency domain. Generally, the dependence can be written as:

$$x(t - t_0) \xleftrightarrow{FFT} X(\omega)e^{-j\omega t_0}, \quad (4)$$

hence:

$$x(t - t_{01}) \xleftrightarrow{FFT} |X(\omega)| \quad (5)$$

and

$$x(t - t_{02}) \xleftrightarrow{FFT} |X(\omega)|. \quad (6)$$

The above feature, thanks to which after the Fourier transformation (FFT) the spectral module is insensitive to time sample shift (5), (6), forms the basis of the proposed diagnostic method. There is no need to search for the same measuring point in each sample, i.e. for the top dead centre (TDC).

Since the spectral module is insensitive to the shift a decision was made to use the finite pulse response (FPR) filter design method. It is a very popular method of designing filters (except phase filters) [11].

In order to obtain the current output signal sample, FPR filters use only the previous samples and the current sample, which shortens and simplifies the analysis. As a result the method is suitable for real diagnostic systems.

The low-pass filter generated by the Remez method (also called the Parks-McClellan method) was amplified.

Since the spectrum of the filter was characterized by considerable damping and low stability, the obtained filter samples were multiplied in the time domain by the Blackman window (7):

$$\omega(k + 1) = 0.42 - \cos(2\pi \frac{k}{N-1}) + 0.08 \cos(4\pi \frac{k}{N-1}), \quad (7)$$

where: N - the number of samples, k - the current sample.

The filter samples prepared in this way are multiplied in the time domain by the samples of the frequency spectrum of the vibrations generated by the engine. One should note that windowing and filtering are possible in both the time domain and the frequency domain. However, windowing in the frequency domain would require the convolution of the window frequency spectrum and the signal spectrum and the filtering in the time domain would also require the convolution of the filter time spectrum and the vibration signal spectrum. As a result of the additional transformations and the convolution, the method would become complicated. Therefore the particular operations were performed in their natural domains, i.e. windowing by multiplying the window and the signal in the time domain and filtering by multiplying the filter samples and the signal samples in the frequency domain. Regardless of the path taken, the two operations are equivalent.

6. Analysis of results

The digital signal processing operations were performed multidimensionally. This means that the digital signal processing operations described were performed for all the signals measured at different torques at a constant rotational speed.

In the first step, measurements were performed for the engine in good working order as the reference. The obtained characteristic is shown in Fig. 5.

Then the EGR system electrovalve (Fig. 3) was switched off and the vibrations generated by

the engine were measured again. The obtained signal was processed in the same way as previously. The result is shown in Fig. 6. The area in which considerable signal amplitude deviations are observed is circled.

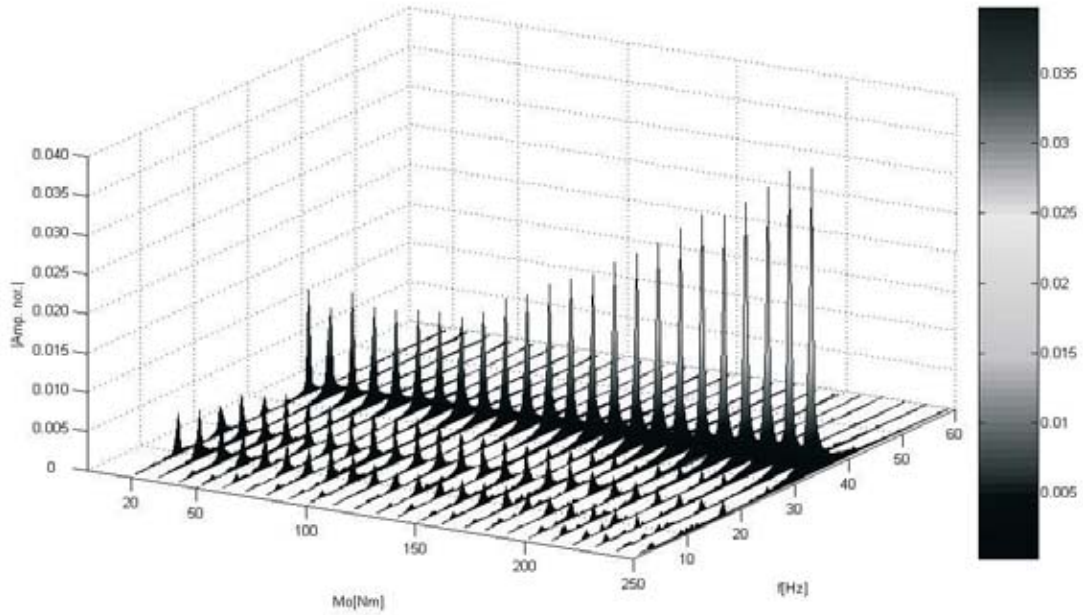

Fig. 5. Vibration versus torque spectrum of engine in good working order; $\omega = \text{const}$

One can notice that the function for the torque of 30 and 40 Nm has a different character. Moreover, the measurement is not fully replicable but characteristic for a given engine when the measurement methodology described here is used. The change here applies to a value of up to -3,5 dB.

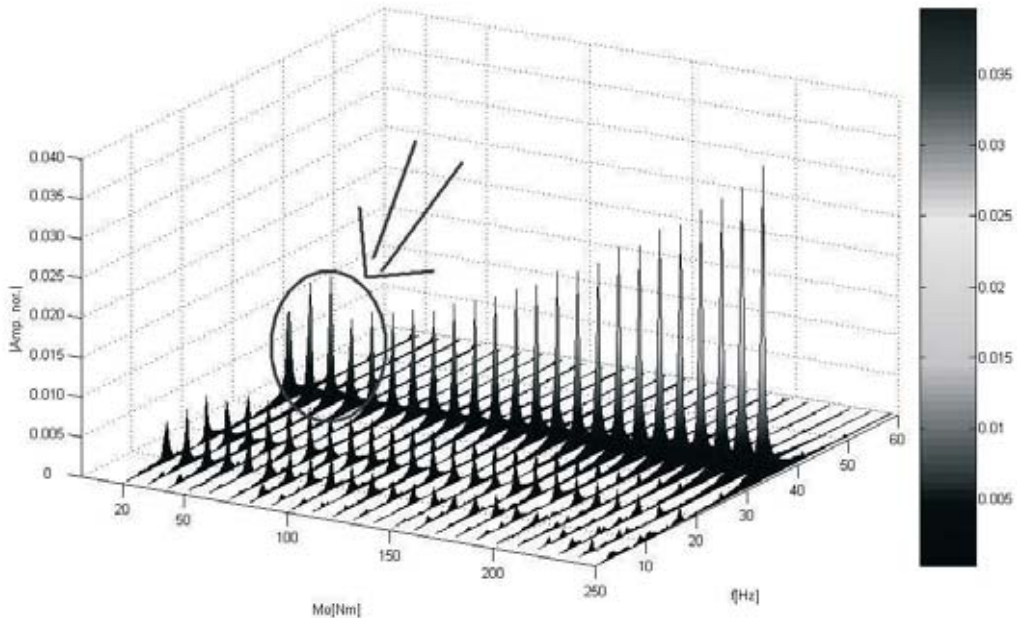

Fig. 6. Spectrum of vibration of engine with switched off EGR electrovalve versus torque; $\omega = \text{const}$

7. Conclusions

1. In vivo diagnostics of combustion engines, based on the analysis of vibration, is possible. It is desirable to use a laser device for this purpose.

2. Although the method is quite complex, particularly in its digital signal processing aspect, it can be implemented in the widely available diagnostic systems thanks to the increasing popularity of signal processors.
3. Several faults and failures which until now have been considered to have a negligible effect or no effect on the operation of the engine can be immediately detected on the basis of engine vibrations.
4. The multidimensional analysis of engine vibrations allows one to predict failures.
5. In the case of failures which clearly affect the vibrations generated by the engine, the onedimensional function is sufficient for this type of diagnostics.
6. The proposed method requires that measurements be performed for each model of the engine in good working order as the reference for further measurements. Measurements performed in accordance with the principles of digital processing of signals are replicable.
7. Engine vibrations are not an individual characteristic of each engine, but of the model.

8. References

- [1] *Engine Technology International* June 1999.
- [2] http://en.wikipedia.org/wiki/Exhaust_gas_recirculation.
- [3] <http://www.asashop.org/autoinc/nov97/gas.htm>.
- [4] <http://forum.tdi-tuning.pl/viewtopic.php?p=4267>.
- [5] Myszkowski, S., *Instalator Polski: Diagnostyka Pokładowa*.
- [6] http://60degreev6.com/index.php?title=Detailed_Sensor_Descriptions#Exhaust_Gas_Recirculation_Valve_28EGR.29.
- [7] Merkisz J., Mazurek S., *Pokładowe systemy diagnostyczne pojazdów samochodowych*, Wydawnictwa Komunikacji i Łączności, Warsaw 2002.
- [8] <http://www.avl.com>.
- [9] *The Thrill of Solution: Dynamometers and Drivers*, wyd. AVL, update 12.4.2001.
- [10] Stranneby D., *Cyfrowe przetwarzanie sygnałów. Metody, algorytmy, zastosowanie*, Wydawnictwo BTC, Warsaw 2004.
- [11] Zieliński T. P., *Cyfrowe przetwarzanie sygnałów*, Wydawnictwo WKŁ, Warsaw 2005.
- [12] Lyons R. G., *Wprowadzenie do cyfrowego przetwarzania sygnałów*, Wydawnictwo WKŁ, Warsaw 2006.
- [13] Szabatin J. *Podstawy teorii sygnałów*, Wydawnictwo WKŁ, Warsaw 2003.
- [14] <http://skoda.autokacik.pl/pages/chtyki/cha%20octavia.htm>.

"The author's reward was sponsored by Society of Collective Management of Copyrights of Creators of Scientific and Technical Works KOPIPOL with registered office in Kielce with duties obtained on the ground of the art. 20 and art. 20¹ of law on copyrights and related rights."

