

DRIVING STABILITY OF A VEHICLE WITH HIGH CENTRE OF GRAVITY DURING ROAD TESTS ON A CIRCULAR PATH AND SINGLE LANE-CHANGE

Kazimierz M. Romaniszyn

Technical University of Bielsko-Biala
Department of Combustion Engines and Vehicles
Willowa 2, 43-309 Bielsko-Biala
tel. +48 33 8279244, fax: +48 33 8279351
e-mail: kromaniszyn@ath.bielsko.pl

Abstract

Issues of driving stability of special-purpose vehicles result from engineering compromise between need of fulfilment of operational requirements and traction correctness of a vehicle. Especially, it concerns a motion in dynamic conditions with presence of high transverse accelerations. The paper comprises description and analysis of motion stability test results of a special-purpose two-axis vehicle with kerb mass of above 12 ton, with 4WD drive system, on a circular path drive and single line-change. One described methodology of the testing, used testing-measuring instrumentation, and distribution of the instrumentation in tested vehicle. It have been included a brief descriptions of the implemented instrumentation and method of acquisition and processing of the measurement data. One has tested a vehicle with highly located and considerably moved rearward centre of gravity. Such distribution of axle loads resulted from necessity of fulfilment of operational requirements of the vehicle. In the paper are presented test results performed for nominal and reduced with 20% tyre pressure. There were analyzed runs of lateral accelerations and axle slip angles in assumed condition of motion. One formulated general conclusions on stability characteristics for such type of vehicles.

Keywords: dynamics of vehicle motion, special-purpose vehicles

1. Introduction

Considerable part of motor trucks fleet driven on Polish roads is composed from vehicles, whose dynamic characteristics depend on type of superstructure assembled according to order of customers. Especially, it concerns such vehicles like: cisterns, fire ladders, operational fire engines, etc. Driving stability of such vehicles results from original features of a basic vehicle (in general chassis with cab and power transmission system) and distribution of masses and stiffness of assembled superstructure. Utility considerations, however, are decisive for the producer of the vehicle, who should comply with requirements of customers. To avoid occurrence of disadvantageous dynamic features of such vehicles, very often one limits their maximal speed and specially trains the drives.

In the present paper are described test results of two-axis, 4WD vehicle with highly-located and moved rearwards centre of gravity (an equal to about $2b$ with considerable value of c ; about 1.4 m). Marking of centre of gravity's position is shown in the Fig. 1. A factory-new vehicle after mileage of about 5000 km and having total weight slightly above 12 tons was used as object of the testing. The vehicle was equipped with suspension having multiple leaf springs and anti-roll bars, rigid driving axles and single wheels of the both axles. It can be assumed that in the analyzed case, proportional reduction of tyre pressure of the both axles should affect in a bigger lateral flexibility of tyres of heavier loaded axis, therefore the rear one.

Results presented in the paper were obtained by the author in result of testing work performed together with employees of the Academy of Technology and Humanities in Bielsko-Biala, Internal Combustion Engines and Automobiles Branch, on test track of the FIAT Auto Poland.

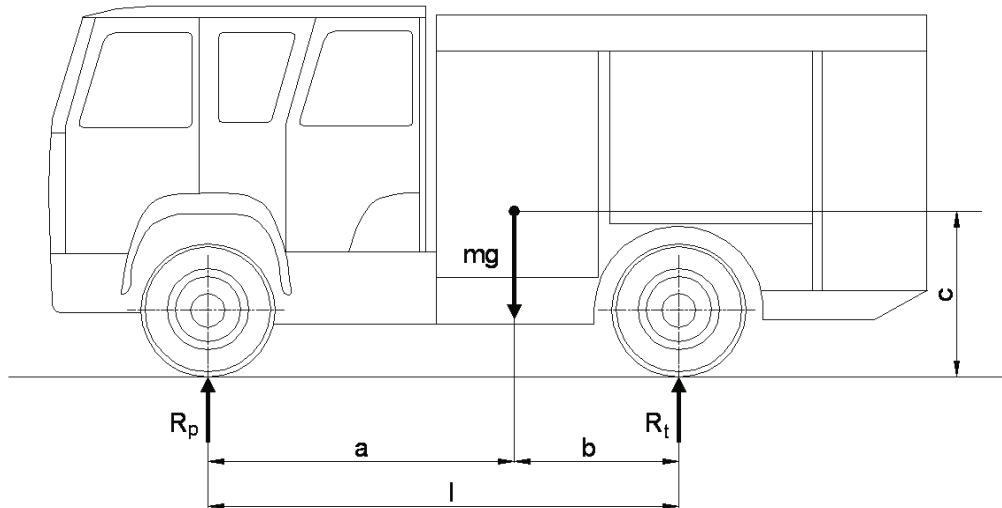

Fig. 1. Centre of gravity location coordinates of the tested vehicle

2. Description of the performed tests

Prior development of the program of traction tests one has made analysis of existing standards in that range, i.e. ISO: ISO-4138, ISO-7401, ISO-14791, ISO-14792, ISO-14793, and draft of Russian standard GOST P...2003, B32/03. Making selection of particular tests one followed required technical specifications of their accomplishment and possibility of good repeatability of measurements. In result, one decided to select two types of tests:

1. Test of single lane-change modelled after draft of Russian standard GOST P...2003, B32/03,
2. Circular path drive test with stepwise growing speeds modelled after ISO-4138 standard.

In the Fig. 2 are shown principal dimensions of the test track for the single line-change test, while in the Fig. 3 is shown view of measuring course to perform the tests. Fig. 4 shows accepted trajectory of motion of vehicle's centre of gravity during the circular path drive test.

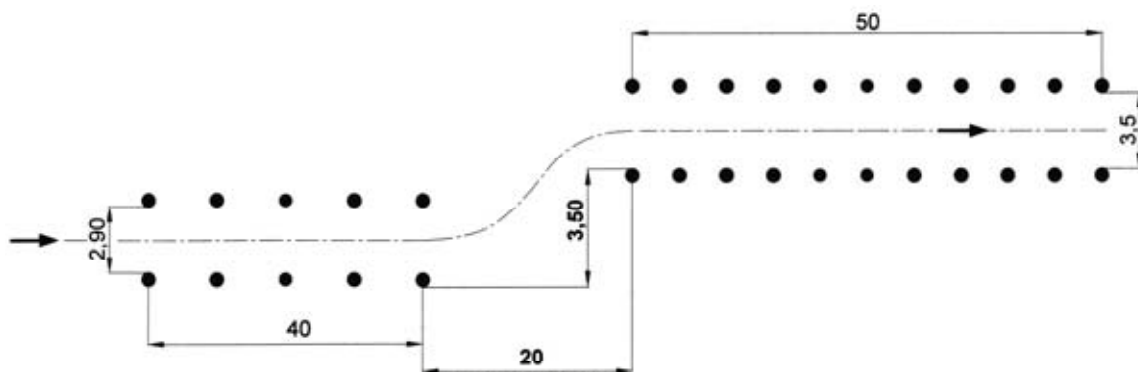

Fig. 2. Dimensions of the test course to single-lane change

Determination of limit speed of performance of the test was an important problem. In case of single line-change test, the speed was stepwise increased in each run, applying principle of decreasing speed gradients. In such way one obtained maximal speed possible to be obtained without displacement of the markers of the path. In case of circular path drive test, the observer stood near centre of the circle and observed drive of the vehicle with growing speed. Perceived commencement of losing adhesion of internal wheels, or considerable sideslip was assumed as base to signalling interruption of the test.



Fig. 3. View of the measuring track prepared to the testing as shown in the Fig. 2 (view from approaching side)

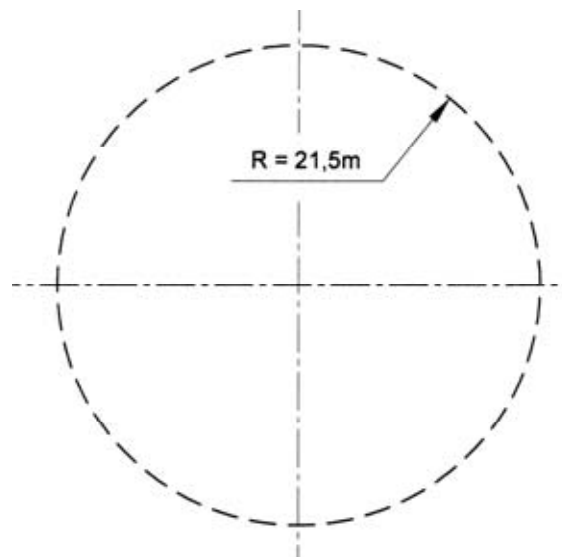

Fig. 4. Accepted trajectory of tested vehicle's centre of gravity motion during drive on circular path

3. Implemented measuring equipment

Tested vehicles were equipped with sensors and apparatus serving to registration and visualization of measured parameters (Fig. 5).

During drive of the vehicle were measured the following parameters:

- steering wheel torque (M_H) – measuring head (steering wheel) MSW- CORSYS-DATRON (Fig. 6),
- steering wheel angle (δ_H) – measuring head (steering wheel) MSW – CORSYS-DARTON,
- driving speed in direction of „X” axis (V_L) – Correvit SCE measuring head (Fig. 7),
- yaw velocity in direction of „Y” axis (V_Q) – Correvit SCE measuring head,
- yaw angular velocity of the body with respect to vertical axis „Z” ($\dot{\psi}$) – gyroscopic sensor CRS03-04 (Fig. 8),

- roll angular velocity of the body with respect to longitudinal axis „X” ($\dot{\phi}$) – gyroscopic sensor CRS03-02,
- yaw angular velocity of the frame with respect to vertical axis „Z” ($\dot{\psi}$) – gyroscopic sensor of aviation type (Fig. 9),
- roll angular velocity of the frame with respect to longitudinal axis „X” ($\dot{\phi}$) – gyroscopic sensor of aviation type.



Fig. 5. Apparatus to acquisition and visualization of measured parameters



Fig. 6. Measuring steering wheel



Fig. 7. Attachment of Correvit measuring head under centre of gravity

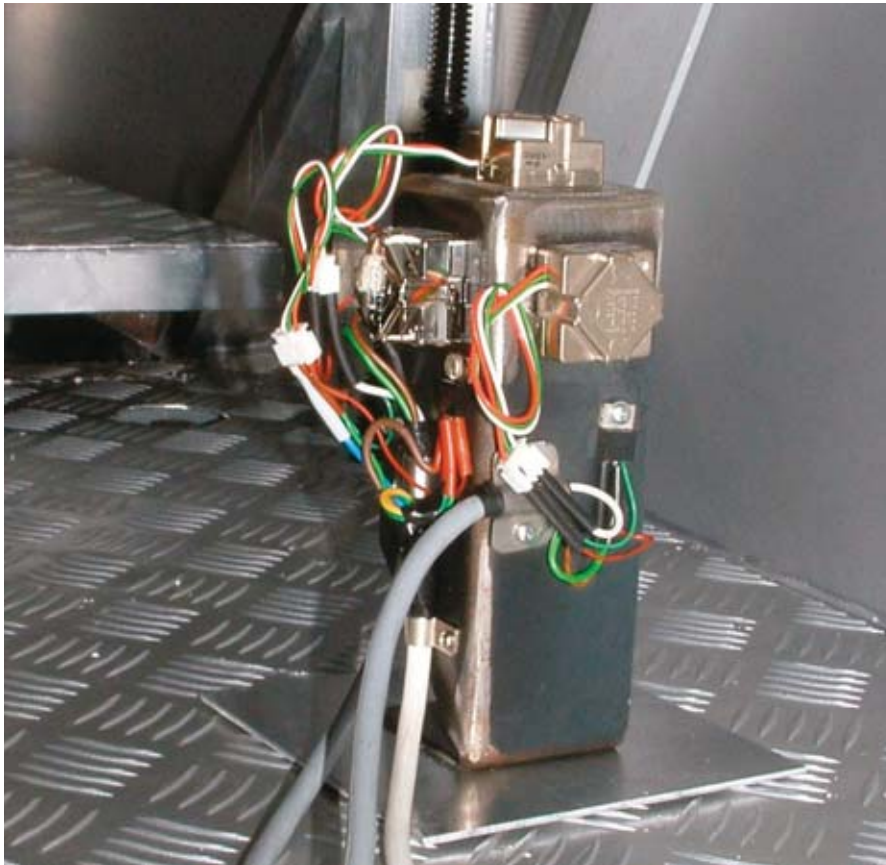

Fig. 8. Gyroscopic sensors of angular velocity of vehicle's body

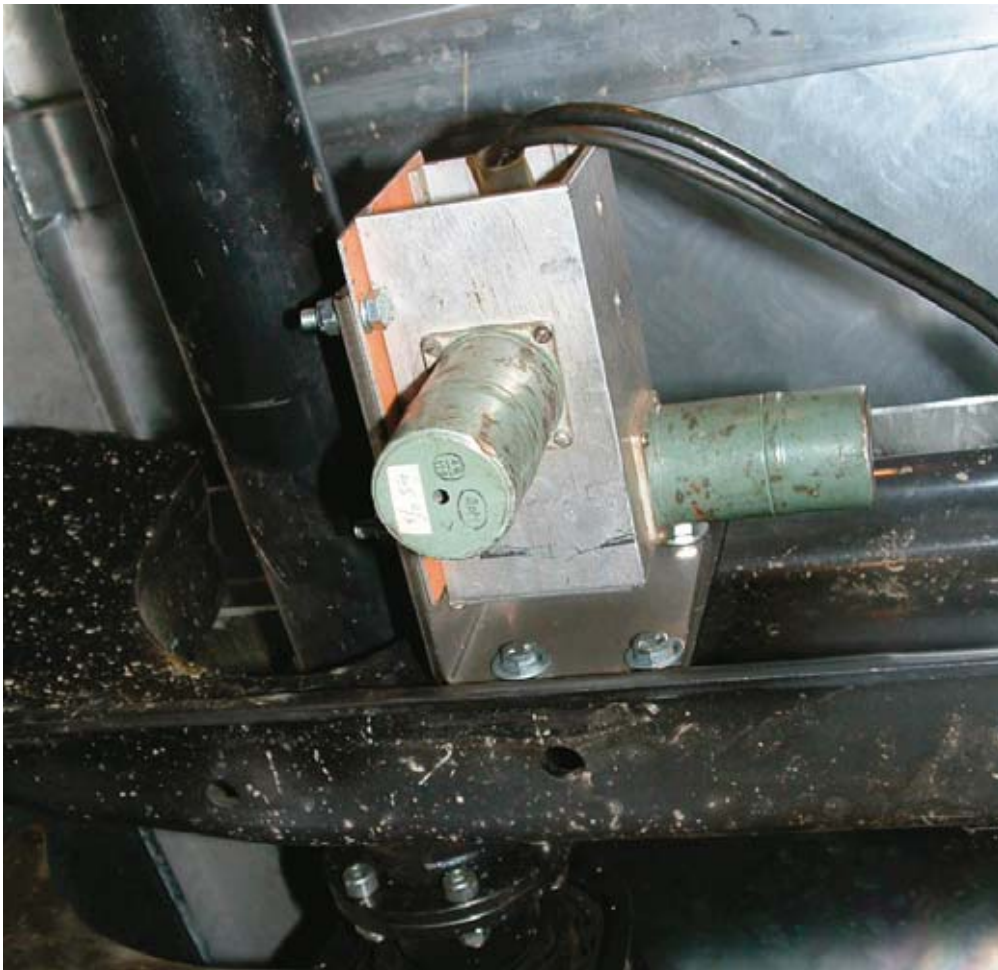

Fig. 9. Gyrosopic sensors of angular velocity of the frame

4. Results of traction tests of the vehicle

As already mentioned in previous chapters of the paper, the tests were performed for the single line-change and circular path drive with growing speeds. Each test was performed with repeated several times testing runs, while results presented here represent average from accomplished series of measurements. Below, due to size limit of the paper, are presented selected dependencies obtained from test results processed according to ISO 41388 standard. For the single lane-change, the runs shown in the Figs. 10 and 11 concern runs with maximal speeds.

4.1. Single line-change test

Single line-change test is classified among dynamic tests, in which are reflected features resulted from flexibility and damping capacity of elements which compose the whole of the vehicle. To such elements one can include, among others, stiffness and damping capacity of: tyres, suspensions, frame, superstructure and elements which connect these mentioned here. In the single lane-change test the main criterion of assessment is maximal speed of the vehicle without hitting poles which mark confines of the track, and shown in the Fig. 3. To assess dynamic features of the tested vehicles one recorded, among others, steering wheel angles and slip angles of axle's wheels, what is shown in the Figs. 10 and 11. Making assessment of the obtained results it should be remembered that time axis of the above mentioned diagrams is running from start-up time of the apparatus, whereas beginning of the maneuver should be taken as beginning of steering wheel's rotation.

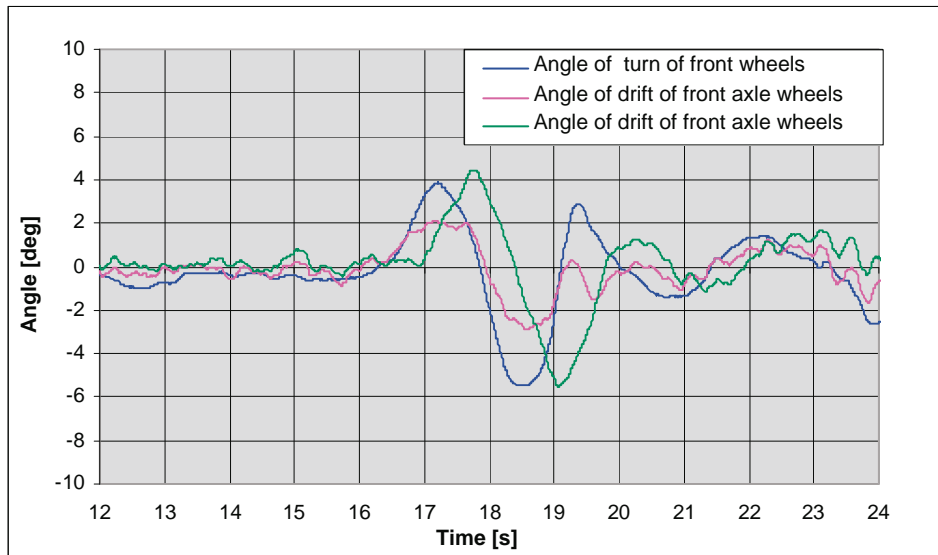

Fig. 10. Turn angles of the front wheels and slip angles of both axle wheels in single line-change tests on dry road surface and with nominal tyre pressure

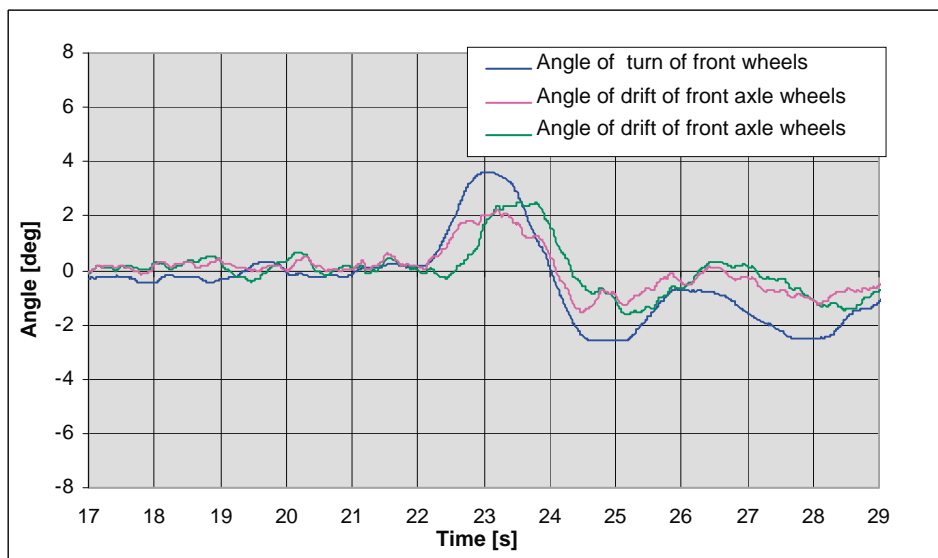

Fig. 11. Turn angles of the front wheels and slip angles of both axle wheels in single line-change test on dry road surface and with reduced tyre pressure

Making assessment of the recorded runs one can ascertain that, in the first part of the test, during the first 0.5-0.7 sec, slip angles of the front axle wheels were significantly bigger than the ones of the rear axle (LH turn). In the second phase of the test (RH turn) the slip angles of rear axle wheels were nearly twice bigger than slip angles of the front wheels for nominal tyre pressure (strong oversteer at departure from the test track). Differences between these angles decreased for reduced tyre pressure, while slip angles showed smaller values. For the tested vehicles there were obtained maximal cruising speeds: 51 km/h for nominal tyre pressure and 52 km/h for the reduced one. In course of the tests one measured torsional deflection of frontal part of the frame with respect to the rear part of the frame, result of that measurement amounted to 4.5° , what significantly affected dynamics of vehicle motion in the single line-change.

4.2. Circular path drive test

Circular path drive test was accomplished with cruising speed stepwise increasing up to speed for which there occurred losing adhesion of the rear internal wheel. For the tested vehicle such situation took place for the speed of 34.5 km/h in case of nominal tyre pressure, and 35 km/h for reduced tyre pressure. In course of the registered tests one maintained, to a certain degree, a constant turning angle of steered wheels, what is illustrated in the Figs. 12-15. Reported slip angles were obtained in quasi-stable conditions of motion with negligible small longitudinal accelerations. In the Figs. 12 and 13 is shown variability of turn angles of steered wheels and slip angles of the axle in function of time for nominal and reduced tyre pressure. In the successive Figs. 14 and 15 is shown a variability of these angles in function of lateral accelerations.

Time from beginning of registration to development of the maximal speed amounted to about 60 sec, while maximal attained lateral accelerations amounted to 4.25 m/s^2 for nominal tyre pressure and 4.40 m/s^2 for the reduced one.

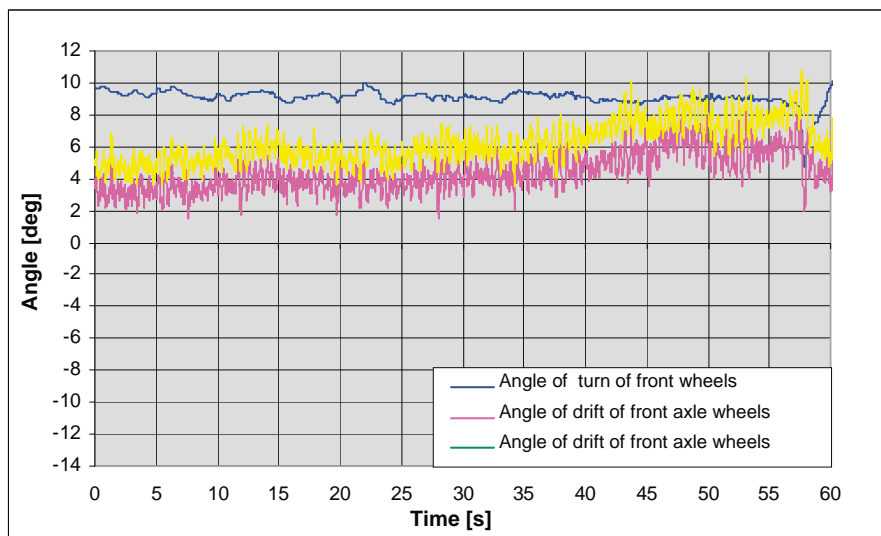

Fig. 12. Variability of angles: turn angle of front axle wheels and slip angle of the axle during circular path drive for nominal tyre pressure

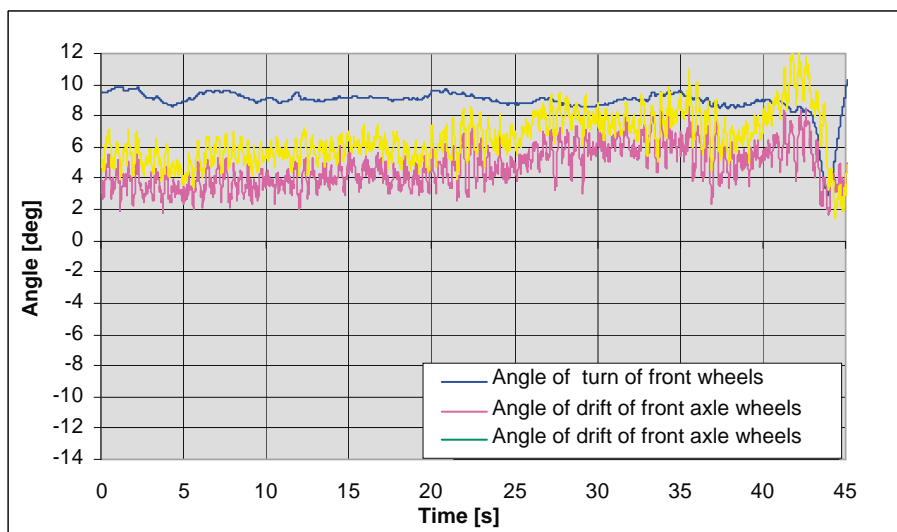

Fig. 13. Variability of angles: turn angle of the front wheels and slip angle during circular path drive for tyre pressure reduced with 20%

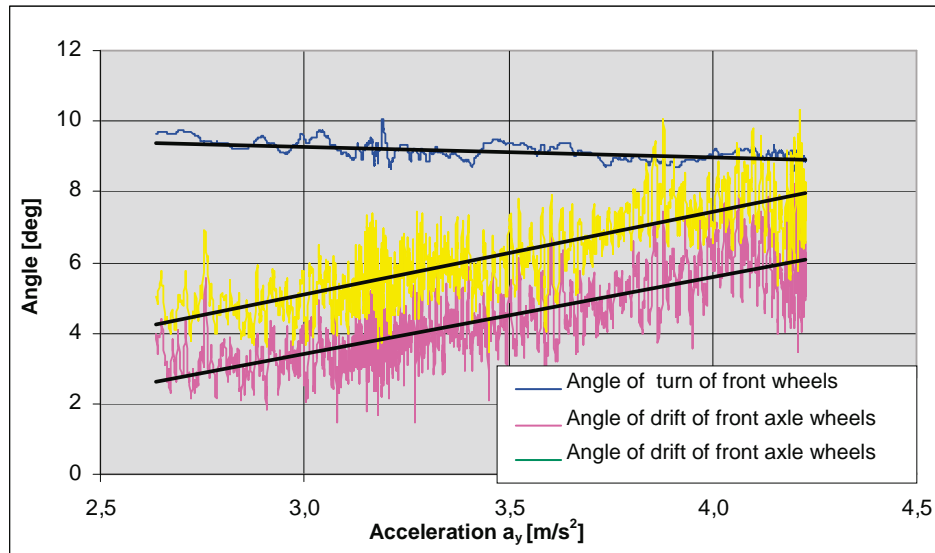

Fig. 14. Variability of turn angles of the front wheels and slip angles of the axle in function of lateral accelerations for nominal tyre pressure

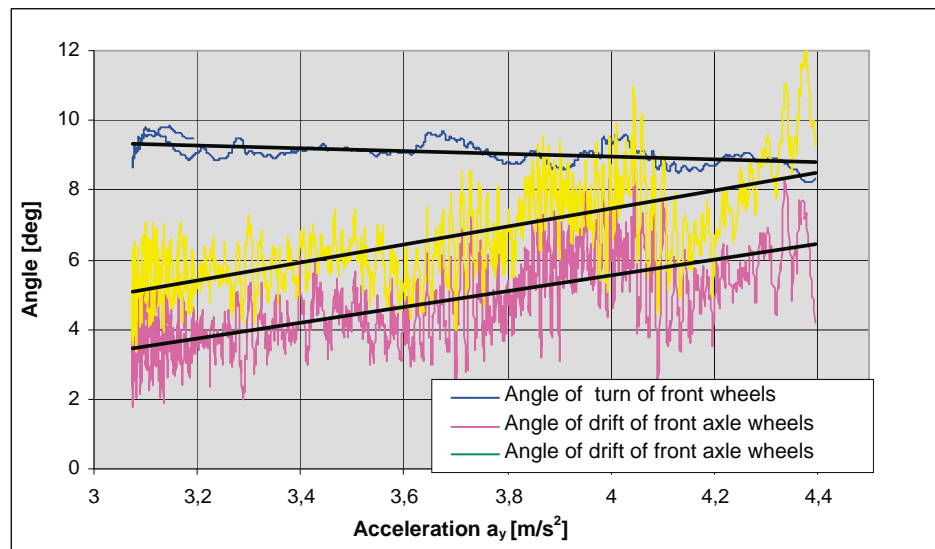

Fig. 15. Variability of turn angles of the front wheels and slip angles of the axle in function of lateral accelerations for tyre pressure reduced with 20%

Making assessment of the circular path drive test one can state that:

- For the nominal and reduced tyre pressure, slip angles of the rear axle wheels are significantly bigger than slip angles of front wheels (oversteer).
- To keep driving on the assumed circular path, together with growth of lateral accelerations (with about 0.5°), the driver should reduce turn angle of steered wheels.
- Both for the nominal and reduced tyre pressure, slip angles have similar values in function of the lateral accelerations, while differences between these angles are also similar.

5. Summary

Tested vehicle with highly located and moved rearwards centre of gravity features the following dynamic characteristics:

1. In the single line-change test, in the first phase of the test is present a strong understeer resulted from relatively small load of steered wheels. In the second phase of the tests, a

strong oversteer is also present resulted from considerable lateral forces acting on rear axle wheels. The same phenomenon is present in the first stage of RH turn.

2. Differences between slip angles of axle's wheels in the single line-change test with nominal tyre pressure reach value of 100% when their maxima are shifted in time from 0.5 to 1.0 sec.
3. Reduction of tyre pressure in the single line-change test results in equalization of slip angles of the axles with unchangeable time shifts of maxima of these angles.
4. During the circular path drive test is present a permanent oversteer resulted from difference between slip angles of the axles reaching value to about 2.0° .
5. During the circular path drive test, reduction of tyre pressure with 20 % does not effect significantly on measured dynamic features of the tested vehicle.

One can assume, that to improve dynamic characteristics of a vehicle with highly positioned centre of gravity, one should strive after modification of arrangement of space of superstructure in order to move, to a certain degree, forward the centre of gravity. It shall effect in more uniform distribution of lateral forces acting on wheels of the axles. Having defined architecture of superstructure, one should take care on correct relation between stiffness of suspensions of the both axles.