

THE PROGRAM OF EXPERIMENTAL RESEARCH REGARDING CONCENTRATION OF MAGNETIC PARTICLES Fe_3O_4 IN FERROFLUID FOR SLIDE JOURNAL BEARING LUBRICATION

Andrzej Miszczak, Marcin Frycz

Maritime University Gdynia, Faculty of Marine Engineering
Morska Street 83, 81-225 Gdynia, Poland
tel.: +48 58 6901348, +48 58 6901335, fax: +48 58 6901399
e-mail: miszczak@am.gdynia.pl, marcin.frycz@gazeta.pl

Abstract

This paper presents the project of the test stand to determine the friction force, the relative eccentricity and temperature distribution in the slide journal bearing during the lubrication with ferrofluid or classic oil. The test stand is built on the basis of TUM 25 lathe's corps. There is the shaft with a diameter of journal $d = 100$ mm supported on two supports attached to the lathe's body. There is a sleeve in the housing with the electromagnets installed in the centre of this shaft. The housing of sleeve is loaded by a transverse force with two hydrostatic supports (cylindrical and flat one). Measurement of friction force is made by strain gauge force sensor. Friction force is measured on the body shells. At the same time is performed measurement of both sleeve and journal displacements by four inductive displacement's sensors and four whirl-stream ones to determine the relative eccentricity and displacement of sleeve axis towards of the shaft axis.

The slide bearing is supplied by the ferrofluid which is thermally stabilized in ultrathermostat.

In the paper is shown particular plan for experimental research. These studies are intended to demonstrate the changes of relative eccentricity and temperature distribution in the bearing. Additionally are presented the changes of friction forces caused by the bearing surfaces shape and ferrolubricant with different concentrations of magnetic particles Fe_3O_4 . The gap of slide bearing can be affected by the external longitudinal magnetic field with different values of magnetic field strength. The bearing may be loaded a transverse force varying stepwise, or continuously with values from a few to several thousand Newton. Also, the rotational velocity of journal can be changed stepwise, or continuously from 0 to 6000 rpm using a programmable inverter.

Keywords: *ferrofluid, the position of the test bearings, measuring the force of friction, magnetic field, hydrostatic bearings, hydrodynamic bearings, temperature distribution*

1. Preliminary

The development of nanotechnology enables the production of ferromagnetic nano-particles based on iron oxide or gadolinium oxide, which started to be used as an additive for lubricating agents, sealants, or hydraulic fluids. These particles with a surfactant added to the considered factors enable to control the viscosity by an external magnetic field [2, 3, 6-8]. The constant magnetic field is used most often. The practical use of such fluids has already occurred in various types of actuators and hydraulic dampers, seals, loudspeakers and many other fields of science and technology including medicine and the arts [2, 3]. Research on the practical application of ferrofluids in journal bearings has been conducted sporadically. There are much more theoretical and numerical studies. Of course, friction nodes which can be applied by ferrofluid are limited both for the cost of such a node and ferrofluid as well as the possibility of constructing electromagnets within the body of relevant data devices. It is reasonable that the use of sliding friction pairs ferrofluid's lubricated only in such peaces where is a risk factor that classical fluid may fail or need to control in a wide range viscosity lubricant agent. The authors are talking about different types of machines and robots which are present in widely varying loads of the friction pair as well the space vehicles and equipment operating in a vacuum in the absence of gravity. Then generated by an external magnetic field of electromagnets or permanent magnets forced lubricating agent, fill the space lubricants.

The purpose of this study is to discuss the construction of the test stand and test program of journal bearing ferrofluid lubrication. As a lubrication factor to be applied lubricant mineral oil SAE 15W40 grade surfactant additives and magnetic particles at different concentrations for different conditions of load and journal rotational velocity.

2. The construction of the test stand

The position of the test bearings is built on the basis of body turning TUM 25, see Fig. 1. There will be attached to the body of turning a removable shaft with a journal diameter $d = 100$ mm. Depending on the type of research the shaft will be made of steel or non-magnetic material (bronze, brass). The shaft is supported on two supports with tapered roller bearings so that you can eliminate as much of lateral clearance. On the left side of the shaft is mounted sprocket gear cooperating with a toothed belt. By changing the gears can be set in the range of initial speed. The second gear wheel is mounted on the inverter-controlled electric motor. Using this device can be possible continuously adjustable speed cage, or can be programmed with an appropriate cage movement. It is installed a cup plain bearing in the housing in the middle of the shaft between the piers. All the elements of bearing are made of non-magnetic material. The sleeve is installed inside a solenoid coils and that are powered by direct or alternating current. Such a solution will make able to control the value and possibly the frequency of external magnetic field.

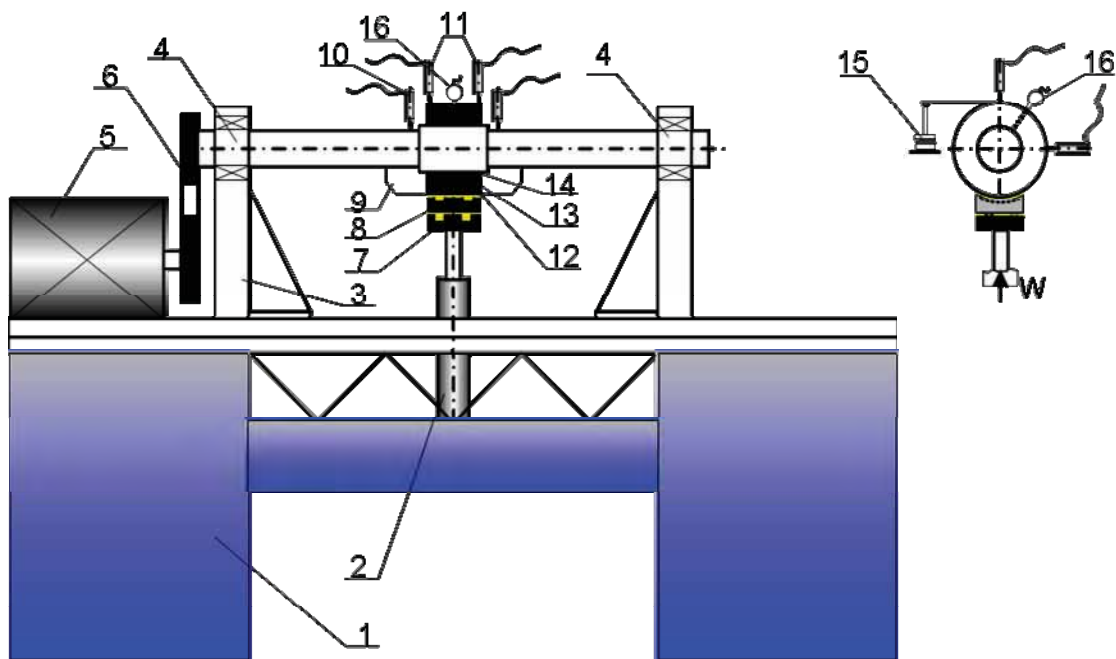

Fig. 1. Diagram of the stand for testing slide bearings: 1 – body turning TUM 25, 2 – hydraulic servomotor, 3 – the shaft's support, 4 – tapered roller bearing, 5 – electric motor, 6 – belt-gear transmission, 7 – flat hydrostatic bearing, 8 – cylindrical hydrostatic bearing, 9 – shell, 10 – eddy-current displacement shaft's sensor, 11 – inductive displacement sleeve's sensor, 12 – slide bearing shell, 13 – solenoid coil, 14 – sleeve, 15 – tens metric force sensor, 16 – pressure transducer

There are 4 inductive displacement sensors in contact with the shells (see Fig. 1 and 2) which make able to measure the displacement of sleeve in cover to the nearest $1 \mu\text{m}$. Journal displacement is determined on the basis of 4 installed eddy-current sensors. With this solution it is possible to designate the relative eccentricity and skew of sleeve axis to the shaft axis. In order to find a reference point for measuring the displacement relieves the plain bearing, oil supplies at a high temperature and sets the maximum possible velocity. Then the centre of the sleeve is set virtually in the middle of journal.

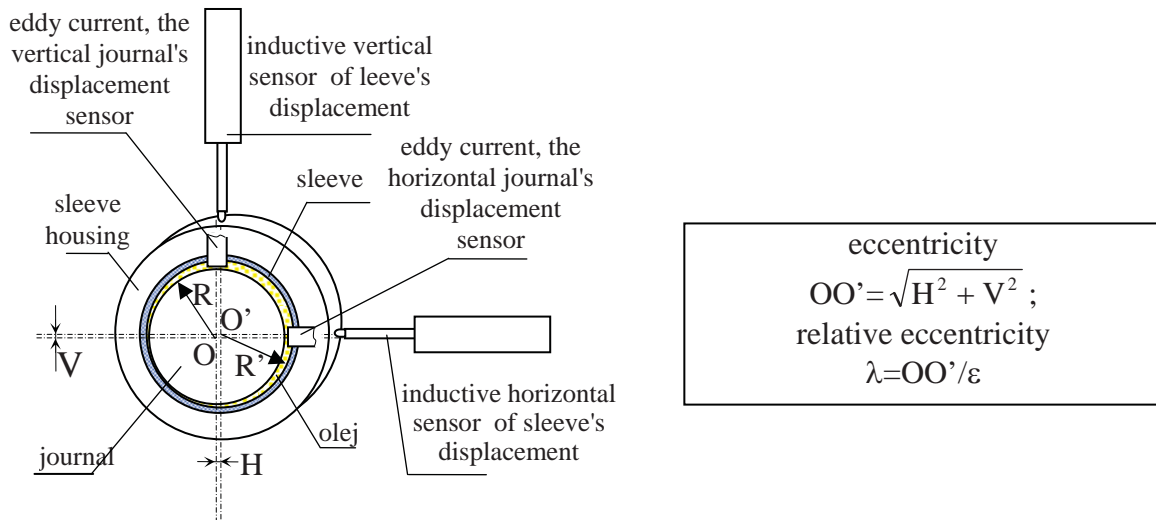

Fig. 2. Sketch of the measurement system to determine the relative eccentricity: O – journal centre, O' – centre of the sleeve, R – radius of the journal, R' – radius of the sleeve, $\varepsilon = R' - R$ – radial clearance

The load transmitted by the actuator and two hydrostatic supports is carried to the sleeve shells from bottom side. By using that kind of load's transfer makes the sleeve to move freely and substantially eliminates interference in the measurement of force or a moment of friction on the pan.

It is the tens metric force sensor with the transmitter installed to the sleeve's housing. In this way the friction force is recorded on the pan resulting mainly from the friction in the bearing.

The test stand is equipped with two independent hydraulic systems consisting of oil pumps and valves with pressure gauges. The first system has the task assigned to the hydraulic actuator and hydrostatic bearings. The second system is intended to provide a lubricating agent under appropriate pressure and temperature to the test slide bearing.

There are going to be optionally installed the Pt100 miniature temperature sensors or the pressure sensors near to the highest hydrodynamic pressure place.

In order to experimentally determinate temperature distribution on the sleeve's slide surface it will be equipped with dozens Pt100 micro sensors as it's showed in Fig. 3. In that way it gains the temperature distribution measurement.

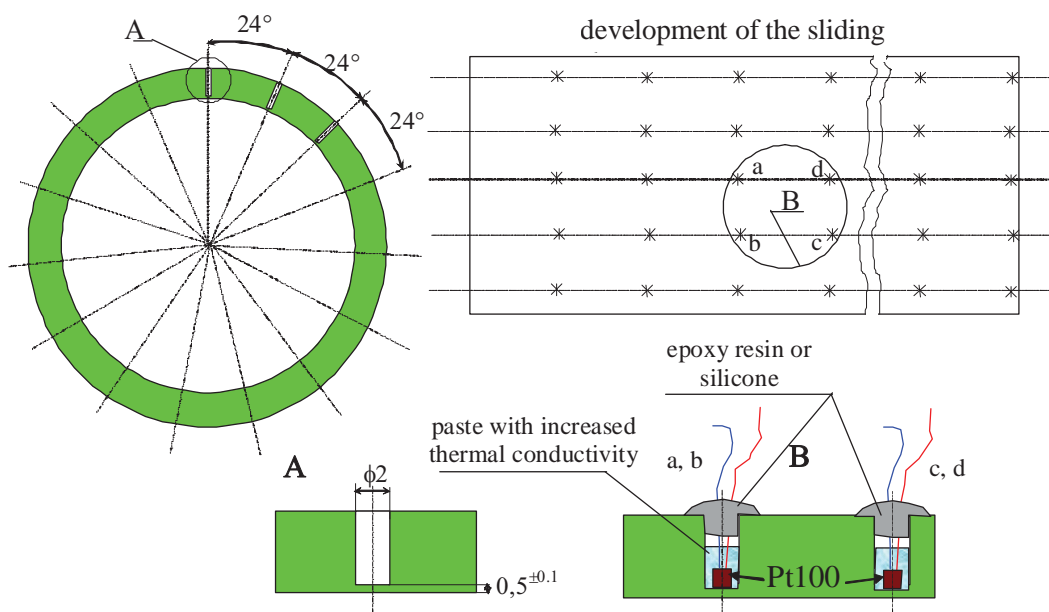

Fig. 3. Deployment diagram of Pt100 temperature sensors on the perimeter of the sleeve

Registration of the indications displacement sensors, friction and temperature, is implemented on a computer using Catman program and 100-channel measuring amplifier UPM100 produced by Hottinger Baldwin Messtechnik. That device can measure the standard voltage and current signals, measure temperature by thermocouples and resistance sensors such as Pt100, and measure the strain gauges.

To measure the friction force was used the tens metric force sensor with the transmitter KT 1400/K/200N/2410D (Fig. 1, pos. 15). The sensor is powered by a constant voltage with a value of 24 V, while the output signal voltage is 0-10 V corresponding to the strength of 0-200 N.

3. Research plan

On a test bearings is scheduled execution of experimental research related to the determination of the influence of external magnetic field and the concentration of magnetic particles on the operational performances and flow-transverse sliding bearings ferrofluid-lubricated.

The value of external magnetic field is measured at the inner surface of the sleeve without mounted of journal, using a magnetic field meter "Smart Magnetic Sensor" model SMS 102 by ASONIK. By using this meter can be measured both fixed and variable magnetic field. After completion of the characteristics of the magnetic field as a function of voltage and current supply solenoid coil, while experimental, will be made on changing the external magnetic field using a voltage and current settings on the adapter. After a series of testing and verifying the repeatability of results, it's planned researching for following volumes of magnetic particles in the base oil: 8%, 6%, 4%, 3%, 2%, 1%. That will be performed in a test's series for each volume for which will appropriately vary the load and journal velocity maintaining constant the other parameters of the bearing as ferrofluid's flow pressure and average temperature of the sleeve.

It will be applied Pennzoil LongLife Gold SAE 15W-40 mineral oil as the base oil.

Measurements were performed for shells with a length of 80 mm. That will be used thick shells of brass such as by SKF for testing.

It's very important to ensure that the test stand is properly temperature-stabilized during testing. In order to achieve such a state should bask test stand by maintaining high-speed of journal while the load bearing strength of about 1000 N for about 1 hour time.

Measuring the temperature distribution in the inner surface of the sleeve ferrofluid-oiled with different values of magnetic field and concentrations of magnetic particles will be made for the parameters given in Tab. 1.

Tab. 1. Ranges of parameter's values of bearing performance when measuring the inside surface shells temperature distribution a length of 80 mm

Applied force	Speed of rotation			
1000 N	1000 rpm	2000 rpm	3000 rpm	4000 rpm
2000 N	1000 rpm	2000 rpm	3000 rpm	4000 rpm
3000 N	1000 rpm	2000 rpm	3000 rpm	4000 rpm
Oil inflow temperature 80°C, Pressure in the flow 0.20 MPa				

Measurements of friction and hydrodynamic pressure will be made for the performance of the bearings shown in the Tab. 2.

Friction, hydrodynamic pressure at one point, the relative eccentricity and temperature of the inner surface of the sleeve should be measured after stabilization of the working conditions of the bearings. In order to ensure the accuracy of the experimental results and analysis of measurement errors need to register a sufficiently large series of results. From these measurements to designate the average values and standard deviations.

Tab. 2. Ranges of parameter's ranges of bearing performance when measuring friction and hydrodynamic pressure

1. The variable force applied to the bearing, the variable force loading bearing, 3 fixed rotary velocity of the journal						
Load force	Pressure	Sleeve temp.	Speed of rotation of the journal			
0-4000 N every 100N	0.2 MPa	80°C	1000 rpm	2000 rpm	3000 rpm	
2. Variable rotary velocity of the journal, set 4 forces applied to the bearing						
Speed of rotation of the journal	Pressure	Sleeve temp.	Applied force			
0-4000 rpm every 200 rpm	0.2 MPa	80°C	1000 N	2000 N	3000 N	4000 N

4. Summary

Presented the test stand is being constructed at the Department of Fundamentals of Technology Faculty of Mechanical Engineering, Gdynia Maritime Academy. Its construction follows from the thoughts and discussions that the authors had with the similar test stands creators.

Implementation of experimental research on the test stand which provides similar conditions to real work allows making appropriate measurements and interprets them correctly.

The results of experimental studies will serve to verify the sizes designated using analytical-numerical methods.

The obtained experimental results will determine the value of optimal concentrations of magnetic particles in ferrofluid at a specific value of the external magnetic field.

References

- [1] Korewa, W., Zygmunt, K., *Podstawy konstrukcji maszyn, cz. I i II*, WNT, Warszawa 1971.
- [2] Miszczak, A., *Tribologiczne i eksploatacyjne zastosowanie ferrocieczy*. IX Kongres Eksploatacji Urządzeń Technicznych, materiały konferencyjne, ss. 171-178, Krynica 2001.
- [3] Miszczak, A., *Analiza hydrodynamicznego smarowania ferrocieczą poprzecznych łożysk ślizgowych*, Monografia. Fundacja Rozwoju Akademii Morskiej, Gdynia 2006.
- [4] Miszczak, A., Wierzcholski, K., *Przebudowa testera T-05 jako stanowiska do wyznaczania lepkości oleju*, Zeszyty Naukowe Katedry Mechaniki Stosowanej, Politechnika Śląska, Vol. 14, ss. 105-109, 2000.
- [5] Miszczak, A., Wierzcholski, K., *Zmiany konstrukcji stanowiska badawczego T-05 do pomiaru siły tarcia w łożysku ślizgowym*, Problemy Eksploatacji, Nr 3 (38), pp.173-182, 2000.
- [6] Odenbach, S., *Ferrofluids – magnetically controlled suspensions*, Elsevier, Colloids and Surfaces A, Vol. 217, pp.171-178, 2003.
- [7] Rosensweig, R. E., Elborai, S., Lee, S.-H., Zahn, M., *Ferrofluid meniscus in a horizontal or vertical magnetic field*, Elsevier, Journal of Magnetism and Magnetic Materials, Vol. 289, pp. 192-195, 2005.
- [8] Rosensweig, R. E., *Ferrohydrodynamics*, Dover Publications INC, Mineola, New York 1997.