

Determination of the geometry function for a brachytherapy seed, comparing MCNP results with TG-43U1 analytical approximations

Gholamreza Raisali,
Maryam G. Ghonchehnazi,
Parvaneh Shokrani,
Mahdi Sadeghi

Abstract. Geometry function is the only dosimetry parameter of a brachytherapy source seed, introduced in TG-43U1 protocol which is determined using calculational methods rather than physical measurement. In order to evaluate the accuracy of point and line source approximations, for calculation of the geometry function, the MCNP computer code has been used for a typical brachytherapy seed and the results have been compared. The MCNP has been used to simulate the geometry and activity distribution of a Pd-103 seed in order to calculate the geometry function for various angles and distances from the source. The comparison of results shows that at distances close to the source, the values predicted with different methods are not in agreement. The difference between the MCNP calculations and line approximation for small angles from $\theta = 0$ to 15° is about 27% at 0.25 cm from the seed center. This difference is so much higher for point source approximation (up to a factor of 3) even up to distances of 0.5 cm from the source. As θ increases, the difference between MCNP and approximate methods is reduced. Therefore, for small distances from brachytherapy seeds, it is recommended to calculate the geometry function using more detailed methods instead of point and linear source approximations. This will provide more accurate results for other TG-43U1 dosimetry parameters such as radial dose function or anisotropy function which for some points are calculated via interpolation or extrapolation of the available discrete dosimetry data.

Key words: analytical approximation • brachytherapy • geometry function • MCNP • TG-43U1

G. Raisali✉
Radiation Applications Research School,
Nuclear Science and Technology Research Institute,
Atomic Energy Organization of Iran,
End of Kargare Shomali Str.,
P. O. Box 11365-3486, Tehran, Iran,
Tel.: +9821 88221222, Fax: +9821 88221219,
E-mail: graisali@aeoi.org.ir

M. G. Ghonchehnazi, P. Shokrani
Department of Medical Physics,
School of Medicine,
Isfahan University of Medical Sciences,
Hezar Jarib Str., Isfahan, Iran

M. Sadeghi
Agricultural, Medical and Industrial Research School,
Nuclear Science and Technology Research Institute,
Atomic Energy Organization of Iran,
Moazen Boulevard, Tahghighat Str., Karaj, Iran

Received: 5 July 2007
Accepted: 26 February 2008

Introduction

Brachytherapy is more extensively employed today for treatment of cancers involving eye, head and neck, breast, cervix and especially prostate for which interstitial techniques are being used. This increase is mainly due to the benefits such as the simplicity of the implementation of the treatment and less side effects, compared to external beam therapy and surgery. In permanent implant interstitial brachytherapy, low energy photon emitting source seeds (in cylindrical geometry) are embedded in tumor tissue [1, 5–9]. Dose distributions around cylindrical seeds are considerably asymmetric and for the purpose of treatment planning, it is necessary to accurately identify the dose distribution around the source [3, 11]. According to the AAPM TG-43U1 protocol [10], the necessary dosimetry parameters for brachytherapy sources include: air-kerma strength (S_k), dose-rate constant (Λ), geometry function ($G(r, \theta)$), radial dose function ($g(r)$) and anisotropy function ($F(r, \theta)$). These parameters are integrated in Eq. (1) to calculate spatial dose distribution, $\dot{D}(r, \theta)$, according to the coordinate system shown in Fig. 1.

$$(1) \quad \dot{D}(r, \theta) = S_k \Lambda \frac{G_X(r, \theta)}{G_X(r_0, \theta_0)} g_X(r) F(r, \theta)$$

where $X = P$ for point-source approximation and $X = L$ for line-source approximation.

$$(2) \quad S_K = \dot{K}(d) \cdot d^2$$

$$(3) \quad \Lambda = \frac{\dot{D}(r_0, \theta_0)}{S_K}$$

$$(4a) \quad G_P = (r, \theta) = r^{-2}$$

$$(4b) \quad G_L(r, \theta) = \begin{cases} \frac{\beta}{Lr \sin \theta} & \text{if } \theta \neq 0^\circ \\ (r^2 - L^2/4)^{-1} & \text{if } \theta = 0^\circ \end{cases}$$

$$(5) \quad g_x(r) = \frac{\dot{D}(r, \theta_0) \cdot G_X(r_0, \theta_0)}{\dot{D}(r_0, \theta_0) \cdot G_X(r, \theta_0)}$$

$$(6) \quad F(r, \theta) = \frac{\dot{D}(r, \theta) \cdot G_X(r, \theta_0)}{\dot{D}(r, \theta_0) \cdot G_X(r, \theta)}$$

where L , r , β , and θ are the parameters shown in the coordinate system used for brachytherapy dosimetry calculations (Fig. 1). In Equation (2), d is the calibration distance; $\dot{K}(d)$ is the air kerma rate at distance d from the source center on the transverse plane. In dose calculations, the reference point is selected at $r_0 = 1$ cm, on the transverse axis bisecting the source ($\theta = 90^\circ$). According to TG-43U1 protocol, the geometry function takes into account the effect of the distribution of the radioactive material inside the source.

Accuracy in the calculation of the geometry function yields accuracy in the interpolation and extrapolation of the radial dose and anisotropy functions [10]. However, this function is the only dosimetry parameter in TG-43U1 protocol which is determined through calculations rather than physical measurements. In this research the geometry function of the first Pd-103 seed (NRCAM01) manufactured at Iranian Agricultural, Medical and Industrial Research School (AMIRS) has been calculated using the MCNP computer code and the results are compared with the values calculated using the analytical methods mentioned in TG-43U1.

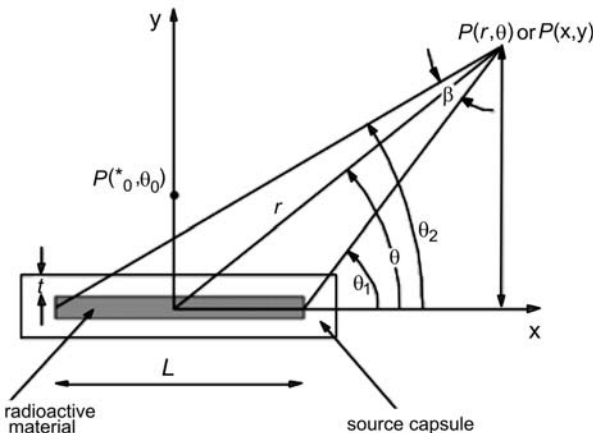

Fig. 1. Coordinate system used for brachytherapy dosimetry calculations [10].

Materials and methods

Source description

The Pd-103 seed used in this research (NRCAM01) is a cylindrical tube made of titanium with an internal diameter of 0.7 mm and external diameter of 0.8 mm. The physical length of the tube is 4.5 mm and weld thickness at each end is 0.1 mm. The seed includes 4 resin beads, each having a diameter of 0.6 mm with Pd-103 uniformly absorbed inside. NRCAM01 also contains a cylindrical copper marker, having a height of 1.5 mm and diameter of 0.6 mm, located at the center of the seed. Schematic diagram of the source is shown in Fig. 2. According to TG-43U1 protocol, the active length of the seed is considered as the distance between proximal and distal aspects of the activity distribution which is 3.9 mm for NRCAM01.

Calculation methods for geometry function

Analytical calculations

According to the AAPM's TG-43U1 protocol, for point source approximation, the activity distribution is considered as a dimensionless point with an isotropic dose distribution around the source, therefore the geometry function $G_P(r, \theta)$ is calculated from Eq. (4a). In line source approximation, however radioactivity is assumed to be uniformly distributed along a one dimensional line-segment with active length L . The geometry function is calculated using Eq. (4b) where β is the angle subtended by the tips of the hypothetical line source with respect to the calculation point, $P(r, \theta)$, and is calculated using Eq. (7).

$$(7) \quad \beta = \theta_2 - \theta_1 = \tan^{-1} \left(\frac{x+L/2}{y} \right) - \tan^{-1} \left(\frac{x-L/2}{y} \right)$$

where $x = r \cdot \cos \theta$, and $y = r \cdot \sin \theta$.

Calculations using MCNP computer code

Usually, the geometry function, even for sources with complex geometries, is calculated according to point or line approximation. In this research, using the capability of MCNP code [2] for simulation of complex geometries, we have applied it to calculate the geometry

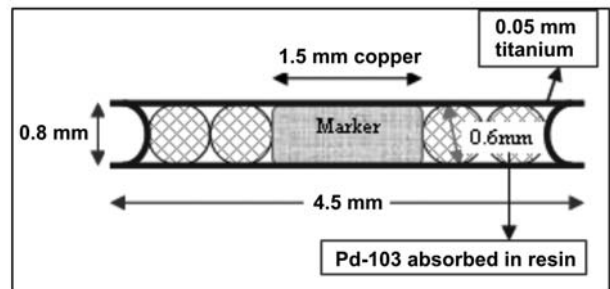

Fig. 2. Schematic diagram of the Pd-103 seed used in this research.

function for the seed “NRCAM01”. The seed geometry was simulated as shown in Fig. 2. The geometry function has been determined using tally F4 at different distances and several angles with respect to the source longitudinal axis. The medium inside and around the seed has been considered as vacuum in order to disregard the absorption and scattering in the seed and the surrounding media, therefore purely representing the effect of the activity distribution and inverse square law.

Results and discussion

Geometry function values for the first Pd-103 seed manufactured at AMIRS (NRCAM01) have been calculated analytically and by MCNP at various distances from the source and for angles $\theta = 0^\circ$ to 30° and $\theta = 45^\circ$ to 90° . The results are shown in Table 1. The values are normalized to $G(1\text{ cm}, \pi/2)$ [4, 9]. To compare the results calculated with different methods, the behavior of the geometry function for several angles vs. distance from the seed center are demonstrated in Figs. 3–8. The results for angles 15° and 30° have been observed to be nearly the same as those calculated for 45° , therefore not presented.

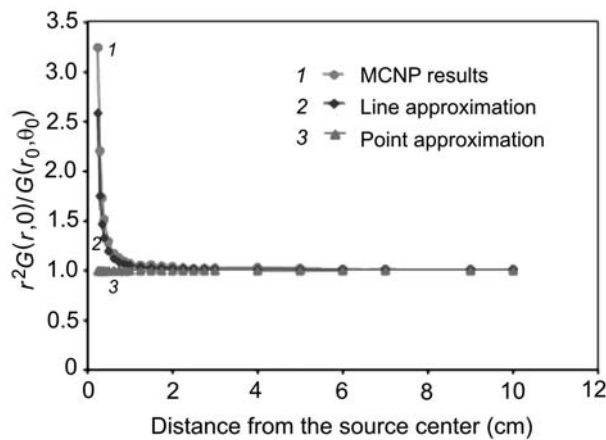

Fig. 3. Calculated values of $r^2G(r, 0)/G(r_0, \theta_0)$ using analytical methods with point approximations and line approximations and by MCNP computer code.

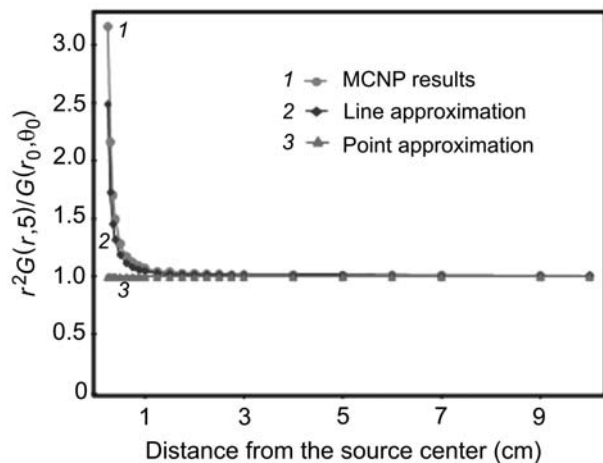

Fig. 4. Calculated values of $r^2G(r, 5)/G(r_0, \theta_0)$ using analytical methods with point approximations and line approximations and by MCNP computer code.

It is seen that at distances close to the source, the values predicted by MCNP calculations are not in agreement with the results obtained from the point and line source approximations. For the line approximation, the maximum difference belong to the $\theta = 0$ to 15° .

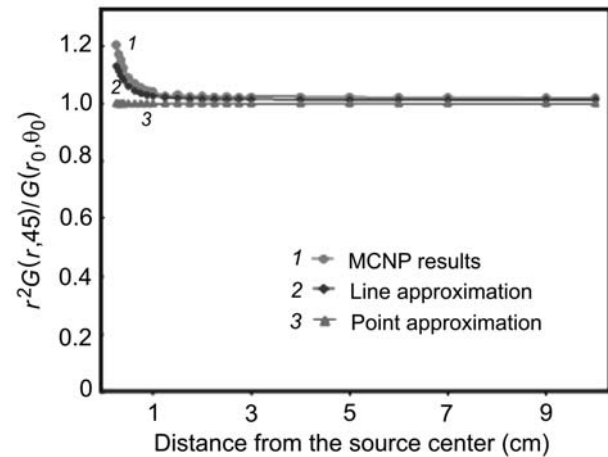

Fig. 5. Calculated values of $r^2G(r, 45)/G(r_0, \theta_0)$ using analytical methods with point approximations and line approximations and by MCNP computer code.

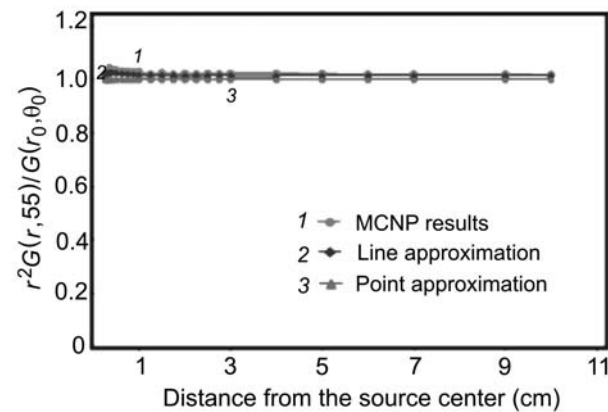

Fig. 6. Calculated values of $r^2G(r, 55)/G(r_0, \theta_0)$ using analytical methods with point approximations and line approximations and by MCNP computer code.

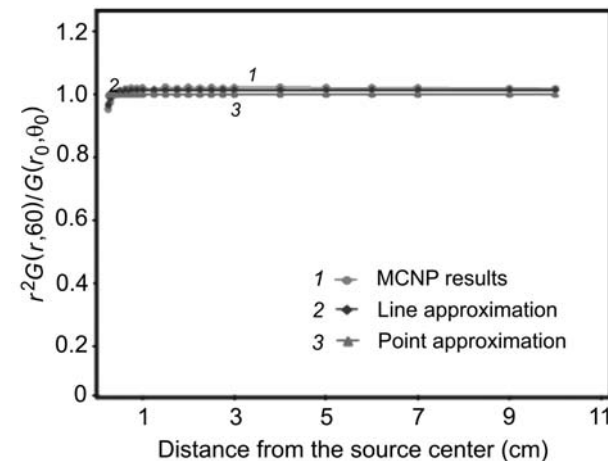

Fig. 7. Calculated values of $r^2G(r, 60)/G(r_0, \theta_0)$ using analytical methods with point approximations and line approximations and by MCNP computer code.

Table 1. Normalized geometry function for the first Pd-103 seed manufactured at AMIRS [$r^2 G(r, \theta)/G(r_0, \theta_0)$]*

r (cm)	$\theta = 0^\circ$		$\theta = 5^\circ$		$\theta = 15^\circ$		$\theta = 30^\circ$		$\theta = 45^\circ$		$\theta = 55^\circ$		$\theta = 60^\circ$		$\theta = 90^\circ$	
	line	MCNP	line	MCNP	line	MCNP	line	MCNP	line	MCNP	line	MCNP	line	MCNP	line	MCNP
0.250	2.586	3.245	2.489	3.158	2.008	2.547	1.435	1.691	1.129	1.202	1.009	1.017	0.966	0.952	0.860	0.793
0.300	1.753	2.206	1.731	2.163	1.587	1.926	1.315	1.491	1.112	1.170	1.021	1.028	0.987	0.974	0.898	0.8403
0.350	1.468	1.734	1.459	1.705	1.391	1.594	1.235	1.365	1.095	1.150	1.025	1.041	0.998	1.000	0.924	0.887
0.400	1.328	1.517	1.323	1.498	1.283	1.435	1.182	1.280	1.080	1.123	1.025	1.037	1.003	1.004	0.932	0.911
0.500	1.194	1.293	1.192	1.288	1.157	1.233	1.119	1.183	1.059	1.089	1.023	1.034	1.008	1.011	0.957	0.946
0.750	1.121	1.126	1.085	1.127	1.078	1.122	1.059	1.092	1.034	1.054	1.018	1.029	1.012	1.019	0.991	0.987
0.875	1.086	1.093	1.065	1.096	1.060	1.095	1.046	1.073	1.029	1.044	1.017	1.027	1.012	1.018	0.996	0.994
1.000	1.065	1.072	1.052	1.077	1.049	1.078	1.038	1.062	1.025	1.040	1.016	1.028	1.012	1.019	1.000	1.000
1.250	1.053	1.056	1.037	1.048	1.035	1.051	1.029	1.038	1.020	1.025	1.015	1.018	1.012	1.013	1.004	1.000
1.500	1.038	1.060	1.030	1.044	1.028	1.047	1.024	1.037	1.018	1.030	1.014	1.024	1.012	1.022	1.007	1.013
1.750	1.030	1.045	1.025	1.032	1.024	1.037	1.021	1.028	1.017	1.023	1.014	1.018	1.012	1.017	1.009	1.012
2.000	1.025	1.042	1.022	1.031	1.021	1.036	1.019	1.030	1.016	1.025	1.013	1.021	1.012	1.021	1.009	1.018
2.250	1.022	1.028	1.020	1.025	1.019	1.029	1.018	1.026	1.015	1.022	1.013	1.019	1.012	1.018	1.010	1.016
2.500	1.020	1.022	1.019	1.026	1.018	1.030	1.017	1.027	1.014	1.023	1.013	1.022	1.012	1.021	1.010	1.020
2.750	1.019	1.024	1.018	1.021	1.017	1.027	1.016	1.025	1.014	1.020	1.013	1.020	1.012	1.019	1.011	1.019
3.000	1.018	1.025	1.017	1.022	1.016	1.027	1.015	1.026	1.014	1.022	1.013	1.021	1.012	1.020	1.011	1.021
4.000	1.017	1.032	1.015	1.019	1.015	1.027	1.014	1.024	1.013	1.021	1.013	1.022	1.012	1.021	1.012	1.022
5.000	1.015	1.024	1.014	1.017	1.014	1.024	1.013	1.022	1.013	1.021	1.013	1.021	1.012	1.020	1.012	1.022
6.000	1.014	1.014	1.014	1.018	1.013	1.022	1.013	1.020	1.013	1.020	1.013	1.019	1.012	1.019	1.012	1.020
7.000	1.014	1.014	1.013	1.015	1.013	1.021	1.013	1.019	1.013	1.020	1.013	1.019	1.012	1.019	1.012	1.020
9.000	1.013	1.012	1.013	1.012	1.013	1.019	1.013	1.017	1.013	1.019	1.012	1.018	1.012	1.018	1.012	1.019
10.000	1.013	1.012	1.013	1.009	1.013	1.019	1.013	1.016	1.013	1.018	1.012	1.017	1.012	1.017	1.012	1.017

* Calculated values of [$r^2 G(r, \theta)/G(r_0, \theta_0)$] using analytical method with point approximations equals to one.

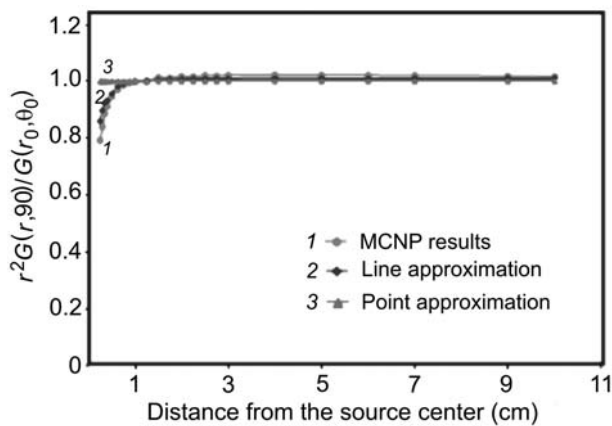

Fig. 8. Calculated values of $r^2G(r, 90)/G(r_0, \theta_0)$ using analytical methods with point approximations and line approximations and by MCNP computer code.

For example for these angles at 0.25 cm from the seed center which corresponds to a distance of 0.025 cm from the capsule wall, the MCNP calculations predicted a value which is 27% higher than the results of the line approximation. For the point approximation this difference is so much higher as can be seen in Table 1. At 0.25 cm from the seed center, as θ increases the difference between the results of MCNP calculation and line approximation is reduced to 18, 6 and 1% for $\theta = 30, 45$, and 55° , respectively. For the seed "NRCAM01" for angles of $\theta < 55^\circ$, the MCNP results are always higher and for angles of $\theta > 55^\circ$ lower than those derived analytically. It is worth mentioning that for $\theta = 55^\circ$, the difference between the three methods is less than 4%. The difference between the MCNP results and the line approximation is less than 1% for all distances from the source. This phenomenon is due to the activity gap inside the NRCAM01 seed which has a non active marker at the center and two active beads at each side of the marker. For distances of $r > 5$ cm, the differences for all angles are small ($< 1\%$), because at far distances, the seed behaves as a point source regardless of the method of calculation.

Conclusion

The disagreement between the MCNP predictions and the values derived from the point and line analytical approximations, shows that these approximations are not reliable for points close to the seed, especially for smaller angles. According to the TG-43U1, the distances less than 1.5 cm are very important in brachytherapy and the accuracy in predicting the values for geometry function

will increase the accuracy of other source parameters due to more accurate extrapolation and interpolation of the radial dose and anisotropic functions. This research showed that in order to calculate the geometry function of a brachytherapy seed more accurately, it is necessary to account the activity distribution inside the source using more detailed methods such as Monte Carlo calculations. Therefore, it is concluded that instead of using the approximate analytical approaches, more accurate methods or computer codes such as MCNP could be applied to calculate the geometry function with more detailed consideration of the activity distribution inside the source. This will provide more accurate results for other TG-43U1 dosimetry parameters such as radial dose function or anisotropy function which for some points are calculated via interpolation or extrapolation of the available discrete dosimetry data.

References

- Bernard S, Vynckier S (2005) Dosimetric study of a new polymer encapsulated Pd^{103} seed. *Phys Med Biol* 50:1493–1504
- Briesmeister JF (ed.) (2000) MCNP-4C – a general Monte Carlo N-particle transport code – Version 4C. LA-12625-M. Los Alamos National Laboratory
- Daskalov GM, Williamson JF (2001) Monte Carlo-aided dosimetry of the new Bebig IsoSeed Pd^{103} interstitial brachytherapy seed. *Med Phys* 28;10:2154–2161
- King RP, Anderson RS, Mills MD (2001) Geometry function of a linear brachytherapy source. *J Appl Clin Med Phys* 2;2:69–72
- Meigooni AS, Bharucha Z, Yoe-Sein M, Sowards K (2001) Dosimetric characteristics of the best double-wall Pd^{103} brachytherapy source. *Med Phys* 28;12:2568–2575
- Meigooni AS, Zhang H, Clark JR, Rachabathula V, Koona RA (2004) Dosimetric characteristics of the new RadioCoil™ Pd^{103} wire line source for use in permanent brachytherapy implants. *Med Phys* 31;11:3095–3105
- Patel NS, Chiu-Tsao S, Williamson JF *et al.* (2001) Thermoluminescent dosimetry of the Symmetra I^{125} model I25.S06 interstitial brachytherapy seed. *Med Phys* 28;8:1761–1769
- Reniers B, Vynckier S, Scalliet P (2002) Dosimetric study of a new palladium seed. *Appl Radiat Isot* 57:805–811
- Rivard MJ (2001) Monte Carlo calculation of AAPM Task Group Report No. 43 dosimetry parameters for the MED3636-A/M I^{125} source. *Med Phys* 28;4:629–637
- Rivard MJ, Coursey BM, DeWerd LA *et al.* (2004) Update of AAPM Task Group No. 43 Report: a revised AAPM protocol for brachytherapy dose calculations. *Med Phys* 31;3:633–674
- Weaver K (1998) Anisotropy functions of I^{125} and Pd^{103} sources. *Med Phys* 25;12:2271–2278