

POSSIBILITIES OF IMPROVING SAFETY AND RELIABILITY OF SHIP PROPULSION SYSTEM DURING DP OPERATIONS

Jerzy Herdzik

Gdynia Maritime University, Marine Power Plant Department
Morska Street 81-87, 81-225 Gdynia, Poland
tel.: +48 58 6901430, fax: +48 58 6901399
e-mail: georgher@am.gdynia.pl

Abstract

Improving safety and reliability of ship propulsion system during dynamic positioning (DP) operations of multipurpose vessels is an essential advantage. It may be such possibilities obtained by application the considered solutions of propulsion systems and all other elements of energetic system. The minimum requirements were determined by creating the regulations of dynamic positioning systems and their levels. Applying the solutions, which were exceeded the limits of basic requirements, allows to increase the safety and reliability levels with a low rise the investment costs. Many marine companies try to invent so low cost solutions. An example analysed in the paper is the Wartsila LCC system. The applications of more complicated solutions in comparison to required duplicated systems are expensive. The cheaper solution is an investing in the development of automatics configurations (for those systems it was applied the triple and quadruple configurations) which in transient or emergency conditions may obtain the time delay making possible a support of industry part work and DP systems. In emergency situation, after the loss of position by DP system, the power management system allow the safe break of work the industry part and return to work after elimination the critical condition.

Keywords: propulsion system, dynamic positioning operation, reliability, safety, propulsion system solutions

1. Initial remarks

One of the main challenges when design process of DP classed vessels is first to determine the optimum machinery and switchboard configuration. The next one is the optimum propulsion arrangement, number and types of thrusters, location of thrusters in the hull, their maximum power and thrust, especially the direction and resultant thrust of working thrusters [7]. The important one is a decision of total generator power for propulsion and the industry part, which is present on analysed vessel.

The boundary conditions for DP vessel most often is designed to operate in and survive extreme sea environmental conditions, although statistically these conditions occur very rarely. The DP vessel runs at median or lower power levels during the majority of operation.

For multi-mode ships, the propulsion system ought to be design at very small speed near zero with as big thrust as possible and with very good manoeuvring possibilities.

One of the challenges is a fulfilment of requirements determined by IMO and classification society's regulations with minimum investment costs. A conservative design philosophy must be used when designing a propulsion system intended for dynamic positioning. While the design objective for a conventional propulsion system places peak efficiency on or near the systems maximum continuous rating, a propulsion system designed for DP service should be selected and sized to meet the absolute survival requirements [5, 6, 9, 11].

For class 2 and 3, IMO requires an online consequence analysis during DP operation. This function must continually perform an analysis if the vessel's ability to maintain its position and heading (course) after a predefined single worst-case failure during operation. Possible consequences are based on the actual weather condition, enabled thrusters and power plant mode.

Typically worst-case failures are:

- failure in the most critical thruster,
- failure in one thruster group,
- failure in one switchboard section [2].

2. Propulsion arrangements and location

Improving safety and reliability of ship propulsion system during DP operations of multipurpose vessels is an essential advantage. Propulsion system solution, propulsion arrangement and its location are important problems during design and later in vessel operation. It must be remembered about some limits and restrictions. For example, there is a narrow limit of continuous bollard pull for different types of thrusters. It is presented in Tab. 1. Knowing the power delivered to the thruster it is possible to estimate the thrust and vice versa.

Tab. 1. Bollard pull for different thruster types [2]

Type of propulsion	Continuous bollard pull [N/kW]
Open propeller Azimuth thruster	130
Contra rotating Azimuth thruster	140
Azimuth thruster with nozzle	170
Tunnel thruster	123

An example of propulsion arrangement on typical offshore vessel was presented on Fig. 1. There are 6 main gensets and 2 emergency gensets plus stand-by genset for diving emergency operations. The propulsion system composes with 2 main propellers, 2 astern thrusters and 2 bow thrusters.

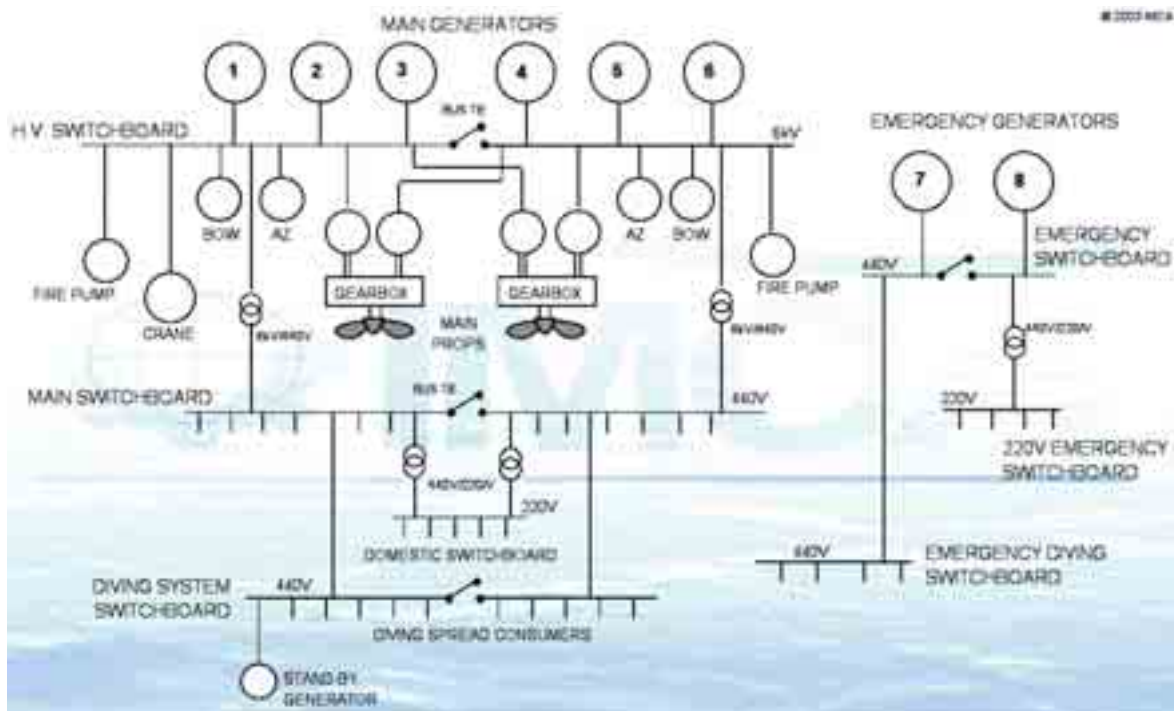

Fig. 1. Power distribution on typical offshore vessel [12]

The power plant is located in 2 engine rooms divided by watertight bulkhead. The main propellers are driven each by 2 electric motors powered from 2 independent sections of switchboard.

Propulsion for DP ships must provide thrust continuously and efficiently in ahead and astern directions of operation, (the best is in all around directions but is to satisfy a thrust vector command at 45 degrees). The propulsion solution with four thrusters or more is preferable for vessels with dynamic positioning system (cable ships, pipe-laying vessels, etc.).

3. Switchboard configuration

The switchboard configuration on DP vessels is often divided into 2 sections due to reliability reasons. An example of switchboard arrangement is presented on Fig. 2.

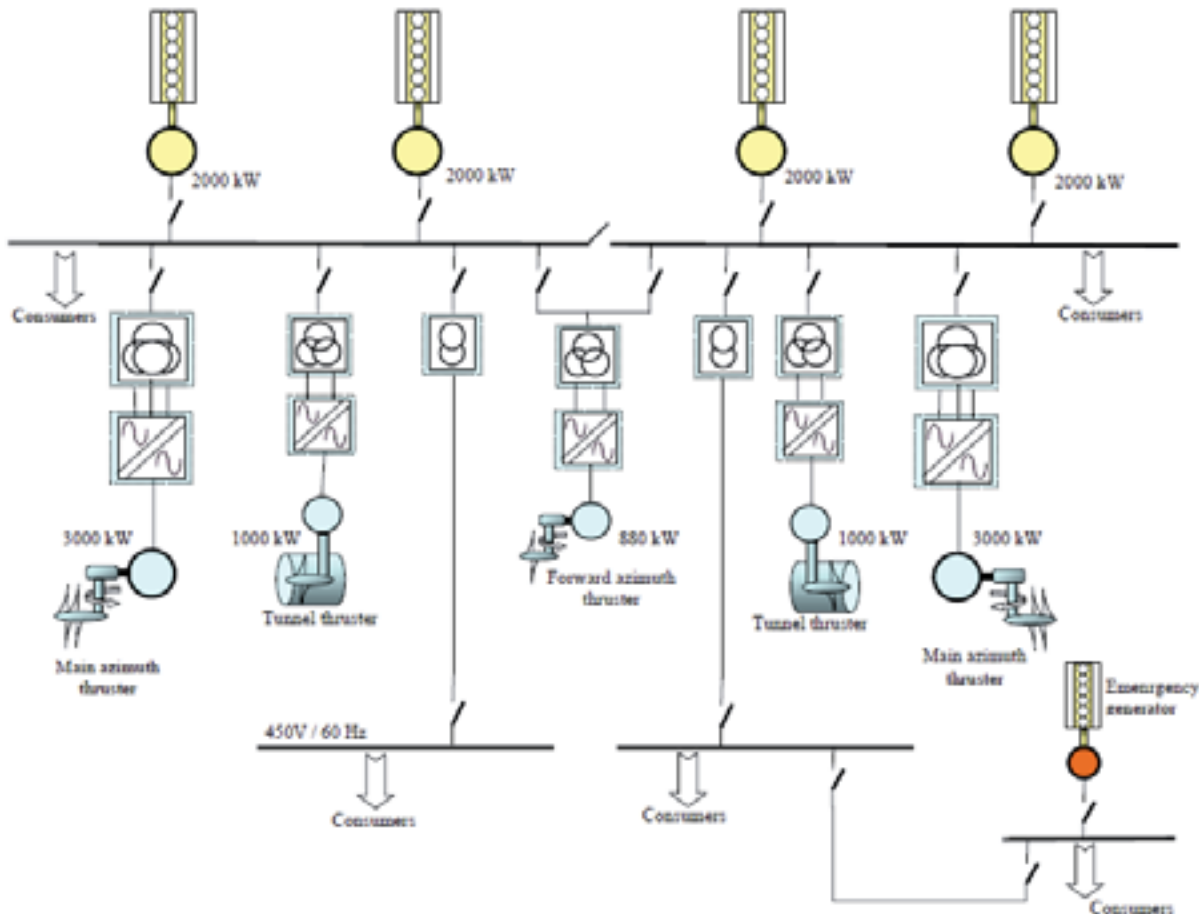

Fig. 2. Single line switchboard arrangement for DP vessel [4]

An oil and gas production vessel will have more power installed. The generation and distribution of power is split between several generators and switchboard units. The popular solution has 6-8 gensets, 4-split configuration of switchboard and 6-8 thrusters for propulsion.

A medium voltage main distribution system is typical 6kV, 6.6 kV or 11kV bus voltage. Main breakers have a capacity of 20-40 kA.

Large generation capacity may increase the short level above acceptable values. In these cases additional current limiting devices or restrictions in operation of connected switchgear units has been implemented [4]. This will give restrictions in how the bar-bar sections can be connected together. This will be controlled by the Power Management System (PMS). Typical PMS system for DP vessel is presented on Fig. 3 and the PMS topology on Fig. 4.

There are two independent PMS systems: PMS A and PMS B. This type of power generation and distribution arrangement is redundant and allows DP operation in many different failures if minimum one of two redundant elements is efficient.

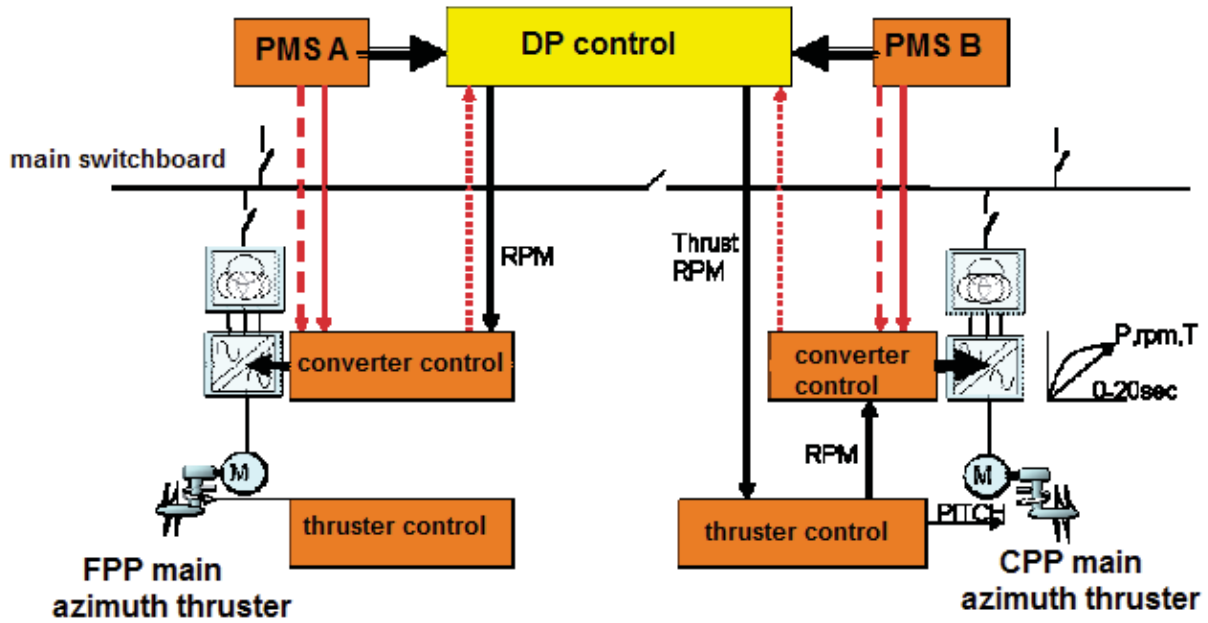

Fig. 3. Typical PMS system for DP vessel [4]

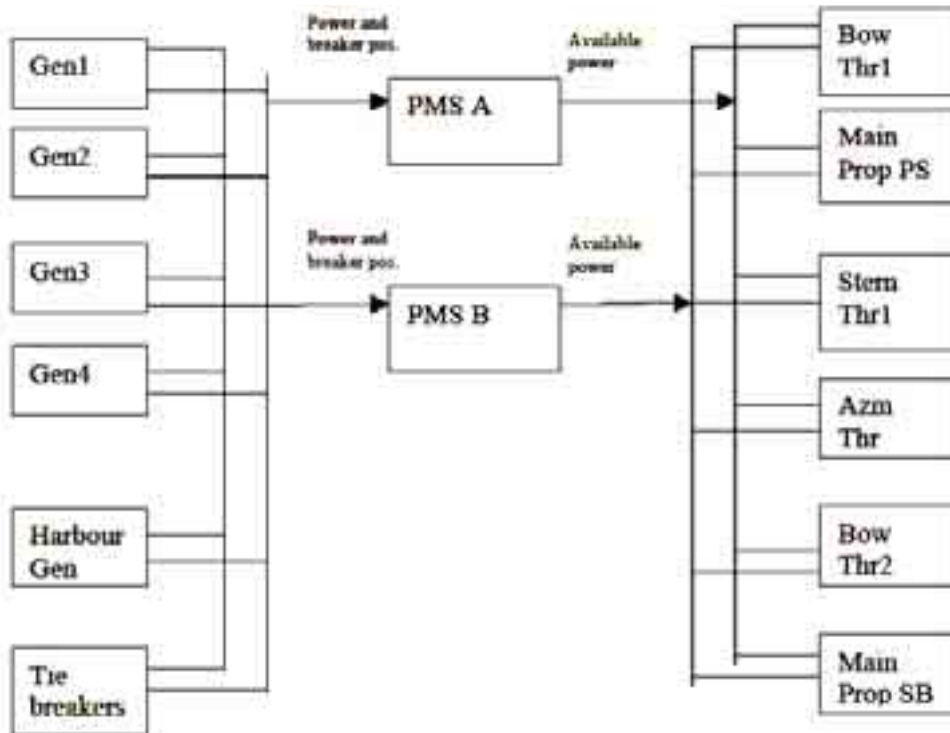

Fig. 4. PMS topology [4]

4. The Wartsila Low Loss Concept

In the Wartsila LCC [2], the switchboard is divided into four independent sections (Fig. 5). Every generator supplies one section of switchboard. Every thruster may be powered from one of two sections. The worst-case failure has been defined as loss of one switchboard section. Even in that case, about 75% of full thruster power is still available. All thrusters connected to the faulty switchboard section will still have 50% power from another section (the generator

power is divided into two thrusters). Using the ShipX Station Keeping program developed by Sintef-Marintek was calculated the equilibrium between mean environmental forces and maximum propeller and thrusters forces as a function of vessel heading. It was made an assumption of the environmental parameters: constant current speed of 1.5 knots and variable wind and wave drift forces.

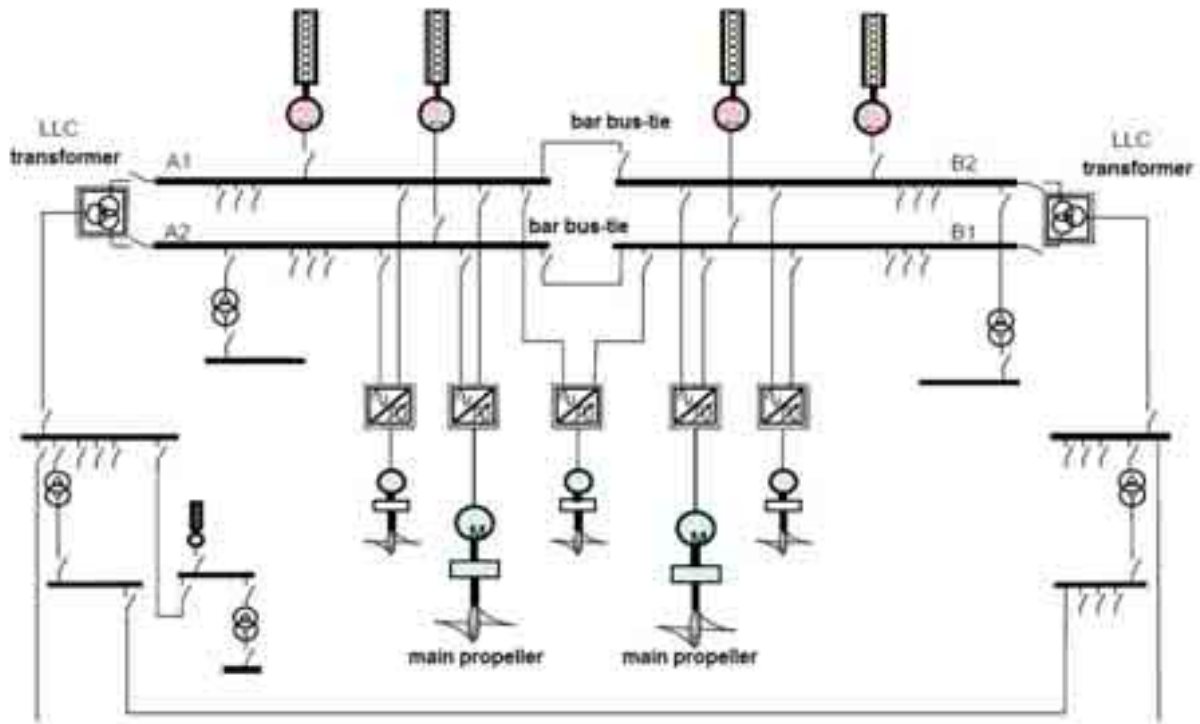

Fig. 5. Typical arrangement of Wartsila LLC [2]

The Wartsila proposition of LLC, realized as DP vessel on Gulf of Mexico, is presented on Fig. 6. There are 7 propeller/thrusters. The summary of propeller and thrusters forces with maximum available thrust is presented in Tab. 2. The maximum available thrust is come from the main propeller, which must controllable pitch propeller (CPP) due to station keeping operations as DP vessel.

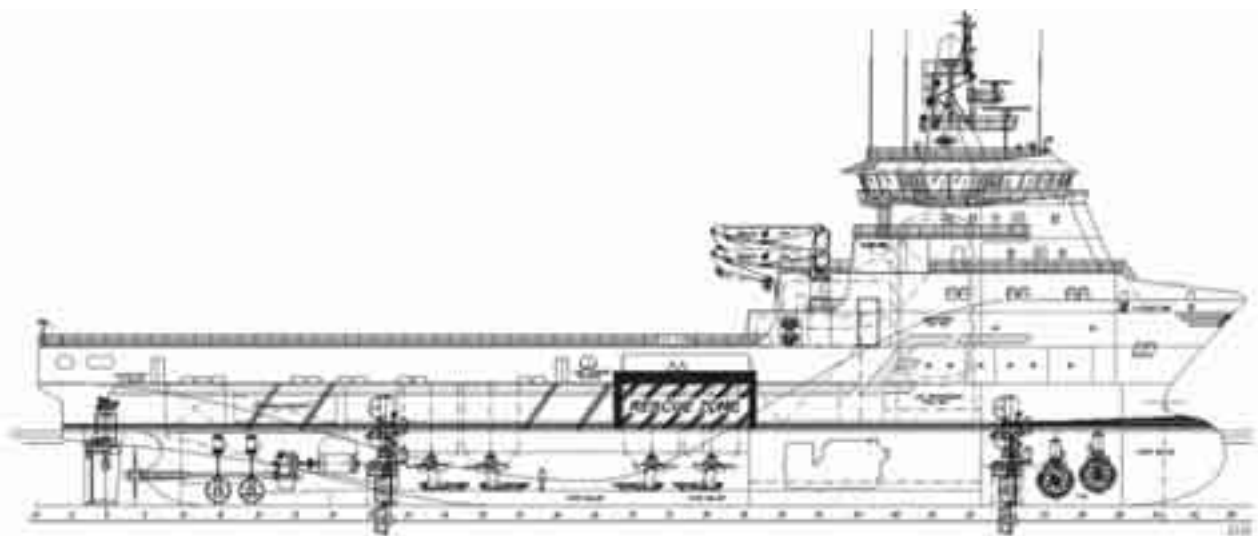

Fig. 6. Single propeller concept on a VS495PSV [2]

Tab. 2. Summary of propeller and thruster forces [2] for concept on Fig. 6

Propeller/thruster No.	Propeller/thruster name	Power [kW]	Maximum thrust [kN]
1	Main propeller	5100	700 (with nozzle 875)
2	Aft tunnel 1	830	102
3	Aft tunnel 2	830	102
4	Aft azimuth	880	150
5	Forward azimuth	880	150
6	Forward tunnel 1	880	108
7	Forward tunnel 2	880	108

In Tab. 3 is presented the calculated maximum DP capability with presented Wartsila LCC system taking into account the worst-case failure.

Tab. 3. Calculated maximum DP capability of Wartsila LCC concept of DP vessel [2]

System	Units in operation (*) means 50% power	Calculated maximum wind speed/significant wave height Hs capability	Comment
	All propeller/thrusters	37.6 kn/ Hs = 7.0 m	All thrusters including main propeller in operation
	All thrusters without propeller	37.2 kn/ Hs = 6.9 m	Main propeller not in operation
LCC conventional	1*, 2*, 3*, 4,5,6*,7* 1,4,5	27.9 kn/ Hs = 4.8 m 15.6 kn/ Hs = 2.6 m	Worst single failure/ loss one section of switchboard
LCC conventional	2*,3*,4,5,6*,7* 4,5	23.1 kn/ Hs = 3.9 m 8.0 kn/ Hs = 1.6 m	Worst single failure/ loss one section of switchboard

As shown on Tab. 3 with the conventional electric system the capability is about 12 knots less wind speed, i.e. only moderate to fresh breeze environmental conditions, with the Wartsila LCC system close to moderate gale.

The possibilities of improving the Wartsila LCC system are:

- more than 4 main engines (gensets), for example 6,
- the switchboard may be divided into more section, for example 6, the possibility of generators work parallel or independent,
- a possibility of connection between generator and switchboard to two independent sections (with the choose one of them).

5. DP supporting systems

For DP operation is important not only the arrangement of propulsion system and its complicity but DP supporting systems as well. The main three producers of fully integrated solutions are Kongsberg, Norr Systems [8] and Converteam [10]. The co-ordination of the dynamic positioning system with the propulsion drives, power system and vessel management system is simpler, ensuring better performance and safe, efficient operation. The benefits are for the shipyard and ship-owner. Dynamic positioning interfaces can be embedded into the switchgear and variable speed drive cubicles, significantly reducing cabling and the time required installing on site, the complete assembly being fully pre-tested at the factory stage. The trials on the ship needs less time, sometimes only needed a small re-configuration. An example of integrated solution of DP supporting systems is presented on Fig. 7.

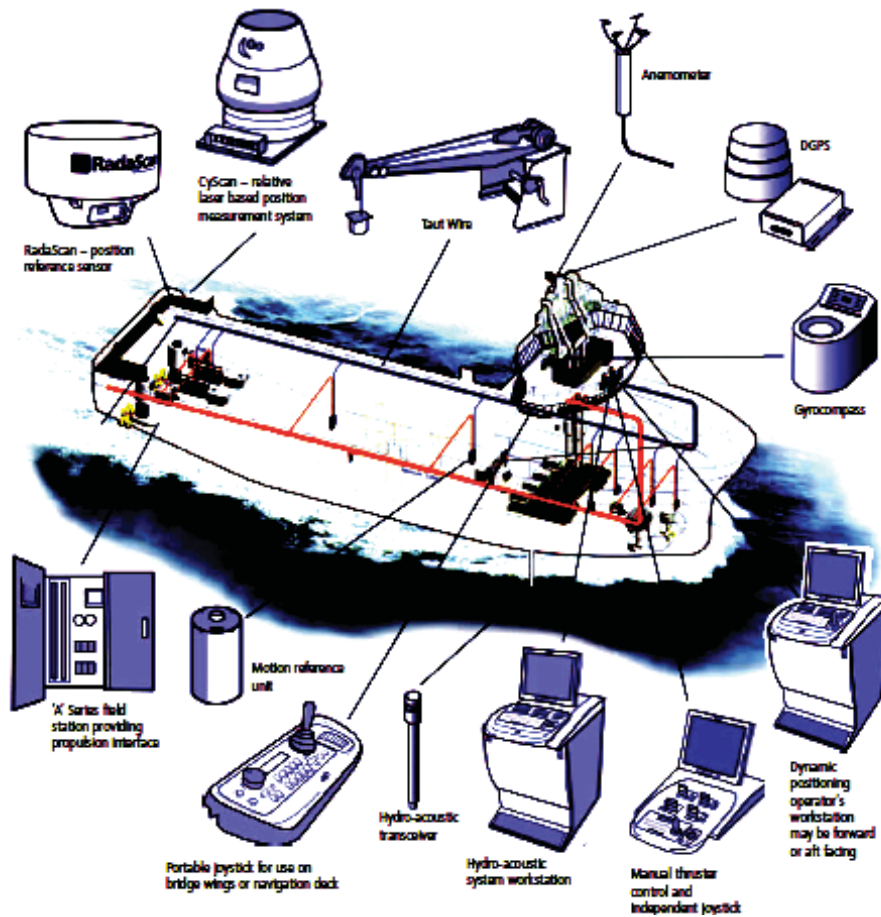

Fig. 7. Integrated solutions of DP supporting systems [10]

There are many elements for supporting like:

- manual thruster control and independent joysticks,
- portable joysticks for use on bridge wings or navigation deck,
- dynamic positioning operator's workstation (may be located forward or aft),
- gyrocompasses (minimum 3),
- motion reference units (minimum 2),
- "A" series field station providing propulsion interface,
- position reference sensors – RadaScan,
- relative laser based position measurement system,
- DGPS – differential GPS system,
- anemometers (minimum 3 for comparison),
- Taut Wire systems.

Depending of the DP class and type of vessel will be equipped in supporting systems according to classification society regulations and ship-owner request [1, 3, 9, 11].

There is possible some modes of operation during: manoeuvring, station keeping, tracking etc. For example during manoeuvring is possible [10]:

- Manual lever – using individual levers to control each of the thrusters,
- Joystick manual – combined control of all thrusters using a single joystick,
- Hand pilot – manual control using the joystick for ahead/astern thrust with a turning moment control for rudder or stern azimuth control. This mode also incorporates conventional manual steering,
- Joystick auto – combined thrust control using the joystick in manual for speed control with automatic heading control. Typically used during slow speed manoeuvring,

- Autopilot – ahead/astern thrust set by the operator via joystick or the operator may manually enter the vessel speed or propulsion speed into the system. Automatic heading control using stern propulsion and/or rudders to steer the vessel.

Presented CONVERTEAM's "A" Series dynamic positioning system is suitable for all types of vessels and applications. The system can be delivered with application-specific software to enable the customer to benefit from individually tailored solutions designed to meet their exact requirements.

6. Final remarks

In a practice, vessels equipped with DP system and DP supporting system, give a crew an enhanced comfort of work during operations because of their reliability and redundancy with required accuracy. Diesel-electric propulsion gives higher overall reliability and high flexibility due to arrangement possibilities like Wartsila LCC system, which is able to increase the DP capability. This way is improving the safety of DP operation.

One of the most important issues is to minimize fuel consumption for the actual operation profile and service speeds. Station keeping mode necessary for DP operation wastes a lot of energy, especially during bad weather condition. Using suitable solutions in the generating and delivering power, it is possible better utilization of propulsion system during DP operation.

References

- [1] *Guidelines for the Design and Operation of Dynamically Positioned Vessels*, IMCA M 103 Rev. 1, www.imca-int.com, December 2007.
- [2] Halstensen, S. O., Nordtun, T., *Improving Total Efficiency and Safety during DP-operations*, First International Symposium on Marine Propulsors, Trondheim, Norway, June 2009.
- [3] Herdzik, J., *Wymagania stawiane systemom dynamicznego pozycjonowania oraz możliwości ich weryfikacji*, Logistyka nr 5/2011, ISSN 1231-5478, pp. 635-640.
- [4] Sorfonn, I., *Power Management Control of Electrical Propulsion Systems*, Dynamic Positioning Conference, Wartsila N.A. Inc., October 2007.
- [5] *Design and Analysis of Stationkeeping Systems for Floating Structures*, American Petroleum Institute API, Third Edition, October 2005.
- [6] Mathewson, M. O., *Offshore Supply Vessel Positioning*, Dynamic Positioning Conference, Seatex Incorporated, October 1999.
- [7] Holvik, J., *Basics of Dynamic Positioning*, Dynamic Positioning Conference, Kongsberg Simrad Inc., October 1998.
- [8] *Norr P-Class Dynamic Positioning System & Electrical Propulsion*, Norr Systems, www.norrsystems.com
- [9] *Guidelines on Surveys of Dynamic Positioning Systems*, China Classification Society, Beijing 2002.
- [10] „A” series dynamic positioning. *The complete solution for manoeuvring and position control*. CONVERTEAM, Publication HH-ASDP-11/06.
- [11] *Rules for Classification and Construction Ship Technology*, chapter 15, Dynamic Positioning Systems, Germanischer Lloyd 2010.
- [12] <http://www.imca-int.com/divisions/marine/reference/intro05.html>.