

APPLICATION OF FINITE ELEMENT METHOD IN PRODUCTION OF COLLAR-HEAD SCREW IN SUSPENSION ARM OF MOTOR CAR VEHICLE

Andrzej Świątoniowski, Ryszard Gregorczyk

*AGH University of Science and Technology, Department of Manufacturing Systems
30 Mickiewicza Av., 30-059 Krakow, Poland
tel.: +48 12 6173107, +48 12 6173962
e-mail: swiatoni@imir.agh.edu.pl, gregorczi@imir.agh.edu.pl*

Stanisław Rabiasz

*Krosno State College, Mechanical Department
Rynek 1, 38-400 Krosno, Poland
tel.: +48 13 4375570*

Abstract

The subject of analysis is the process of hex cap screws forming designed to fix suspension arm bushing in a motor car. Due to specified requirements set on elements of that type have to meet, both in the scope of size and shape accuracy as well as mechanic properties of material, cold forging closed-die process is applied. Analysis of such process including the application of Finite Element Method in the form of software package DEFORM-3D was conducted. Results of the analysis may help to choose the number and sequence of technological operations, their parameters and the proper shape of tools.

The paper presents: suspension arm assembly, computer model presenting screw cold forging technology, work-hardening curve for AISI-1010 (ISO-C10) steel, boundary conditions of simulation, FEM model parameters in the subsequent phases of the process, analysis of accuracy of geometrical measures of screw obtained in simulations of particular phases of the process, discrete and actual model of obtained screw, the form of stained net of the hex cap screw with visible ZY central plane in its section, deformation distribution in screw head after second upsetting process, change in strain rate of the screw in time, filling of pass die, stress fields in screw determined in accordance with Huber's hypothesis, force of screw head upsetting in the function of the travel of the upper die.

Keywords: motor car suspension, cold forget process, collar-head screw

1. Introduction

Arms are rigid elements of suspension which due to articulated joint with stub axle or journal of road wheel hub on one side and integral body support or frame on the other side, enable independent space deflection of wheels in a vehicle. Separate group constitutes systems of single trailing arms sloping against longitudinal axis called semi-trailing arms. Elements of vehicle suspension i.e. arms and shock absorbers are subject to quickly-changing dynamic loads. Therefore, fatigue stress threatening life and safety of construction may appear. At the same time, long observations has made it possible to state that screws designed to fix suspension arm bushing are at the biggest risk (Fig. 1).

Taking into account special requirements these elements have to fulfil, both in the scope of mechanical properties of material, precision and corrosion resistance, fleshless, cold forging closed-die process is applied. Basic stock material used during this process is annealed wire rod manufactured today up to $\Phi = 30$ mm in diameter. In special cases, drawn bars are used as stock, which apart from higher surface quality are more size-accurate. Strain resulting from drawing has

positive influence on crystallographic texture, and at the same time, on its resisting parameters. Such technology is used if required resistance is to be obtained through cold working without heat treatment.

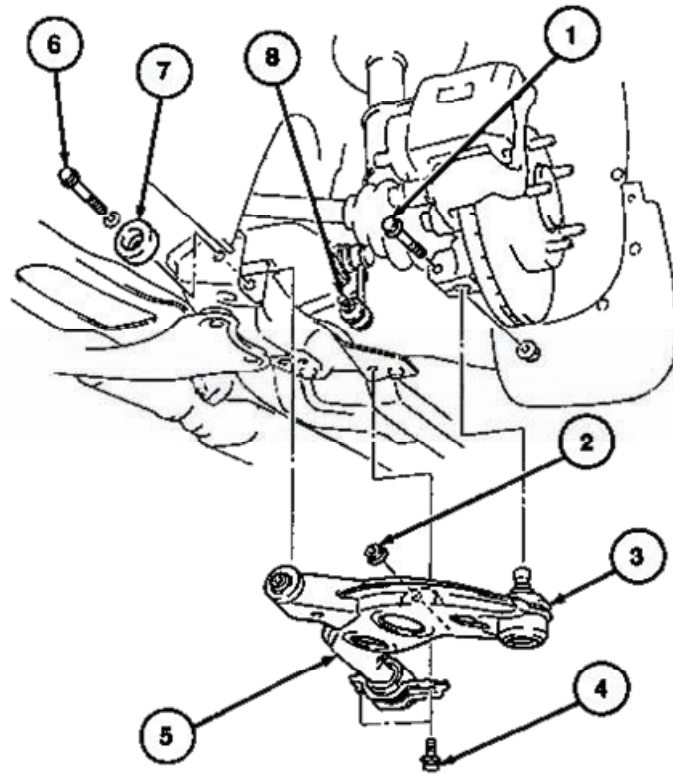

Fig. 1. Suspension arm assembly. 1 - Suspension arm pin blocking bolt, 2 -Stabilizer bar connecting rod nut, 3 -Suspension arm bolt, 4 - Rear suspension arm bush mounting bolt, 5 - Suspension arm, 6 - Front suspension arm bush mounting bolt, 7 - Rubber insulator, 8 - Stabilizer connecting rod

2. Computer simulation of screw forming process

The subject of simulation is the forming process of collar-head screw of M 5x30 suspension arm whose shape remains compatible to GB 5790-86 norm and applied technology is compatible to DIN ISO 8992 norm. Screws and nuts. General requirements. Process analysis was conducted drawing on Finite Elements Method in the form of a software package DEFORM-3D [7].

It was assumed that the material would undergo plastic strain in rigid non-deformable closed die impression. The subject of analysis is evaluation of the influence of tool's (die's) shape on the course of plastic flow and impression filling. These are factors determining the appropriateness of chosen technology as well as the quality of ready product. Impression's shapes were designed in Autodesk Inventor package. On the basis of previous experience in this field, it was assumed that the screw forming process would be divided into two phases:

- first phase - extrusion which involves two successive operations during which throat under screw head (Fig. 2. position 1) and throat for screw thread are formed. (Fig. 2, position 2)
- second phase - two-stage upsetting leading first to forging conic part of screw head and then its formation together with collar and hexagon so that it would fit the key.

In simulation calculations it was assumed that suspension arm screw would be forged in AISI-1010 (ISO-C10) steel in normalized state. Yield stress value of material amounts to $\sigma_p=380$ [MPa]. In the simulation the model of isotropic strengthening material, the same in all cases, was used Fig. 3.

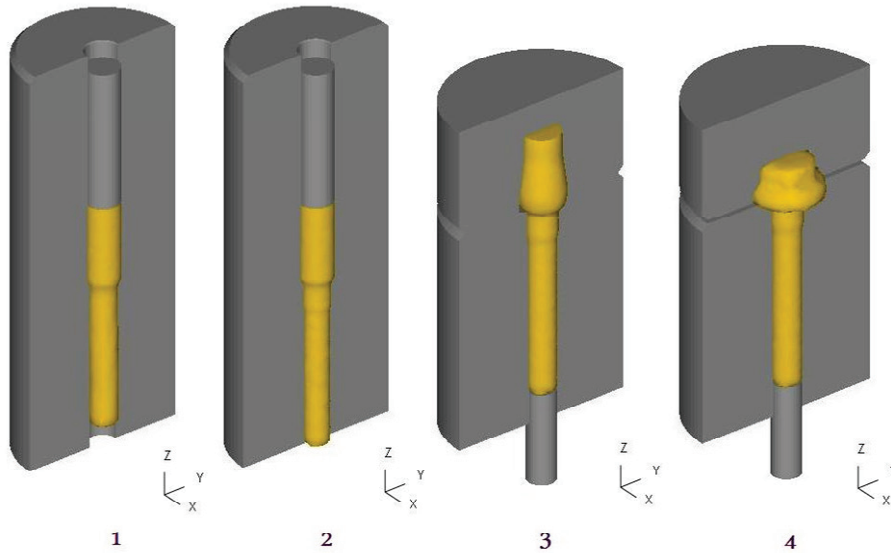

Fig. 2. Computer model presenting screw cold forging technology

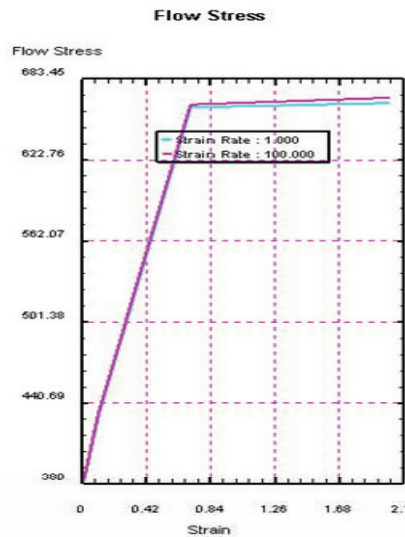

Fig. 3. Work-hardening curve for AISI-1010 (ISO-C10) steel

Complex technology of forging without flash requires the volume of stock material to be equal to the volume of die impression. Taking that into account, Autodesk Inventor package enabled us to assume stock size in the form of a bar with diameter $d_0 = 6.1$ mm and length: $l_0 = 31.8$ mm. These measurements were applicable for discrete stock model.

Boundary conditions are presented in Tab. 1.

Tab. 1. Boundary conditions of simulation

| Metal-tool friction factor | Stock temperature | Die temperature | Tool(punch) movement speed |
|----------------------------|-------------------|-----------------|----------------------------|
| μ | $T^{\circ}C$ | $T^{\circ}C$ | v mm/s |
| 0.12 | 20.0 | 150.0 | 250 |

Average tool (press ram) movement speed amounted to $v = 250$ mm/s. This speed rate, in the face of change of friction work to heat on the contact surface of die's and punch's walls, limits temperature drop and secures tools life. It is also compatible with values used in new presses [2].

However, it's worth noting that in simulation conditions deformation speed undergoes change in different points and stages of deformation.

DEFORM 3D package has a determined tetragonal form of finite elements net, which should undoubtedly be considered as its limitation. However, the number of elements appearing in particular simulations is unconstrained. It was decided that due to the necessity to limit calculation time to that accepted in industrial conditions of process design the number of these elements in first three initial forming operations would be limited to 9000. In order to obtain credible results, this value was increased in the last simulation (Tab. 2).

Tab. 2. FEM model parameters in the subsequent phases of the process

| Ordinal number | Operation | The form of FEM net | Number of elements | Number of nodes | Simulation time [min] |
|----------------|---|----------------------|--------------------|-----------------|-----------------------|
| 1 | Extrusion – shaping throat for screw head | Tetragonal four-node | 8240 | 1959 | 60 |
| 2 | Extrusion – shaping throat for screw thread | Tetragonal four-node | 8303 | 2057 | 90 |
| 3 | Upsetting screw head into cone | Tetragonal four-node | 8353 | 2064 | 120 |
| 4 | Final upsetting screw | Tetragonal four-node | 31389 | 7327 | 410 |

3. Results of the analysis

The analysis of hex cap screws (Fig. 4) was conducted in the scope of:

- geometrical compatibility of forged screw with its nominal measurements (norm requirements)
- level of die impression filling
- material flow, determining of zones and strain values
- speed of strain formation, change of that speed during the process
- actual stress
- force parameters

The fact that geometrical dimension deviations of a screw will remain smaller than those stated in tolerance range constitutes basic criterion for evaluation of simulation accuracy and its usability in the planning process.

Meeting that condition was the subject of analysis after completion of each operation (Tab. 3), especially because slug forgings obtained this way were used as stock for the successive operations.

Tab. 3. Analysis of accuracy of geometrical measures of screw obtained in simulations of particular phases of the process

| Actual dimensions | Model measurement | Absolute error | Relative error |
|-------------------|-------------------|----------------|----------------|
| 9.24 | 9 | 0.24 | 2.5% |
| 3.23 | 3.1 | 0.13 | 4.0% |
| 5.40 | 6.0 | 0.6 | 11.1% |
| 5.00 | 4.6 | 0.4 | 8% |
| φ5 | 4.9 | 0.1 | 2% |
| φ4.57 | 4.52 | 0.05 | 1.09% |
| φ11.80 | 11.3 | 0.5 | 4.23% |
| 8 | 8 | 0 | 0% |

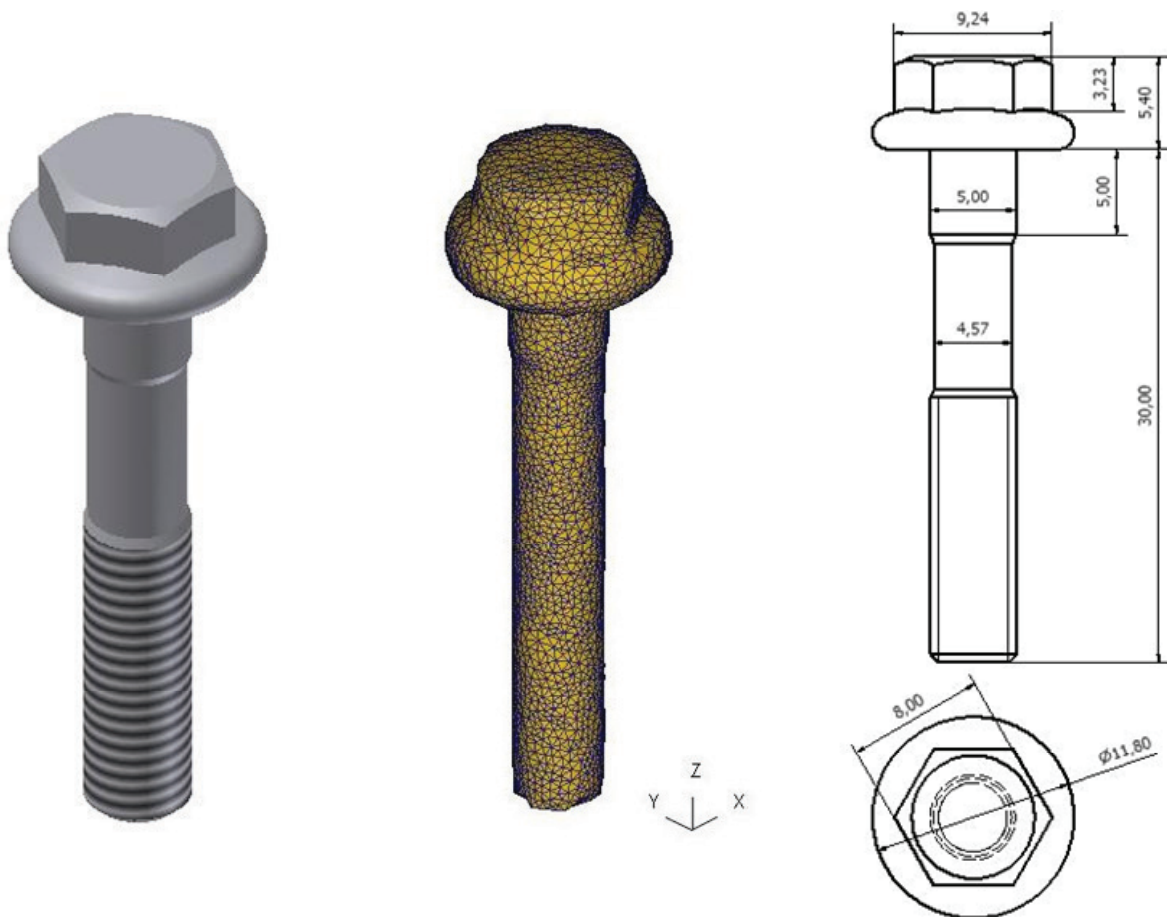

Fig. 4. Discrete and actual model of obtained screw

It has been found that the biggest (11.1%) discrepancies were observed in upsetting operation and concerned the height of screw head. Second error (8%) appeared in second extrusion operation and concerned the diameter of cylindrical part of screw (throat) under its head.

Reasons for such discrepancies may originate from inappropriate choice (at this stage of simulation) of forming die impressions. In other operations geometrical errors of the screw do not exceed 4%, which proves to be a positive result.

4. Deformation state of screw's material after the end of the process

The state of strain in forged screw after the end of second upsetting process was shown in Fig. 5. The Flownet tool, which made it possible to watch the deformation of material flow in vertical plane, was used.

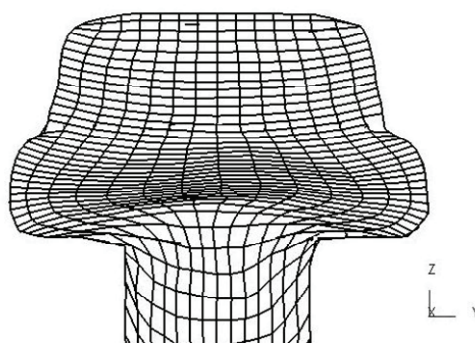

Fig. 5 The form of stained net of the hex cap screw with visible ZY central plane in its section

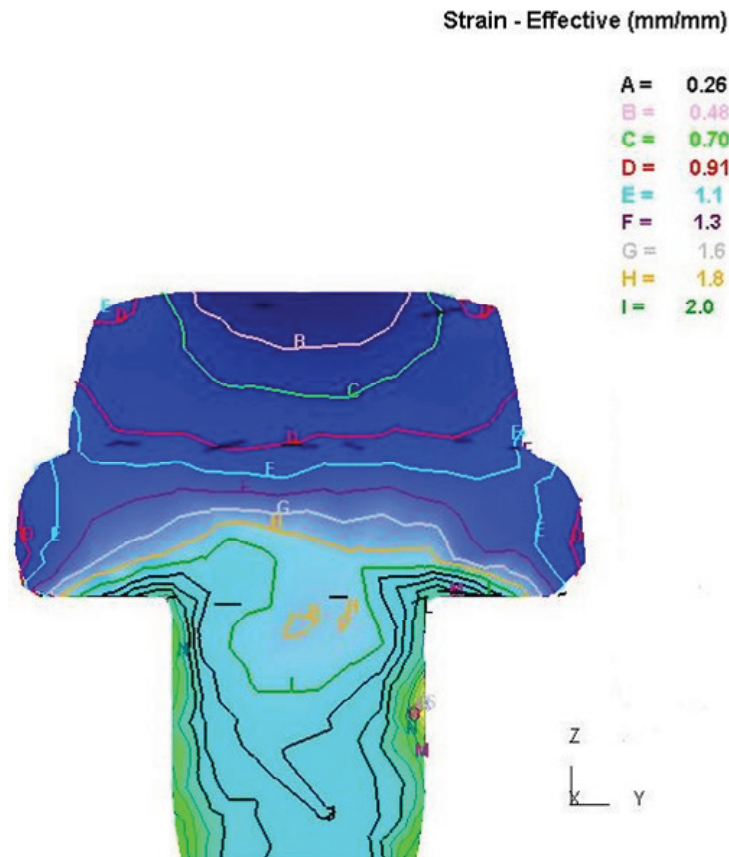

Fig. 6. Deformation distribution in screw head after second upsetting process

It's visible that in the area of screw head there is a non-uniform level of material deformation, which is synonymous to non-uniform strengthening. Deformation has its centre in the inner part of collar with its value amounting to $\phi_p=2$. This should be considered as a positive result if we take into account loads affecting the screw during its functioning as an element of a vehicle's suspension (Fig. 1).

Deformation value amounting to 0, 91 (point D) and presented in Fig. 6, may be perceived as a result of filling the narrowest gaps in upper die impression.

The analysis of change in strain rate in the last phase (upsetting of screw head) may also provide interesting information.

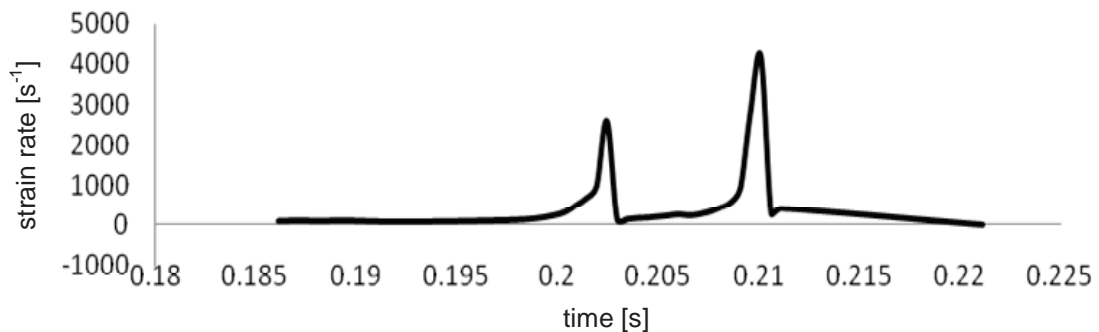

Fig. 7. Change in strain rate of the screw in time

Increase in strain rate amounting to $\epsilon' = 4.2 \cdot 10^3 \text{ s}^{-1}$, which is observable in 0.21 sec of screw head upsetting process, corresponds to the beginning of die filling in its collar part and forming that very part of screw. Material flow radiates the whole collar circuit, which is why the strain rate is so high.

5. Filling of die impression

One of basic factors ensuring proper formation of a screw is appropriate material distribution in the whole pass die so that the material first fills the part for key and the collar formation may come next. Such course of deformation process results in huge material strengthening in the inner part of collar, which was confirmed by previously shown analysis outcomes.

That condition was also met in the simulation. It turned out to be impossible to ensure the full die filling on the whole impression circuit. It is presented in Fig. 8; lack of filling, which amounts to 79% and results in limitation of material-tool contact surface, is especially vivid in the upper part of die shaping sharp edges of screw head. Such state of matters should undergo correction in further simulations.

Figure 8 shows that top tool, especially sharp edges of screw head, was the least-filled part of die. There the upper die-received product contact was limited, which may be seen in Fig. 8. Die impression filling in the last forging operation amounted to 54%, which indicates serious inadequacy in that operation.



Fig. 8. Filling of pass die

6. State of stress in the forged screw

Stress values in screw material in the last phase of their formation which were determined on the basis of Huber's hypothesis, are presented in Fig. 9.

The highest stress values 670 [MPa] were observed in the collar part of screw and the cylindrical part of screw under its head into the screw-thread part. Relatively lower stress values amounting to 560 [MPa] are to be found in the core of screw head.

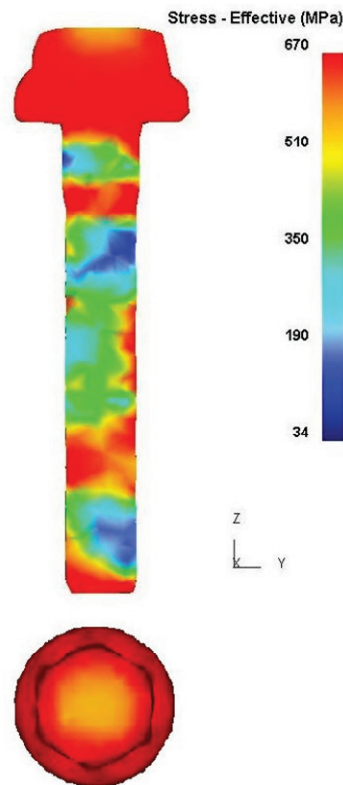

Fig. 9. Stress fields in screw determined in accordance with Huber's hypothesis

7. Force of screw head upsetting

DEFORM 3D software package used in the simulation enables the analysis of force parameters of the process in question. Fig. 10 shows the course of pressure force of a punch during the final upsetting operation. In accordance with the process mechanics maximal upsetting force, which is about 70 kN at the rising of the upper die 7mm, was registered at the end of impression filling.

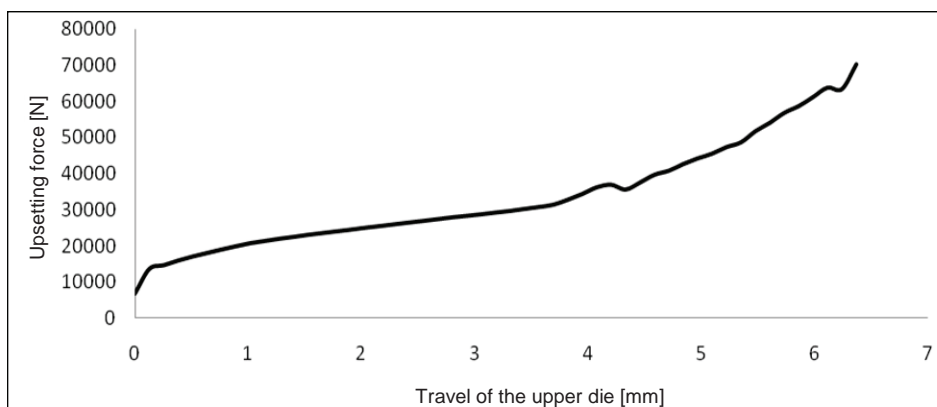

Fig. 10. Force of screw head upsetting in the function of the travel of the upper die

8. Conclusions

This research confirmed that technology used to form screws found in vehicle's suspension arms involving closed die forging was appropriate.

The basic results of computer simulation of suspension arm forming process were set up in Tab. 4.

Tab. 4. Analysis results of the process of slug forming in subsequent cold forging operations

| | Deformation ε | Deformation – maximal strain rate ε' [s^{-1}] | Actual stress σ [MPa] | Extrusion force P_w [kN] |
|--------------------------------|------------------------------|---|---------------------------------|-------------------------------|
| Operation 1- coextrusion | 0.85 | $1.8 * 10^3$ | 675 | 23.3 |
| Operation 2- coextrusion | 2 | $20 * 10^3$ | 680 | 40.2 |
| | Deformation ε | Deformation – maximal strain rate ε' [s^{-1}] | Actual stress σ [MPa] | Upsetting force F_s [kN] |
| Operation 3 -slug upsetting | 0.32 | $30.1 * 10^3$ | 680 | 27.6 |
| Operation 4 -slug upsetting | 2 | $4.2 * 10^3$ | 670 | 70 |

The simulation provided opportunity to determine proper shape of tools as well as parameters which enabled forging of die collar screw whose measurements fitted required tolerance intervals and the level of strengthening which ensures high resistance properties was obtained.

References

- [1] Wasiunyk, P., *Kucie Matrycowe*, Wydawnictwo Naukowo-Techniczne, Warszawa 1975.
- [2] Sińczak, J., *Procesy przeróbki plastycznej*. Wydawnictwo Naukowe AKAPIT, pp. 194-218, Kraków 2001.
- [3] Heinz, J., Tschachtsch, A., *Metal forming practise*. Berlin Heidelberg : Springer - Verlag, pp. 18-32, 2006.
- [4] *Presse und Informationen*, <http://www.schrauben-gross.de>.
- [5] Sińczak, J., Skubisz, P., Kula A., *Zastosowanie metod numerycznych do analizy kucia śrub na zimno*, Hutnik , Wiadomości Hutnicze, T. 70, 10, pp. 434 – 438, 2003.
- [6] Sińczak, J., Skubisz, P., *Konstrukcja matryc składanych do kucia bezwypływkowego na prasach śrubowych*, Mechanik, 10, 2008.
- [7] Sińczak, J., Skubisz, P., *Konstrukcja matryc składanych do kucia bezwypływkowego na prasach śrubowych*. Mechanik, 10, 2008.
- [8] DEFORM-3D Manual
- [9] Sińczak, J., Jakubowski, Ł., Skubisz, P., *Technologia jednooperacyjnego kucia precyzyjnego elementów cienkościennych*, 17 International Scientific And Technical Conference Design and Technology of Drawpieces and Die Stamping, Poznań- Wąsowo 2008.