

CONTROL PROBLEMS IN A TURBOCHARGED SPARK-IGNITION ENGINE

Władysław Mitianiec, Łukasz Rodak

Cracow University of Technology
Jana Pawła II Av. 37, 31-864 Krakow, Poland
tel.: +48 12 6283692, +48 12 6283687, fax: +48 12 6283690
e-mail: wmitanie@usk.pk.edu.pl, lrodak@pk.edu.pl

Abstract

The paper presents the problems of adapting of the charge system to the standard four stroke spark ignition engine Toyota Yaris 1300 cm³ with compression ratio 10.5. The main problem in charged spark ignition engine is control of air-fuel ratio near stoichiometric values at different boost pressure in order to obtain higher torque at the same level of specific fuel consumption and exhaust gas emission. Charging of such engine is connected with the problem of knock in the medium and high values of load at low engine speeds. Higher boost pressure leads to abnormal combustion process and to knocking. The paper describes the boost pressure control algorithm which enables to prevent the knock, so the engine can work near the knock boundary. The article includes a description of the engine, the method of charging and test bench, which was built to verify the proposed control algorithm for boost pressure. The publication contains the results of different tests conducted on the supercharged engine stand by the proposed algorithm and measured parameters were torque, fuel consumption and volumetric concentration of the main exhaust gas components. Applying of turbocharger in SI engines leads to knocking. The controlling of combustion process in SI engine is realized on the adjustment of WG or VTG to decrease or increase the rotational speed of turbocharger. Such control causes the engine work near boundary of knocking.

Keywords: transport, combustion engine, turbocharging

1. Introduction

Exhaust-gas turbochargers for passenger cars generally use single flow turbine housings. Presently standard practice favours regulating flow on the exhaust side, whereby a portion of the engine's exhaust gases is routed past the turbine (bypass) using the governing mechanism (waste-gate), which can be in the form of a valve, or flap or using variable turbine geometry (VTG). Till now generally the waste-gate (WG) or VTG is controlled by a pneumatic mechanism. In order to control of the air flow rate to the inlet system, particularly in SI engines, the system should have a pressure sensor or air flow rate sensor to give a signal to the waste-gate. The necessary control pressure in the upstream side of the turbine in order to regulate the mass flow rate of the exhaust gas should be assured by a control system. Sometimes it is possible to combine turbocharger and waste-gate in a single unit. Recently the control of the flow rate of exhaust gases through the turbine is assured by the PID controller. The most important factor is controlling of air-fuel ratio in SI engines in narrow range about 15.0. Cooperation of fuel system and turbocharger unit is depended on PID controller in order to control dose of injected fuel in relation to air mass flow rate and avoiding a knock combustion process in all cylinders. High pressure in the inlet pipe behind the compressor causes higher initial pressure during induction stroke and at the same compression ratio as in standard engine and higher fuel dose it increases maximum cylinder pressure during combustion process. Applying of turbocharger in SI engines leads to knocking. The controlling of combustion process in SI engine is realized on the adjustment of WG or VTG (control of mass flow rate through the turbine) to decrease or increase the rotational speed of turbocharger and thus the change of air mass flow rate and inlet pressure. Such control causes the engine work near boundary of knocking. Very important is the proper choice of PID parameter,

particularly integral and proportional coefficients, which should change in time. The work of the turbocharging SI engines was analyzed by numbered of scientist in the world [1] and turbocharging systems are described also by polish scientists (Wislocki [9]). Control of the work of turbocharger in SI engines is considered for example by Colin et al [4] and Arbogast et al [2].

2. Mathematical model of the turbocharger

The turbine shaft power can be determine from the isentropic expansion of the gas in the blades from the following formula [7]:

$$N_t = m_{ex} \cdot \eta_{t0} \cdot \frac{k_{ex}}{k_{ex} - 1} \cdot R_{ex} \cdot T_{ex} \cdot \left(1 - \left(\frac{p_{t2}}{p_{t1}} \right)^{\frac{k_{ex}-1}{k_{ex}}} \right), \quad (1)$$

where:

m_{ex} - mass flow rate of the exhaust gases through the turbine,

η_{t0} - turbine efficiency,

k_{ex} - ratio of specific heats in upstream of turbine,

T_{ex} - temperature of the exhaust gases,

p_{t2} - downstream turbine pressure,

p_{t1} - upstream turbine pressure,

R_{ex} - temperature of the exhaust gases.

Power consumed by the compressor has the similar form:

$$N_{cmp} = m_{cmp} \cdot \eta_{cmp0} \cdot \frac{k_{cmp}}{k_{cmp} - 1} \cdot R_{cmp} \cdot T_0 \cdot \left(\left(\frac{p_{c2}}{p_{c1}} \right)^{\frac{k_{cmp}-1}{k_{cmp}}} - 1 \right), \quad (2)$$

where index *cmp* is referenced to the compressed air and *c2* and *c1* are the index of the air after and before the compressor. Temperature T_0 is referenced to the ambient conditions. Efficiency η_{cmp0} is defined at reference conditions ($p_0 = 1$ bar and $T_0 = 293$ K).

Instability of the turbocharger work is caused by power difference of the compressor and turbine and change of angular velocity of the turbocharger shaft is determined from the following formula:

$$\Delta\omega = \frac{\Delta t(M_t - M_{cmp} - M_{fr})}{J}, \quad (7)$$

where:

M - torque,

J - shaft moment of inertia,

Δt - time step

M_{fr} - friction torque

In a steady state the power of the turbine and compressor are equal. For SI engine the mass flow rate of the compressor should assure the given relative air-fuel ratio λ . After comparison of the powers and taking into account the formula is obtained:

$$m_{ex} = m_{cmp} \frac{1 + \lambda L_a}{\lambda L_a}, \quad (3)$$

where L_a is the theoretical demand of the air to burn 1 kg of fuel. The pressure before the turbine is calculated from the following equation:

$$p_{t1} = \frac{p_{t2}}{\left\{ 1 - \frac{C}{\tau} \left[\left(\frac{p_{c2}}{p_{c1}} \right)^{\frac{k_{cmp}-1}{k_{cmp}}} - 1 \right] \right\}^{\frac{k_{ex}}{k_{ex}-1}}}, \quad (4)$$

where constant C and τ are calculated from the dependences:

$$\tau = \eta_{t0} \eta_{cmp0} \frac{T_{ex}}{T_0}, \quad (5)$$

$$C = \frac{\lambda L_a}{1 + \lambda L_a} \frac{k_{cmp}}{k_{cmp} - 1} \frac{k_{ex} - 1}{k_{ex}}. \quad (6)$$

An increase of the charge pressure requires also a certain increase of the pressure and temperature of the exhaust gases before the turbine blades. This can also be done by an increase of the total efficiency of both machines.

At assumption of the compressor efficiency 0.7, turbine efficiency 0.65 and downstream turbine pressure, which is almost equal the ambient pressure, the calculation were carried out in order to obtain required upstream turbine pressure as a function of different compressor pressure ratios. One assumes temperature of exhaust gases equal 1000 K. Variation of the required upstream turbine pressure is shown in Fig.1 for different air excess coefficients. Leaner mixtures require higher pressure before the turbine.

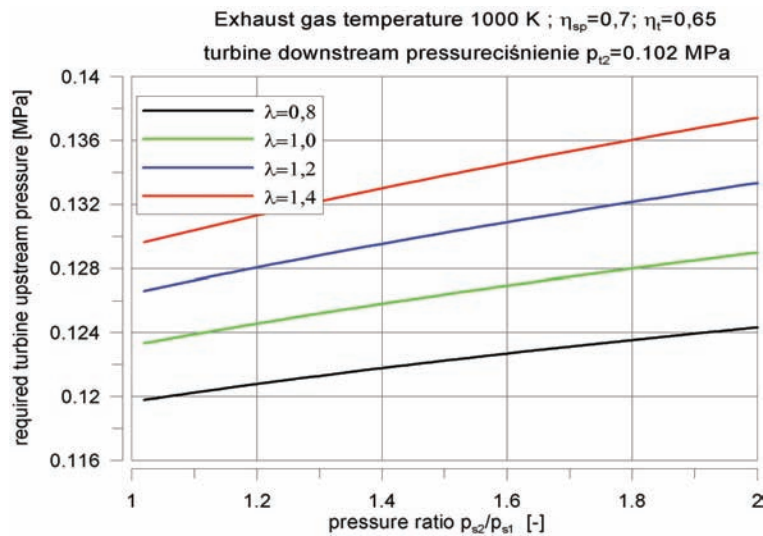

Fig. 1. Variation of turbine upstream pressure in a function of compressor pressure ratio for different air excess ratios

For the same air excess coefficient λ and assumed compressor and turbine efficiencies a required upstream turbine pressure depends also on upstream temperature of exhaust gases. Lower inlet temperature of exhaust gases in the turbine requires higher inlet pressure, because of lower decrement of enthalpy in the turbine at the same inlet pressure. Dependence of required inlet pressure of the turbine from compression ratio in the compressor for different inlet turbine temperatures is shown in Fig. 2. Higher temperature of exhaust gases reduces required upstream pressure in the turbine for assumed compression ratio in the compressor.

The control of turbocharger in SI engines requires a special PID (proportional-integral-differential controller) unit, which enable change of mass flow rate through the turbine by using a waste gate unit or control kinetic energy of exhaust gases by using turbine variable geometry (VGT). A simple controlling of the turbocharger with PID controller is shown in Fig. 3 for adjustment of exhaust gas flow through WG or VGT.

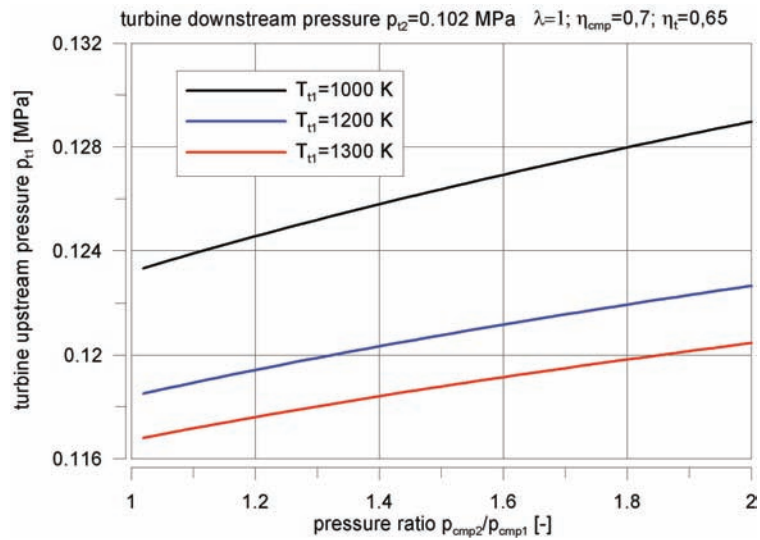

Fig. 2. Turbine upstream pressure as a function of compressor pressure ratio for three temperatures of exhaust gases before turbine

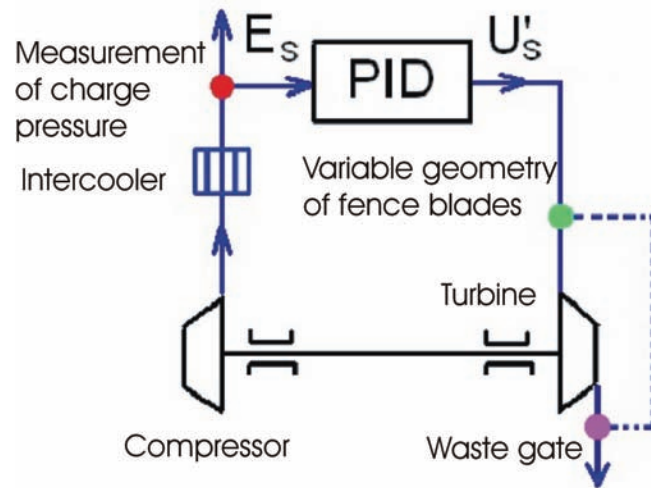

Fig. 3. Controller PID in turbocharging system

3. Control of mass flow rate in turbocharger

Amount of the delivered air from the compressor to the engine can be controlled in different ways: by waste-gate in the exhaust system, waste gate behind the compressor and by changeable nozzles flow in the turbine (changeable turbine geometry). In our case only the waste-gate in the exhaust system is considered. For this case the change of the pressure before the turbine is caused by the variable mass flow rate through the turbine. The valve in the waste-gate has to control the amount of the exhaust gases in the by-pass duct. The pneumatic device in the waste-gate system acts on the principle of the pressure difference (4) and does not take into account the required air-fuel ratio, turbocharger efficiency and thermal conditions influencing on the ratios of the specific heats (5)(6). The work of the gasoline SI engines requires keeping $\lambda \approx 1$ in strictly narrow tolerance and such the pneumatic control of the waste-gate is not a suitable solution. Therefore the SI engine with turbocharger requires electronically control system taking into account the following measured parameters: pressures and mass flow rates in the inlet and exhaust systems and required λ (throttle position). Air mass flow rate and measured value of excess air coefficient by λ -sensor give a signal for deliver a proper fuel dose by the injector. The system is based on the PID controller (proportional-integral-differential). In nearest future the SI low-turbocharged engines

should be equipped with PID controller in waste-gate exhaust system and variable turbine geometry for using of the turbocharger in whole engine operational loads and rotational speeds. Working with higher inlet pressure influences on the abnormal combustion process revealing with knock combustion. For that case by using the knock sensor it is possible to control the engine operation near boundary of knock region. In Cracow University of Technology special control system of turbocharged SI engines was developed and diagram of this system is shown in Fig. 4.

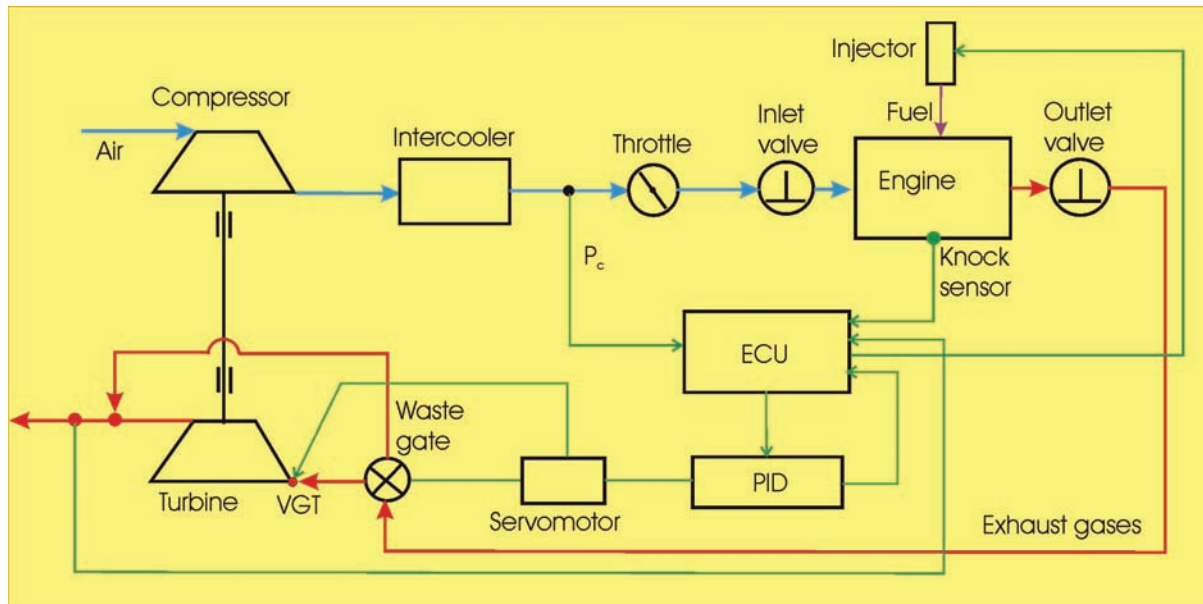

Fig. 4. The turbocharger and CNG direct injection control system

There are two ways of the parameter control in the prototyping: based on the thermodynamic model (mathematical dependences) and the other based on the control maps: fuel dose, mass flow rate, air-fuel ratio etc. in dependence of the rotational speed and throttle opening. Besides those the system has the throttle, intercooler, charger, turbine and waste-gate unit and variable geometry turbine. The control of the waste-gate and VGT occurs by use of PID controller by giving corrected parameters before the waste-gate model.

4. Experimental tests of SI turbocharged engine

Medium capacity engine Toyota Yaris 1300 cc SI engine for experimental test was equipped with VGT turbocharger with possibility to control mass flow rate in the turbine by using additionally WG system. Such approach enabled charging of the engine in wide range of rotational speeds and loads. Special computer control program in Labview environment was written in order to analyze knock signal and regulate the opening of VGT and WG in dependence on throttle opening (engine load). High voltage of knock signal was given to the electronic control unit (ECU), where was transformed by fast Fourier transform (FFT) procedure, which gave a distribution of knock signal in the range 2000-8000 Hz. Control signal from “knock” was obtained in the range 0 – 0.01 V and was transferred to the control unit for regulation of mass flow rate of exhaust gases through the turbine by VGT and WG. When output signal from FFT was grater than 0.01 V then the valve in WG was opened much more in order to reduce mass flow rate of exhaust gases through the turbine, which decreased rotational speed of the turbocharger and thus decreased pressure ratio behind the compressor.

When output signal had lower value than 0.01 V then VGT and WG enabled higher mass flow rate through the turbine and increase of pressure ratio in the compressor. Air mass flow rate measured by sensor upstream the compressor and measurement of excess air coefficient by

λ -sensor in the outflow system were the inputs for control of fuel dose of injectors. The engine was operated at constant rotational speed and upper limit of absolute outlet pressure in the compressor was determined on the level 1.3 bar.

The real signal from the knock sensor located in the cylinder block without filtration is shown in Fig. 5 in time function registered for $n=2150$ rpm and for upper limit of compression ratio in the compressor equal 1.3. Knock boundary was found as 1V and is shown in figure by dashed lines. In a short time 0.2 s several abnormal combustion processes are taken place in the cylinder. These signals include also signals from other sources. However one observes two knock signals during this short period.

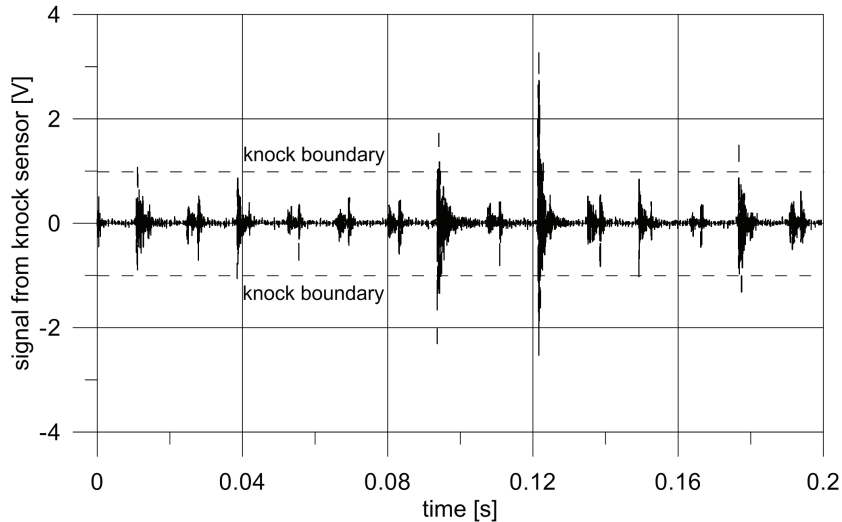

Fig. 5. Real signal from knock sensor

Filtration of the input signals from knock sensor takes place in the module FFT (Fast Fourier Transform), where all additional interferences are eliminated and only real signals from abnormal combustion process are taken into account. During experimental test it was found that knock signal takes place for frequencies 2000-8000 Hz with amplitude above 0.01 V. Such signal above 0.01 V is an input for decreasing of mass flow rate of exhaust gases through the turbine. The filtered signal from knock sensor is shown in Fig. 6, where two frequencies 3500 and 6000 Hz give an image of knock combustion in the cylinders.

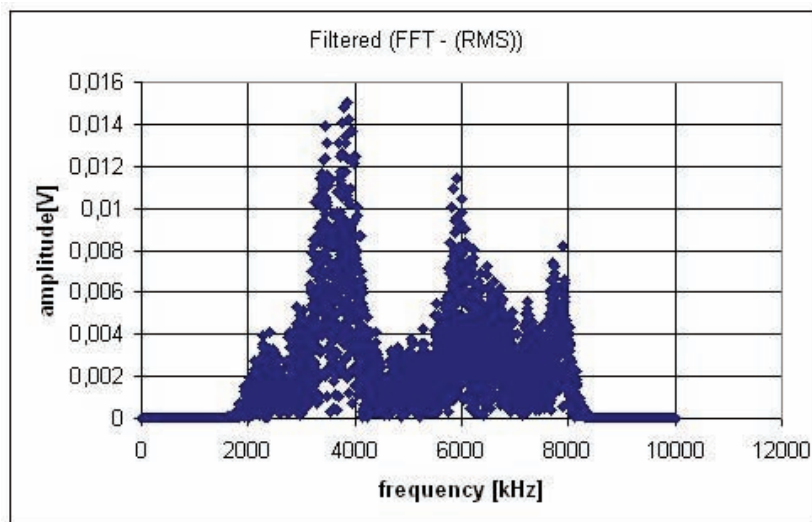

Fig. 6. Filtered signal (Fast Fourier Transform) from knock sensor

The outputs from knock sensors after filtration by FFT are the inputs for controlling of opening both VGT and WG in the turbocharger system. VGT system enables only changing of kinetic energy on the turbine inlet with the same mass flow rate by changing of absolute velocity of exhaust gases on the turbine' blades. On the other side the WG system changes mass flow rate \dot{m} through the turbine and thus the total turbine work depends on \dot{m} with the same specific non-isentropic work. By decreasing of WG opening ratio the total work of turbine also decreases and work done by the compressor is lower than for less opening ratio of WG. The change of waste gate opening ratio of the tested turbocharger during 670 seconds for rotational speed 2150 rpm is shown in Fig. 7, where one observes variation of this parameter from 0.3 to 0.8. Opening of the valve in the WG system was registered by a special inductance sensor connected with the level of the WG valve.

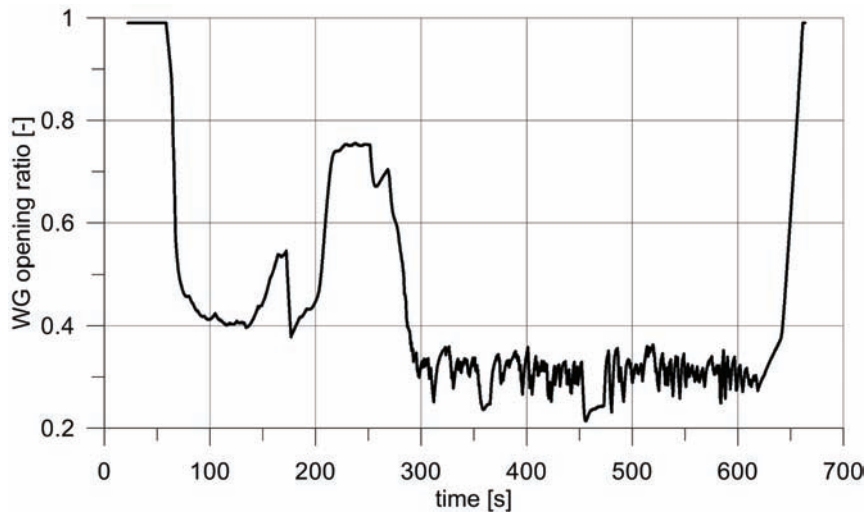

Fig. 7. Variation of change of waste gate opening ratio due to the PID signal

The signal of compressor outlet pressure was continuously registered by the control system in order to not admit an increase this pressure above 1.3 bar by the piezoresistive sensor before the throttle. The change of the signals of outlet pressure behind the intercooler for registered period 670 seconds is shown in Fig. 8, where one observes rapid changes of the pressure from 1 to 1.2 bar in a several seconds. Sometimes the signal of outlet compressor pressure reaches upper limit 1.3 bar. This signal is an input for change of opening both WG and VGT.

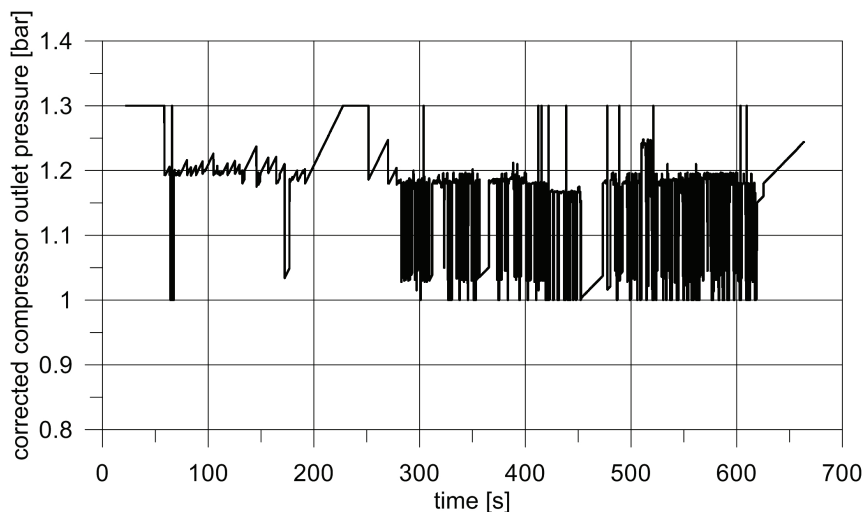

Fig. 8. Correction signal of outlet pressure in compressor in PID controller

The measured change of compressor outlet pressure is shown in Fig.9 for the same period 670 seconds. When one compares Fig. 8 and Fig. 9 it can be found relationship between correction signal and real values of pressure behind the compressor. The change of outlet pressure during period from 300 – 670 s is between 1.1 to 1.2 bar. Correction signal influences very quickly on the real outlet pressure in the compressor.

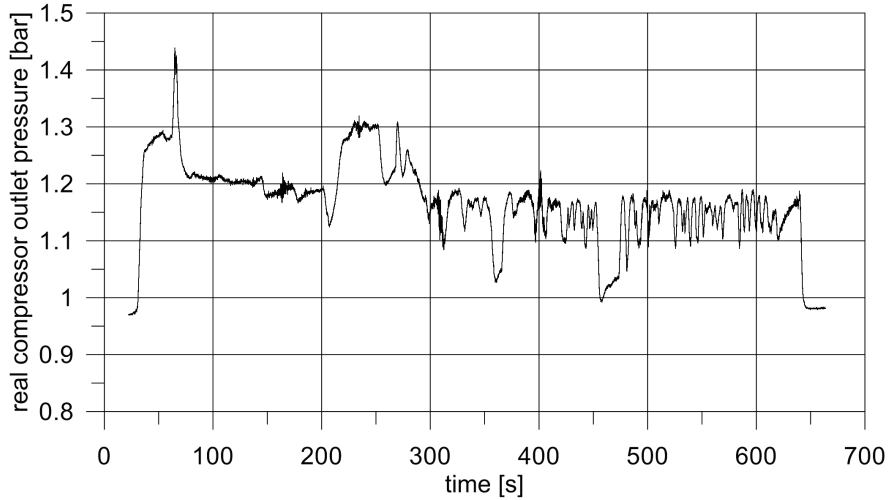

Fig. 9. Variation of real outlet pressure from compressor

Higher pressure in the inlet system causes higher volumetric efficiency of the engine and in order to assure the same air-fuel ratio near stoichiometric value the fuel dose was increased, which caused higher fuel consumption. Higher fuel dose per one cycle caused higher cylinder pressure and a significant increase of engine torque. Change of torque and input signals for control of VGT and WG systems depends on throttle opening. Fig. 10 presents variation of engine torque and throttle opening during period of 670 seconds at rotational speed 2150 rpm.

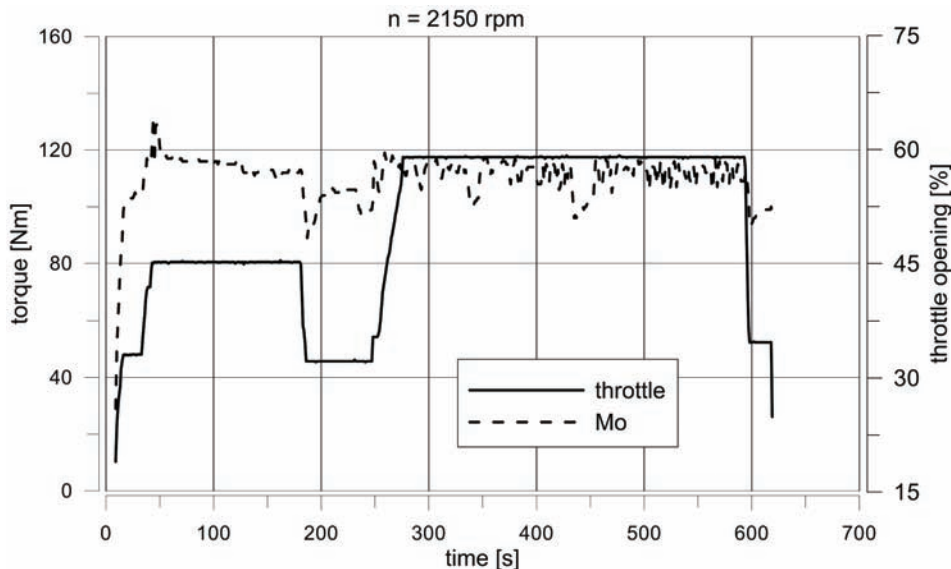

Fig. 10. Change of engine torque and throttle opening

An increase of throttle opening does not assure higher engine torque because of limitation of upper compressor outlet pressure. For this engine one obtained increase of torque at $n=2150$ rpm from 90 Nm for natural aspirated engine to 120 Nm for turbocharged engines with combustion process near boundary of knocking.

5. Conclusions and remarks

The paper concerns a controlling of the turbocharger work in SI engines. These considerations are mostly based on simulation and experimental work carried out on Toyota Yaris 1300 cc engine on dynamometer stand. The paper includes mathematical model of the work conditions of the turbocharger and measurement control signals on the turbocharged engine. On the analysis the following remarks can be presented:

1. Turbochargers in SI engines have higher thermal loads and required better control system because of the deliver strictly defined air-fuel ratio at different loads and rotational speed.
2. The modern turbocharged SI engines will be equipped with PID controller both for WG and VGT cases.
3. The operation of the PID controller occurs with connection of the pressure and temperature sensors in the boost and turbine ducts. Correction of input signal in the turbine changes as a result of the signal received from boost pressure sensor.
4. In an unsteady operation time of regulation depends on the correction factors given in the PID (boost controller) and in the carried out simulations the time amounted 2 s.
5. The turbocharging engine with VGT and WG systems gives about 30% higher brake torque in comparison to normal aspirated engine without knock combustion process.

Applying of the electronically controlled system with PID controller enables better regulation of the flow both exhaust gases through the turbine and air flow from the compressor

References

- [1] Andersson, P., *Intake air dynamics on a turbocharged SI-engine with wastegate*, Ph.D. thesis, Linköping University, Sweden 2002.
- [2] Arbogast, J., Cooper, D., Rice, R., *Model-Based Tuning Methods for PID Controllers*, Control Station Inc., Tolland USA 2004.
- [3] *Automotive Handbook*, Robert Bosch GmbH, Stuttgart 1996.
- [4] Colin, G., Chamaillard, Y., Bloch, G., Corde, G., *Neural control of fast nonlinear systems—application to a turbocharged SI engine with VCT*, *IEEE Transactions on Neural Networks*, 18 (4), pp. 1101–1114, 2007.
- [5] *GT-POWER Tutorials, version 6.2*, Gamma Technologies, Westmont, USA 2006.
- [6] Heywood, J. B., *Internal Combustion Engine Fundamentals*, Mc Graw-Hill, 1988.
- [7] Mitianiec, W., Jaroszewski, A., *Modele matematyczne procesów fizycznych w silnikach spalinowych małej mocy*, Ossolineum, Wrocław-Warszawa-Krakow 1993.
- [8] Wajand, J. A., Wajand, J. T., *Tłokowe silniki spalinowe średnio- i szybkoobrotowe*, WNT, Warszawa 1997.
- [9] Wisłocki, K., *Systemy doładowania szybkoobrotowych silników spalinowych*, WKiŁ, Warszawa 1998.