

ANALYSIS OF STRESS-STRAIN STATE OF PLATES UNDER IMPACT LOADING

Vyacheslav V. Astanin, Mykola M. Borodachov, Svitlana Yu. Bogdan

National Aviation University, Department of Mechanics
Komarova Ave. 1, 03680 Kyiv, Ukraine
tel.: +38 444975148, fax: +44 4973141
e-mail: astanin@nau.edu.ua

Abstract

The problem concerning the stress-strain state of a plate under impact load with various intensity levels of collision momentum applying finite-element method was considered. The problem concerning transversal impact of a body in form of a mass point or a finite body to the sheet-formed structures of following type: a plate, a plate strengthened by ribs, a plate with damages was considered.

Problem design diagram, design diagram of plate, fields of deflection intensities distribution w for plate central surface, stress distribution fields of the plate based layer, stress distribution fields of the plate based layer equivalent stresses σ_{eq} , relations for $\sigma_{eq} = f(m)$ and $w = f(m)$ at variation of impact initial velocity, impulse form of view, deflection and equivalent stress σ_{eq} intensity distribution diagrams in cross-section kn depending on view form of impulse, the diagram of plate's deflections, the stress field σ_{eq} of the plate caused by impact body of finite dimensions, the field of deflection intensity distributions w for damage plate, the field of equivalent stress intensity distributions σ_{eq} for damage plate, the structure diagram of plate with stringers, the deflection field of plate with stringers, diagrams of equivalent stresses σ_{eq} of plate with stringers in central cross-section along axis x at damage deeps are presented in the paper.

Keywords: impact loads, dynamic loads, plate, strengthened ribs, plate with damages, numerical methods, stress-strain state

1. Introduction

The problem concerning transversal impact of a body in form of a mass point or a finite body of different form to the sheet-formed structures of following type: a plate, a plate strengthened by strips or ribs, a plate with damages was considered.

The stress-strain state of above-mentioned structures is defined by elastic approach under different level of impact impulse applying finite element method (FEM).

The issues related to impact loading are important during operation of plains, vehicles and military equipment as well. The impact phenomena should be taken into account when determining of structures dimensions and their cross-sections in order to prevent from their untimely failure.

The stress-strain state of a plate, rigid fixed along its perimeter, under impact was studying. For that plate, it is impossible to obtain strong analytical solution, especially if the problem is complicated by presence of the ribs, damages, strips etc. Therefore, for calculation the approximate analytical and numerical methods were applied.

For solution of denoted problem, the finite element method (FEM) in form of displacement was used. This method was realized in software complex LIRA-9.4. The software is assigned for analysis, studying and design of structures in engineering industry, bridge construction, civil engineering, nuclear power engineering, oil industry and structures for others industrial fields.

The represented calculation approach is based on a combination of numerical methods and basic principles of impact theory under expansion by oscillation modes.

2. Statement of problem

It was analyzed a thin rectangular plate the central surface of which is located on plane xOy and axis z is directed down (Fig. 1). In that case, a displacement w towards the line of axis z is a plate bending deflection. Let analyzed the plate with rigid fix along edges. At $t \leq 0$ the plate is under stressless and strainless state, but at moment of time $t = 0$ the plate is impacted by a load, which have a mass M and velocity \mathbf{v}_0 .

The velocity vector \mathbf{v}_0 is directed at right angle to the centre surface of plate plane. In other words the problem of load impact to plate in point with coordinates $x = a/2, y = b/2$ is considered.

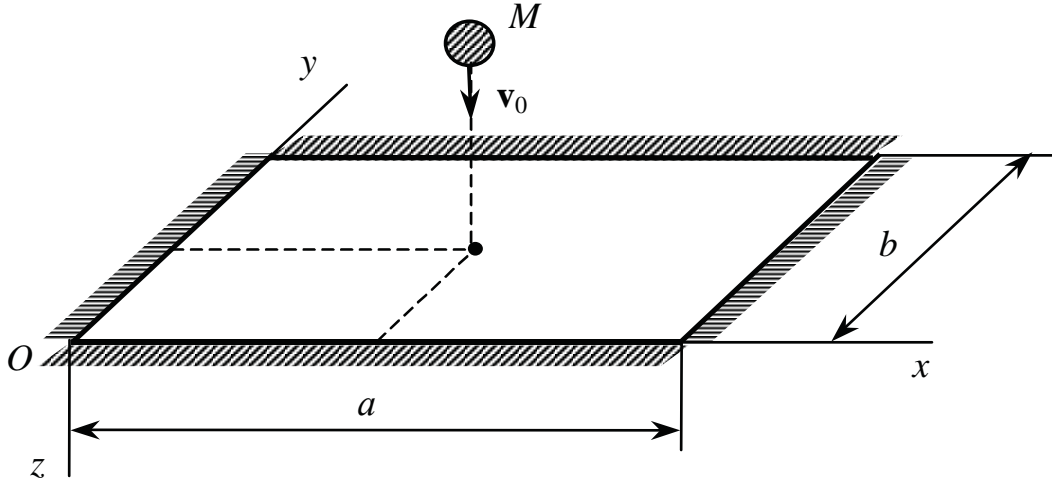

Fig. 1. Problem design diagram

3. The basic statement of studying

The differential equation of induced transversal oscillations of a plate is presented in following view:

$$D \left(\frac{\partial^4 w}{\partial x^4} + 2 \frac{\partial^4 w}{\partial x^2 \partial y^2} + \frac{\partial^4 w}{\partial y^4} \right) + m \frac{\partial^2 w}{\partial t^2} = q(x, y, t), \quad (1)$$

where:

$$D = \frac{Eh^3}{12(1-\nu^2)},$$

D - cylindrical rigidity of plate,

h - plate thickness,

E - modulus of elasticity (Young's modulus),

ν - Poisson's ratio,

w - vertical deflection,

m - plate unit area mass ($m = \gamma h/g$),

γ - relative density of plate material,

g - gravitational acceleration.

The initial conditions of the problem are:

$$w = 0 \quad \text{and} \quad \frac{\partial w}{\partial t} = 0 \quad \text{at} \quad t = 0. \quad (2)$$

Due to plate rigid fixing along its perimeter the boundary conditions will be in following view:

$$\begin{aligned}
 w = 0 \quad \text{and} \quad \frac{\partial w}{\partial x} = 0 \quad \text{at} \quad x = 0 \quad \text{and} \quad x = a \\
 w = 0 \quad \text{and} \quad \frac{\partial w}{\partial y} = 0 \quad \text{at} \quad y = 0 \quad \text{and} \quad y = b
 \end{aligned} \tag{3}$$

It is practically impossible to obtain strong analytical solution for the equation (1), which would be met the initial conditions (2) and boundary condition (3). Therefore, it is expedient for put problem solving to apply the approximate analytical and numerical methods.

For solution of denoted problem concerning load impact to the plate we used a numerical method, which is based on the finite element method (FEM) in form of displacement.

The theorem of mass point momentum alteration at impact is represented in following view:

$$M(\mathbf{v}_1 - \mathbf{v}_0) = \sum S_j, \tag{4}$$

i.e. mass point momentum alteration during impact is equalled to sum of impact momentums acting to the mass point.

There $\mathbf{v}_0, \mathbf{v}_1$ are accordingly velocity of the impacted load at the beginning and the end of impact.

The formula (4) could be written by axis z projection in following view:

$$M(1+k)v_{0z} = \sum S_{jz}, \tag{5}$$

where:

k - restoring coefficient under impact.

Impact momentum is:

$$\mathbf{S}_{\text{imp}} = \int_0^{\tau} \mathbf{F}_{\text{imp}} dt = \mathbf{F}_{\text{imp}}^{\text{av}} \cdot \tau, \tag{6}$$

where:

\mathbf{F}_{imp} - impact force,

τ - time of momentum duration.

Usually it is accepted that:

$$\tau = 2,5T_1 = 2,5 \frac{2\pi}{\omega_1}, \tag{7}$$

where:

ω_1 - first circular frequency of plate natural oscillation.

Based on formulae (6) and (7) was obtained:

$$F_{\text{imp}(z)}^{\text{av}} = \frac{M(1+k)v_{0z}}{\tau}. \tag{8}$$

It is assumed in formula (8) that only one impact occurs (without repetition).

The impacting force, which should be applied to plate during time τ , is defined by formula (8). In our case the load intensity $q(x,y,t)$, that is included to equation (1), will be in following view:

$$q(x, y, t) = F_{\text{imp}(z)}^{\text{av}} \delta\left(x - \frac{a}{2}\right) \delta\left(y - \frac{b}{2}\right) \varphi(t), \quad \varphi(t) = \begin{cases} 1 & \text{at } 0 \leq t \leq \tau \\ 0 & \text{at } t > \tau \end{cases}, \quad (9)$$

where:

$\delta(x)$ - delta-function.

The references [1, 2, 3] are dedicated to impact load theory. The up-to-date results concerning impact calculations are presented in references [4...9].

4. The plates under impact of a mass point

The developed procedure is illustrated by a calculation example of steel plate, design diagram of which shown in Fig. 2.

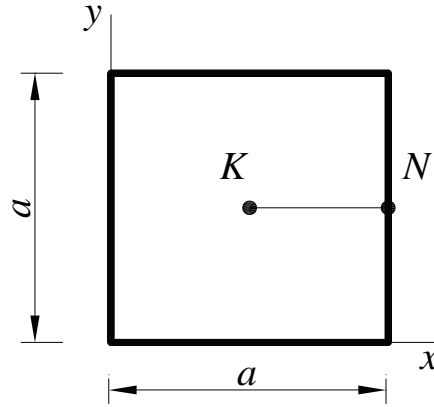

Fig. 2. Design diagram of plate

The analysis of stress-strain state of the structure member, caused by impact load of different level intensity at a constant view form of impact momentum, was fulfilled applying FEM.

The plate dimensions are: side $a = 1$ m and thickness $h = 1.25$ cm. It is made of low-carbon steel with following properties: $E = 2.1 \times 10^5$ MPa; $\nu = 0.28$; $\gamma = 77$ kN/m³.

The plate is rigid fixed along its perimeter and modelled by uniform finite-elements mesh (finite-elements quantity are 100 and quantity of mesh nodes are 121).

The impact of load occurred at point K with coordinates $x = y = a/2 = 0.5$ m. The plate circular frequencies of natural oscillations $\omega_1 = 692.772$ s⁻¹, $\omega_2 = \omega_3 = 1408.08$ s⁻¹ were taken into account.

The time $\tau = 0.023$ s of impact momentum duration at first circular frequency of plate natural oscillation was considered.

Analyzing of the calculation results a symmetrical distribution of member stress-strain state was considering as well.

For the studying plate at load mass $M = 3$ kg and initial impact velocity $v_{0z} = 20$ m/s it is given the fields of deflection intensities distribution w for plate central surface (Fig. 3) and the fields for main σ_1 , σ_3 and equivalent σ_{eq} stresses for the plate based layer (Fig. 4, 5).

The analysis of the plate stress-strain state under dynamic impact load with different impact momentum intensity is presented in view of plotting some functional relations of the equivalent

stresses level σ_{eq} and deflections w around a zone of extreme values at point K caused by load mass magnitudes that affected into plate (Fig. 6).

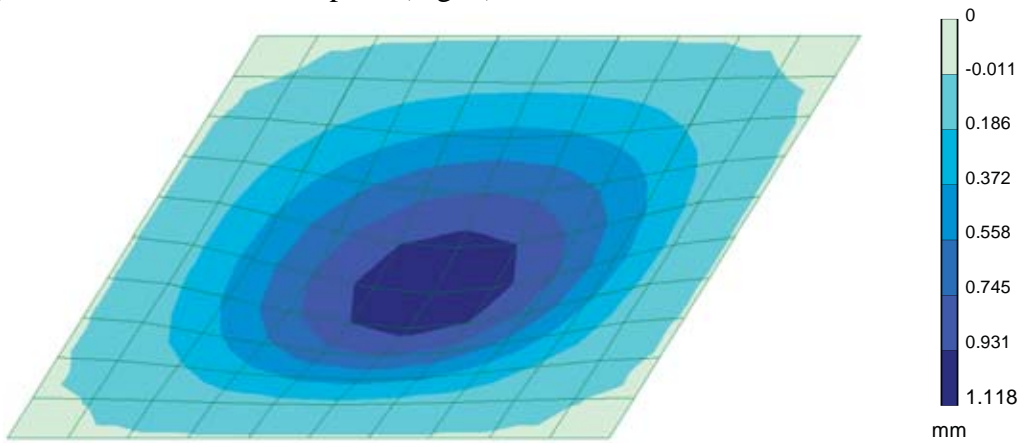

Fig. 3. Fields of deflection intensities distribution w for plate central surface

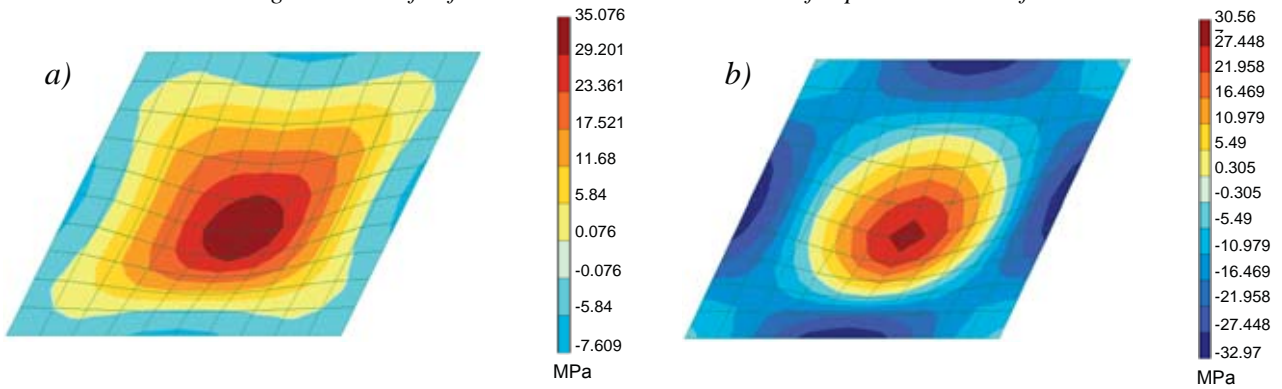

Fig. 4. Stress distribution fields of the plate based layer: a) main stresses σ_1 ; b) main stresses σ_3

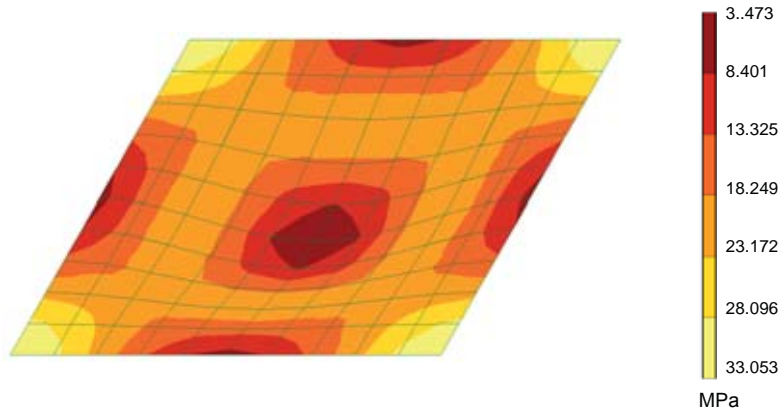

Fig. 5. Stress distribution fields of the plate based layer equivalent stresses σ_{eq}

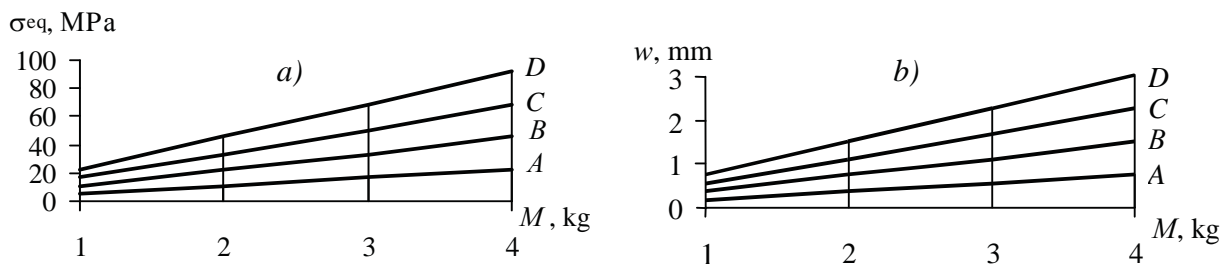

Fig. 6. Relations for $\sigma_{eq} = f(M)$ (a) and $w = f(M)$ (b) at variation of impact initial velocity v_{0z} at point K : A – 10 m/s, B – 20 m/s, C – 30 m/s, D – 40 m/s

While studying influence of impulse view form on structure member stress-strain state it was taken into account the linear (Fig. 7a, b, c) and curvilinear relations (Fig. 7d, e) for impulse loading $F = f(t)$.

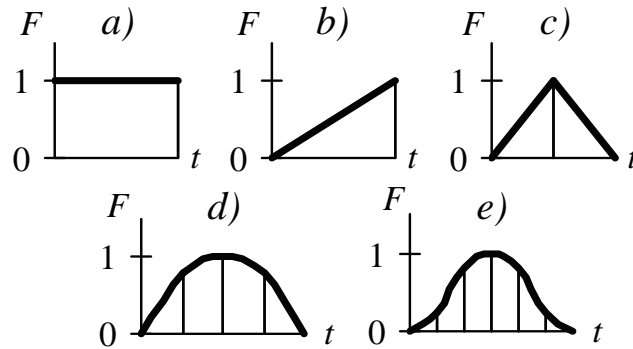

Fig. 7. Impulse form of view

The diagrams of intensity of the deflections w and equivalent stresses σ_{eq} in plate cross-section KN for different impulse view form are presented in Fig. 8 under load mass $M = 3$ kg and impact initial velocity $v_{0z} = 20$ m/s, accordingly.

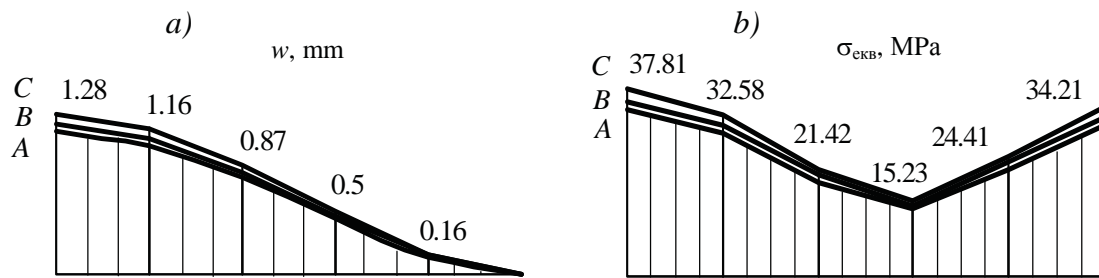

Fig. 8. Deflection (a) and equivalent stress σ_{eq} (b) intensity distribution diagrams in cross-section KN depending on view form of impulse: A – Fig. 7d, B – Fig. 7b; C – Fig. 7c

The comparison of calculation results is given in Tab. 1.

Tab. 1. The dependences w_{max} and σ_{eq} from view form of impulse

	View form of impulse			
	Fig. 7a	Fig. 7d	Fig. 7b	Fig. 7c
w_{max} , mm	1.12	1.14	1.20	1.28
$\sigma_{eq(max)}$, MPa	33.02	33.56	35.40	37.81

5. The plates under impact of a massive body

It was also considered a plate under affecting of a body in the finite dimensions. The impact square is 40×40 cm. A magnitude of impulse load intensity and mass of affecting body were distributed on impact interface area accordingly.

The analysis of structure member stress-strain state was performed at constant view form of impact momentum intensity.

The value of maximum deflection at point K was decreased to $w_{\max} = 0.831$ mm. The deflection distribution diagram onto plate surface is given in Fig. 9.

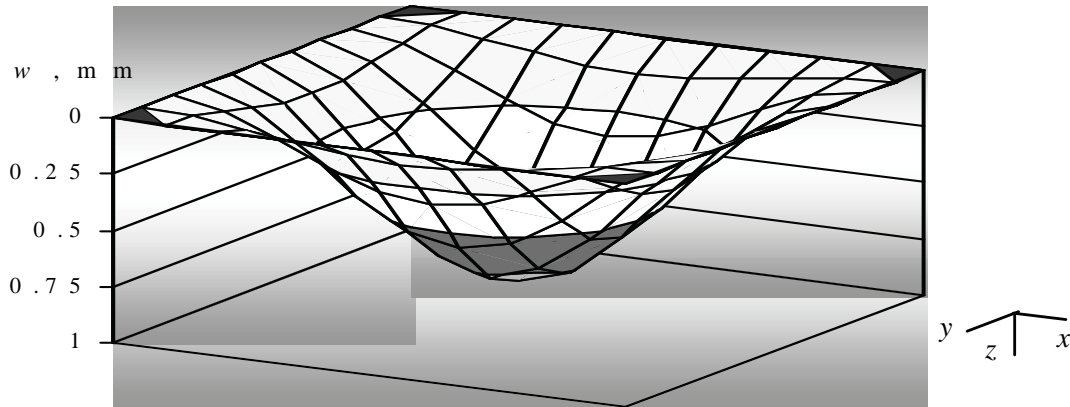

Fig. 9. The diagram of plate's deflections

The maximum equivalent stress in our case occurred at the point N (see. Fig. 2) and equals to $\sigma_{\text{eq}(\max)} = 23.25$ MPa that proves a distribution of maximum stress intensity towards external plate contour.

The distribution field of the plate equivalent stresses σ_{eq} is given in Fig. 10.

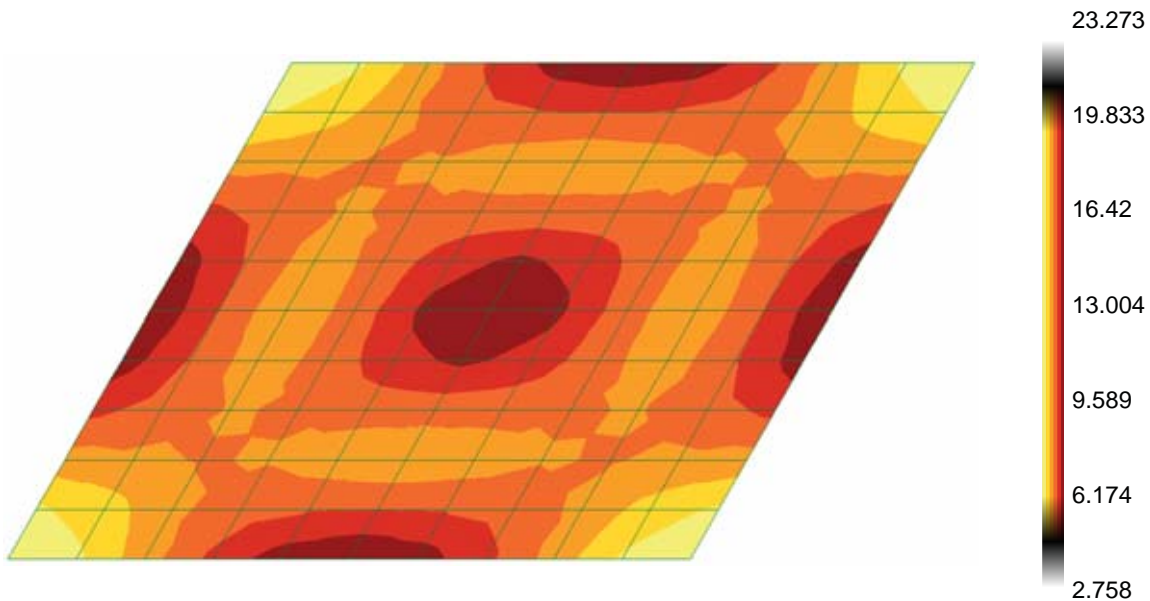

Fig. 10. The stress field σ_{eq} of the plate caused by impact body of finite dimensions

6. The damages of plate caused by impact loadings

For the maintenance practice of sheet structure members the issues related to appearance of damages on structure surface due to material corrosion and others causes are acture. The damages of such types often occur during operation of the aircrafts, ground-based machinery and military equipment.

This problem takes on special significance in cases when dynamic loadings occurs, for instance at impacting the damage sheet structures by bodies with significant intensity of impact momentum due to a great body mass or impact velocity.

The analysis of plate stress-strain state with damage area of 40×40 cm at its centre and thickness of $h = 0.5$ cm under constant view form of impact momentum intensity is illustrated by fields of its deflections (Fig. 11) and equivalent stresses (Fig. 12).

7. The plates with strengthening ribs under impact loadings

The effect of presence strengthening ribs in various cross-sections and its locations in area extend of plate was investigated. The stress-strain state variation due to failure one or several ribs were considered as well. The presence of damages in plate web also was analyzed.

It was considered a plate with stringers during action of mass point impact at the centre of plate under following conditions: $a = 1$ m, $b = 1.6$ m, $c = 0.4$ m, $d = 0.8$ m; two stringers in cross-section dimensions $50 \times 50 \times 3$ mm (Fig. 13).

The analysis of structural member stress-strain state under constant view form of impact momentum intensity was performed.

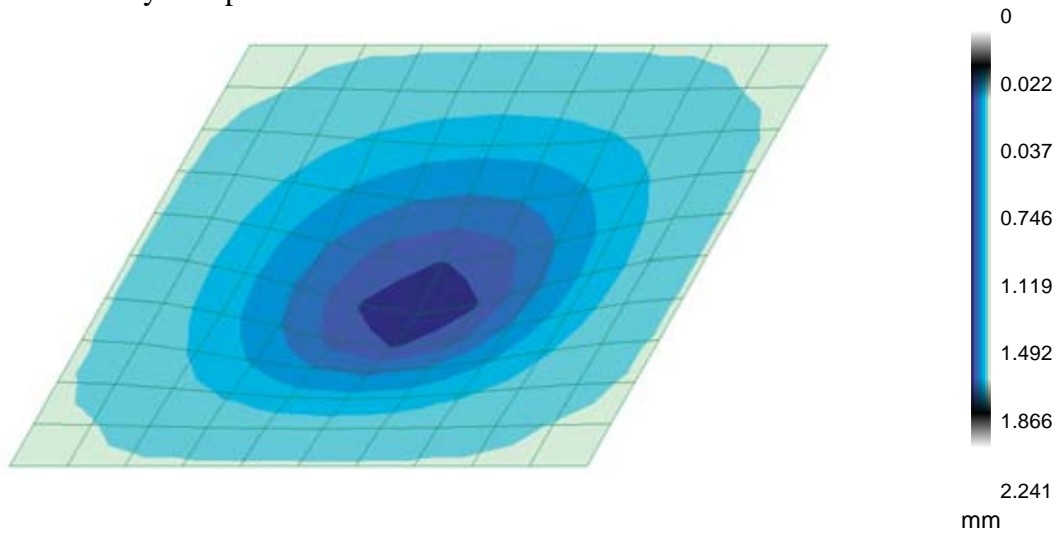

Fig. 11. The field of deflection intensity distributions w for damage plate

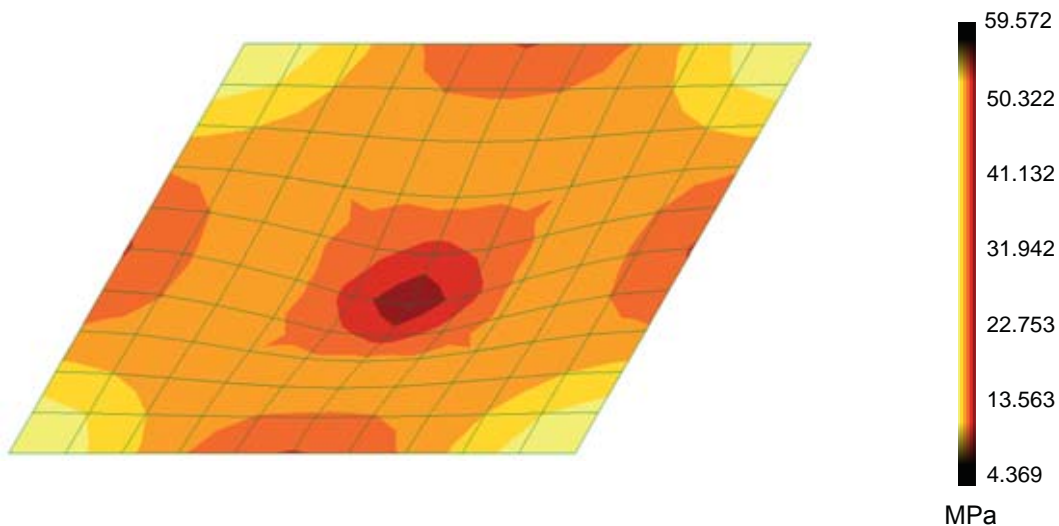

Fig. 12. The field of equivalent stress intensity distributions σ_{eq} for damage plate

The value of maximum deflection at point K comes to $w_{max} = 2.244$ mm. The field of deflection intensity distribution onto plate surface is presented in Fig. 14. The field of equivalent stresses σ_{eq} intensity distribution of the plate based layer is presented in Fig. 15.

During analysis of damages in plate web the defects in the plate centre of dimensions 40×40 cm and deep of 2.5 mm and 5 mm were considered.

The extreme values of deflections of the plate central surface w_{max} and equivalent stresses $\sigma_{eq(max)}$ of plate based layer depend on damage deep are given in Tab. 2. Corresponding diagrams of the plate equivalent stresses σ_{eq} in central cross section along axis x are shown in Fig. 16.

8. Conclusions

Based on results of numerical analysis performed applying presented approach one may formulate the following statements:

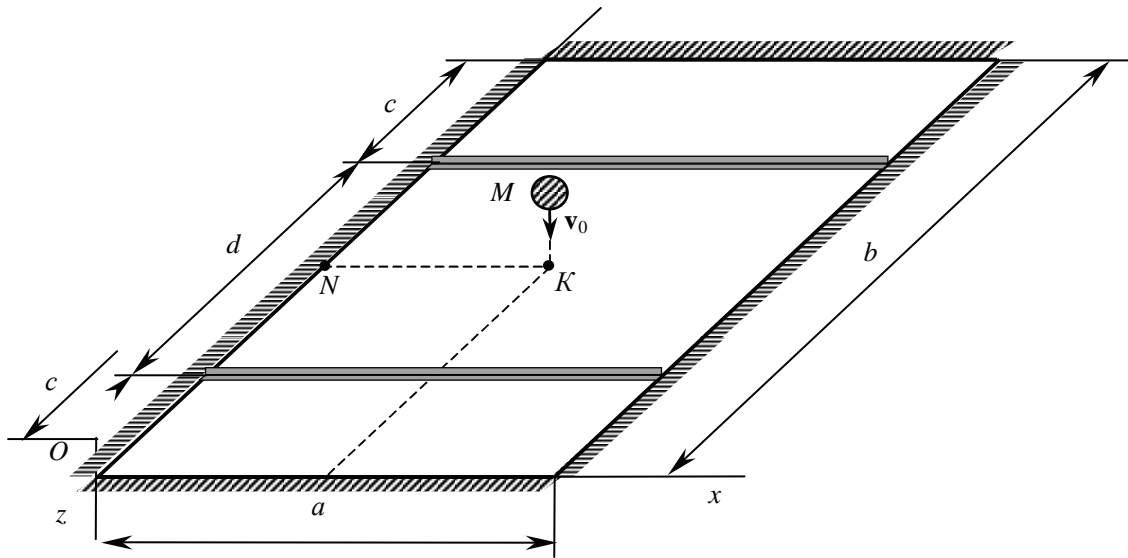

Fig. 13. The structure diagram of plate with stringers

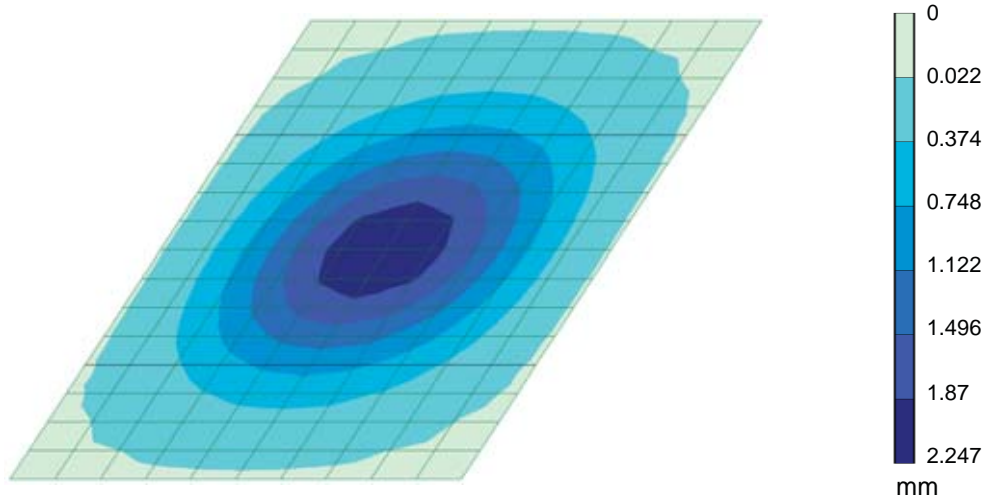

Fig. 14. The deflection field of plate with stringers

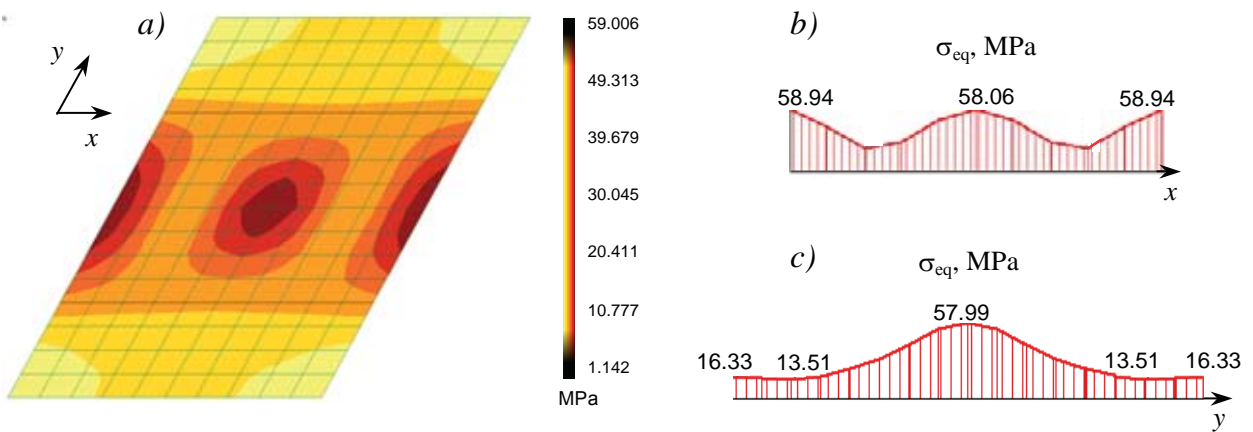

Fig. 15. Distribution of equivalent stresses σ_{eq} : a) in plate with stringers; b) in central cross-section along axis x ; c) in central cross-section along axis y

1. It is suggested an effective procedure, which enables sufficiently solving the problems concerning impact action of load, and that is based on FEM and impact theory, for analysis of plate formed structures.
2. The influence of impact momentum view form was studied (four cases were analyzed). Here discovered that the most dangerous is impact momentum view form presented in Fig. 7c).
3. Performed calculations demonstrated that considering dimensions of the impacting body leads to decreasing of the values of dynamic deflections and equivalent stresses.

Tab. 2. The dependences w_{\max} and σ_{eq} from deep of damage

	Deep of damage, mm		
	0	2.5	5
w_{\max} , mm	2.244	2.962	4.18
$\sigma_{eq(\max)}$, MPa	58.94	73.797	101.829

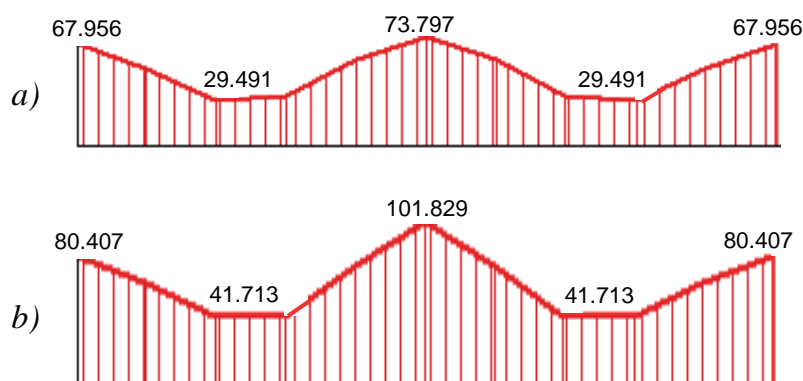

Fig. 16. Diagrams of equivalent stresses σ_{eq} (MPa) of plate with stringers in central cross-section along axis x at damage deeps: a) 2.5 mm; b) 5 mm

4. The influence of plate corrosion damages was studying as well. The analysis of stress-strain state shown that under decreasing of plate thickness at damage area up to 40% the maximum deflection value increased to 100.5% and equivalent stress increased to 80.2%.
5. The effect of strengthening ribs on stress-strain state of structure member was studied.
6. The influence of corrosion damages on plate with stringers was analyzed also.

The obtained results may be applied for analysis of the sheet structure members' stress-strain state under action of impact loading.

References

- [1] Goldsmith, V., *Udar*. M., Stroiizdat, c. 448, 1965.
- [2] Kharris, S. M., Kriz, Ch. I., *Spravochnik po udarnym nagruzkam*, L., Sudostroenie p. 359, 1980.
- [3] Timoshenko, S. P., Yang, D. Kh., Uiver, U., *Kolebaniya v inzhenernom dele*, M., Mashinostoenie, p. 472, 1985.
- [4] Akimov, A. A., Prostranstvennoe modelirovanie soudareniya kompaktnogo elementa s pregradoi metodom sglazhennykh chastits, 9 Vseros. Syezd po Teor. i Prikl. Mekhanike, Annotatsii Dokladov, T. 3, Nizhn. Novgorod, Izd-vo NAGU, p. 11, 2006.

- [5] Radchenko, P. A., *Chislennyi analiz vysokoskorostnogo vzaimodeistviya anizotropnykh tel*, Fizika i Khimiya Nanomaterialov, Sb. Mater. Mezhd. Shkoly-konf., Tomsk, Izd-vo Fizika i Khimiya Nanomaterialov, Sb. Mater. Mezhd. Shkoly-konf., Tomsk, Izd-vo TGU, p. 442-445, 2005.
- [6] Sburlati, R., *An exact solution for the impact law in thick elastic plates*, Int. J. Solids and Struct, Vol. 41, No. 9-10, pp. 2539-2550, 2004.
- [7] Gao Zhen, Gu Yong-ning, Hu Zhi-giang, *Impact strength analysis of ship hull*, Shanghai Jiao Tong University, China, Chanbo lixue, J. Ship Mech., Vol. 9, No. 2, 2005.
- [8] Onishchenko, A. V., *Povrezhdaemost plastin pri deistvii udarnykh nagruzok*, Mater. 4-oi Mezhd. Nauchn. Konf., pp. 283-285, Donetsk, Yugo-Vostok Ltd 2006.
- [9] Orlov, A. S., Shatrov, A. K., *Raschetno-eksperimentalnaya otsenka nagruzheniya kosmicheskikh apparatov pri vysokointensivnykh impulsnykh vozdeistviyakh*, Vestnik Sib. Gos. Aerokosm. Un-Ta, No. 6, pp. 153-155, 2005.

