

## HYDROPNEUMATIC SUSPENSION MODELLING FOR WHEELED ARMoured FIGHTING VEHICLE

Sebastian Ławniczak, Przemysław Simiński

Military Institute of Armour and Automotive Technology  
Okuniewska Street 1, 05-070 Sulejów, Poland  
phone: +48 22 6811204, fax: +48 226811073  
e-mail:psiminski@tlen.pl

### Abstract

The paper shall present the way for building a model for simulation studies of the wheeled armoured fighting vehicle with hydropneumatic suspension of driving wheels axles. Thus developed model shall be used to conduct simulation studies in the area of the vehicle safety. The scope of terms and conditions for applications of hydropneumatic suspensions in wheeled armoured fighting vehicles is justified due to a number of their advantages, such as: progressive characteristics of elasticity provides great driving comfort with a small load, as well as a possibility of placing a considerable load on the vehicle (the requirements are mutually exclusive in classical suspension). Compressed nitrogen, sealed in the sphere using an elastic diaphragm, is approximately six-fold more flexible than steel springs elements at static load of the suspension, which provides high level of driving comfort; a possibility to lower the height of the vehicle by changing the road clearance which effects in e.g. higher availability for airborne transport and so on. However, they are not free from disadvantages; therefore, it is the studies of their justified use, especially related to traffic safety, that should have a final say in individual cases.

The hereto presented model of hydropneumatic suspension and the vehicle motion model are applied to assess dynamic capabilities and evaluate the real object motion safety.

**Keywords:** transport, AFV vehicle, hydropneumatic suspension system, modelling

### 1. Hydropneumatic Suspension Capabilities

Here are advantages of hydropneumatic suspension in applications for military vehicles:

- progressive characteristics of elasticity provides great driving comfort with a small load, as well as a possibility of placing a considerable load on the vehicle (the requirements are mutually exclusive in classical suspension). Compressed nitrogen, sealed in the sphere using an elastic diaphragm, is approximately six-fold more flexible than steel springs elements at static load of the suspension, which provides high level of driving comfort,
- a possibility to lower the height of the vehicle by changing the road clearance which effects in e.g. higher availability for airborne transport,
- a possibility to increase the road clearance what gives higher cross-country driving ability,
- there is possibility of the suspension self-levelling,
- compact casing of hydropneumatic column,
- suspension servicing is relatively simple (but requiring training for maintenance crews),
- relatively low cost of mass production,
- in many cases there is a lower unsprung mass of the vehicle,
- capabilities of the suspension decide about better roll-over resistance of the vehicle while curvilinear motion (higher resistance to roll-over). It is especially important in the event of heavy vehicles,
- possible horizontal positioning of the hydropneumatic column in the rear suspension of the vehicle (a saving of space that may be allocated building in some other special gear, or it may enlarge the loading or assault space capacity).

Disadvantages of hydropneumatic suspension:

- requires specialised service and maintenance support as well as trained personnel,
- repair of hydropneumatic suspension is costly, especially when a need arises to replace some of its parts as a result of maintenance negligence,
- a damage of hydraulic system may disable driving or considerably limit (reduce) road clearance of the vehicle.

## 2. General Assumptions for AFV Vehicle Model with Hydropneumatic Suspension

For the AFV vehicle model, a hydropneumatic suspension model was proposed based on components used in modern trucks and passenger cars. Fig. 1 presents a diagram of the hydropneumatic suspension system with specification of key elements – responsible for performance of a function responsible for transferring dynamic vertical loads from the driving wheels axle, through hydraulic column, onto the AFV vehicle body.

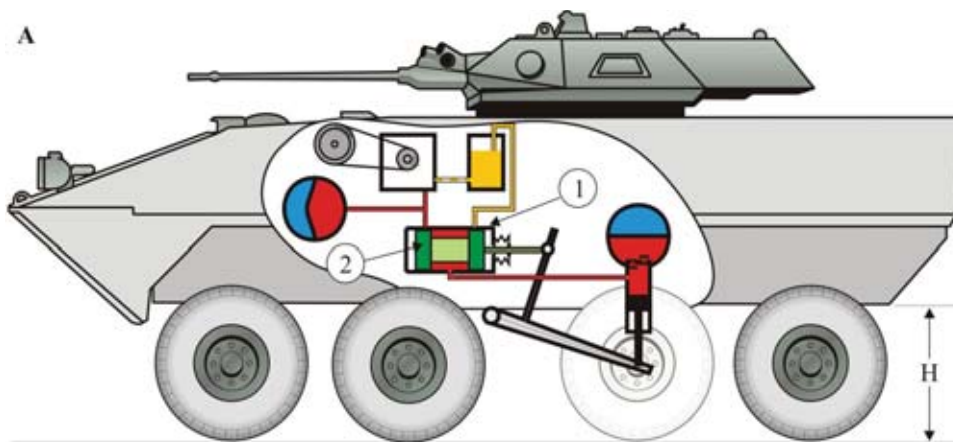

Fig. 1. General diagram of hydropneumatic suspension system in view of the vehicle

The main subassemblies of the executive system that is in charge of performance of the basic functions of the suspension include:

- hydropneumatic column,
- hydraulic cylinder,
- pneumatic spring element,
- damper orifice,
- liquid tanks,
- feeding pump,
- vehicle body height controller,
- vehicle body height controlling valve,
- hydraulic leads (of high and low pressure).

Some assumptions were made before starting preparation of the model. A decision was made to consider only the processes occurring operation of the suspension in vertical direction. The wheel leading elements (i.e. walking beams) modelled as non-deformable, zero-mass and linked by nodes with the vehicle body and the hydropneumatic column.

Extortion, affecting the vehicle suspension system, is the progress of the road longitudinal irregularities height, or any other external (e.g. wind blow) or internal extortion originating e.g. from the force of the vehicle body's response to a cannon shell discharge, etc.

Response of the model is the time runs of values of the selected physical quantities being characteristic of the vehicle model motion (including operation of the suspension elements). Block diagrams are illustrated on Fig. 3 and 4.

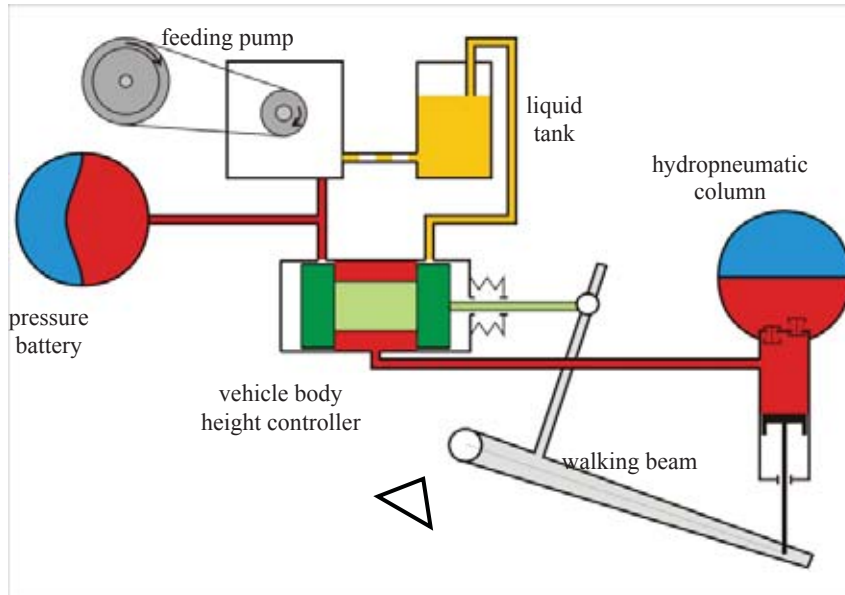

Fig. 2. Diagram of hydropneumatic suspension system

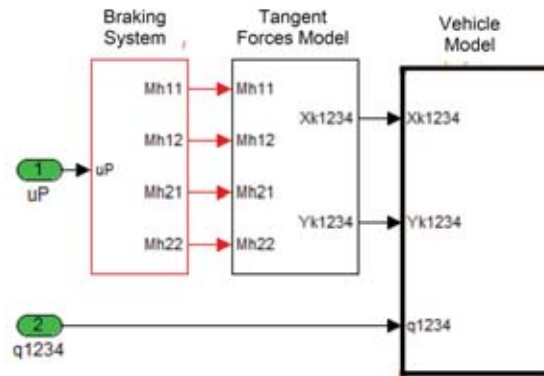

Fig. 3. Simulation model – main blocks structure Markings:  $uP$  – relocation of brake pedal,  $q1234$  – longitudinal road profile under the wheels of axle 1,2 ... 4

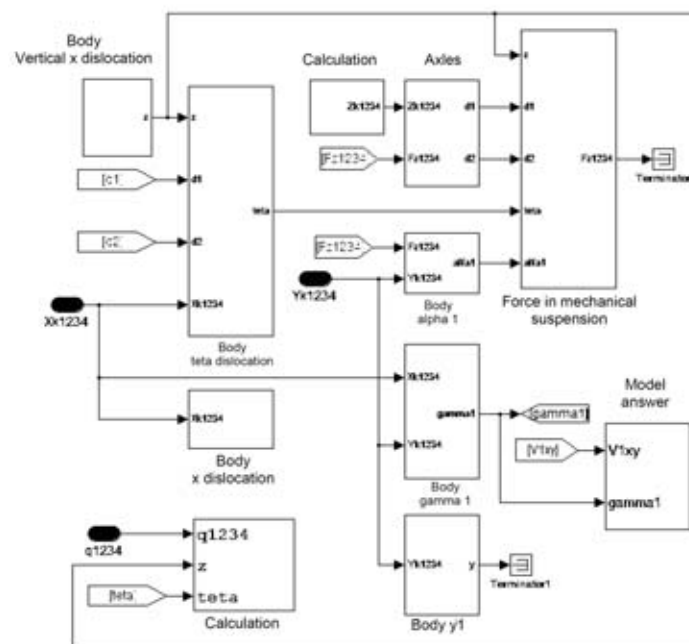

Fig. 4. Vehicle Model – main blocks structure

### **3. Detailed Assumptions and Simplifications Adopted while Modelling Operational Dynamics of Hydropneumatic Suspension**

Here are essential elements that are subjects for modelling, and that influence the capabilities of hydropneumatic suspension:

- actuator, consisting of a piston fixed to driving axle (of mass  $m$ ) and a hydraulic cylinder fixed to vehicle body (of mass  $M$ ),
- damper orifice,
- spring element, consisting of a tank in which working gas – the nitrogen is separated from the working liquid (mineral oil) with elastic diaphragm. Thanks to its elasticity, the diaphragm can equalize pressure between two chambers.

The following was taken into consideration in the model:

- spring capabilities of hydropneumatic suspension;
- damping capabilities of hydropneumatic suspension;
- and a possibility for its further development towards cooperation of the hydropneumatic column with high control valve controlling the height of the vehicle body position and the suspension controller algorithm (a possibility to operate in semi-automatic mode).

When building the model, the following assumptions were made:

- pressure battery was modelled as a source of indefinitely large energy of hydraulic liquid under a steady pressure  $p_{ZASIL}$ ;
- friction resulting from the piston motion in the hydraulic cylinder was not taken into consideration;
- mass of the piston, piston rod and the diaphragm mass were not taken into consideration;
- operational dynamics of valves, deciding about damping capabilities (their inertia while their closing and opening was disregarded), was not taken into consideration;
- hydraulic leads were substituted by respective hydraulic resistances;
- the hydraulic leads discharge capacity coefficients were adopted as fixed;
- heat exchange with the environment has been disregarded, assuming a steady temperature of hydraulic liquid.

Sets of equations describing capabilities of the mathematical model were presented in subsequent subsections of the statement. The numerical model was developed using the MATLAB – SIMULINK software platform.

The following was disregarded in the model:

- a phenomenon of operating liquid outflow from the suspension column as a result of leaks between the piston and the column cylinder – assuming that the link ideally sealed;
- a phenomenon of working gas loss, as a result of its permeation into the operating liquid or a loss through leakage in inlet adaptor allowing gas into spherical spring element.

Mathematical description of the model involves making mathematical equations including:

- equations describing operation of movable elements;
- equations of liquid flow pressure losses in hydraulic elements;
- balance equations of temporary mass liquid streams (nodes equations or peripherals equations).

### **4. Hydropneumatic Suspension Column Model**

Figure 5 presents computational diagram of the hydropneumatic suspension column.

When formulating mathematical equations [6] of the hydropneumatic suspension column model, the following assumptions and simplifications were made:

- viscosity, density and temperature of liquid are not subject to change in duration of the transitional process,
- forces of the piston viscous friction in the cylinder are disregarded due to their small values,

- the liquid is incompressible, and the working liquid pressure transferring elements are rigid and are non-deformable as affected by motion or change of the pressure,
- the liquid stream is continuous.

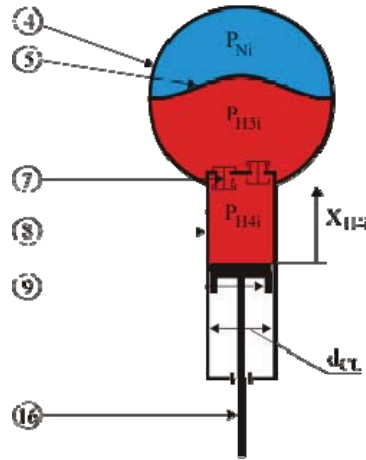

Fig. 5. Computational diagram of hydropneumatic suspension column, Markings: 4 - pneumatic spring element, 5 - diaphragm, 7 - damper orifice, 8 - hydraulic cylinder, 9 - piston, 16 - piston rod

#### 4.1. Determination of Initial Conditions

In pneumatic spring element in static load conditions, the following equality occurs:

$$p_{Ni} = \frac{Z_i}{S_{MB}}. \quad (1)$$

Thus, it can be written as:

$$p_{N1} = M_N \cdot g \cdot \frac{b}{L} \cdot \frac{1}{S_{MB}}, \quad (2)$$

and using the adiabatic transformation equation:

$$V_{N1} = V_{01} \cdot \sqrt[\kappa]{\frac{p_{01}}{p_{N1}}}, \quad (3)$$

and analogically:

$$p_{N2} = M_N \cdot g \cdot \frac{a}{L} \cdot \frac{1}{S_{MB}}, \quad (4)$$

$$V_{N2} = V_{02} \cdot \sqrt[\kappa]{\frac{p_{02}}{p_{N2}}}, \quad (5)$$

where:

$$S_{MB} = \frac{\pi \cdot d_{MB}^2}{4}. \quad (6)$$

#### 4.2. Equation of Liquid Pressure Balance in Hydraulic System

General equation of the liquid pressure balance is presented as follows:

$$p_{H5} = p_{H4} \pm p_{HM4-5}, \quad (7)$$

- at compression

$$p_{H5} = p_{H4} - p_{HM4-5}, \quad (8)$$

- at expansion

$$p_{H5} = p_{H4} + p_{HM4-5}, \quad (9)$$

where:

$$p_{H4} = \frac{F_{HP}}{S_{CL}}, \quad (10)$$

$$S_{CL} = \frac{\pi \cdot d_{CL}^2}{4}. \quad (11)$$

Using the rule of pressure balance (of the liquid under the diaphragm and nitrogen above the diaphragm) in a steady state can be written as:

$$p_{H5} = p_{H4} = p_{N5}(t) = p_{N1} \cdot \left( \frac{V_{N1}}{V_{N1} - \Delta V(t)} \right)^\kappa, \quad (12)$$

$$\Delta V(t) = S_{CL} \cdot x_{H4i}, \quad (13)$$

$$x_{H41} = -z + \vartheta \cdot a + z_1, \quad (14)$$

$$x_{H42} = -z - \vartheta \cdot b + z_2, \quad (15)$$

$$p_{HM4-5} = \xi_{4-5} \cdot \frac{\rho}{2} \cdot \left( \frac{dy_{4-5}}{dt} \right)^2, \quad (16)$$

$$\frac{dy_{4-5}}{dt} \cdot S_{C-E} = \frac{dx_{H4i}}{dt} \cdot S_{CL}, \quad (17)$$

$$\frac{dy_{4-5}}{dt} = \frac{dx_{H4i}}{dt} \cdot \frac{S_{CL}}{S_{C-E}}, \quad (18)$$

$$p_{HM4-5} = \xi_{4-5} \cdot \frac{\rho}{2} \cdot \left( \frac{dx_{H4i}}{dt} \cdot \frac{S_{CL}}{S_{C-E}} \right)^2, \quad (19)$$

for compression

$$p_{HM4-5} = \xi_{4-5} \cdot \frac{\rho}{2} \cdot \left( \frac{dx_{H4i}}{dt} \cdot \frac{S_{CL}}{S_C} \right)^2, \quad (20)$$

for expansion

$$p_{HM4-5} = \xi_{4-5} \cdot \frac{\rho}{2} \cdot \left( \frac{dx_{H4i}}{dt} \cdot \frac{S_{CL}}{S_E} \right)^2, \quad (21)$$

where:

$$S_C = \frac{\pi \cdot (d_C^2 + d_{CE}^2)}{4}, \quad (22)$$

$$S_E = \frac{\pi \cdot (d_E^2 + d_{CE}^2)}{4}, \quad (23)$$

and substituting for

$$p_{H4i} = p_{Ni} \cdot \left( \frac{V_{Ni}}{V_{Ni} - \Delta V(t)} \right)^\kappa \pm \xi_{4-5} \cdot \frac{\rho}{2} \cdot \left( \frac{dx_{H4i}}{dt} \cdot \frac{S_{CL}}{S_{C-E}} \right)^2, \quad (24)$$

and following the substitution

$$p_{H4i} = p_{Ni} \cdot \left( \frac{V_{Ni}}{V_{Ni} - S_{CL} \cdot x_{H4i}} \right)^\kappa \pm \xi_{4-5} \cdot \frac{\rho}{2} \cdot \left( \frac{dx_{H4i}}{dt} \cdot \frac{S_{CL}}{S_{C-E}} \right)^2. \quad (25)$$

In particular for the front suspension:

- upward movement of the piston (compression phase)

$$p_{H41} = p_{N1} \cdot \left( \frac{V_{N1}}{V_{N1} - S_{CL} \cdot x_{H41}} \right)^\kappa + \xi_{4-5} \cdot \frac{\rho}{2} \cdot \left( \frac{dx_{H41}}{dt} \cdot \frac{S_{CL}}{S_C} \right)^2, \quad (26)$$

$$p_{H51} = p_{N1} \cdot \left( \frac{V_{N1}}{V_{N1} - S_{CL} \cdot x_{H41}} \right)^\kappa - \xi_{4-5} \cdot \frac{\rho}{2} \cdot \left( \frac{dx_{H41}}{dt} \cdot \frac{S_{CL}}{S_C} \right)^2, \quad (27)$$

- downward movement of the piston (expansion phase)

$$p_{H41} = p_{N1} \cdot \left( \frac{V_{N1}}{V_{N1} - S_{CL} \cdot x_{H41}} \right)^\kappa - \xi_{4-5} \cdot \frac{\rho}{2} \cdot \left( \frac{dx_{H41}}{dt} \cdot \frac{S_{CL}}{S_E} \right)^2, \quad (28)$$

$$p_{H51} = p_{N1} \cdot \left( \frac{V_{N1}}{V_{N1} - S_{CL} \cdot x_{H41}} \right)^\kappa + \xi_{4-5} \cdot \frac{\rho}{2} \cdot \left( \frac{dx_{H41}}{dt} \cdot \frac{S_{CL}}{S_E} \right)^2, \quad (29)$$

for the rear suspension

- upward movement of the piston (compression phase)

$$p_{H42} = p_{N2} \cdot \left( \frac{V_{N2}}{V_{N2} - S_{CL} \cdot x_{H42}} \right)^\kappa + \xi_{4-5} \cdot \frac{\rho}{2} \cdot \left( \frac{dx_{H42}}{dt} \cdot \frac{S_{CL}}{S_C} \right)^2, \quad (30)$$

$$p_{H52} = p_{N2} \cdot \left( \frac{V_{N2}}{V_{N2} - S_{CL} \cdot x_{H42}} \right)^\kappa - \xi_{4-5} \cdot \frac{\rho}{2} \cdot \left( \frac{dx_{H42}}{dt} \cdot \frac{S_{CL}}{S_C} \right)^2, \quad (31)$$

- downward movement of the piston (expansion phase)

$$p_{H42} = p_{N2} \cdot \left( \frac{V_{N2}}{V_{N2} - S_{CL} \cdot x_{H42}} \right)^\kappa - \xi_{4-5} \cdot \frac{\rho}{2} \cdot \left( \frac{dx_{H42}}{dt} \cdot \frac{S_{CL}}{S_E} \right)^2, \quad (32)$$

$$p_{H52} = p_{N2} \cdot \left( \frac{V_{N2}}{V_{N2} - S_{CL} \cdot x_{H42}} \right)^\kappa + \xi_{4-5} \cdot \frac{\rho}{2} \cdot \left( \frac{dx_{H42}}{dt} \cdot \frac{S_{CL}}{S_E} \right)^2, \quad (33)$$

therefore, the force affecting the vehicle body is:

$$F_{HP1} = p_{H41} \cdot S_{CL}, \quad (34)$$

$$F_{HP2} = p_{H42} \cdot S_{CL}. \quad (35)$$

Fig. 6 illustrates a diagram of the hydropneumatic suspension column response force acting on the vehicle body.

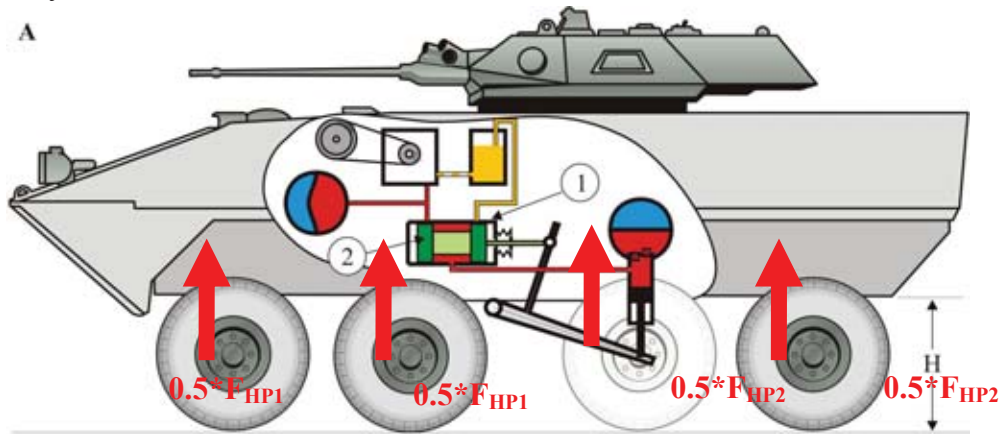

Fig. 6. Diagram of the hydropneumatic suspension column response force acting on the vehicle body

### 4.3. Equation describing operation of the height control valve

- piston-rod motion kinematics equation  $x_{Ti}$ :

$$\operatorname{tg}(\alpha_R) = \frac{l_{R4} - z_1}{l_{R3}}, \quad (36)$$

where in special case by substituting  $z_1=0$ , we obtain an expression for the static angle value:

$$\operatorname{tg}(\alpha_{RSTAT}) = \frac{l_{R4}}{l_{R3}}, \quad (37)$$

that can additionally take the form of:

$$\operatorname{tg}(\alpha_{RSTAT}) = \frac{e_{R1}}{e_{R2}}, \quad (38)$$

thus

$$x_{Ti} = e_{R2} \cdot [\operatorname{tg}(\alpha_{RSTAT}) - \operatorname{tg}(\alpha_R)], \quad (39)$$

and following the substitution:

$$x_{Ti} = e_{R2} \cdot \left( \frac{l_{R4}}{l_{R3}} - \frac{l_{R4} - z_1}{l_{R3}} \right), \quad (40)$$

which following the simplification leads to:

$$x_{Ti} = z_1 \cdot \frac{e_{R2}}{l_{R3}}, \quad (41)$$

- area of valves section:

$$S_{23} = \frac{\pi \cdot (d_{23} - x_{Ti})^2}{4} \quad \text{for } x_{Ti} \in \langle 0, d_{23} \rangle, \quad (42)$$

$$S_{23} = 0 \quad \text{for } x_{Ti} > d_{23}, \quad (43)$$

$$S_{03} = 0 \quad \text{for } x_{Ti} < c_1 - d_{03}, \quad (44)$$

$$S_{03} = \frac{\pi \cdot (x_{Ti} - c_1 + d_{03})^2}{4}, \quad \text{for } x_{Ti} \in \langle c_1 - d_{03}, c_1 \rangle, \quad (45)$$

$$S_{03} = \frac{\pi \cdot (d_{03})^2}{4}, \quad \text{for } x_{Ti} > d_{03}. \quad (46)$$

## 5. Data Matching for Hydropneumatic Suspension Column Model

### 5.1. Gas Spring Rigidity Key Parameters Matching

A role of the spring element in hydropneumatic suspension is performed by the gas spring (pneumatic spring element). Computations of the spring involve determination of its rigidity coefficient:

$$k = \frac{dF_{HPi}}{dx_{4i}}, \quad (47)$$

where:

$$F_{HPi} = p_{H4i} \cdot S_{CL} - \text{force acting on the vehicle body} \quad (48)$$

$$x_{4i} = \frac{V}{S_{CL}} - \text{relocation of piston rod} \quad (49)$$

thus:

$$dF_{HPi} = dp_{H4i} \cdot S_{CL}, \quad (50)$$



$$dx_{4i} = \frac{dV}{S_{CL}}, \quad (51)$$

$$k = \frac{dF_{HPi}}{dx_{4i}} = \frac{dp_{H4i} \cdot S_{CL}}{\frac{dV}{S_{CL}}} = S_{CL}^2 \cdot \frac{dp_{H4i}}{dV}. \quad (52)$$

The change of volume in the gas chamber is:

$$V_1 = V_0 - V. \quad (53)$$

The assumption was made that adiabatic transformation – in which changes are in all gas state parameters, such as: pressure, specific volume, temperature, internal energy, enthalpy, entropy and so on – occurs during operation of the gas spring. Because there is no heat exchange with the environment, gas temperature grows while compression and respectively it drops down while expansion. Moreover, similarly as in the event of isothermal compression, the volume declines and the pressure grows.

Progress of the adiabatic transformation is defined as the Poisson law:

$$p_1 \cdot V_1^\kappa = p_0 \cdot V_0^\kappa, \quad (54)$$

where:

- p – gas pressure
- V – volume taken by gas

Following the transmutation (54):

$$p_1 = p_0 \cdot \frac{V_0^\kappa}{V_1^\kappa}, \quad (55)$$

and following the substitution (53):

$$p_1 = p_0 \cdot \frac{V_0^\kappa}{(V_0 - V)^\kappa}, \quad (56)$$

$$p_1 = \frac{p_0}{\frac{(V_0 - V)^\kappa}{V_0^\kappa}} = \frac{p_0}{\left(1 - \frac{V}{V_0}\right)^\kappa}. \quad (57)$$

And upon differentiating  $p_1$  against  $V$ , we shall obtain:

$$\frac{dp_1}{dV} = \frac{\kappa \cdot p_0}{V_0} \cdot \frac{1}{\left(1 - \frac{V}{V_0}\right)^{\kappa+1}}, \quad (58)$$

and following the substitution to (52), we shall obtain a final form of the expression:

$$k = \frac{S_{CL}^2 \cdot \kappa \cdot p_0}{V_0} \cdot \frac{1}{\left(1 - \frac{V}{V_0}\right)^{\kappa+1}}, \quad (59)$$

and by substituting the expression (49) for  $V$ , we shall obtain:

$$k = \frac{S_{CL}^2 \cdot \kappa \cdot p_0}{V_0} \cdot \frac{1}{\left(1 - \frac{x_{4i} \cdot S_{CL}}{V_0}\right)^{\kappa+1}}. \quad (60)$$

Exemplary characteristic of the elasticity force of the pneumatic spring element in view of the suspension leaf spring elasticity characteristic was presented on Fig. 7.

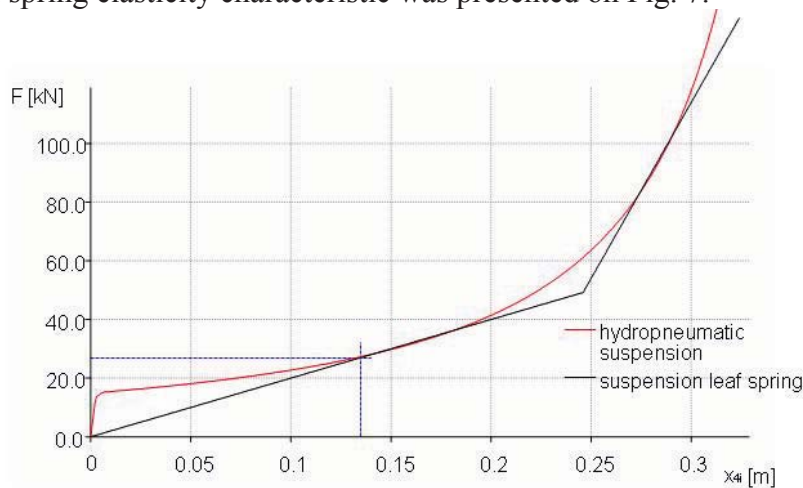

Fig. 7. The progress of spring force value of a single hydropneumatic element (onto one wheel) in a function of the piston rod relocation in hydraulic cylinder (or deflection of suspension). The deflection value and the force of the suspension static load were marked with blue line

Numerical value of the hydraulic friction coefficient for a case of a sudden reduction of the flow section was defined pursuant to [6] on the basis of coefficient dependencies table and based on diameters  $d_1/d_2$  ratio.

Adiabatic exponent  $\kappa$  is equal to the specific heat ratio at steady volume and at steady pressure. Coefficients  $\alpha$  depend on a number of degrees of gas molecules freedom and take the values of:  $3/2$  - for monoatomic gases,  $5/2$  - for diatomic gases, and 3 for polyatomic gases. Nitrogen is a diatomic gas, therefore the coefficient  $\alpha=5/2$ , and  $\kappa=1.4$ .

## 5.2. Matching the parameters deciding about damping capabilities of the hydropneumatic column

The relative damping coefficient is defined as a quotient of the damping coefficient and the critical damping coefficient:

$$\delta_{TL} = \frac{c}{c_{KR}} \quad (61)$$

The coefficient value for typical suspensions of mechanical vehicles is  $\langle 0.2 - 0.3 \rangle$ . For computations in the model, the following value was assumed  $\delta_{TL} = 0.25$ .

Thus, on the basis of dependence (61), the following can be written:

$$c = \delta_{TL} \cdot c_{KR} \quad (62)$$

A dependence that describes the critical damping value is presented below:

$$c_{KR} = 2 \cdot \sqrt{k \cdot m} \quad (63)$$

Thus, after substituting (63) to (62), we obtain:

$$c = 2 \cdot \delta_{TL} \cdot \sqrt{k \cdot m} \quad (64)$$

In order to compute damping coefficient, the value was adopted of the suspension rigidity coefficient in point that corresponds to static deflection of the suspension, and the mass value that

corresponds to the value of mass per single column of the suspension. Upon substituting, the damping coefficient value is illustrated by the equation 65:

$$c = 2 \cdot \delta_{TL} \cdot \sqrt{\frac{S_{CL}^2 \cdot \kappa \cdot p_0}{V_0} \cdot \frac{1}{\left(1 - \frac{x_{4iSTAT} \cdot S_{CL}}{V_0}\right)^{\kappa+1}} \cdot M_N \cdot g \cdot \frac{b}{4 \cdot L}} \quad (65)$$

In order to match parameters ( $d_C$ ,  $d_E$ ) deciding about the hydropneumatic column damping coefficient, its additional model was built (Fig. 8) covering mass element, spring, and damper orifice (of variable damping coefficient). The model was used for determining progresses of the vehicle body mass relocation, caused by the step extortion. Kinematic extortion, which involves dropping of the vehicle from the height of 7 cm onto flat ground, was assumed to be the step extortion. In order to eliminate angular vibrations of the vehicle body, parameters of the vehicle mass distribution were changed so that its centre of mass was placed in the symmetrical centre of the vehicle. Processes of the vehicle body's centre of mass relocation, caused by such extortion and for different values of the model parameters, deciding about damping effectiveness, were illustrated on Fig. 9.

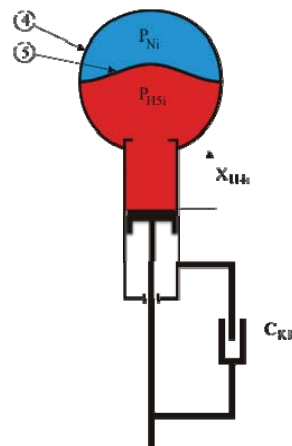

Fig. 8. Simulation model for calibration of hydropneumatic column damping coefficient

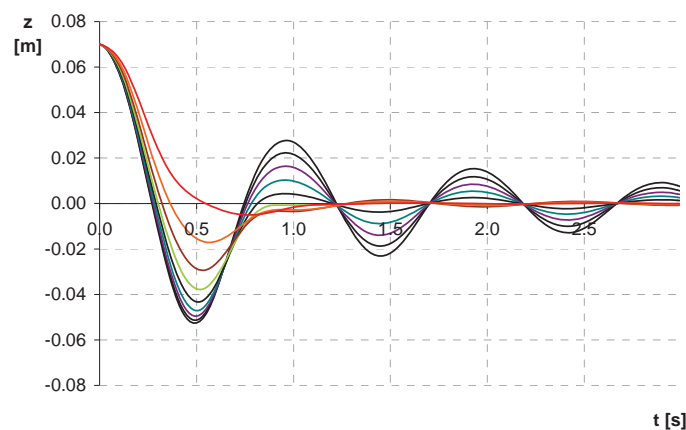

Fig. 9. Progress of vehicle body relocations for various values of parameters ( $d_C$ ,  $d_E$ ) deciding about the hydropneumatic column damping value

The progresses were used to calibrate (match) physical quantities responsible for damping in hydropneumatic column. They include as follows:

- $d_C$  - „compression” damping valve diameter,
- $d_E$  - „rebound” damping valve diameter.

The following  $d_C = 0.005$  [m] and  $d_E = 0.0025$  [m] were adopted for further simulation research studies. Such values of diameters of damper orifice valves ensure the progresses illustrated on Fig. 10, and the latter ones are in turn close (as to their quality) to the progress obtained on the benchmark model of the hydropneumatic column with provided damping coefficient of a value as specified in equation 65.

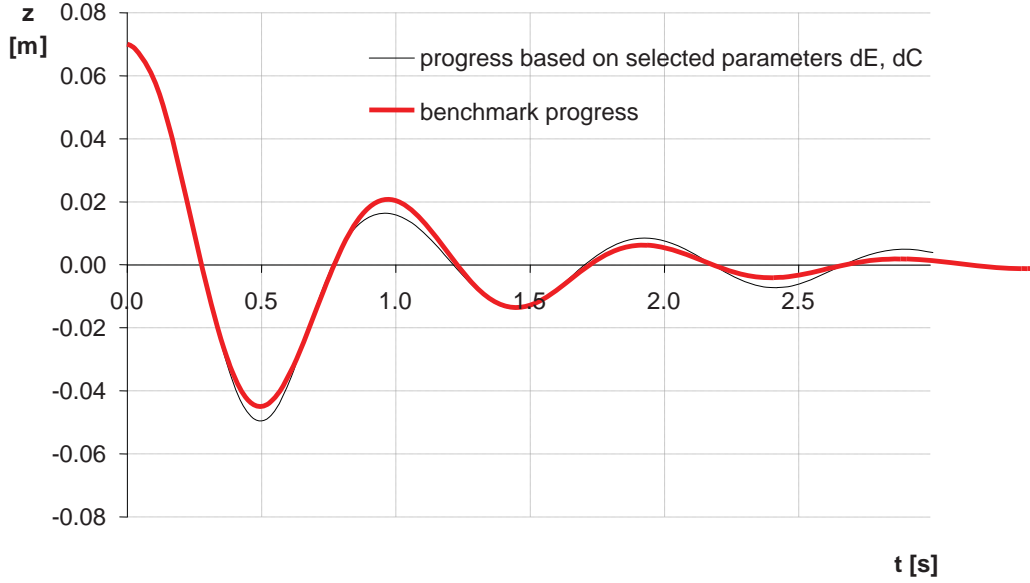

Fig. 10. Comparison of progresses of dependencies from valves diameters of damper orifice with benchmark element

### 5.3. Physical Model

Motion of individual blocks of the model is described by equations for ten degrees of freedom (six for vehicle body, one each for driving wheels trucks axles rotating around their own axles). Progress of the wheel friction torque  $M_{Hi}$  value of individual driving axles is the input quantity for the vehicle model. The model output is a set of physical quantities describing kinematics ( $a_p$ -braking delay,  $v_{Ki}$ -driving wheels rotational velocities) and its motion dynamics ( $Z_i$  – forward force of driving wheels on the ground).

### 5.4. Mathematical Model

Equations of the vehicle model motion were written in three rectangular, dextrorotary coordinate systems  $Oxyz$ ,  $O_1x_1y_1z_1$ ,  $O_2x_2y_2z_2$ . Basic equations deciding about the value of dynamic vertical forces, affecting the vehicle body, are presented below. equation of the vehicle body vertical motion (in the system of  $Oxyz$ ) mechanical suspension:

$$\ddot{z} = \frac{1}{m} \cdot (F_{z1} + F_{z2} + F_{z3} + F_{z4} - m \cdot g), \quad (66)$$

$$m \cdot \ddot{z} + k_{R1} \cdot (z - \vartheta \cdot a - z_1) + k_{R2} \cdot (z + \vartheta \cdot b - z_2) + c_{A1} \cdot (\dot{z} - \dot{\vartheta} \cdot a - \dot{z}_1) + c_{A2} \cdot (\dot{z} + \dot{\vartheta} \cdot b - \dot{z}_2) = 0, \quad (67)$$

hydropneumatic suspension:

$$m \cdot \ddot{z} + F_{HP1} + F_{HP2} = 0, \quad (68)$$

where:

$$F_{HP1} = f(z, \dot{z}, z_1, \dot{z}_1, \vartheta, \dot{\vartheta}), \quad (69)$$

$$F_{HP2} = f(z, \dot{z}, z_2, \dot{z}_2, \vartheta, \dot{\vartheta}), \quad (70)$$

- equation of the front-axle truck vertical motion (in the system of  $O_1x_1y_1z_1$ )  
mechanical suspension:

$$m_{11} \cdot \ddot{z}_1 - k_{R1} \cdot (z - \vartheta \cdot a - z_1) - c_{A1} \cdot (\dot{z} - \dot{\vartheta} \cdot a - \dot{z}_1) + k_{K1} \cdot z_1 + c_{K1} \cdot \dot{z}_1 = 0, \quad (71)$$

hydropneumatic suspension:

$$m_{11} \cdot \ddot{z}_1 - F_{HP1} + k_{K1} \cdot z_1 + c_{K1} \cdot \dot{z}_1 = 0, \quad (72)$$

- equation of the rear-axle truck vertical motion (in the system of  $O_2x_2y_2z_2$ );  
mechanical suspension:

$$m_{12} \cdot \ddot{z}_2 - k_{R2} \cdot (z + \vartheta \cdot b - z_2) - c_{A2} \cdot (\dot{z} + \dot{\vartheta} \cdot b - \dot{z}_2) + k_{K2} \cdot z_2 + c_{K2} \cdot \dot{z}_2 = 0, \quad (73)$$

hydropneumatic suspension:

$$m_{12} \cdot \ddot{z}_2 - F_{HP2} + k_{K2} \cdot z_2 + c_{K2} \cdot \dot{z}_2 = 0, \quad (74)$$

- equation of the vehicle body rotational motion (in the system of  $Oxyz$  against  $y$  axis):  
mechanical suspension:

$$I_Y \cdot \ddot{\vartheta} + k_{R1} \cdot a \cdot (z - \vartheta \cdot a - z_1) - k_{R2} \cdot b \cdot (z + \vartheta \cdot b - z_2) + c_{A1} \cdot a \cdot (\dot{z} - \dot{\vartheta} \cdot a - \dot{z}_1) - c_{A2} \cdot (\dot{z} + \dot{\vartheta} \cdot b - \dot{z}_2) + M_{H1} + M_{H2} + X_1 \cdot h_{W1} + X_2 \cdot h_{W2} = 0, \quad (75)$$

hydropneumatic suspension:

$$I_Y \cdot \ddot{\vartheta} + F_{HP1} \cdot a - F_{HP2} \cdot b + M_{H1} + M_{H2} + X_1 \cdot h_{W1} + X_2 \cdot h_{W2} = 0 \sim. \quad (76)$$

## 6. Conclusion

The hereto presented model of hydropneumatic suspension and the vehicle motion model are applied to assess dynamic capabilities and evaluate the real object motion safety. Results of the computations are presented in other publications of the authors.

## References

- [1] Duym, S., Stiens, R., Reybrouck, K., *Evaluation of Shock Absorber Models*, Vehicle System Dynamics, 27, pp. 109-137, 1997.
- [2] Elbeheiry, E. i inni, *Advanced Ground Suspension Systems – A Classified Bibliography*, Vehicle System Dynamics, 24, pp. 231-258, 1995.
- [3] Gardulski, J., Konieczny, Ł., *Wpływ obciążenia statycznego na tłumienie kolumny hydropneumatycznej*, Diagnostyka 4 (40), 2006.
- [4] Lanzendorfer, J., Szczepaniak, C., *Teoria ruchu samochodu*, WKiŁ, Warsaw 1980.
- [5] Łomako, D., Stańczyk, T., Grzyb, J., *Pneumatyczne układy hamulcowe w pojazdach samochodowych*, Politechnika Świętokrzyska, Kielce 2002.
- [6] Miatłuk, M., Kamiński, Z., *Układy hamulcowe pojazdów – obliczenia*, Wydawnictwo Politechniki Białostockiej, Białystok 2005.
- [7] Pilbeam, C., Sharp, R., *Performance Potential and Power Consumption of Slow-Active Suspension Systems with Preview*, Vehicle System Dynamics, 25, pp. 169-183, 1996.
- [8] Praca zbiorowa, CITROEN, *Les problemes de la suspension et la solution hydropneumatique*.

