

Konstanty GAWRYLCZYK, Mateusz KUGLER

POLITECHNIKA SZCZECIŃSKA, KATEDRA ELEKTROTECHNIKI TEORETYCZNEJ I INFORMATYKI

Structure recognition of conductive materials utilizing FE-algorithms of non-destructive eddy-current testing

D.Sc., Ph.D. Konstanty M. GAWRYLCZYK

Professor on the Chair of Theoretical Electrotechnics and Informatics of Szczecin University of Technology. His area of interest is the electromagnetic field theory and numerical methods used for analysis and synthesis of fields. Main applications lie in electromagnetic non destructive testing of materials and in development of semiconducting devices.



e-mail: kmg@ps.pl

Ph.D. Mateusz KUGLER

He works At the Chair of Theoretical Electrotechnics and Informatics of Szczecin University of Technology. His interest concentrates on numerical analysis and identification of electromagnetic fields applied to eddy-current testing.



e-mail: mkugler@ps.pl

Abstract

The paper deals with progress in electromagnetic methods used for structure evaluation of conducting materials. The term "electromagnetic methods" covers the following areas: magneto-inductive methods, magnetic leakage flux probe method, magnetometer principle and eddy-current methods. In 1948 the German visionary Friedrich Förster established his own company and developed highly sensitive measuring devices for magnetic fields at the Kaiser-Wilhelm-Institute. The methods and examples described in this paper relate only to eddy-current method, but the same idea may be applied for other methods, indeed. For the aim of inner structure recognition the sensitivity analysis with finite elements is proposed.

Keywords: Electromagnetism, Finite element analysis, Electromagnetic fields.

Rozpoznawanie struktury materiałów przewodzących przy wykorzystaniu algorytmów defektoskopii wiroprądowej opartych na MES

Streszczenie

Praca dotyczy postępu w elektromagnetycznych metodach badania struktur przewodzących. Od roku 1948, gdy niemiecki wizjoner Friedrich Förster rozpoczął badania w Instytucie Cesarza Wilhelma w badaniach tych nastąpił wielki rozwój. Metody i przykłady opisane w niniejszej pracy odnoszą się jedynie do wiroprądowych badań materiałów, jednak przedstawiona idea może być łatwo przeniesiona do innych metod elektromagnetycznych. Opiera się ona na analizie układu pomiarowego metodą elementów skończonych, a następnie na przeprowadzeniu zadania odwrotnego umożliwiającego identyfikację struktury wewnętrznej materiału. Efektywne przeprowadzenie takiego zadania wymaga dostarczenia informacji o gradiencie funkcji celu, do czego wykorzystywana jest analiza wrażliwościowa wielkości pola elektromagnetycznego. Metody tej analizy, dobrze poznane i opisane w teorii obwodów elektrycznych, są dopiero rozwijane dla pól elektromagnetycznych. Zadania odwrotne prowadzą zwykle do źle uwarunkowanych, nadokreślonych układów równań. Uzyskane rozwiązanie jest często wynikiem kompromisu możliwej do uzyskania rozdzielczości w stosunku do użytych danych pomiarowych obciążonych błędami. Zastosowanie regularyzacji pozwala uzyskać zbieżność algorytmu nawet w takich przypadkach.

Słowa kluczowe: elektromagnetyzm, metoda elementów skończonych, pola elektromagnetyczne.

1. Introduction

Eddy-current methods conventionally utilize the frequency band up to approx. 10 MHz with differential and absolute coils and which are used for testing for surface and inner flaws.

Semi-finished products, such as wires, bars and tubes, are tested for local flaws in the form of cracks and holes by encircling through-type coils. For example, valve spring wire is tested on a compact testing line with encircling, through-type coil and rotating scanning probes. The surface of semi-finished products or components is scanned with scanning probes. This allows maximum flaw resolution.

Eddy currents are alternating electrical currents, usually induced to any metallic section. The feeding frequency, and adequate penetration depth of eddy-currents, should be adapted to expected cracks and flaws. The flow pattern of currents is disturbed by cracks or other discontinuities in the metal. Eddy current flow patterns are either circumferential, using encircling or concentric coil configurations, or a tangential or loop pattern material affects the flow pattern which, in turn, affects its associated magnetic field. This change is detected by a suitable receiver coil. Search coils are usually wound in the form of a differential transformer, with the primary or excitation winding being fed from an oscillator. Two secondary windings observe the eddy current effects at displaced sections of the material under test, and automatically compare the cross-sections for any differences which may occur.

2. The numerical model of eddy-current coils arrangement

Numerical methods, those of finite elements in particular, offer some new tools for the analysis of eddy-current flaw detection systems. The problem of medium properties and its geometrical form has been solved in the case of two-dimensional and axially symmetric systems. The problem of analysis of three-dimensional systems remaining still unsolved, however. In addition to the difficulties connected with the uniqueness of solution or the way of determining the boundary conditions there is a serious obstacle of limited capacity of the memory and calculation speed of computers.

Since the geometry of the eddy current NDT system is complex, a truly three-dimensional analysis is required to obtain the eddy current distribution in the volume of the conducting structure. However, a fully three-dimensional analysis requires three vector components and a scalar gradient to represent the field fully. This procedure is complex and cumbersome. On the other hand, the axisymmetric computer code offers solution only to problems involving stationary coils and circumferential defects. In eddy current NDT the frequencies are usually low enough that the displacement current term in Maxwell's equations is negligible. It is profitable to introduce the magnetic vector potential A , defined as $B = \text{rot}A$, where B is the flux density vector. For three-dimensional considerations a very portable formulation bases on scalar magnetic potential φ : $H = \vec{T} \text{ grad } \varphi$. Utilizing property

$\text{div}\mathbf{H}=0$ one can obtain field equations $\nabla^2\varphi = \text{div}\mathbf{T}$, where $\text{rot}\mathbf{T} = \text{rot}\mathbf{H} = \mathbf{J}$.

The model of NDT-probe used for detection of material flaws shown in Fig. 1 was described in [1]. The probe consists of two shielded exciting coils and the secondary coil. In absence of the flaw the probe is balanced to the zero output signal. In NDT applications the signal from eddy current probes carries information concerning environment changes of the probe. The choice of suitable equivalent model for computer simulation of the sensor is probably the most important.

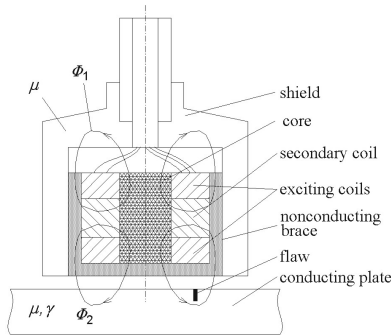

Fig. 1. The model of NDT-probe
Rys. 1. Model sondy wiroprowadzej

The finite element mesh modeling the probe from Fig. 1 consisted of 17028 tetrahedrons with 3584 nodal points. The mesh discretizing coils, core and shield is shown in Fig. 2 and Fig. 3.

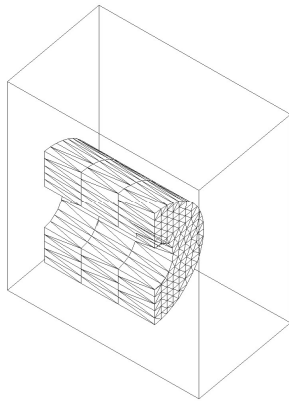

Fig. 2. The mesh inside of coils
Rys. 2. Siatka dyskretyzująca cewki

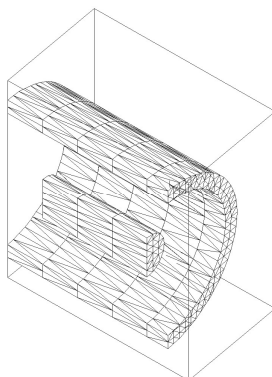

Fig. 3. The mesh in core and shield
Rys. 3. Siatka w rdzeniu i ekranie

Since the relationship between tangential component of field vectors \mathbf{E} and \mathbf{H} on the surface of conducting material is given by

$$\mathbf{1}_n \times \mathbf{E} = Z_s \mathbf{1}_n \times (\mathbf{1}_n \times \mathbf{H}), \quad (1)$$

where Z_s designates characteristic impedance of conductors, the problem formulation basing only on φ allows to analyze magnetic fields for such models, where the eddy-currents influence non-rotational field of φ only through appropriate boundary condition, so called impedance boundary condition. Using this simple model one can calculate resistance changes of absolute coil moving close to the defect (Fig. 4).

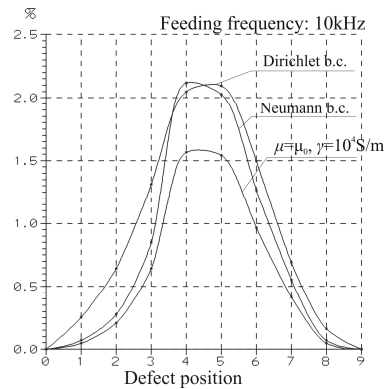

Fig. 4. Resistance changes of absolute coil for different coil positions
Rys. 4. Zmiany rezystancji cewki przesuwanej nad defektem

Some arrangements may be modeled using two-dimensional axisymmetric code for computer solution. One of the models with natural axial-symmetry is shown in Fig. 5. There are presented coils inspecting tube wall.

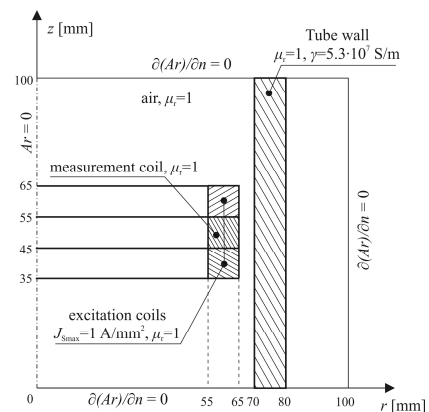
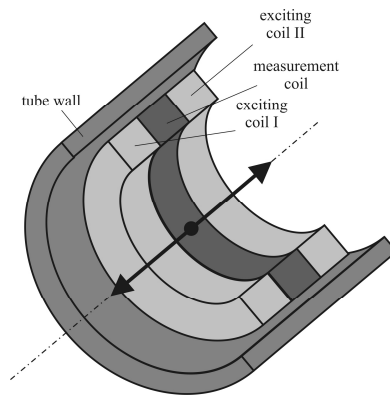

Fig. 5. Differential coils moving inside tube
Rys. 5. Cewki różnicowe przesuwane wewnątrz rury

Then, we should agree, that not only coils and tube, but also the modeled defect owns cylindrical symmetry. This may be treated roughly as the case of welds inspection.

3. Inverse problem

Inverse problem consists typically in estimation of material parameters, inaccessible in direct way, basing on indirect measurement of other quantities. For example, distortion of conductivity inside tube wall yields measurements of magnetic field distribution over the surface. This measurements are only indirect related to the conductivity distribution that is to be determined. The estimation process is often ill-posed due to noise in the input data. To obtain at least approximate solution in the case of ill-posed problems regularization techniques have been developed.

For the conductivity estimation we use iterative algorithm basing on nonlinear optimization technique of Gauss-Newton. The dependence between conductivity γ inside the finite elements and the field distribution over the conducting plate represented by the magnetic vector potential A , is given by the following equation:

$$\begin{bmatrix} \Delta A_1 \\ \Delta A_2 \\ \Delta A_3 \\ \dots \\ \Delta A_j \end{bmatrix} = \begin{bmatrix} S_{11} & S_{12} & S_{13} & \dots & S_{1i} \\ S_{21} & S_{22} & S_{23} & \dots & S_{2i} \\ S_{31} & S_{32} & S_{33} & \dots & S_{3i} \\ \dots & \dots & \dots & \dots & \dots \\ S_{j1} & S_{j2} & S_{j3} & \dots & S_{ji} \end{bmatrix} \cdot \begin{bmatrix} \Delta \gamma_1 \\ \Delta \gamma_2 \\ \Delta \gamma_3 \\ \dots \\ \Delta \gamma_i \end{bmatrix} \quad (2)$$

where: j – number of measurements, i – number of elements in the search region, $[S]$ – sensitivity matrix. The field measurements can be carried out either for harmonic feeding current of frequency ω , or for impulse excitation for discrete time steps. For example, when identifying an inner crack, the multi-frequency method can be used. In this case, the sensitivity values S_{ji} are evaluated in the frequency domain. If the eddy-currents are induced by the coil driven by non-harmonic current impulse, the time-domain evaluation is necessary.

The objective function in the conductivity recognition problems is nonlinear with respect to the material conductivity. So the iterative optimization procedure using sensitivity information has to be adopted. After each iteration, the results are compared with that of the measurements and new values ΔA_j for Eq. (1) are obtained. The terms of sensitivity matrix $[S]$ are obtained using adjoint model. This method requires an access to the source code of finite element package. However, the calculations with standard FE-code are also possible, but not so effective.

4. Evaluation of sensitivity matrix

Similar, as in the circuit theory, the sensitivity may be obtained either by direct differentiation of stiffness matrix of finite elements, or by analysis of adjoint model. Both methods are numerically effective, but the Tellegen's adjoint model method delivers directly gradients of goal function. In following we describe evaluation of sensitivity in time-domain using Tellegen's method.

Discretizing non-homogeneous diffusion equation for transient magnetic field analysis we chose the generalized time stepping scheme *theta* described in [2]. The time function is approximated with linear shape functions, continuous for every time element $t_{n-1} \leq t \leq t_n$ (Fig. 6).

In the case of first order elements the following two level scheme can be shown:

$$\left[\theta [K] + \frac{1}{\Delta t} [M] \right] \{A_n\} = \left\{ \left[\frac{1}{\Delta t} [M] - (1-\theta) [K] \right] \{A_{n-1}\} + (1-\theta) \{i_{on-1}\} + \theta \{i_{on}\} \right\} \quad (3)$$

where $[K]$ is the stiffness and $[M]$ the mass matrix of finite elements, $\{A_n\}$ is the vector of the desired node values, and $\{i_{on}\}$ is the discretized excitation (nodal currents) for time steps $n \cdot \Delta t$, with $n = 1, 2, \dots, N$. Depending from assumed value of parameter θ from the range $\langle 0, 1 \rangle$ the following stepping schemes may occur: for $\theta = 0$ the equation (1) becomes forward Euler scheme, for $\theta = 1/2$ the Crank-Nicholson scheme, for $\theta = 2/3$ Galerkin scheme, and in the case of $\theta = 1$ we obtain the backward Euler scheme. The unconditional stability is guaranteed for θ from the range of $\langle 1/2, 1 \rangle$.

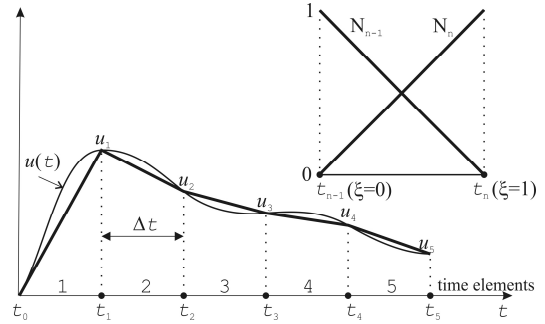

Fig. 6. Finite elements in time-domain

Rys. 6. Elementy skończone w dziedzinie czasu

The Tellegen's sensitivity equation may be derived from Lorenz reciprocity theorem. Two systems have to be analyzed, the adjoint one has the same topology and material parameters, and differs from original only with the excitation. Both are analyzed on the same area Ω , but for different times t and τ . The time τ is reverse to t , it means $\tau = \xi - t$, where ξ denotes the time, while the sensitivity is evaluated.

For the tasks of electric field sensitivity versus electric conductivity γ , the sensitivity equation simplifies to:

$$\int_0^\xi \int_\Omega J_o^+(\tau) \cdot \delta E(t) d\Omega dt = \int_0^\xi \int_\Omega E^+(\tau) \cdot \delta \gamma \cdot E(t) d\Omega dt \quad (4)$$

where $E = -\partial A / \partial t$ is the only non-zero component of electric intensity vector, perpendicular to the plane of analysis, A – non-zero component of magnetic vector potential, and J_o excitation current density. The variables denotes with $(\cdot)^+$ relate to adjoint system, other one to original. The sensitivity equation shows the changes in δE caused by conductivity variation $\delta \gamma$.

The adjoint model allows to calculate the changes of field value for assumed area on the whole. This area depends on the excitation of adjoint model.

In the case of transient analysis, also the shape of excitation has to be chosen. From the sensitivity analysis point of view, the right choice of adjoint model excitation leads to simplification of the left hand side eqn. (4). We propose an application either unit step impulse:

$$i_o^+(\tau) = \Gamma(\tau) = \begin{cases} 0 & \text{for } \tau \leq 0 \\ 1 & \text{for } \tau > 0 \end{cases}, \quad (5)$$

or the Dirac's impulse:

$$i_o^+(\tau) = \delta(\tau) \quad \text{where} \quad \begin{cases} \delta(\tau) = 0 & \text{for } \tau \neq 0 \\ \int_{-\infty}^{\infty} \delta(\tau) d\tau = 1 \end{cases}. \quad (6)$$

The assumed excitations are not realizable physically, they are acting only in virtual, adjoint system.

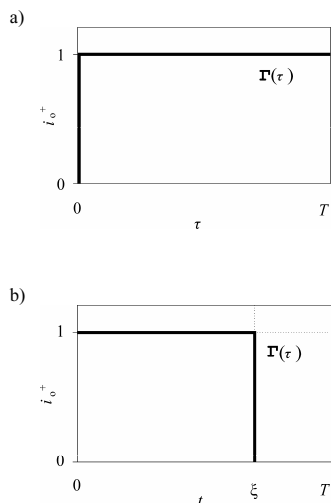

Fig. 7. Unit step impulse as adjoint model excitation: a) in the backward time τ domain, b) in the current time t domain

Rys. 7. Skok jednostkowy jako kształt pobudzenia modelu dołączonego: a) w czasie przeciwbieżnym τ , b) w czasie oryginalnym t

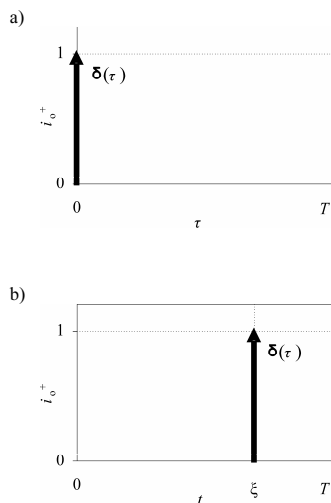

Fig. 8. Dirac's impulse as adjoint model excitation: a) in the backward time τ domain, b) in the current time t domain

Rys. 8. Impuls Diraca jako kształt pobudzenia modelu dołączonego: a) w czasie przeciwbieżnym τ , b) w czasie oryginalnym t

5. Examples of conductivity estimation

The examples below (Figs. 9, 10) show conductivity distribution inside tube wall estimated after 5, 10 and 20 iterations. Used algorithm basing on Gauss-Newton method was described in [3]. The input data for assumed crack shape were obtained by simulation using the mesh containing 189 696 finite elements, however, for solution of inverse problem the coarse finite element mesh with 128 700 was implemented. The different discretization error of both meshes gives the similar effect, as noise by real measurement.

6. Conclusions

The success of numerical evaluation of conductivity distribution depends mainly on the exact measurement of the magnetic flux. The error of sensitivity evaluation has a secondary meaning and influences only the manner in which the result is obtained. In the examples shown above, instead of the measurements, the models with cracks were analyzed by FEM providing data for further iterative process. Then, the cracks were removed, and the algorithm tried to reconstruct the magnetic field basing on sensitivity values of

induced coil voltage. If the real data containing measurement errors will be used, the results could be worse.

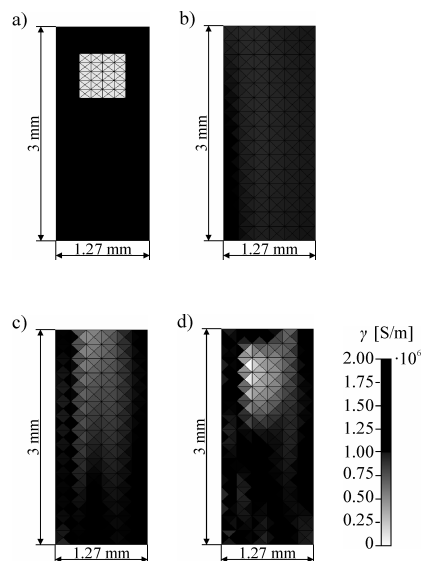

Fig. 9. Conductivity distribution: a) assumed, b) recognized after 5 iterations, c) after 10 iterations, d) after 20 iterations

Rys. 9. Rozkład konduktywności: a) modelowy, b) rozpoznany po 5 iteracjach, c) po 10 iteracjach, d) po 20 iteracjach

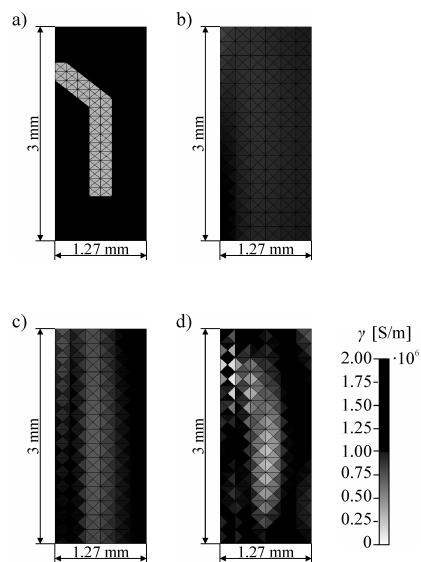

Fig. 10. Conductivity distribution: a) assumed, b) recognized after 5 iterations, c) after 10 iterations, d) after 20 iterations

Rys. 10. Rozkład konduktywności: a) modelowy, b) rozpoznany po 5 iteracjach, c) po 10 iteracjach, d) po 20 iteracjach

7. References

- [1] K.M. Gawrylczyk: Sensitivity evaluation methods of electromagnetic quantities with FE-analysis. COMPEL, Vol.17, No 1/2/3,1998, pp.78-84.
- [2] O.C. Zienkiewicz, K. Morgan: Finite Elements and Approximation Method. John Willey & Sons, New York 1983.
- [3] K.M. Gawrylczyk, M. Kugler: Time Domain Sensitivity Analysis of electromagnetic Quantities Utilising FEM for the identification of material conductivity distributions, COMPEL, vol.25, No.3, 2006, pp.589-595.