

A. DZIADOŃ*, R. MOLA*, L. BŁAŻ**

FORMATION OF LAYERED Mg/EUTECTIC COMPOSITE USING DIFFUSIONAL PROCESSES AT THE Mg-Al INTERFACE

OTRZYMYWANIE KOMPOZYTU WARSTWOWEGO Mg-EUTEKTYKA NA DRODZE PROCESÓW DYFUZYJNYCH ZACHODZĄCYCH NA GRANICY Mg-Al

A processing technique has been developed to produce a layered magnesium-intermetallic compound light composite from elemental magnesium and aluminium sheets. Structural examination and measurements of transition layer grown at the magnesium-aluminium interface at high annealing temperature were performed. It was found using Mg/Al diffusion couple that solid state diffusion results in development of Al_3Mg_2 and $\text{Mg}_{17}\text{Al}_{12}$ intermetallic compounds, which are separated into two sublayers. The rate of the layer growth substantially increases with the appearance of the liquid phase at the Mg-Al interface. The microstructure resulted from the partial solidification contains an eutectic composed of $\text{Mg}_{17}\text{Al}_{12}$ intermetallic compound and solid solution aluminium in magnesium. The structural processes, which transform the magnesium-aluminium interface, can be applied for fabrication of layered magnesium-eutectic composites. Alternately stacked magnesium and aluminium sheets, formed into a packet, were heated until aluminium was exhausted throughout the course of the Mg-Al reaction with the liquid phase contribution. As a result, the composite containing residual magnesium and layers of eutectic mixture ($\text{Mg}_{17}\text{Al}_{12}$ and solid solution of aluminium in magnesium) was obtained. Rapid solidification resulted in fine-grained eutectic microstructure development. Using the presented method, composites with required thickness ratio of magnesium and the eutectic layers can be obtained by choosing appropriate thickness ratio of starting magnesium and aluminium sheets.

Keywords: metal-matrix composites, layered composite, intermetallics

Opracowano metodę otrzymywania kompozytu zbudowanego z warstw magnezu i warstw zawierających związek między-metaliczny, wykorzystując jako substraty blachę magnezu i blachę aluminium. Stosując złącze dyfuzyjne Mg/Al przeprowadzono badania zmian strukturalnych zachodzących pod wpływem temperatury na granicy międzyfazowej magnez-aluminium oraz badania wzrostu warstwy produktów reakcji. Stwierdzono, że warstwa ta, utworzona w wyniku zachodzących w stanie stałym przemian dyfuzyjnych, składa się z dwu podwarstw o strukturze związków międzymetalicznych: Al_3Mg_2 i $\text{Mg}_{17}\text{Al}_{12}$. Szybkość wzrostu warstwy zwiększa się znacznie, gdy na granicy Mg-Al pojawia się faza ciekła. Mikrostruktura utworzona podczas krzepnięcia zawiera głównie eutektykę, składającą się ze związku międzymetalicznego $\text{Mg}_{17}\text{Al}_{12}$ i roztworu stałego aluminium w magnezie. Zjawiska zachodzące na granicy magnez-aluminium zostały wykorzystane do formowania kompozytu warstwowego magnez-eutektyka. Arkusze blachy magnezu i blachy aluminium ułożone naprzemiennie w pakiet wygrzewa się do momentu wyczerpania się aluminium w reakcji z magnezem zachodzącej z udziałem fazy ciekłej. W wyniku powstaje kompozyt składający się z warstw pozostałego magnezu i warstw eutektyki zbudowanej z $\text{Mg}_{17}\text{Al}_{12}$ i roztworu stałego aluminium w magnezie. Gwałtowne krzepnięcie pozwala uzyskać eutektykę o drobnoziarnistej mikrostrukturze. Przez dobór stosunku grubości wyjściowych arkuszy blachy magnezu i blachy aluminium można wykonać kompozyty o dowolnym stosunku grubości magnezu do grubości warstw o strukturze eutektyki.

1. Introduction

In recent years, magnesium and its alloys have been a subject of great interest mainly because magnesium is the lightest construction metal. The weight reduction of transportation equipment is a very important factor, especially within the automobile industry [1]. However, the low elastic modulus of magnesium and its alloys

has resulted in limited application of these materials. Higher elastic modulus can be obtained by the addition of the reinforcing phases to the magnesium matrix. It was reported that using numerous methods, the particulate-reinforced [2-8] and fibre reinforced [9-11] magnesium composites can be fabricated. Improvement of the material properties depend on the morphology and volume fraction of reinforcement and its shape. It is ex-

* KIELCE UNIVERSITY OF TECHNOLOGY, DEPARTMENT OF METALS SCIENCE AND MATERIALS TECHNOLOGIES, 25-314 KIELCE, AL. TYSIĄCLECIA PAŃSTWA POLSKIEGO 7, POLAND

** AGH – UNIVERSITY OF SCIENCE AND TECHNOLOGY, DEPARTMENT OF STRUCTURE AND MECHANICS OF SOLIDS, 30-059 KRAKÓW, AL. MICKIEWICZA 30, POLAND

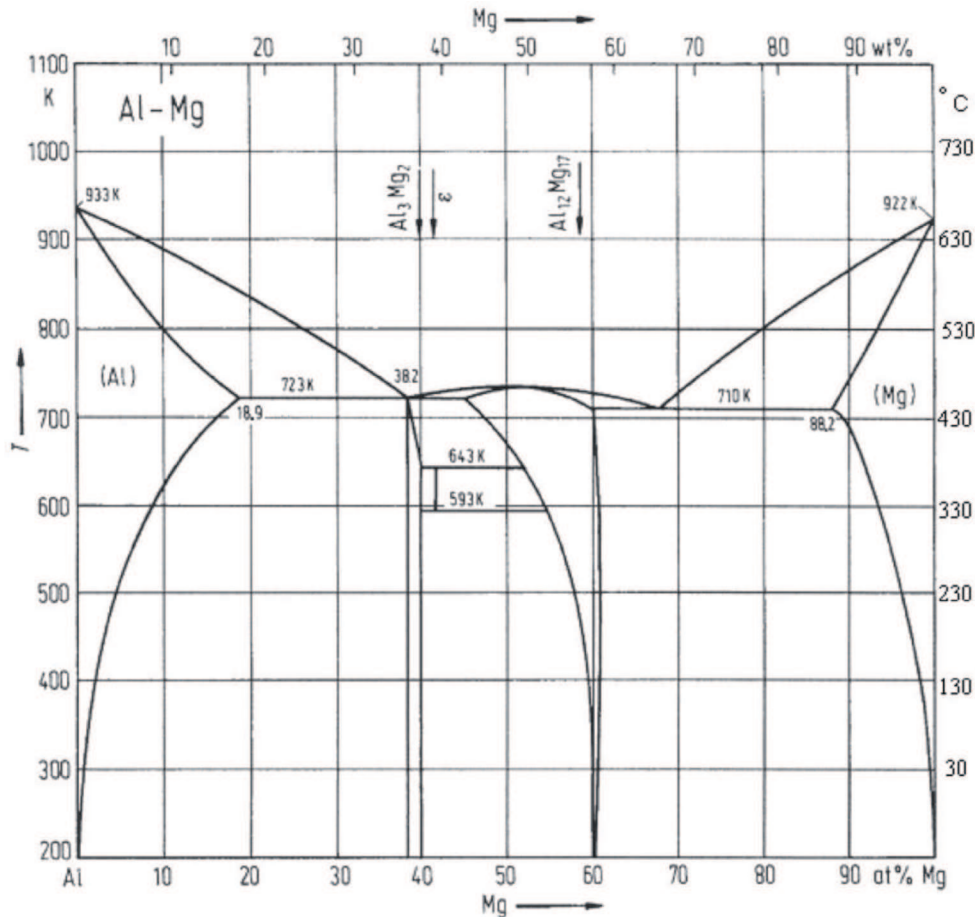

Fig. 1. Al-Mg phase diagram [19]

pected that substantially higher stiffness and mechanical properties can be received for layered composites and this idea provides the motivation for the present work. Therefore, experimental work was focused on choosing the best conditions for the manufacture of a composite with layers of magnesium metallurgical bonded with alternately located hard layers containing intermetallic phases.

Intermetallic phases can be synthesised by diffusion bonding of different metals at high enough temperature. Rawers and co-workers [12-14] demonstrated that received intermetallics can be formed into layers located between layers of pure metals. The foils of two different metals, stacked alternately into a packet, were heated until one of the metals is fully consumed in the course of high-temperature reactions. Using this method Ni-intermetallics, Fe-intermetallics, Ti-intermetallics [12-14], Ti-3Al-2.5V-intermetallics [15] and Cu-intermetallics [16-18] layered composites have been produced. In the present work, aluminium foil was chosen to synthesize intermetallic phases in layered magnesium-based composite because of its lightweight and common use of aluminium as an alloying element

of the magnesium alloys. According to Al-Mg binary phase diagram, presented in Fig. 1, in the Al-Mg system the $Mg_{17}Al_{12}$ and Al_3Mg_2 intermetallic compounds are formed [19]. The ϵ -phase is formed at high temperature but is not observed at room temperature. At the magnesium side, the eutectic containing $Mg_{17}Al_{12}$ and a solid solution of aluminium in magnesium are reported.

2. Experimental procedure

The materials used in the experiment were 99.9% purity magnesium and aluminium sheets. Specimens 30 mm×15 mm in size were cut from 3.0 mm thick magnesium and 0.8 mm thick aluminium sheets. After mechanical polishing of the joining surfaces, the Mg-Al samples were placed in a vacuum furnace and held at 430°C (just below the eutectic temperature of 437°C) for a few minutes. A pressure of 5 MPa was used to ensure good contact between metals. Due to solid state diffusion, the specimens were joined into a Mg-Al couple. The Mg-Al couples were then used to study the structural transformation that take place, with the contribution of liquid phase, at the Mg-Al interface. To determine the rate of

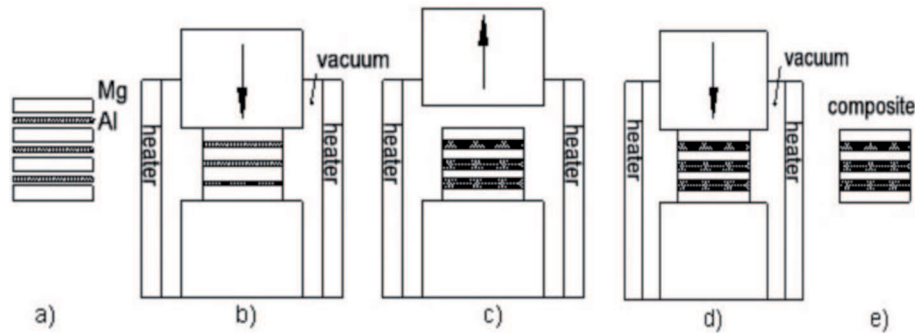

Fig. 2. Schematic presentation of the process used for the composite manufacture:

- Mg and Al sheets are stocked into a packet,
- diffusion bonding of the sheets at 430°C,
- processing with the liquid phase contribution at 445°C,
- final consolidation of the composite under pressure,
- magnesium-eutectic layered composite

intermetallic layer growth at the Mg-Al interface and an analysis of structural components, the Mg-Al couples were annealed at 445°C in an open air furnace (just over the eutectic temperature of 437°C) for varying periods of time. Structural observations were performed using a Neophot 2 optical microscope, a scanning electron microscope (JMS 5400) equipped with ISIS 300 Oxford Instruments system for energy dispersive X-rays analysis (EDX), JEM 2010 analytical transmission electron microscope equipped with scanning transmission electron microscopy device (STEM) and Oxford PENTAFET – EDX system. Measurements of the layer thickness at the Mg-Al interface with respect to holding time was performed by means of a commonly used optical microscopy technique.

On the basis of mentioned above investigations, a procedure for the composite formation was elaborated. Scheme of the process used for the composite formation was shown in Fig 2. Magnesium and aluminium sheets were stacked alternately into a packet. For diffusion bonding of the Mg and Al sheets to occur, the packet was held at 430°C for 10 minutes in the vacuum furnace under pressure of 5 MPa. The load was then removed and the packet was annealed at 445°C for 60 minutes. In order to test the effects of undercooling on the dispersion of solidifying phases, the packets were furnace cooled, air cooled, water quenched and cooled in -50°C methyl alcohol bath. Finally, the samples were compressed at 400°C using a pressure of 5 MPa for better consolidation of the composite. Microstructure observations and micro-hardness tests within the layers of composite were performed. Vickers micro-hardness (HV0.1) was measured using a Hanemann micro-hardness tester mounted on the Neophot 2 microscope.

3. Results and discussion

Solid state diffusion produces two distinguishable layers between Mg and Al metals. The microstructure of the Mg-Al couple that was annealed at 430°C for 20 minutes, was shown in Fig. 3. Following chemical composition of the layer marked A, formed on the aluminium side, was received using SEM and EDX analysis: 41.0 at.% Mg, and 59.0 at.% Al. The result indicates, according to Al-Mg diagram (Fig. 1.), an Al_3Mg_2 intermetallic compound development. X-ray microprobe analysis of the narrow layer (marked B) in the neighbourhood of magnesium revealed chemical composition of 58.9 at.% Mg, and 41.1 at.% Al, which suggests that $\text{Mg}_{17}\text{Al}_{12}$ compound was formed.

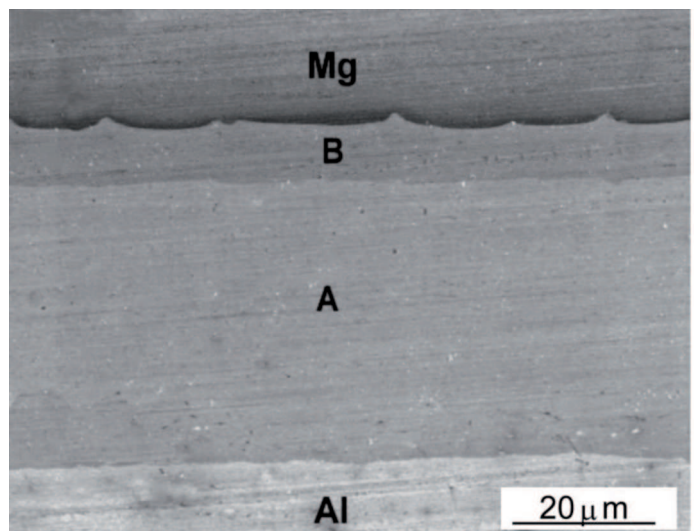

Fig. 3. Microstructure of the Mg-Al interface. The specimen was annealed at 430°C for 20 minutes

If Mg-Al samples are held at 445°C, the liquid phase appears at the Mg-Al interface. Transition layer formed after 20 minutes between magnesium and aluminium layers is presented in Fig. 4. The dendritic structure of the layer clearly indicates that the reaction at the Mg-Al interface proceeds with the liquid phase contribution.

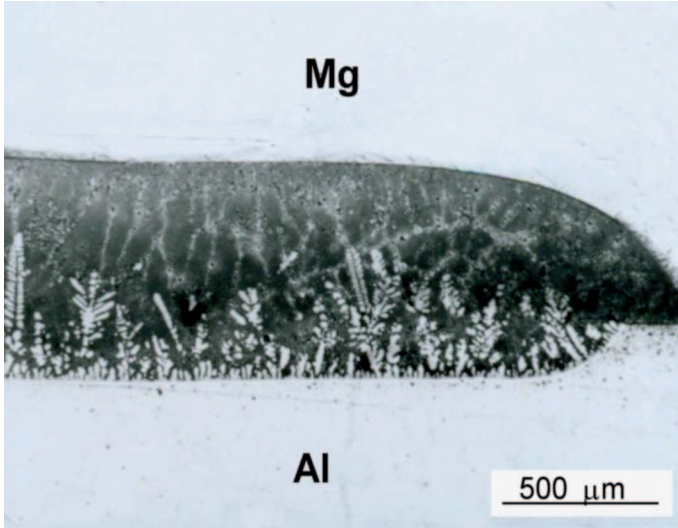

Fig. 4. Microstructure formed between Mg and Al sheets. The specimen was annealed at 445°C for 20 minutes to form a fine magnesium-aluminium liquid layer. The specimen was furnace cooled to room temperature

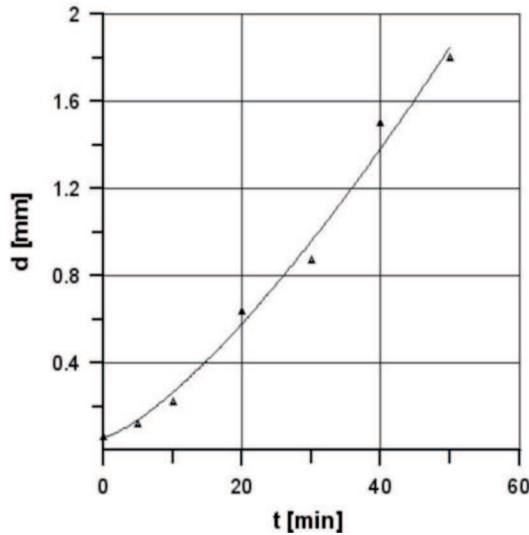
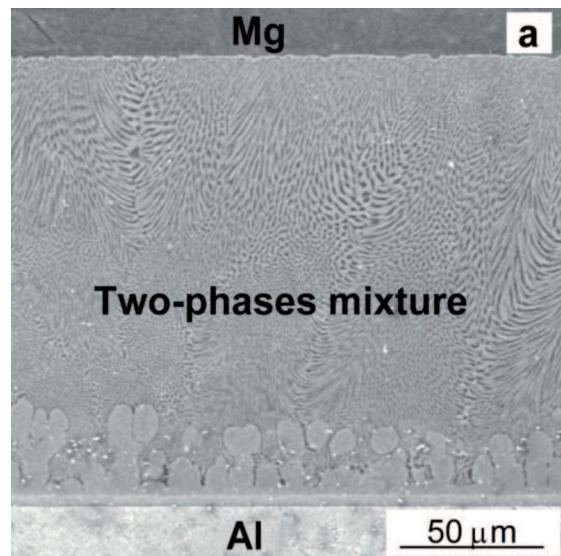

Fig. 5. Effect of annealing time on the thickness of the reaction zone at 445°C

The thickness of the layer was measured as a function of holding time. Results of the measurements are shown in Fig. 5. The layer thickness vs. annealing time relation was found: $d = 0.0093 \cdot t^{1.34}$ (d – thickness of the layer in mm, t – time in min.). It was also found that the rate of the layer growth substantially exceeds a parabolic growth reported in literature [20-23] for in-

termetallic phases received due to interdiffusion of the components in the solid state. Microstructure of the layer that was formed at the front of the Mg-Al reaction was shown in Fig. 6 for the Mg-Al couple held at 445°C for 10 minutes. Details of the microstructure as observed on the aluminium side and on the magnesium side are given in Fig. 6b and Fig. 6c, respectively. The dominant part of the microstructure is the two-phase mixture (Fig. 6a). On the aluminium side a narrow sublayer adjacent to the aluminium-substrate (A-region in Fig. 6b) and dendrites (B) can be distinguished. In the edge of magnesium layer, a thin and homogeneous zone (marked C in Fig. 6c) was observed. Analysis of the microstructure was based on the Al-Mg binary phase diagram presented in Fig. 1 and on the results of the X-ray microanalysis. The chemical composition of the layer marked A is as follows: 60.7 at.% Al, and 39.3 at.% Mg. Received stoichiometry of elements suggests the presence of an Al_3Mg_2 intermetallic compound. Chemical composition of dendrites (marked B), 63.0 at.% Mg and 37.0 at.% Al, was found to be close to the $Mg_{17}Al_{12}$ intermetallic compound stoichiometry. The chemical composition of the zone marked C was 87.6 at.% Mg and 12.4 at.% Al, which can be considered as a layer of aluminium solid solution enriched with magnesium. During mapping of aluminium and magnesium in the area of the two-phase structure, grey and white structural components of the eutectic revealed enhanced Mg and Al X-ray radiation, respectively. On the basis of the Al-Mg diagram analysis and taking into account that magnesium was the prevailing element over aluminium, it can be concluded that the heterogeneous structure is the eutectic composed of the $Mg_{17}Al_{12}$ intermetallic compound and a solid solution of aluminium in magnesium.



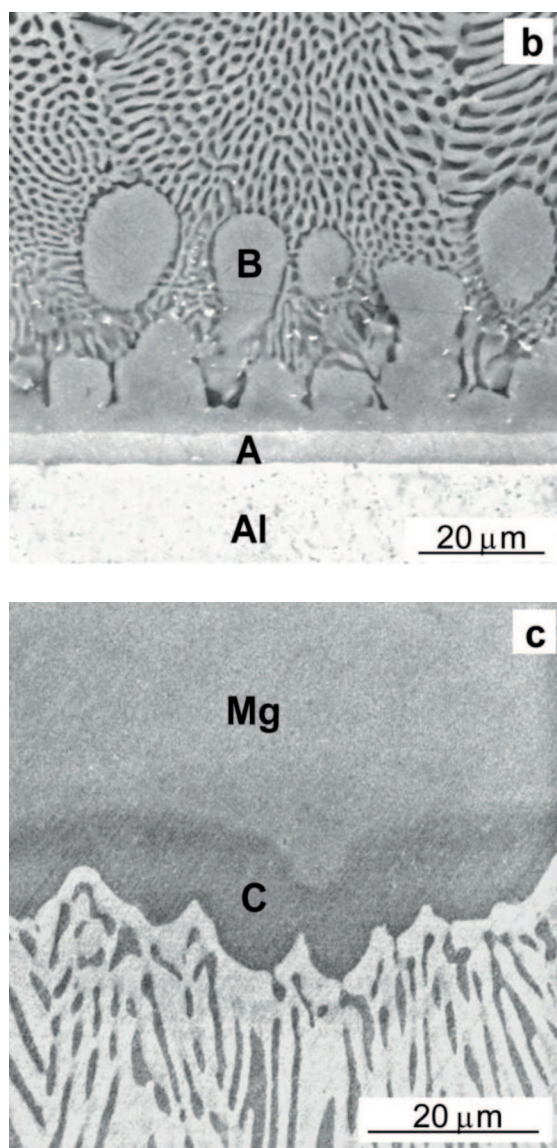

Fig. 6. Microstructure formed between Mg and Al sheets after solidification of the melting zone (a), microstructure in the neighbourhood of aluminium layer (b), microstructure in the neighbourhood of magnesium layer (c). Mg-Al couple was annealed at 445°C for 10 minutes and surface cooled

The results mentioned above clearly show that the structure resulting from the solidification of a liquid layer contains phases that are all enriched in magnesium. Therefore, the front of the reaction zone at Al/Mg couple have evidently migrate into the magnesium sheet, as shown in Fig. 4. In spite of complete Al dissolution due to reaction with the liquid phase contribution, more volume of Mg than Al is consumed.

Structural analysis of the transformation process, with the liquid phase contribution at the Mg-Al interface that is described above, offers a simple method for the composite manufacture. For the composite formation to occur, the reaction between the magnesium and aluminium sheets must be prolonged until all the aluminium is fully exhausted and transformed with part of the

magnesium *via* liquid phase into the composite layers. A macro-structure of the sample sectioned perpendicularly to the composite layers, observed at low magnification, is shown in Fig. 7a. Layers of residual magnesium are stacked between layers containing products of the Mg-Al reaction. The transition region from the magnesium layer to the layer of the two-phase structure is characterized by the zone of solid solution of aluminium in magnesium, which is denoted α in Fig. 7b. Transmission electron microscopy analysis has confirmed the two-phase structure of the composite layers containing the eutectic composed of $Mg_{17}Al_{12}$ intermetallic compound and a solid solution of aluminium in magnesium. Structure of the eutectic area, observed by TEM,

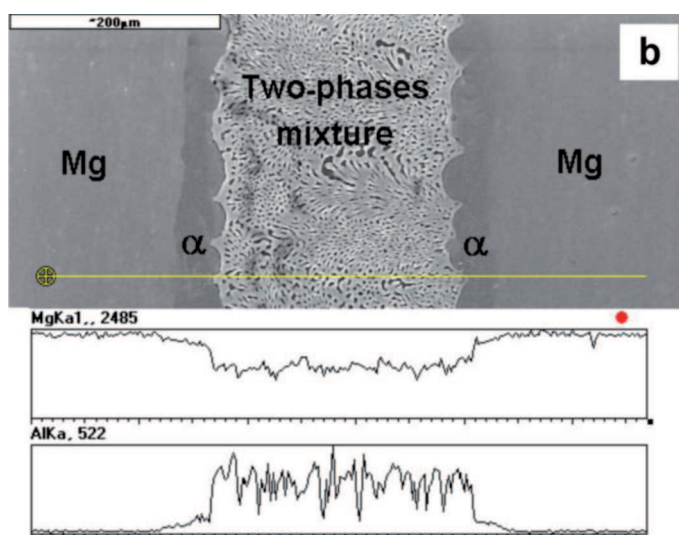
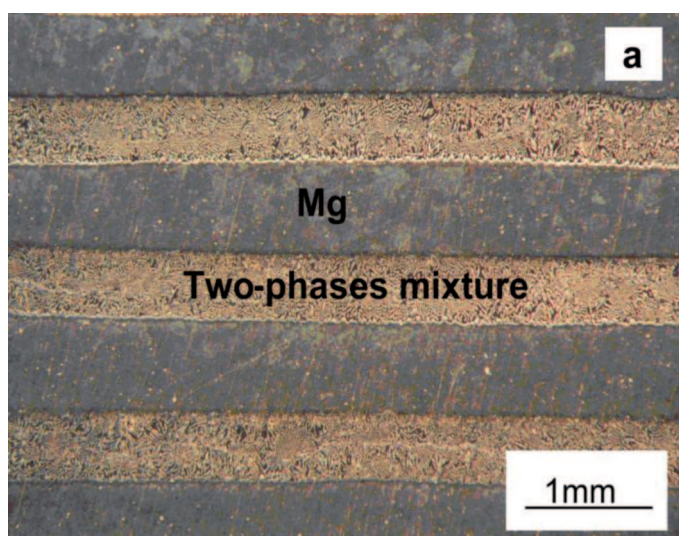

Fig. 7. Microstructure of the Mg-intermetallic composite (a) and concentration of Mg and Al profile across the composite layers (b)

is shown in Fig. 8A. The selected area diffraction pattern (Fig. 8b) taken from a dark grain, denoted A in Fig. 8a, correspond to $Mg_{17}Al_{12}$ phase. Selected area diffraction pattern taken from the grain B, observed on the oppo-

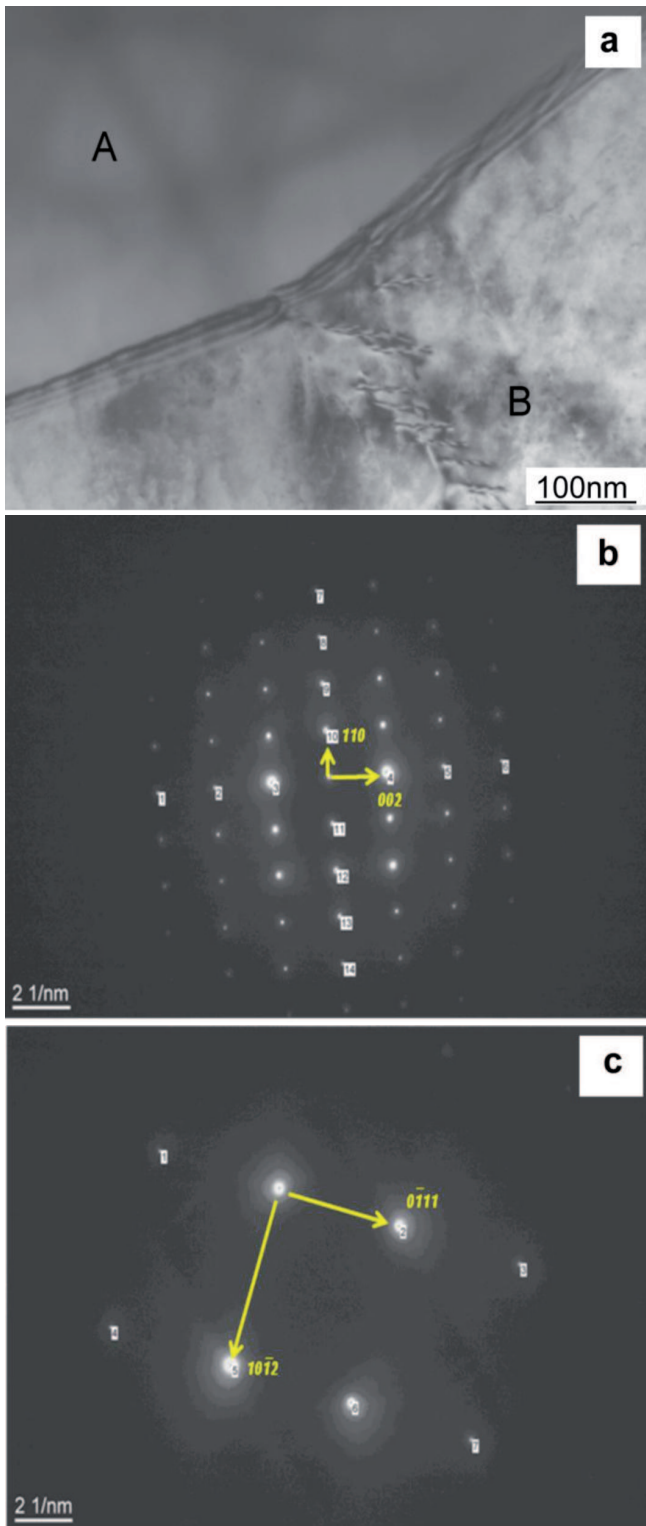
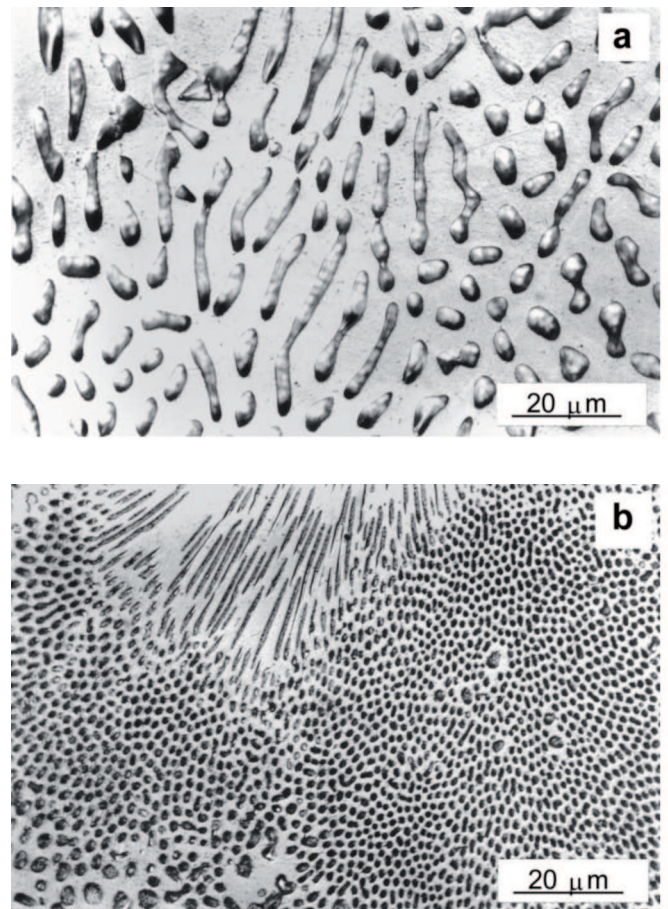

Fig. 8. Transmission electron micrograph of eutectic area (a). Selected diffraction patterns received from a grain marked (A) and a grain marked (B) are presented in figures (b) and (c) respectively

site side of the interphase boundary, corresponds to a hexagonal close packed structure (Fig. 8c). Related energy dispersive X-ray microanalysis revealed chemical composition of 7.8 at.% Al, and 92.2 at.% Mg. These results confirm a previous statement on a solid solution

of aluminium in magnesium development. Dislocations observed in the solid solution zone are extended from the interphase boundary, and they likely result from the internal stresses raised from different contraction of the crystals during solidification and their different thermal shrinkage during following cooling of the material.

Structural observations described above were performed for the sample, which was slowly cooled after completion of the high temperature reactions. This leads to large dimensions of the structure components, which solidify as the eutectic mixture. It is commonly accepted that the morphology of the eutectic constituents affects mechanical properties of the material. The effect of cooling conditions on the grain refining and received morphology of the eutectic components is shown in Fig. 9. A wide spectrum of microstructures can be obtained and this aspect must be taken into account in the composite processing. As the increase of solidification rate results in refined microstructure, a direct relationship between cooling conditions and the hardness of the eutectic layer is observed. The results of micro-hardness measurements are listed in Table 1. Rapid water quenching of the sample result in 37% hardness increase for the eutectic layer with respect to slowly cooled one. In the quenched samples, cracks produced by quenching stresses were not observed.



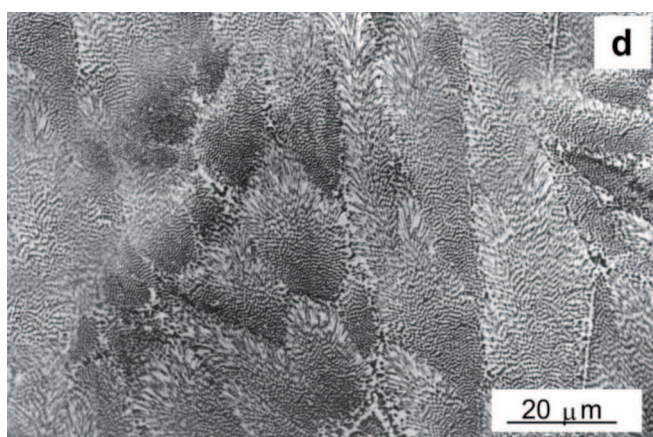
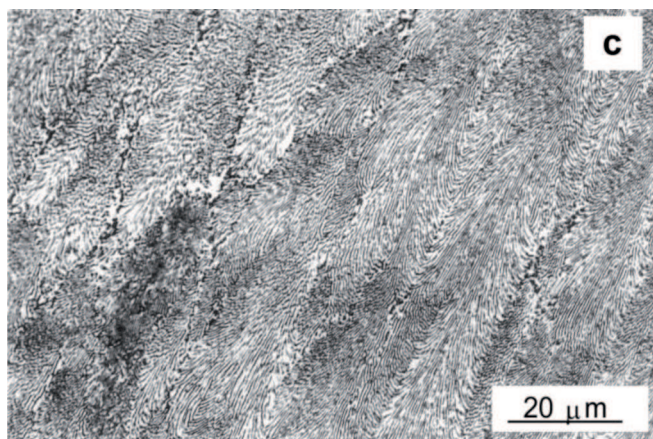

Fig. 9. Morphology of the eutectic containing $Mg_{17}Al_{12}$ and solid solution of aluminium in magnesium, which was formed at following cooling procedure: furnace cooling (a), air cooling (b), water quenching (c), quenching in methyl alcohol bath preliminary cooled to $-50^{\circ}C$ (d)

TABLE 1

Results of micro-hardness measurements for eutectic layers

Cooling conditions	Micro-hardness HV0.1
Furnace cooling	187
Air cooling	213
Water quenching	256
Quenching in methyl alcohol cooled to $-50^{\circ}C$	236

It should be also added that a spectrum of Al-Mg composites with varied ratio of Mg layers to layers containing eutectic can be produced by an adequate matching of the starting Mg and Al sheets thickness ratio.

4. Conclusions

1. Solid state diffusion at high enough annealing temperature was found to result in a growth of two separate layers between magnesium and aluminium sheets. The layer's structure was identified as $Mg_{17}Al_{12}$ and Al_3Mg_2 intermetallic compounds.

2. Structural transformation processes at the Mg-Al interface became substantially faster when a liquid phase at the Mg-Al couple appears. After solidification, a microstructure containing dendrites of $Mg_{17}Al_{12}$ and a two-phase eutectic layer is observed. As the phases resulting from solidification are rich in magnesium, migration of the reaction zone is more efficient into magnesium than into aluminium.
3. To form a composite, the reaction between magnesium and aluminium sheets (stacked alternately into a packet) must be prolonged until all the aluminium is exhausted. The composite consists of well-bonded layers of remaining magnesium and layers of eutectic containing $Mg_{17}Al_{12}$ intermetallic compound and solid solution of aluminium in magnesium.
4. Fine-grained eutectic layers can be formed using rapid solidification after high temperature treatment of Mg-Al stacked sheets. The hardness value received for the fine-grained eutectic layer was found to increase 37% with respect to the coarse-grained eutectic formed at slowly-cooled composite.

Acknowledgements

This work has been funded by the Polish Ministry of Science and Higher Education under the contract number N50708932/2436.

REFERENCES

- [1] H. Friedrich, S. Schumann, Research for a "new age of magnesium" in the automotive industry. *J. Mater. Process. Tech.* **117**, 276-281 (2001).
- [2] A. Bochenek, K.N. Braszczyńska, Structural analysis of the MgAl5 matrix cast composites containing SiC particles. *Mat. Sci. Eng. A* **290**, 122-127 (2000).
- [3] R.A. Saravanan, M.K. Surappa, Fabrication and characterization of pure magnesium-30 vol.%SiC_p particle composite. *Mat. Sci. Eng. A* **276**, 108-116 (2000).
- [4] M. Gupta, L. Lu, M.O. Lai, K.H. Lee, Microstructure and mechanical properties of elemental and reinforced magnesium synthesized using flux-less liquid-phase process, *Mat. Res. Bull.* **34**, 1201-1214 (1999).
- [5] H.Y. Wang, Q.C. Jiang, X.L. Li, J.G. Wang, In situ synthesis of TiC/Mg composites in molten magnesium, *Scr. Mater.* **48**, 1349-1354 (2003).
- [6] A. Contreras, V.H. Lopez, E. Bedolla, Mg/Ti composites manufactured by pressure-less melt infiltration. *Scripta Materialia Scr. Mater.* **51**, 249-253 (2004).
- [7] H.Y. Wang, Q.C. Jiang, Y.Q. Zhao, F. Zhao, B.X. Ma, Y. Wang, Fabrication of TiB₂ and TiB₂-TiC

- particulates reinforced magnesium matrix composites, *Mat. Sci. Eng. A* **372**, 109-114 (2004).
- [8] S.F. Hassan, M. Gupta, Development of a novel magnesium-copper based composite with improved mechanical properties. *Mat. Res. Bull.* **37**, 377-389 (2002).
- [9] K. Mizuuchi, K. Inoue, K. Hamada, M. Sugiooka, M. Itami, M. Fukusumi, M. Kawahara, Processing of TiNi SMA fiber reinforced AZ31 Mg alloy matrix composite by pulsed current hot pressing. *Mat. Sci. Eng. A* **367**, 343-349 (2004).
- [10] P. Cortes, W.J. Cantwell, Fracture properties of a fiber-metal laminates based on magnesium alloy. *J. Mat. Sci.* **39**, 1081-1083 (2004).
- [11] W.L.E. Wong, M. Gupta, Using hybrid reinforcement methodology to enhance overall mechanical performance of pure magnesium. *J. Mat. Sci.* **40**, 2875-2882 (2005).
- [12] J.C. Rawers, H.E. Maupin, Metal-intermetallic composites formed by reaction-sintering metal foils. *J. Mat. Sci. Lett.* **12**, 637-639 (1993).
- [13] J.C. Rawers, J.S. Hansen, D.E. Alman, J.A. Hawk, Formation of sheet metal-intermetallic composites by self-propagation high-temperature reactions. *J. Mat. Sci. Lett.* **13**, 1357-1360 (1994).
- [14] D.E. Alman, J.C. Rawers, J.A. Hawk, Microstructural and failure characteristics of metal-intermetallic layered sheet composites. *Metall. Mater. Trans. A* **26**, 589-599 (1995).
- [15] D.J. Harach, K.S. Vecchio, Microstructure evolution in metal-intermetallic laminate (MIL) composites synthesized by reactive foil sintering in air. *Metall. Mater. Trans. A* **32**, 1493-1505 (2001).
- [16] A. Dziadoń, M. Konieczny, Structural transformations at the Cu-Ti interface during synthesis of copper-intermetallics layered composite. *Kovové Mater.*, 42-50, (2004).
- [17] A. Dziadoń, M. Konieczny, M. Gajewski, M. Iwan, Z. Rzączyńska, Microstructure evolution at the Cu-Ti interface during high temperature synthesis of copper-intermetallic phases layered composite, *Archives of Metallurgy and Materials* **54**, 2 (2009).
- [18] M. Konieczny, A. Dziadoń, Mechanical behaviour of multilayer metal-intermetallic laminate composite synthesised by reactive sintering of Cu/Ti foils, *Archives of Metallurgy and Materials* **52**, 4 (2007).
- [19] Phase Equilibria, Crystallographic and Thermodynamic Data of Binary Alloys, Landolt-Börnstein. New Series IV/5. Springer (1998).
- [20] G.W. Powell, J.D. Baun, Diffusion in the gold-indium system, *Trans. Metall. AIME* **230**, 694-699 (1964).
- [21] A.J. Hickl, R.W. Heckel, Kinetics of phase layer growth during aluminide coating of nickel, *Metall. Trans. A*, 431-440 (1975).
- [22] N. Tunc, R.W. Smith, Intermetallic compound layer growth at the interface of solid refractory metals molybdenum and niobium with molten aluminum, *Metall. Trans. A* **20**, 825-836 (1989).
- [23] P.L. Tu, Y.C. Chan, K.C. Hung, J.K.L. Lai, Growth kinetics of intermetallic compounds in chip scale package solder joint. *Scr. Mater.* **44**, 317-323 (2001).