

# A novel type of piezoactuated micropositioning system – simulation and experimental tests

Tomasz Bojko, Maciej Grzanka, Wojciech Rejmer

TB-Automation, Kraków

**Abstract:** A study of the novel type of piezoelectric actuated micropositioning system for pick-and-place type applications is reported. The objective of this work is to present mechanical design of micropositioning system, simulation test of main mechanical parts and to verify simulation test by real experiment. It also mentions the study of selected aspects of actuation system based on flexible joints and piezostack actuators, FEA simulations of flexible joints, connections and interactions between mechanical parts, and modular design of micropositioning system is also mentioned. Finally experimental results of individual mechanical modules are reported.

**Keywords:** micropositioner, piezoactuator, flexures, positioning system, FEA simulations

Most automated assembly lines require high efficiency pick-and-place operations. The higher is the precision of an operation task, the higher the precision of the manipulators required to complete the process is [1, 2]. Typical manipulators are designed having 2, 3 or maximum 4 axes. Main axes are usually translational, while additional axes are usually rotational. Typical manipulator for pick-and-place operation in assembly lines has 2 DOF (two degrees of freedom) and T-T (translational-translational) structure [3]. For a linear movement, both pneumatic or electric drives can be used, but for rotational movement electrical actuators are used more frequently. Typical pick-and-place manipulators have repeatability of 0.1 mm, and best existing solutions can achieve even 0.02 mm [4]. The higher is the precision of a part mounted, the more problems can be identified. Moreover, if assembly of parts requires force or failure detection, simple systems are not sufficient [5, 6].

## 1. Introduction

The main goal of the proposed micropositioning system is to build universal end-effector type device for cooperation with pick and place robot working on assembly line. Basic assumptions are listed below:

- Device should be mounted between arm of pick and place manipulator and effector,
- Device should have small dimensions and should not be very heavy,

- Main actuation system should be based on piezo stack actuators,
- Main linear transmission system should be based on flexure hinges,
- Device should be able to positioning of effector in X, Y plane,
- Device should have more than 0.2 mm X, Y range of movement,
- Resolution of X, Y range of movement should be better than 0.001 mm,
- Device should have possibility of measuring total force in Z direction (mounting direction),
- Maximum displacement in Z axes should not exceed 10 mm,
- System should have a possibility to measure displacement in each of three axes (X, Y and Z).

According to the above mentioned requirements, modular device with flexure hinges and piezoelectric actuators was designed.

## 2. Mechanical construction

The main objective during the designing process of mechanical construction was to complete all assumptions. Modular design was proposed for several reasons. The main reason was that it is easy to manufacture, but some other important reasons are: easy assembling, cost effective design, easy part replacement, easy adjustment process. Modular construction has two main levels. First level is responsible for clear separation of X, Y and Z module of movement, and second level is responsible for separation of compliant hinges from mounting and housing parts of micropositioner. General concept of one DOF translational module is shown in fig. 1.

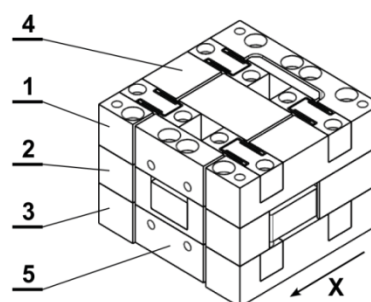
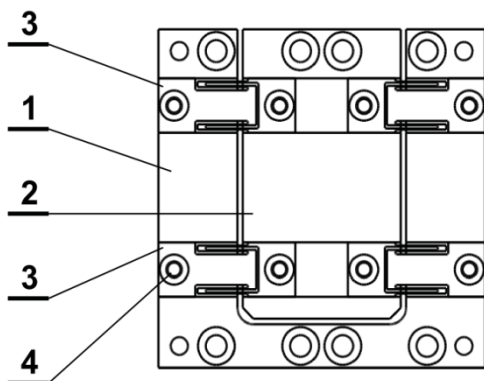

**Fig. 1.** A general concept of 1 DOF translational module  
**Rys. 1.** Moduł ruchu liniowego 1 DOF

One module consist of 3 independent layers (1, 2, 3). The layer in the middle (2) is responsible only for actuation. Inside this layer piezo stack actuator with mechanical amplifier is mounted. Two other layers top (1) and bottom (3) are functionally the same. These layers are responsible only for translational movement with 1 DOF between outer (4) and inner (5) parts of mechanism along presented X axis. Two translational layers mounted symmetrically with respect to actuated layer increase the overall stiffness of mechanism and provide more accurate movement in one particular direction [7, 8]. Two identical modules are connected in serial (one over one) but rotated at straight angle. It enables movement in X and Y direction independently. Movement in Z axis is realized in different way, and it will be explained below.

**2.1. Linear X, Y movement**

Linear movement is realized independently in each of 2 outer layer per one module. General concept of translational movement layer is shown on fig. 2 below. One layer consist of outer (1) and inner part (2). Outer part has C like shape, and inner part is moving inside this shape. These two parts are connected by 4 symmetrically distributed flexure hinges (3). Special shape of each flexure hinges causes linear movement only with one direction (1 DOF). Flexure hinges are made of titanium alloy, but the remaining parts are made of aluminum alloys. The elements are connected by screws (4).



**Fig. 2.** A general concept of 1 DOF translational layer with flexure joints

**Rys. 2.** Warstwa ruchu translacyjnego o jednym liniowym stopniu swobody 1 DOF z zawiasami elastycznymi

Proposed design has several advantages, such as: easy and low cost manufacturing, ability to easy replace elements and ability to easy change the configuration. The same layer is used in each module responsible for X and Y translational movement.

**2.2. Mechanical amplifier**

One of the assumptions of this project was to achieve moving distance more than 0.2 mm. Because the main actuation system is based on piezo stacks actuators, it

is difficult to achieve this range of movement without mechanical amplification. General concept of amplification mechanism is shown in fig. 3. Monolithic mechanical amplifier (1) has mounted piezostack actuator (2). Between piezostack actuator and mechanical amplifier distance plates (3) are used.

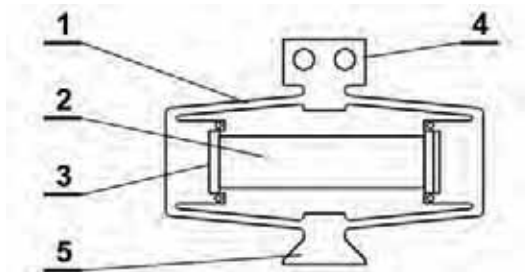

**Fig. 3.** Monolithic amplifier with mechanical slots (holes and dovetail) and piezoactuator mounted inside

**Rys. 3.** Monolithic amplifier with mechanical slots (holes and dovetail) and piezoactuator mounted inside

Amplifier (1) has special slots for mechanical connection to other parts. One side is mounted using screws (4) and the other side is mounted using dovetail connection (5). Amplifier is mounted to other parts by screw system. It allows for precision alignment of actuated parts as well as clearance reducing.

**2.3. Linear Z movement**

Linear movement in Z direction is generally different than X, Y translations. Main function of Z movement is to realize indirect force measurement for part assembly. In this case linear slide bearings, encoder and spring were proposed. The Z translation is realized by two slide bearings. Total stroke of this movement does not exceed 10 mm. General concept of this unit is shown in fig. 4 below.

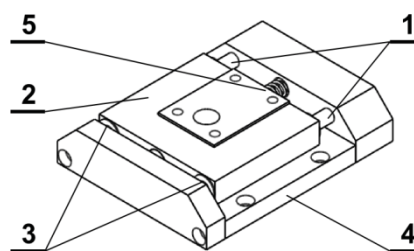

**Fig. 4.** General concept of linear Z movement system

**Rys. 4.** Układ ruchu liniowego w osi Z

The unit consists of 2 linear guides (1) and a slider (2). Slider is mounted on 4 slide bearings (3). Linear guides are mounted to fixed base (4). Modules responsible for precision movement in X, Y plane are mounted to moving slider using screws. It is worthy to note that Z movement is not actuated. Also it is not important that Z movement should be realized by precision flexure hinges, and it was the main reason for choosing linear slide guides. Linear movement is measured by magnetic encoder. Whole Z mechanism enables indirect force measurement system in Z axis. To

measure actual force, displacement between slider and base is measured. Measurement is made by linear magnetic encoder mounted between slider and the base. Between the same parts spring (5) with the known characteristic is mounted. Force is calculated as a proportional value to spring deflection.

## 2.4. 3D CAD model and real device

Full 3D assembly based on CAD model together with real assembled device is shown on fig. 5 in isometric view. Micropositioner consists of two modules responsible for positioning in X and Y direction respectively. Each module consists of 3 layers (one with piezo actuator and two with flexure hinges), as it was mentioned before. These two modules are mounted directly to moving slider.

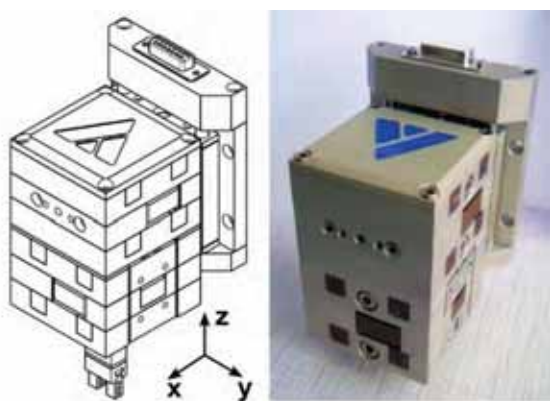

**Fig. 5.** CAD assembly of micropositioning system and mounted real device

**Rys. 5.** Model CAD mikropozycjonera i zmontowane urządzenie rzeczywiste

Micropositioner has serial X, Y, Z construction similar to cartesian manipulators. Main difference is that only two of them are actuated (X, Y) with high precision and third (Z) is used only for force measurement. Total overall dimensions are: 80×83×118 mm (W×D×H) and total weight without screws is ca. 1.2 kg.

## 3. FEM simulations

The most important thing during the designing process are simulation tests. Standard procedure of designing consist of several stages, as listed below:

1. General assumptions of CAD model
2. Detailed shape of particular parts
3. Initial FEM simulations
4. Result verifying
5. Changes in geometry
6. Finishing simulations
7. Final CAD model

Standard procedure assumes that steps from 4 to 6 should be repeated until the desired shape is achieved. Sometimes the optimization procedures can be applied. At the end of designing and simulation process a final CAD model is built. This model is ready for

manufacturing. All simulations tests are made using the Autodesk Simulation Multiphysics software.

### 3.1. Model of piezoelectric actuator

For actuation piezoelectric stack actuator Piezomechanik PSt 150/10×10/40 was chosen. Simulation tests of this piezoelectric stack were conducted using FEM method. Model of piezoelectric stack is build according to geometrical parameters delivered by manufacturer, and contains insulating and conductive layers as well as fastening parts at both ends. Material parameters including electrical and mechanical properties of piezoelectric material are compatible with the manufacturer technical data. Two simulations of piezostack actuator model were made: electrical and mechanical. In the first type of simulation, charge distribution in each layer was obtained after applying the voltage to the FEM model of piezostack. Results are shown in fig. 6.



**Fig. 6.** Charge distribution in piezostack actuator layers

**Rys. 6.** Rozkład ładunku w warstwach piezostacku

Following electrical simulation, mechanical simulation was conducted. Results of mechanical simulation show total displacement of piezostack as a function of applying voltage. Results are presented on the fig. 7 below.

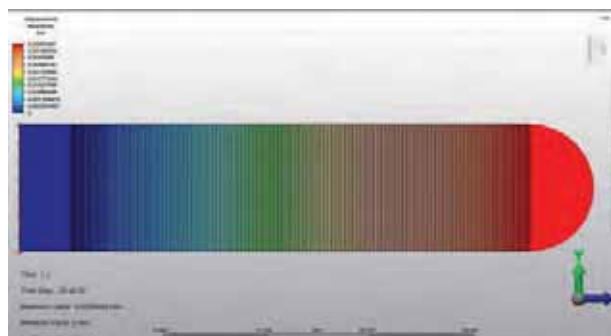

**Fig. 7.** Displacement as a function of applied voltage

**Rys. 7.** Przemieszczenie w funkcji przyłożonego napięcia

It is worthy to note that all simulation tests were carried out with unipolar voltage operation from range 0 V to 150 V. The picture presented above shows displacement distribution along working axis of piezoactuator after the maximum voltage has been applied. Maximum displacement from the simulation

test reaches 35  $\mu\text{m}$  and is close to the maximum real displacement provided in piezostack actuator datasheet. Comparison of simulation and experimental tests will be discussed below.

### 3.2. Model of linear hinges

Elastic hinges are responsible for linear motion in exactly one direction. These hinges are also responsible for holding all parts together. For this reason, the proper design of this part is very important. Simulation tests were conducted to show value of elasticity in one main direction and value of shiftiness in two other directions. Normal working direction for each module is along X or Y axis – depending on orientation of module. Movement in Z axis should be impossible for these modules. To speed up the simulation process a simplified model was used. Simplification relates to reducing the number of elastic hinges and modeling only half of each layer. One elastic hinge and simulation results are shown in fig. 8 below.

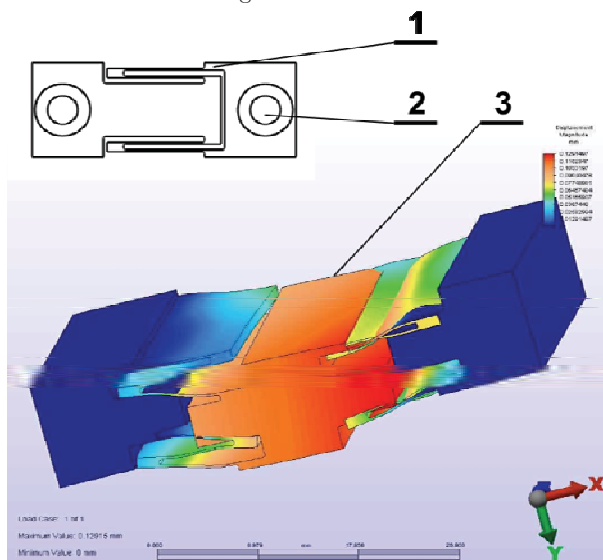

**Fig. 8.** Shape of 1 hinge and simulation results of a pair of flexure hinges

**Rys. 8.** Kształt pojedynczego zawiasu oraz wyniki symulacji dla pary elastycznych zawiasów złączowych

Each proposed hinge consists of 2 identical flexible blades in C shape (1). Part has 2 identical holes (2) for mounting in layer of positioner. Simulation was made as a connection of two symmetrically connected hinges. The results shows that the proposed shape of elastic hinges delivers very high stiffness ratio between working direction and two other main directions. It means that linear movement in one DOF should be very precise for each layer. The calculated results are shown in tab. 1 below:

**Tab. 1.** Simulation results for a pair of elastic hinges

**Tab. 1.** Wyniki symulacji dla pary elastycznych zawiasów

No	Direction:	Applied force [N]	Displacement mm
1	X	10N	0.0013
2	Y	10N	0.55
3	Z	10N	0.00025

### 3.3. Model of mechanical amplifier

Due to the fact that mechanical amplifier is directly responsible for stroke amplification, shape of this part is very important. After testing several shapes (each of them with small geometry differences) a proper shape was chosen. In each simulation maximum force and stack displacement was controlled. If force and displacement of stack did not correspond to real characteristics, the shape of amplifier was changed. The amplifier was tested with and without load. Simulation test was oriented for achieving maximum stroke of amplifier effector in range of ca. 0.2 mm after applying load. Load was modeled as an additional force, which represents the force of all flexure hinges existing in one actuated module. Simulation screen is presented in fig. 9 below.

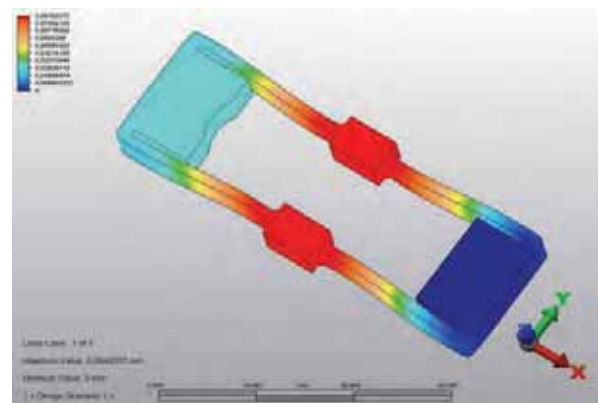

**Fig. 9.** Simulation screen of amplifier with load

**Rys. 9.** Symulacja wzmacniacza ruchu z obciążeniem

Simulation results show that the proposed shape has parameters that correspond to the assumptions. Table 2 below presents the results of the simulation:

**Tab. 2.** Simulation results

**Tab. 2.** Wyniki symulacji

Type	Piezo stack force [N]	Piezo stack displacement mm	Amplifier displ. mm
No load	200 [N]	0.039 mm	0.229 mm
load	800 [N]	0.038 mm	0.189 mm

## 4. Experimental tests

All experimental tests were made after part manufacturing and after assembling individual layers and modules. Experimental test was conducted using standard equipment: dynamometer and digital indicator. In each case, basic physical values such as displacement and force were measured. Three main components as: piezo stack actuator, mechanical amplifier and linear module were tested. Results are shown in chapters below.

### 4.1. Piezo stack actuator

Standard measurement of piezo stack actuator was performed. Displacement in function of applied voltage was determined. Measurement stand is showed in fig. 10.

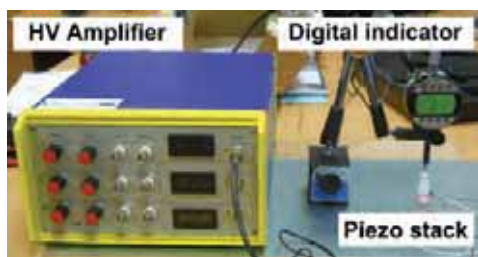

**Fig. 10.** Measurement arrangement for piezostack actuator  
**Rys. 10.** Stanowisko pomiarowe napędu piezoelektrycznego

Results of the measurement are presented on the graph below (fig. 11).

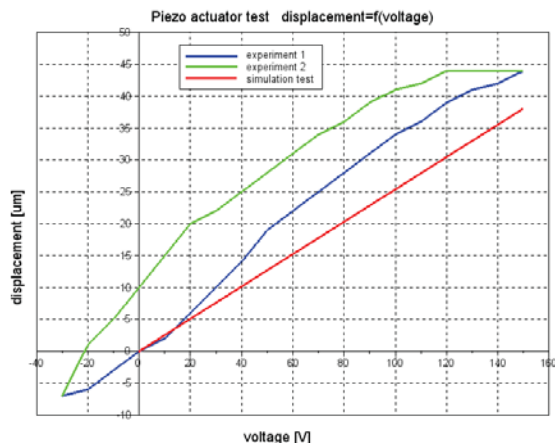
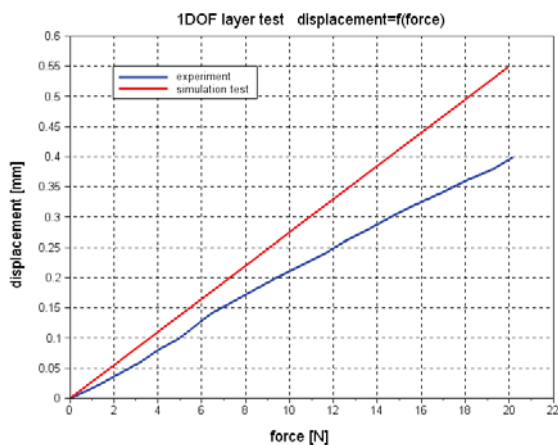

**Fig. 11.** Measurement results for piezostack actuator  
**Rys. 11.** Wyniki pomiaru przemieszczenia piezonapędu

The graph shows experimental test in comparison with simulations. As it is presented on the graph simulation test shows quite high similarity to experimental test. Main difference indicates that FEM simulation is linear, which means that hysteresis is omitted.

#### 4.2. 1DOF translational layer

Assembly of one layer of linear module, with 4 elastic hinges, was tested. Characteristic of displacement as a function of applied force was obtained. Results are shown in fig. 12 below.



**Fig. 12.** Experimental and simulation test of 1DOF linear layer with 4 elastic hinges

**Rys. 12.** Wyniki symulacji i eksperymentu dla warstwy ruchu liniowego z 4 elastycznymi zawiasami

Experimental test shows that simulation test corresponds to experimental one.

#### 4.3. Experimental test of mechanical amplifier and 1DOF linear module

Two different experimental tests with mechanical amplifier were conducted. The first test shows total displacement of amplifier effector in function of piezoactuator voltage but without any load. The second one demonstrates total displacement of individual 1DOF module as a function of voltage applied to piezostack actuator. This test was made after assembly of 1DOF module. Both Simulation and experimental results are shown on fig. 13 below.

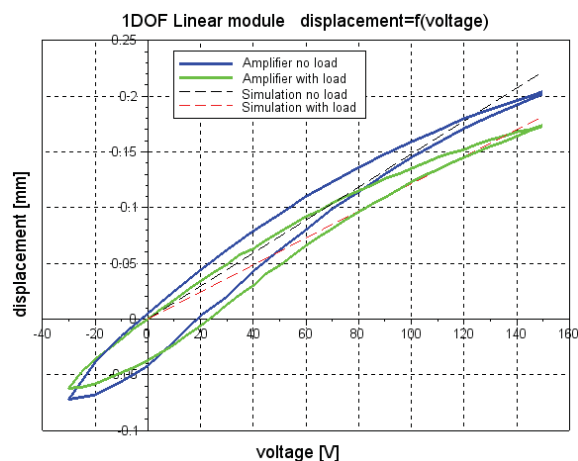

**Fig. 13.** Experimental and simulation test for mechanical amplifier and linear 1DOF module

**Rys. 13.** Wyniki symulacji i eksperymentu dla modułu liniowego 1DOF ze wzmacniaczem ruchu

Experimental test shows that the overall displacement of 1DOF translation module is similar to that resulted from the simulation tests. The difference between maximum displacement of free amplifier and the whole assembled module reaches 0.04 mm.

### 5. Conclusions

The paper demonstrated a general concept of micro positioning system. Mechanical construction, simulation and experimental tests have been reported.

Experimental tests proved that the proposed construction is good and corresponds to the established requirements. Minor discrepancies between simulation tests and experiment are caused by different tolerances of part manufacturing and assembling process. Another source of errors can be found in numerical and material inaccuracies. Similar situation exist when considering two different modules (X and Y). Between these modules difference of maximum stroke reaches 0.02 mm and is caused by small mechanical errors during assembly. Although FEM simulations are linear and do not include all physical parameters like e.g. hysteresis, it is a good way for error checking during designing process. Next step of research will cover the following areas: pick-and-place test of micropositioner together

with main manipulator and control system with force and position feedback.

The research work was supported by EU in project: "Industrial research in TB-Automation company" number 01 04 00 12 090 10 00.

Presented micropositioning mechanism is patented under UR RP number P400611.

## References

1. Prusak D., Uhl T., Petko M., *Mikrorobotyka Nowy kierunek rozwoju robotyki*, „Pomiary Automatyka Kontrola”, 2006, 05–08.
2. Fatikow S., Rembold U., *Microsystem Technology and Microrobotics*, Springer 1997.
3. Petko M., Karpel G., Prusak D., Martowicz A., *Kinematyka nowego typu manipulatora równoległego o trzech stopniach swobody*, „Pomiary Automatyka Kontrola”, 2004, 25–28.
4. [www.yamaha-motor.co.jp/global/industrial/robot/ypx/pdf/index/ypx-feature.pdf] – *Yamaha Pick and Place robots* (20.11.2012)
5. Rodriguez A., Bourne D., Mason M., Rossano G., Wang J.J., *Failure Detection in Assembly: Force Signature Analysis*, CASE, 2010, 210–215.
6. Prusak D., Uhl T., *Novel type of hybrid 3-DOF micromanipulator with piezoelectric actuators – mechanical construction and simulations*; Solid State Phenomena, 2009, 19–24.
7. Stuart T. Smith, *Flexures – Elements of elastic mechanisms*; G&B, 2003.
8. Lobontiu N., *Compliant Mechanisms*, CRC 2002. ■

## Nowy typ piezoelektrycznie napędzanego systemu mikropozycjonującego – badania symulacyjne i eksperymentalne

**Streszczenie:** W artykule zaprezentowano nowy typ piezoelektrycznie napędzanego urządzenia mikropozycjonującego do zastosowania w operacjach typu pobierz-odłóż (pick-and-place). Celem artykułu jest zaprezentowanie konstrukcji mechanicznej, przedstawienie badań symulacyjnych głównych elementów składowych, a także weryfikacja testów symulacyjnych przez eksperyment. Przedstawione zostały także wybrane aspekty układu napędowego, pracującego w oparciu o napęd piezoelektryczny i elastyczne przeguby złączowe typu flexures, a także wybrane aspekty związane z modelowaniem przy pomocy metody elementów skończonych MES, współpracy pomiędzy elementami mechanicznymi, oraz budowa modułowa urządzenia. W podsumowaniu przedstawiono wyniki testów eksperymentalnych wykonanego prototypu.

**Słowa kluczowe:** mikropozycjoner, napęd piezoelektryczny, elastyczne przeguby złączowe, system pozycjonowania, symulacje MES

### Tomasz Bojko, PhD

Owner of TB-Automation company. Engineer of mechatronics and designer of integrated systems. His work is focused on designing, programming testing, and integrating of medium and large scale mechatronic systems and automated robotics lines. He develops practical aspects of scientific knowledge.

e-mail: [biuro@tb-automation.com.pl](mailto:biuro@tb-automation.com.pl)



### Maciej Grzanka Eng

Engineer of automatics and electronics. Programmer and system integrator. His work is focused on designing and programming of automated mechatronic systems and components. He also concentrates on research and development of new ideas in the field of automatics and mechatronics.

e-mail: [biuro@tb-automation.com.pl](mailto:biuro@tb-automation.com.pl)



### Wojciech Rejmer, MSc

Engineer of automatics, PLC/PAC programmer, designer and integrator of industrial control systems. His work is focused on designing and programming of electric and electronic components of automatic and mechatronic systems. He also integrates control systems for automatic/robotic assembly lines.

e-mail: [biuro@tb-automation.com.pl](mailto:biuro@tb-automation.com.pl)

