

Foot design for a hexapod walking robot

Krzysztof Walas

Institute of Control and Information Engineering, Poznan University of Technology

Abstract: This article describes the process of development of the robotic foot for the six-legged walking robot Messor. In order to allow the robot to negotiate uneven surfaces and to walk on a compliant ground, the foot includes the sensing device which provides information on contact forces between the foot and the ground. At first, the foot with single-axis force measurement unit is described. Next, design of the tri-axial sensing device is shown. Knowledge gathered during development of the single-axis device was transferred to build a new foot with extended capabilities. In the article description of the manufactured real devices is given.

Keywords: walking robot, hexapod, foot, design

Mobile robots gather the most important information about the surrounding environment using the vision sensors. However, in the case of walking robots relying only on visual cues can be misleading. It may result, for instance, in the situation of the robot falling down due to wrong assessment of the type of the footholds. In the vision system the tactile data is missing. To obtain the required information, the appropriate foot with force sensing capability is required. Measurement of forces at the tip of the robot's leg enables good assessment of the type of terrain and in consequence adaptation of the type of gait to the changing characteristics of the foot-ground contact.

1. State of the art

1.1. Foot design

The design of the robot foot depends of the type of locomotion, that is, number on legs. In case of the humanoid robots the foot is large and allows the use of larger sensors. An example of the biped foot with 6-degrees-of-freedom (6-DOF) torque/force sensors was presented in [1–3], where author describes the design of the foot, which permits the robot to walk on uneven surface by measuring reaction forces and moments applied to the soles of the feet. This information allows the machine to keep balance on the rough ground. Other designs of the biped robot feet are aimed at mimicking the human foot. The article [4] describes the actuated 4-DOF foot with conducting polymer artificial muscles, which allow energy dissipation and storage. A different type of such a foot was presented in [5]. It resembles the human foot and the authors claim that the robot foot has the same functionality as the human one. The foot is equipped with seven independently drivable joints with magnetic rotary encoders to enable closed loop control of the foot configuration.



Fig. 1. A new design of the Messor robot foot equipped with the force measurement sensors

Rys. 1. Nowa konstrukcja stopy robota Messor wyposażona w czujniki siły

Another type of robots which are equipped with feet are quadrupeds. The type of foot differs from that used for humanoids, because the quadrupeds have smaller feet and the type of locomotion is different. An example of such a foot is given in [6]. The two toes of the foot are used for stable landing on uneven ground. The robot ALoF has the foot equipped with force sensors [7], which allows the robot to classify terrain using forced vibrations of the leg. The most recent design of the robot foot was presented in [8]. It is used on the robot MIT Cheetah and uses volumetric displacement of hyperelastic polymer for sensing the contact forces. Yet another type of the foot was presented in [9]. Its design allows the robot to walk on uneven ground, but additionally the robot is able to walk on the water surface. The list of the robot foot designs is not exhaustive, but gives an overview of the available devices. A foot for the six-legged robots attracted less attention. However, the

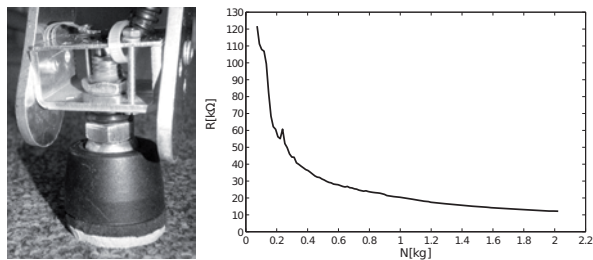

Fig. 2. The first model of the foot for the Messor robot. Measured non-linear resistance characteristics of the FSR sensor

Rys. 2. Pierwszy model stopy robota Messor. Zmierzone nieliniowe charakterystyki rezystancji czujnika FSR

foot used with the four-legged robots could be used on the hexapod machines.

1.2. Force Sensitive Resistors

Force Sensitive Resistors (FSR) are fabricated from the conductive polymer, which changes its resistance with applied pressure. The full description of the sensor and the integration guide are given in [10]. These sensors are used in a wide range of applications. For instance, they are used in the field of human walk assessment: [11] ankle rehabilitation, [12] knee brace locking timing, [13] plantar pressure measurement. Another possible application is the recognition of manipulative arm gestures [14]. Further applications of FSR concern the use of the sensors for: localization of objects by using sense of touch [15], measurement of pressure in user interfaces for mobile devices [16], and for the force and hit detection in tabletops (music instruments) [17]. Thorough tests of the FSR sensors were performed in different settings and were presented in several publications [18–21].

In this article the design process of the robotic foot for the six-legged robot Messor [22] is described. At first, the designs with the single-axis force measurement are shown. Then, the generalization of the obtained results to the 3-DOF sensor is described. The design process and the real device are described in details. At the end, concluding remarks together with planned future work are given.

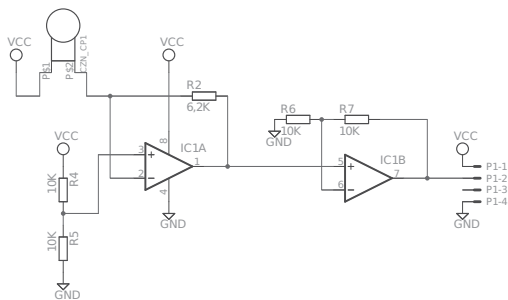

Fig. 3. Signal conditioning circuit of the FSR sensor. Current-to-voltage converter used to obtain linear output characteristics together with simple reversing circuit

Rys. 3. Układ kondycjonowania sygnałów czujnika FSR. Przetwornik prąd-napięcie użyty w celu osiągnięcia liniowego wyjścia przeskalowanego prostym wzmacniaczem odwracającym

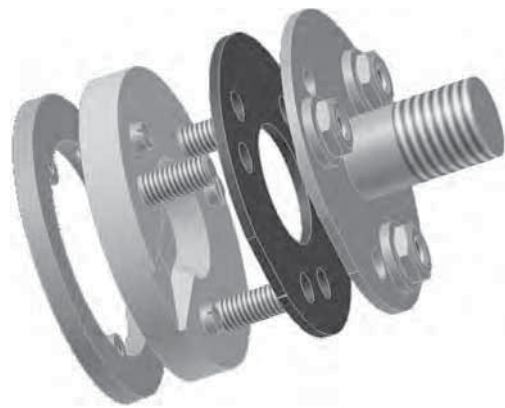

Fig. 4. Mechanical design of the second model of the foot. The pin is a truncated cone which guarantees repeatable shape of the contact area of the sensor fixed in the socket of similar shape as the pin

Rys. 4. Projekt mechaniczny drugiego modelu stopy. Trzpień w kształcie ściętego stożka pozwala na uzyskanie powtarzalnego kształtu powierzchni styku z czujnikiem umieszczonym w gnieździe, którego kształt jest podobny do kształtu trzpienia

2. The foot with single-axis force sensor

The first model of the robotic foot with the single-axis force sensor developed for the walking robot Messor was presented in [23]. This foot is shown in fig. 2. The foot has passive spherical joint and flat contact surface. This results in the disadvantage of foot hitting the uneven ground in unpredictable manner. In the presented design, the FSR sensor is a part of the voltage divider. As it was shown in the fig. 2, the FSR sensor has non-linear pressure-resistance characteristics, which is the reason for non-linear voltage output characteristics. Our experiments confirm the data from the catalog and from the measurements described in the articles mentioned in the previous section.

In order to overcome the above mentioned flaws of the system, a new design of the foot is proposed. The resistance characteristics and the coupled with them voltage output can be linearized using the appropriate signal conditioning circuit. To obtain this result, the current-to-voltage converter based on the operational amplifier was build. Additionally, a simple reversing circuit was designed to obtain appropriate levels of the signal. The complete circuit is shown in fig. 3.

For the sake of achieving reliability and repeatability of the measurements, the appropriate mechanical design is required as well. The earlier design suffers from the non-repeatable shape of the contact area. This influences heavily the obtained force measurements. As it was shown in fig. 4, the new mechanical design allows to obtain repeatable shape of the contact area. It was achieved by using the sensor-touching pin of the shape of a truncated cone. This provides now the self-centering property of the system.

The new foot together with the obtained characteristics of the force response is shown in fig. 5. However, for the better analysis of contact forces, knowledge of a complete vector is required and not only of its selected components.

3. The three-axis sensor

In order to obtain comprehensive information about the reaction force vector, a different foot design than presented previously was required. The complete vector can be obtained using at least three Force Resistive Sensors placed in the robot foot. In our approach two mechanical designs of the foot were proposed, which differ as to the number and layout of the sensors.

3.1. Design

The new foot design is based on the ball of diameter of 45 mm, made of the foam rubber. The rubber has moderate stiffness. The ball fits into the socket made of plastic Acrylonitrile Butadiene Styrene (ABS). In the upper part of the foot the cuboid-shaped fixing was designed. It allows to mount signal conditioning devices required to obtain linear output characteristics of the force measurements. The new robot foot with the printed circuit mounted on it is shown in fig. 6. The height of the foot is 73 mm.

In fig. 6 mechanical design of the third version of the foot model is presented. It contains five Force Resistive Sensors, with two of them placed at the intersections of positive and negative part of the x axis with the surface of the ball socket. Another two sensors are mounted at the intersections of the ball socket surface with positive and negative part of the y axis. One sensor is fixed at the intersection of the positive part of the z axis with the surface of the ball socket. The adopted local coordinate frame for the foot is shown in fig. 7. In the version (b) of the foot design, three force sensors equally spaced around the socket were used. The sensors are placed on the surface of the ball socket every 120° of the full angle around z axis (see fig. 7). Each of the sensors is tilted at 45° from the xy plane, which cuts the ball in half. The location of each sensor is shown in fig. 7, the vectors F_1, F_2, F_3 denote the forces acting on each FSR.

3.2. 3D printing

The designed shape of the sockets with sensors mounted inside is hard to obtain using the conventional milling machine. The volume of the material to be removed is very large. As an alternative, the socket may be manufactured in the casting process. However, this process is rather time-consuming and requires preparation of the mold, which has to be manufactured in the milling process. In order to obtain parts in a short period of time, the rapid prototyping techniques can be used. The sockets presented in this article were manufactured directly from the computer

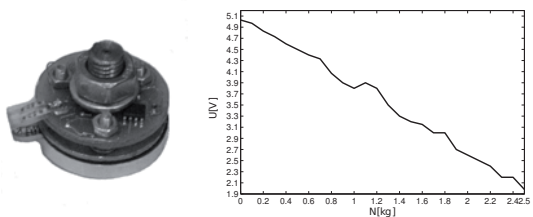

Fig. 5. The second model of the foot. Linear output of the force measurement system

Rys. 5. Drugi model stopy. Liniowa charakterystyka odpowiedzi układu pomiaru siły

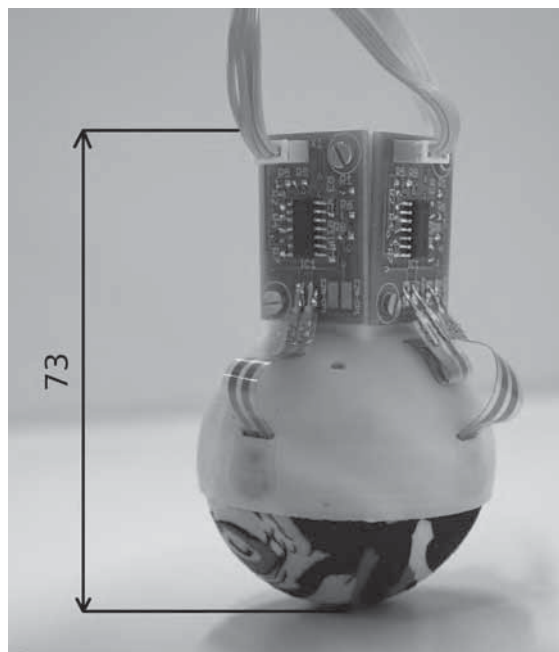

Fig. 6. The third model of the robot foot with force sensors and signal conditioning devices mounted on it

Rys. 6. Trzeci model stopy robota z zamontowanymi czujnikami i układami kondycjonowania sygnału

model using a 3D printer. The material used for the parts is the white ABS. Machine used in the fabrication process is the Stratasys Dimension 1200es. Thickness of a single layer is equal to 0.254 mm (0.01 inch). Wall of the sockets due to properties of the technological process has to be 2 mm thick. Moreover, to build such a part of a spherical shape, a supporting material has to be used to support upper layers of the part during the printing process. In the crust of the socket, thin extrusions were made for fixing the sensors.

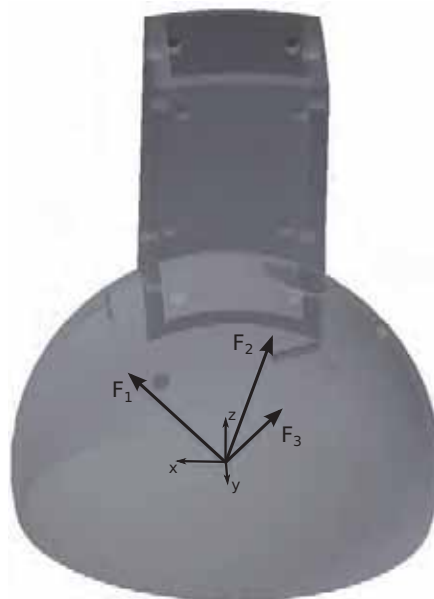

Fig. 7. Local coordinate frame for the foot. Forces F_1, F_2, F_3 point at each FSR

Rys. 7. Lokalny układ odniesienia dla stopy. Siły F_1, F_2, F_3 wskazują na każdy FSR

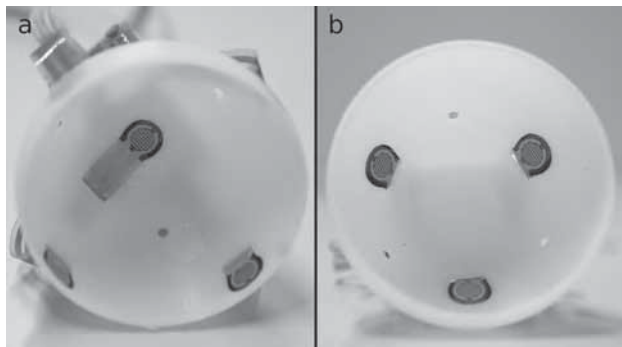

Fig. 8. Inner side of the ball socket of the foot. Version (a) with five force sensors, version (b) with three force sensors

Rys. 8. Wewnętrzna strona gniazda stopy. Wersja (a) z pięcioma czujnikami siły, wersja (b) z trzema czujnikami siły

The depth of the extrusions allows to obtain a smooth surface of the inner side of the socket in order to get a repeatable shape of the contact area between the ball and the force sensor. The small rectangular holes provide access to the mounting pads of the FSR. The inner side of the socket obtained in 3D printing is shown in fig. 8. The left figure shows the design with five sensors (version (a)), whereas the right figure – with three sensors (version (b)).

3.3. Electronics design

For the sake of achieving full functionality of the mechatronic system, the mechanical design has to be supported by the appropriate design of electronic circuits. In our case electronic schematic shown in fig. 3 was reused in the third model of the foot. The circuit was copied twice and it was possible to connect two sensors to the same printed circuit board (PCB). The foot with mounted PCB is shown in fig. 6. Tight limits on dimensions of the board resulted in the PCB of size 28 x 19.3 mm. A single chip with quad operational amplifiers was used on the PCB. This allowed to reduce the dimensions of the board. The output of the circuit is the voltage signal. This signal can be directly connected to the analogue-to-digital converter (ADC) of the robot controller. The other possibility is the connection to the ADC on the leg of the robot and transmission of the signal via digital interface (I2C, SPI) or using the ZigBee wireless technology (IEEE 802.15.4). The ZigBee modules, i.e. ATZB-24-A2, are equipped with ADC converters (3 input lines), so it is possible to connect the voltage signals directly to the ZigBee module and to send the values via wireless transfer protocol. These signals are easily accessible through AT commands from BitClouds software. Advantage of this solution is lack of wires connected to the foot, except for the power wires. What is more, the information on the contact forces can be acquired both on board of the robot and on a remote host.

4. Conclusions

The article describes the process of the walking robot foot design. The model of the foot with single-axis force sensor was shown. The improved version of the first design solves the problems of non-linearity of sensor readings as well as copes with the non-uniform force distribution on the sensor pad. Experience gained during the development

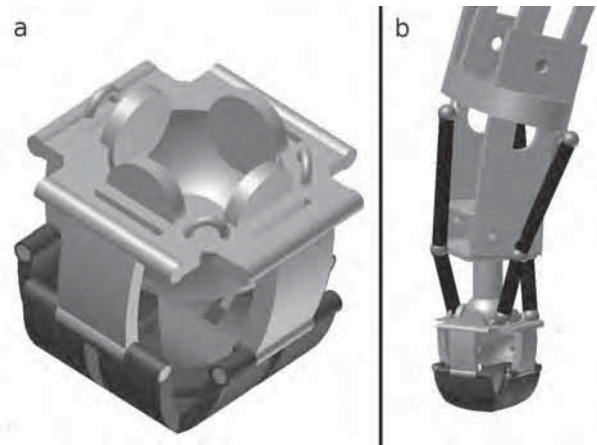

Fig. 9. The future design of the foot with 6-DOF force/torque measurement unit

Rys. 9. Projekt stopy z sześciosiowym czujnikiem siła/moment

of the foot with single-axis force sensor allowed to build the new foot with tri-axial force sensor. Two designs were proposed: one with five FSRs (Force Sensitive Resistors) and the other with three FSRs. The first solution gives direct information about the force along each axis. The second one requires performing some computations to obtain the elements of the force vector but involves only three sensors. It also sacrifices the angular range of forces, which this time can be measured by means of only three sensors tilted by 45° .

4.1. Future work

The presented foot requires extensive tests on the robot in different conditions to obtain durable and reliable measuring device. Development of the foot with the sensors which permit 6-DOF force/torque measurements is envisaged as a future work. Initial stages of the design have been already completed. The foot is suspended on permanent magnets (ball). The force and torque measurements are based on stretch sensors and the effect of bending of the bottom part of the foot which is compliant. The model of a future device like that is shown in fig. 9.

Acknowledgements

This work was supported by the National Science Centre of the Republic of Poland, Grant No. 2011/01/N/ST7/02070. I would like to thank my students who have helped me with the design of the improved 1-DOF foot Piotr Gendoła and Marek Czachorowski, as well as Bartłomiej Orczykowski for helping me with the design of the future 6-DOF foot.

References

1. Kim G.-S., Shin H.-J., Yoon J., *Development of 6-axis Force/Moment Sensor for Humanoid Robot's Foot*, [in:] IEEE Sensors, October, 2007, 217–220.
2. Kim G.-S., *Development of 6-axis force/moment sensor for a humanoid robot's foot*, "Science, Measurement Technology, IET", Vol. 2, No. 3, 2008, 122–133.
3. Kim G.-S., Yoon J., *Development of intelligent foot with six-axis force/moment sensors for humanoid robot*, [in:] IEEE International Conference on Robotics and Biomimetics (ROBIO), February, 2009, 939–944.

4. Secord T., Asada H., *A Humanoid Foot with Polypyrrole Conducting Polymer Artificial Muscles for Energy Dissipation and Storage*, [in:] IEEE International Conference on Robotics and Automation (ICRA), April, 2007, 2904–2909.
5. Davis S., Caldwell D., *The design of an anthropomorphic dexterous humanoid foot*, [in:] IEEE/RSJ International Conference on Intelligent Robots and Systems (IROS), October, 2010, 2200–2205.
6. Hong Y., Yi S., Ryu S., Lee C., *Design and experimental test of a new robot foot for a quadrupedal jointed-leg type walking robot*, [in:] 5th IEEE International Workshop on Robot and Human Communication, November, 1996, 317–322.
7. Hoepflinger M., Remy C., Hutter M., Spinello L., Siegwart R., *Haptic terrain classification for legged robots*, [in:] IEEE International Conference on Robotics and Automation (ICRA), May, 2010, 2828–2833.
8. Chuah M. Y. M., Estrada M., Kim S., *Composite Force Sensing Foot Utilizing Volumetric Displacement of a Hyperelastic Polymer*, [in:] IEEE/RSJ International Conference on Intelligent Robots and Systems (IROS), October, 2012, 1963–1969.
9. Park H. S., Sitti M., *Compliant footpad design analysis for a bio-inspired quadruped amphibious robot*, [in:] IEEE/RSJ International Conference on Intelligent Robots and Systems (IROS), October, 2009, 645–651.
10. *FSR Force Sensing Resistor Integration Guide and Evaluation Parts Catalog*, Interlink Electronics.
11. Evan D., *Design of Plantar Force Sensor for Ankle Rehabilitation Monitor*, EE 4BI6 Electrical Engineering Biomedical Capstones. Paper 42, 2010.
12. Moon S.-C., Lee C.-H., Lee S.-G., *A study of knee brace locking timing and walking pattern detected from an FSR and knee joint angle*, [in:] 11th International Conference on Control, Automation and Systems (ICCAS), October, 2011.
13. Rana N., *Application of Force Sensing Resistor (FSR) in Design of Pressure Scanning System for Plantar Pressure Measurement*, [in:] Second International Conference on Computer and Electrical Engineering, December, 2009, 678–685.
14. Ogris G., Kreil M., Lukowicz P., *Using FSR based muscle activity monitoring to recognize manipulative arm gestures*, [in:] 11th IEEE International Symposium on Wearable Computers, October, 2007, 45–48.
15. Desai A., Payandeh S., Vaisey J., *On the localization of objects using an FSR pressure pad transducer*, [in:] IEEE International Conference on Systems, Man, and Cybernetics, 1994, Humans, Information and Technology, October, 1994, 953–957.
16. Stewart C., Rohs M., Kratz S., Essl G., *Characteristics of pressure-based input for mobile devices*, [in:] Proceedings of the SIGCHI Conference on Human Factors in Computing Systems, ACM, New York, NY, USA, April, 2010, 801–810.
17. Bosi M., Jordà S., *Towards fast multi-point force and hit detection in tabletops using mechanically intercoupled Force Sensing Resistors*, [in:] NIME'12, Ann Arbor, Michigan, USA, May, 2012.
18. Zehr E., Stein R., Komiyama T., Kenwell Z., *Linearization of force sensing resistors (FSR's) for force measurement during gait*, [in:] Engineering in Medicine and Biology Society, 1995, IEEE 17th Annual Conference, September, 1995, 1571–1572.
19. Florez J., Velasquez A., *Calibration of force sensing resistors (FSR) for static and dynamic applications*, [in:] ANDESCON, 2010 IEEE, September, 2010, 1–6.
20. Lebosse C., Renaud P., Bayle B., de Mathelin M., *Modeling and Evaluation of Low-Cost Force Sensors*, "IEEE Transactions on Robotics", Vol. 27, No. 4, 2011, 815–822.
21. Krkljes D., Nagy L., Babkovic K., *Force-dependent contact area excitation of FSR force sensor utilizing dome-shaped rubber element*, [in:] 28th International Conference on Microelectronics (MIEL), May, 2012, 181–184.
22. Walas K., Belter D., *Messor – Versatile Walking Robot for Search and Rescue Missions*, "Journal of Automation, Mobile Robotics & Intelligent Systems", Vol. 5, No. 2, 2011, 28–34.
23. Walas K., Belter D., *Supporting locomotive functions of a six-legged walking robot*, "Int. J. Appl. Math. Comput. Sci.", Vol. 21, No. 2, 2011, 363–377. ■

Projekt stopy sześcionożnego robota kroczącego

Streszczenie: Niniejszy artykuł opisuje proces rozwoju stopy dla sześcionożnego robota kroczącego Messor. Stopa posiada wbudowane urządzenie do pomiaru sił kontaktu pomiędzy stopą a podłożem. Dane te są wymagane do kroczenia po nierównym i podatnym gruncie. W artykule pokazane zostało jednoosiowe urządzenie pomiarowe. Następnie opisany został czujnik trójosiowy bazujący na projekcji czujnika jednoosiowego. Artykuł prezentuje proces projektowania jak i opis rzeczywistego urządzenia.

Słowa kluczowe: robot kroczący, robot sześcionożny, stopa, projektowanie

Krzysztof Walas, PhD

Krzysztof Walas received the MSc and PhD degrees in control engineering and robotics from the Poznan University of Technology respectively in 2007 and 2012. He is currently an assistant professor at the Institute of Control and Information Engineering of the same university. His research interests include walking robots control, multisensor environment perception for navigation purposes and machine vision.

e-mail: krzysztof.walas@put.poznan.pl

