

Anti-collision system with radar obstacle detector

Jerzy Graffstein

Institute of Aviation, New Technology Centre Department, Warsaw

Abstract: In the article the construction of anti-collision system with radar obstacle detector is presented. Cooperation between individual sub-systems and devices is described in the paper. Functionality of subsequent sub-systems is discussed. Significant parameters characterising the system and its elements are presented.

Keywords: anti-collision system, collision avoidance system, avionics

1. Introduction

Growing flight safety requirements, defined either for manned or unmanned aircrafts, set the impulse for the Institute of Aviation to make an arrangement for the design of an in-flight anti-collision system. This task was realized within the frames of development project by the consortium created by three parties: the Institute of Aviation – the coordinator, Warsaw University of Technology and Microtech International Co. from Wrocław. The aim of the project was specified as the design and construction of an autonomous system capable to detect stationary and moving obstacles, and to produce estimates of the range to these obstacles and relative velocity of their motion. Implementation of the radar obstacle detector in the system makes it effective in poor visibility conditions e.g. during night flights.

Additionally, system's functionality was enriched by digital estimates of radio-altitude and vertical velocity (the rate of descent/climb), included in systems measurement capabilities for detecting the threat of crash into the ground. Software modules are prepared for ensuring future cooperation between anti-collision and flight control systems. Prepared project served as the basis for manufacturing of the first, test specimen of the system. It was used for ground tests and first in-flight tests.

2. The structure of anti-collision system

The general idea of AURA anti-collision system is presented on the scheme (fig. 1). The system is formed by the following elements:

- radar obstacle detector (RDP),
- digital radio-altimeter (CRW),
- AXMOD RDP micro-computer,
- AXMOD CRW micro-computer,
- central computer of anti-collision system,

- digital map of the terrain and data base of Obstacles,
- reference system AHRS.

The system is autonomous and based on three sources of information on obstacles: Radar Obstacle Detector, Digital Radio-Altitude and Digital Map of Terrain with Data Base of Obstacles. RDP detects stationary and moving obstacles and estimates their position and velocity (for moving ones). CRW estimates the height of flight above the terrain surface as well as the rate of this height. Original (primal) signals received from RDP and CRW are processed in AXMOD RDP and AXMOD CRW micro-computers to obtain the appropriate estimates of physical values. The Data Base of Obstacles contains the set of data (parameters) describing terrain stationary obstacles around the desired flight trajectory.

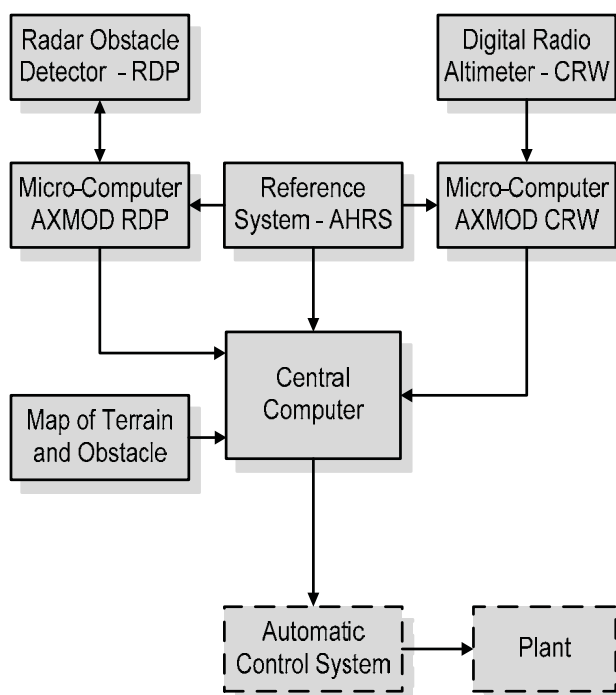

Fig. 1. The general block diagram of AURA anti-collision system
Rys. 1. Ogólny schemat blokowy antykolizyjnego systemu AURA

The software implemented in central computer is responsible for generation of the model of the shape of terrain around the flying object. This software is designed to create and persistently update the data base of obstacles including its appropriate spatial representation, computed on the basis of data received from RDP, as well as data representing the motion of flying object, obtained from AHRS and CRW. In every time step, when new data

sequence is acquired from the aforementioned sources, the risk of collision with detected obstacles is estimated. When the condition [1] is fulfilled the procedure is activated to find the most appropriate anti-collision manoeuvre. To execute this manoeuvre, an automatic flight control system is necessary, which is not a sub-system of anti-collision system.

3. Radar Obstacle Detector (RDP)

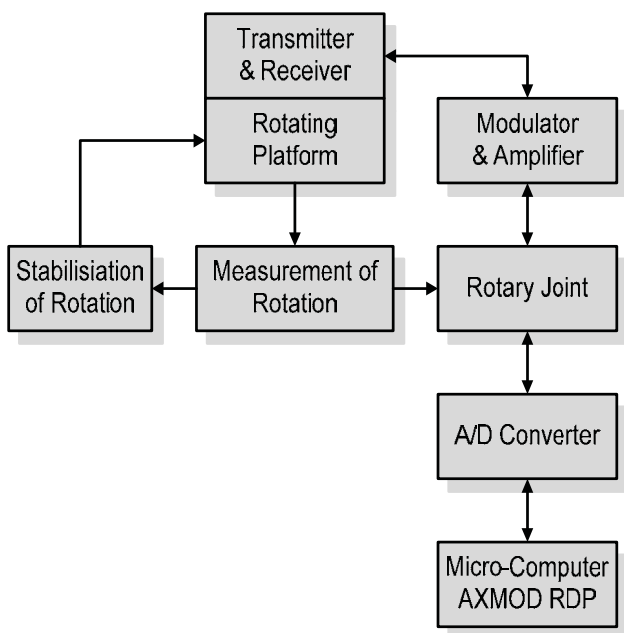

Fig. 2. The block scheme of Radar obstacle detector
Rys. 2. Schemat blokowy radarowego detektora przeszkód



Fig. 3. Radar obstacle detector (RDP)
Rys. 3. Radarowy detektor przeszkód (RDP)

The Radar Obstacle Detector is the basic device delivering the information about the current situation within an airspace area surrounding a flying object. It consists of

two IVS-148 type transmitters/receivers, 24 GHz modules, each one installed with transmitting and receiving antennas on one board of electronic hardware. Both modules are fastened to the upper side of stiff rotating platform at opposite sides (fig. 3). The signal is received from first and second modules interchangeably and then processed successively in modulator, washout filter and amplifier.



Fig. 4. Radar obstacle detector with cover
Rys. 4. Radarowy detektor przeszkód w obudowie

Transformed signal is transmitted from the rotating platform by multi-channel rotary joint (with slip rings) to 16-bit analog-to-digital converter, installed in lower, immovable part of RDP's housing.

Numerical processing of signal is realised in AXMOD-RDP computer. The Fast Fourier Transform (FFT) is computed there. Then, the obtained spectrum of the signal is analysed to decide the existence (detect) of hypothetical obstacles within the considered sector. When the obstacle is detected, two characteristic, crucial parameters are determined: the range between the obstacle and the object and the radial velocity of the obstacle towards the object. The RDP is capable to detect up to five obstacles in one sector with aforementioned parameters. Detection is accomplished in horizontal plane within the forefront of half-sphere, in the section defined by the angle of 156°.



Fig. 5. Radar obstacle detector – view of the bottom
Rys. 5. Radarowy detektor przeszkód – widok od spodu

This section represents 13 sectors, each one characterised by the angle of 12° . The angular rate of the platform's rotational motion is stabilised at constant level 18.85 rd/s. The hallotron detector is used for angular rate detection in stabilisation system (fig. 5). The range of detection is about 200 m. It depends on the size and shape of the obstacle, as well as the material the obstacle is made of. The housing of RDP (fig. 4) is of cylindrical shape with 170 mm diameter and 150 mm height. The overall mass with housing and micro-computer AXMOD-RDP inside does not exceed 1,9 kg.

4. Measuring System and Data Base

The AHRS and CRW are additional measuring modules assuring the correct operation of the system. The Attitude and Heading Reference System (AHRS) of type IG-500N (fig. 6), tendered by the SBG Systems company [2], is capable to estimate in wide range the attitude and linear position of the object flying in airspace. The device also delivers three components of linear velocity, angular rate, as well as components of acceleration. The maximum frequency of sampling used in AHRS is 100 Hz. The imbedded GPS receiver is used to compute the estimate of position in geographical coordinates (WGS84 standard) with 4 Hz frequency [3] and the absolute height (altitude) corrected by pressure sensors. Information, obtained from the AHRS, on attitude, position, and linear velocity of flying object is used to compute the estimates of absolute position and velocity of detected obstacle.



Fig. 6. The reference system AHRS of IG-500N type
Rys. 6. System odniesienia AHRA typu IG-500N

Taking as example measuring of constant attitude angles, the accuracy is not worse than $\pm 1^\circ$. Obtained accuracy of measurements makes it possible to classify this system as one in medium class of similar devices. Small dimensions, $36 \times 49 \times 22$ mm, and small mass, 46 g (without GPS antenna), define the advantage of discussed device.



Fig. 7. Digital Radio Altimeter (CRW)
Rys. 7. Cyfrowy Radio – Wysokościomierz (CRW)

The digital radio-altimeter (figs. 7, 8), designed and manufactured in the Institute of Aviation is capable to measure the flight height over the surface of the Earth within the range from 0 m up to 300 m with 20 Hz frequency. The obtained accuracy is ± 1 m within the range from 0 m up to 20 m and not worse than about $\pm 5\%$ over this range. The vertical velocity is estimated within the range ± 1 m/s up to ± 30 m/s. CRW, when compared with the AHRS, is a more trustworthy source of information about the relative flight height. This is the reason that the role of CRW is, in case of the possibility to use a data base of terrain height. The correlation of the relative flight height and tendencies of its variation can make it capable to forecast the threat of the crash of the flying object into the ground.



Fig. 8. Elements of Digital Radio Altimeter
Rys. 8. Elementy Cyfrowego Radio-Wysokościomierza

The apparatus, with antennas (Fig.7) and AXMOD-CRW micro-computer, is encapsulated within the housing of dimensions $204 \times 91 \times 55$ mm, and it's overall mass is less than 1,1 kg.

The data base of the shape of terrain is built of text files (tendered by Geosystem company) containing information on height of terrain with objects on the ground included. Data was prepared in orthogonal reference system with 20×20 m resolution.

5. Computing hardware and software

AXMOD RDP and AXMOD CRW micro-computers (fig. 9) are hardware-identical computing platforms, composed of a specialised FPGA module and the unit based on Cortex processor with Linux operating system implemented. The signal from RDP is received in a synchronised regime by the FPGA module and preliminary processing, including Fast Fourier Transform (FFT), is realised therein. Further analysis of the signal is performed by Cortex processor module to obtained data about ranges and velocities of obstacles detected within respective sectors of fanning beam. Software implemented in AXMOD CRW micro-computer is operating in analogous regime. In this case, the difference consists in averaging results of the analysis of received signal. In order to improve the accuracy of height measurement and rate of climb/descent estimation, the CRW sub-system adjusts adaptively to the most fitted factor of electromagnetic waves reflection,

characteristic for the terrain over which the flight is realised.



Fig. 9. Micro Computer AXMOD with A/D converter

Rys. 9. Mikrokomputer AXMOD z przetwornikiem A/C

In AXMOD RDP and AXMOD CRW micro-computers software operates as independent, and synchronisation based on connection of measurements obtained from several units is realised in central computer. The model describing the airspace and terrain with detected obstacles allocated is also created therein. Software used for creating this model makes use of data obtained from aforementioned measuring units as well as from the database to accomplish necessary transformations between appropriate reference systems.

6. Conclusions

After suitable adaptation (mainly in software area), the system is capable to be used in Unmanned Airspace Vehicles (UAV), either automatically or remotely controlled, as well as in objects piloted by human crew on board.

The problem of functionality partition between anti-collision and flight control systems have to be solved for the first class of objects. Another problem is the procedure of flight control transfer between anti-collision subsystem and module realising the flight along prescribed trajectory. The design of graphical interface for the pilot is necessary for the second class of objects

Presented system can be applied in objects moving not faster than 50 m/s, due to the range of RDP. More precise estimate of the limit for this velocity can be determined in case of known manoeuvrability of the object.

The system was tested either on ground or in flight of A600 'Talon' helicopter with two-persons crew (fig. 10). Results obtained show the necessity for further investigations aimed at possible modifications and more accurate

checking of assumed parameters. Improvements introduced in algorithms of data processing are expected to improve robustness to disturbances and efficiency of obstacle detection.



Fig. 10. Installation of anti-collision system on A600 "Talon" helicopter

Rys. 10. Instalacja systemu antykolizyjnego na śmigłowcu A600 „Talon”

Acknowledgement

This work was supported from funds for science in the years 2010 to 2012 as a development project no. OR00011711.

References

1. Graffstein J., *Elementy procesu wykrycia zagrożenia kolizją i automatycznie sterowany manewr awaryjny*, "Pomiary Automatyka Robotyka" 2/2012, Warszawa, 383–387.
2. *IG-500N GPS aided AHRS User Manual*, SBG Systems, 2009.
3. Jankowski S., Szymański Z., Szczyrek J., *Reconstruction of environment model by using radar vector field histograms*, "Photonics Applications in Astronomy, Communications, Industry, and High-Energy Physics Experiments", [in:] Proc. of SPIE, Vol. 8454, No. 845422, 2012.

Antykolizyjny system wykorzystujący radarowy detektor przeszkód

Streszczenie: W pracy przedstawiono opis budowy systemu antykolizyjnego wykorzystującego radarowy detektor przeszkód. Opisano sposób współdziałania poszczególnych urządzeń. Przedstawiono sposób i zakres wykonywanych funkcji przez poszczególne urządzenia systemu. Zamieszczono istotne parametry techniczne charakteryzujące system i jego elementy.

Słowa kluczowe: system antykolizyjny, system wykrywania przeszkód, awionika

Jerzy Graffstein, PhD

Assistant professor in New Technology Centre Department of the Institute of Aviation (Instytut Lotnictwa) Warsaw, Poland. Scientific interest focused on modeling of flying object's motion, automatic flight control along the prescribed trajectory and autonomous anti-collision systems in avionic application.

e-mail: jgraff@ilot.edu.pl

